

HCPL2531SDV Datasheet

www.digi-electronics.com



<https://www.DiGi-Electronics.com>

DiGi Electronics Part Number	HCPL2531SDV-DG
Manufacturer	onsemi
Manufacturer Product Number	HCPL2531SDV
Description	OPTOISO 2.5KV 2CH TRANS 8SMD
Detailed Description	Optoisolator Transistor Output 2500Vrms 2 Channel 8-SMD

This model HCPL2531SDV is available at DiGi Electronics.

DiGi Electronics offers a global database of semiconductor and electronic component datasheets.

We welcome your inquiries regarding pricing, lead time, or other product-related questions.

 [Request a Quote](#)

 [Datasheet Search](#)



Tel: +00 852-30501935

RFQ Email: Info@DiGi-Electronics.com

DiGi is a global authorized distributor of electronic components.

Purchase and inquiry

Manufacturer Product Number:

HCPL2531SDV

Series:

-

Number of Channels:

2

Current Transfer Ratio (Min):

19% @ 16mA

Turn On / Turn Off Time (Typ):

450ns, 300ns

Input Type:

DC

Voltage - Output (Max):

20V

Voltage - Forward (Vf) (Typ):

1.45V

Vce Saturation (Max):

-

Mounting Type:

Surface Mount

Supplier Device Package:

8-SMD

Manufacturer:

onsemi

Product Status:

Obsolete

Voltage - Isolation:

2500Vrms

Current Transfer Ratio (Max):

50% @ 16mA

Rise / Fall Time (Typ):

-

Output Type:

Transistor

Current - Output / Channel:

8mA

Current - DC Forward (If) (Max):

25 mA

Operating Temperature:

-55°C ~ 100°C

Package / Case:

8-SMD, Gull Wing

Base Product Number:

HCPL2531

Environmental & Export classification

RoHS Status:

ROHS3 Compliant

REACH Status:

REACH Unaffected

HTSUS:

8541.49.8000

Moisture Sensitivity Level (MSL):

1 (Unlimited)

ECCN:

EAR99

ON Semiconductor

Is Now

onsemiTM

**To learn more about onsemiTM, please visit our website at
www.onsemi.com**

onsemi and **onsemi** and other names, marks, and brands are registered and/or common law trademarks of Semiconductor Components Industries, LLC dba "**onsemi**" or its affiliates and/or subsidiaries in the United States and/or other countries. **onsemi** owns the rights to a number of patents, trademarks, copyrights, trade secrets, and other intellectual property. A listing of **onsemi** product/patent coverage may be accessed at www.onsemi.com/site/pdf/Patent-Marking.pdf. **onsemi** reserves the right to make changes at any time to any products or information herein, without notice. The information herein is provided "as-is" and **onsemi** makes no warranty, representation or guarantee regarding the accuracy of the information, product features, availability, functionality, or suitability of its products for any particular purpose, nor does **onsemi** assume any liability arising out of the application or use of any product or circuit, and specifically disclaims any and all liability, including without limitation special, consequential or incidental damages. Buyer is responsible for its products and applications using **onsemi** products, including compliance with all laws, regulations and safety requirements or standards, regardless of any support or applications information provided by **onsemi**. "Typical" parameters which may be provided in **onsemi** data sheets and/or specifications can and do vary in different applications and actual performance may vary over time. All operating parameters, including "Typicals" must be validated for each customer application by customer's technical experts. **onsemi** does not convey any license under any of its intellectual property rights nor the rights of others. **onsemi** products are not designed, intended, or authorized for use as a critical component in life support systems or any FDA Class 3 medical devices or medical devices with a same or similar classification in a foreign jurisdiction or any devices intended for implantation in the human body. Should Buyer purchase or use **onsemi** products for any such unintended or unauthorized application, Buyer shall indemnify and hold **onsemi** and its officers, employees, subsidiaries, affiliates, and distributors harmless against all claims, costs, damages, and expenses, and reasonable attorney fees arising out of, directly or indirectly, any claim of personal injury or death associated with such unintended or unauthorized use, even if such claim alleges that **onsemi** was negligent regarding the design or manufacture of the part. **onsemi** is an Equal Opportunity/Affirmative Action Employer. This literature is subject to all applicable copyright laws and is not for resale in any manner. Other names and brands may be claimed as the property of others.



Is Now Part of



ON Semiconductor®

To learn more about ON Semiconductor, please visit our website at
www.onsemi.com

Please note: As part of the Fairchild Semiconductor integration, some of the Fairchild orderable part numbers will need to change in order to meet ON Semiconductor's system requirements. Since the ON Semiconductor product management systems do not have the ability to manage part nomenclature that utilizes an underscore (_), the underscore (_) in the Fairchild part numbers will be changed to a dash (-). This document may contain device numbers with an underscore (_). Please check the ON Semiconductor website to verify the updated device numbers. The most current and up-to-date ordering information can be found at www.onsemi.com. Please email any questions regarding the system integration to Fairchild_questions@onsemi.com.

ON Semiconductor and the ON Semiconductor logo are trademarks of Semiconductor Components Industries, LLC dba ON Semiconductor or its subsidiaries in the United States and/or other countries. ON Semiconductor owns the rights to a number of patents, trademarks, copyrights, trade secrets, and other intellectual property. A listing of ON Semiconductor's product/patent coverage may be accessed at www.onsemi.com/site/pdf/Patent-Marking.pdf. ON Semiconductor reserves the right to make changes without further notice to any products herein. ON Semiconductor makes no warranty, representation or guarantee regarding the suitability of its products for any particular purpose, nor does ON Semiconductor assume any liability arising out of the application or use of any product or circuit, and specifically disclaims any and all liability, including without limitation special, consequential or incidental damages. Buyer is responsible for its products and applications using ON Semiconductor products, including compliance with all laws, regulations and safety requirements or standards, regardless of any support or applications information provided by ON Semiconductor. "Typical" parameters which may be provided in ON Semiconductor data sheets and/or specifications can and do vary in different applications and actual performance may vary over time. All operating parameters, including "Typicals" must be validated for each customer application by customer's technical experts. ON Semiconductor does not convey any license under its patent rights nor the rights of others. ON Semiconductor products are not designed, intended, or authorized for use as a critical component in life support systems or any FDA Class 3 medical devices or medical devices with a same or similar classification in a foreign jurisdiction or any devices intended for implantation in the human body. Should Buyer purchase or use ON Semiconductor products for any such unintended or unauthorized application, Buyer shall indemnify and hold ON Semiconductor and its officers, employees, subsidiaries, affiliates, and distributors harmless against all claims, costs, damages, and expenses, and reasonable attorney fees arising out of, directly or indirectly, any claim of personal injury or death associated with such unintended or unauthorized use, even if such claim alleges that ON Semiconductor was negligent regarding the design or manufacture of the part. ON Semiconductor is an Equal Opportunity/Affirmative Action Employer. This literature is subject to all applicable copyright laws and is not for resale in any manner.



August 2008

Single-Channel: 6N135, 6N136, HCPL2503, HCPL4502 Dual-Channel: HCPL2530, HCPL2531 High Speed Transistor Optocouplers

Features

- High speed –1 MBit/s
- Superior CMR – 10kV/μs
- Dual-Channel HCPL2530/HCPL2531
- Double working voltage – 480V RMS
- CTR guaranteed 0–70°C
- U.L. recognized (File # E90700)

Applications

- Line receivers
- Pulse transformer replacement
- Output interface to CMOS-LSTTL-TTL
- Wide bandwidth analog coupling

Description

The HCPL4502, HCPL2503, 6N135, 6N136, HCPL2530 and HCPL2531 optocouplers consist of an AlGaAs LED optically coupled to a high speed photodetector transistor.

A separate connection for the bias of the photodiode improves the speed by several orders of magnitude over conventional phototransistor optocouplers by reducing the base-collector capacitance of the input transistor.

An internal noise shield provides superior common mode rejection of 10kV/μs. An improved package allows superior insulation permitting a 480V working voltage compared to industry standard of 220V.

Schematics

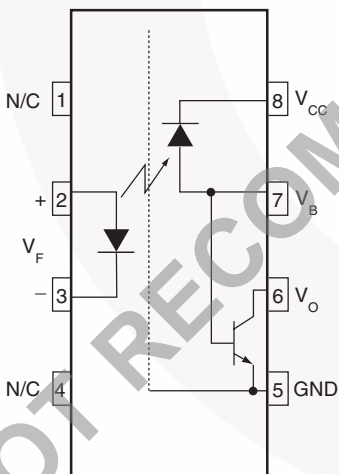

6N135, 6N136, HCPL2503, HCPL4502

Pin 7 is not connected in Part Number HCPL4502

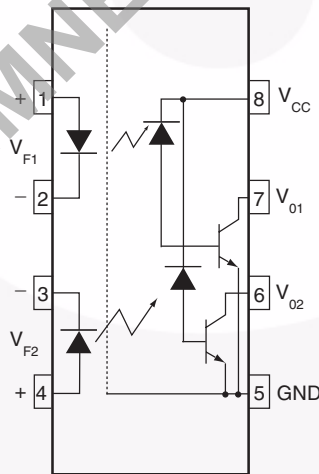

HCPL2530/HCPL2531

Package Outlines

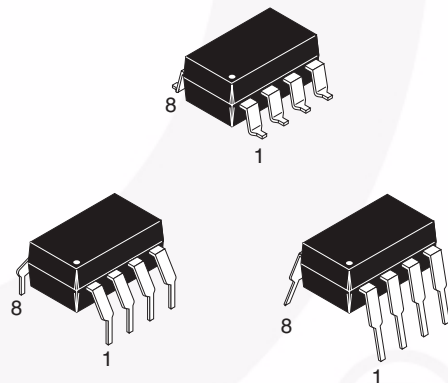

Single-Channel: 6N135, 6N136, HCPL2503, HCPL4502 Dual-Channel: HCPL2530, HCPL2531 — High Speed Transistor Optocouplers

Absolute Maximum Ratings ($T_A = 25^\circ\text{C}$ unless otherwise specified)

Stresses exceeding the absolute maximum ratings may damage the device. The device may not function or be operable above the recommended operating conditions and stressing the parts to these levels is not recommended. In addition, extended exposure to stresses above the recommended operating conditions may affect device reliability. The absolute maximum ratings are stress ratings only.

Symbol	Parameter	Condition	Value	Units
T_{STG}	Storage Temperature		-55 to +125	$^\circ\text{C}$
T_{OPR}	Operating Temperature		-55 to +100	$^\circ\text{C}$
T_{SOL}	Lead Solder Temperature		260 for 10 sec	$^\circ\text{C}$
EMITTER				
I_F (avg)	DC/Average Forward Input Current Each Channel ⁽¹⁾		25	mA
I_F (pk)	Peak Forward Input Current Each Channel ⁽²⁾	50% duty cycle, 1ms P.W.	50	mA
I_F (trans)	Peak Transient Input Current Each Channel	$\leq 1\mu\text{s}$ P.W., 300pps	1.0	A
V_R	Reverse Input Voltage Each Channel		5	V
P_D	Input Power Dissipation Each Channel	6N135/6N136 and HCPL2503/4502	100	mW
		HCPL-2530/253 ⁽³⁾	45	
DETECTOR				
I_O (avg)	Average Output Current Each Channel		8	mA
I_O (pk)	Peak Output Current Each Channel		16	mA
V_{EBR}	Emitter-Base Reverse Voltage	6N135, 6N136 and HCPL2503 only	5	V
V_{CC}	Supply Voltage		-0.5 to 30	V
V_O	Output Voltage		-0.5 to 20	V
I_B	Base Current	6N135, 6N136 and HCPL2503 only	5	mA
PD	Output Power Dissipation Each Channel	6N135, 6N136, HCPL2503, HCPL4502 ⁽⁴⁾	100	mW
		HCPL2530, HCPL2531	35	mW

Notes:

1. Derate linearly above 70°C free-air temperature at a rate of $0.8\text{mA}/^\circ\text{C}$.
2. Derate linearly above 70°C free-air temperature at a rate of $1.6\text{mA}/^\circ\text{C}$.
3. Derate linearly above 70°C free-air temperature at a rate of $0.9\text{ mW}/^\circ\text{C}$.
4. Derate linearly above 70°C free-air temperature at a rate of $2.0\text{ mW}/^\circ\text{C}$.

Electrical Characteristics ($T_A = 0$ to 70°C Unless otherwise specified)

Individual Component Characteristics

Symbol	Parameter	Test Conditions	Device	Min.	Typ.*	Max.	Unit
EMITTER							
V_F	Input Forward Voltage	$I_F = 16\text{mA}$, $T_A = 25^\circ\text{C}$			1.45	1.7	V
		$I_F = 16\text{mA}$				1.8	
B_{VR}	Input Reverse Breakdown Voltage	$I_R = 10\ \mu\text{A}$		5.0			V
$\Delta V_F/\Delta T_A$	Temperature Coefficient of Forward Voltage	$I_F = 16\text{mA}$			-1.6		mV/ $^\circ\text{C}$
DETECTOR							
I_{OH}	Logic High Output Current	$I_F = 0\text{mA}$, $V_O = V_{CC} = 5.5\text{V}$, $T_A = 25^\circ\text{C}$	All		0.001	0.5	μA
		$I_F = 0\text{mA}$, $V_O = V_{CC} = 15\text{V}$, $T_A = 25^\circ\text{C}$	6N135 6N136 HCPL4502 HCPL2503		0.005	1	
		$I_F = 0\text{mA}$, $V_O = V_{CC} = 15\text{V}$	All			50	
I_{CCL}	Logic Low Supply Current	$I_F = 16\text{mA}$, $V_O = \text{Open}$, $V_{CC} = 15\text{V}$	6N135 6N136 HCPL4502 HCPL2503		120	200	μA
		$I_{F1} = I_{F2} = 16\text{mA}$, $V_O = \text{Open}$, $V_{CC} = 15\text{V}$	HCPL2530 HCPL2531		200	400	
I_{CCH}	Logic High Supply Current	$I_F = 0\text{mA}$, $V_O = \text{Open}$, $V_{CC} = 15\text{V}$, $T_A = 25^\circ\text{C}$	6N135 6N136 HCPL4502 HCPL2503			1	μA
		$I_F = 0\text{mA}$, $V_O = \text{Open}$, $V_{CC} = 15\text{V}$	6N135 6N136 HCPL4502 HCPL2503			2	
		$I_F = 0\text{mA}$, $V_O = \text{Open}$, $V_{CC} = 15\text{V}$	HCPL2530 HCPL2531		0.02	4	

*All Typical at $T_A = 25^\circ\text{C}$

Electrical Characteristics (Continued) ($T_A = 0$ to 70°C unless otherwise specified)

Transfer Characteristics

Symbol	Parameter	Test Conditions	Device	Min.	Typ.*	Max.	Unit		
COUPLED									
CTR	Current Transfer Ratio ⁽⁵⁾	$I_F = 16\text{mA}, V_O = 0.4\text{V}, V_{CC} = 4.5\text{V}, T_A = 25^\circ\text{C}$	6N135 HCPL2530	7	18	50	%		
			6N136 HCPL4502 HCPL2531	19	27	50	%		
			HCPL2503	12	27		%		
		$I_F = 16\text{mA}, V_{CC} = 4.5\text{V}$	$V_{OL} = 0.4\text{V}$	6N135	5	21			%
			$V_{OL} = 0.5\text{V}$	HCPL2530					
			$V_{OL} = 0.4\text{V}$	6N136 HCPL4502	15	30		%	
			$V_{OL} = 0.5\text{V}$	HCPL2531					
$V_{OL} = 0.4\text{V}$	HCPL2503	9	30		%				
V_{OL}	Logic LOW Output Voltage	$I_F = 16\text{mA}, I_O = 1.1\text{mA}, V_{CC} = 4.5\text{V}, T_A = 25^\circ\text{C}$	6N135		0.18	0.4	V		
			HCPL2530		0.18	0.5			
		$I_F = 16\text{mA}, I_O = 3\text{mA}, V_{CC} = 4.5\text{V}, T_A = 25^\circ\text{C}$	6N136 HCPL2503		0.25	0.4			
		HCPL2531		0.25	0.5				
		$I_F = 16\text{mA}, I_O = 0.8\text{mA}, V_{CC} = 4.5\text{V}$	6N135 HCPL2530			0.5			
$I_F = 16\text{mA}, I_O = 2.4\text{mA}, V_{CC} = 4.5\text{V}$	HCPL4502 HCPL2531			0.5					

*All Typicals at $T_A = 25^\circ\text{C}$

Note:

- Current Transfer Ratio is defined as a ratio of output collector current, I_O , to the forward LED input current, I_F , times 100%.

NOT RECOMMENDED FOR NEW DESIGN

Electrical Characteristics (Continued) ($T_A = 0$ to 70°C unless otherwise specified)

Switching Characteristics ($V_{CC} = 5\text{V}$)

Symbol	Parameter	Test Conditions	Device	Min.	Typ.*	Max.	Unit
T_{PHL}	Propagation Delay Time to Logic LOW	$T_A = 25^\circ\text{C}$, $R_L = 4.1\text{k}\Omega$, $I_F = 16\text{mA}^{(6)}$ (Fig. 7)	6N135 HCPL2530		0.45	1.5	μs
		$R_L = 1.9\text{k}\Omega$, $I_F = 16\text{mA}$, $T_A = 25^\circ\text{C}^{(7)}$ (Fig. 7)	6N136 HCPL4502 HCPL2503 HCPL2531		0.45	0.8	μs
		$R_L = 4.1\text{k}\Omega$, $I_F = 16\text{mA}^{(6)}$ (Fig. 7)	6N135 HCPL2530			2.0	μs
		$R_L = 1.9\text{k}\Omega$, $I_F = 16\text{mA}^{(7)}$ (Fig. 7)	6N136 HCPL4502 HCPL2503 HCPL2531			1.0	μs
T_{PLH}	Propagation Delay Time to Logic HIGH	$T_A = 25^\circ\text{C}$, ($R_L = 4.1\text{k}\Omega$, $I_F = 16\text{mA}^{(6)}$) (Fig. 7)	6N135 HCPL2530		0.5	1.5	μs
		$R_L = 1.9\text{k}\Omega$, $I_F = 16\text{mA}^{(7)}$ (Fig. 7) $T_A = 25^\circ\text{C}$	6N136 HCPL4502 HCPL2503 HCPL2531		0.3	0.8	μs
		$R_L = 4.1\text{k}\Omega$, $I_F = 16\text{mA}^{(6)}$ (Fig. 7)	6N135 HCPL2530			2.0	μs
		$R_L = 1.9\text{k}\Omega$, $I_F = 16\text{mA}^{(7)}$ (Fig. 7)	6N136 HCPL4502 HCPL2503 HCPL2531			1.0	μs
ICM_{HI}	Common Mode Transient Immunity at Logic High	$I_F = 0\text{mA}$, $V_{CM} = 10\text{V}_{P-P}$, $R_L = 4.1\text{k}\Omega$, $T_A = 25^\circ\text{C}^{(8)}$ (Fig. 8)	6N135 HCPL2530		10,000		$\text{V}/\mu\text{s}$
		$I_F = 0\text{mA}$, $V_{CM} = 10\text{V}_{P-P}$, $R_L = 1.9\text{k}\Omega$, $T_A = 25^\circ\text{C}^{(8)}$ (Fig. 8)	6N136 HCPL4502 HCPL2503 HCPL2531		10,000		$\text{V}/\mu\text{s}$
ICM_{LI}	Common Mode Transient Immunity at Logic Low	$I_F = 16\text{mA}$, $V_{CM} = 10\text{V}_{P-P}$, $R_L = 4.1\text{k}\Omega$, $T_A = 25^\circ\text{C}^{(8)}$ (Fig. 8)	6N135 HCPL2530		10,000		$\text{V}/\mu\text{s}$
		$I_F = 16\text{mA}$, $V_{CM} = 10\text{V}_{P-P}$, $R_L = 1.9\text{k}\Omega^{(8)}$ (Fig. 8)	6N136 HCPL4502 HCPL2503 HCPL2531		10,000		$\text{V}/\mu\text{s}$

** All Typical at $T_A = 25^\circ\text{C}$

Notes:

6. The $4.1\text{k}\Omega$ load represents 1 LSTTL unit load of 0.36mA and $6.1\text{k}\Omega$ pull-up resistor.
7. The $1.9\text{k}\Omega$ load represents 1 TTL unit load of 1.6mA and $5.6\text{k}\Omega$ pull-up resistor.
8. Common mode transient immunity in logic high level is the maximum tolerable (positive) dV_{cm}/dt on the leading edge of the common mode pulse signal V_{CM} , to assure that the output will remain in a logic high state (i.e., $V_O > 2.0\text{V}$). Common mode transient immunity in logic low level is the maximum tolerable (negative) dV_{cm}/dt on the trailing edge of the common mode pulse signal, V_{CM} , to assure that the output will remain in a logic low state (i.e., $V_O < 0.8\text{V}$).

Electrical Characteristics (Continued) ($T_A = 0$ to 70°C unless otherwise specified)

Isolation Characteristics ($T_A = 0$ to 70°C Unless otherwise specified)

Symbol	Characteristics	Test Conditions	Min	Typ**	Max	Unit
I_{I-O}	Input-Output Insulation Leakage Current	Relative humidity = 45%, $T_A = 25^\circ\text{C}$, $t = 5\text{s}$, $V_{I-O} = 3000\text{VDC}^{(9)}$			1.0	μA
V_{ISO}	Withstand Insulation Test Voltage	$RH \leq 50\%$, $T_A = 25^\circ\text{C}$, $I_{I-O} \leq 2\mu\text{A}$, $t = 1\text{min.}^{(9)}$	2500			V_{RMS}
R_{I-O}	Resistance (Input to Output)	$V_{I-O} = 500\text{VDC}^{(9)}$		10^{12}		Ω
C_{I-O}	Capacitance (Input to Output)	$f = 1\text{MHz}^{(9)}$		0.6		pF
HFE	DC Current Gain	$I_O = 3\text{mA}$, $V_O = 5\text{V}^{(9)}$		150		
I_{I-I}	Input-Input Insulation Leakage Current	$RH \leq 45\%$, $V_{I-I} = 500\text{VDC}^{(10)}$ $t = 5\text{s}$, (HCPL2530/2531 only)		0.005		μA
R_{I-I}	Input-Input Resistance	$V_{I-I} = 500\text{VDC}^{(10)}$ (HCPL2530/2531 only)		10^{11}		Ω
C_{I-I}	Input-Input Capacitance	$f = 1\text{MHz}^{(10)}$ (HCPL2530/2531 only)		0.03		pF

Notes:

9. Device is considered a two terminal device: Pins 1, 2, 3 and 4 are shorted together and Pins 5, 6, 7 and 8 are shorted together.
10. Measured between pins 1 and 2 shorted together, and pins 3 and 4 shorted together.



Typical Performance Curves

Fig. 1 Normalized CTR vs. Forward Current

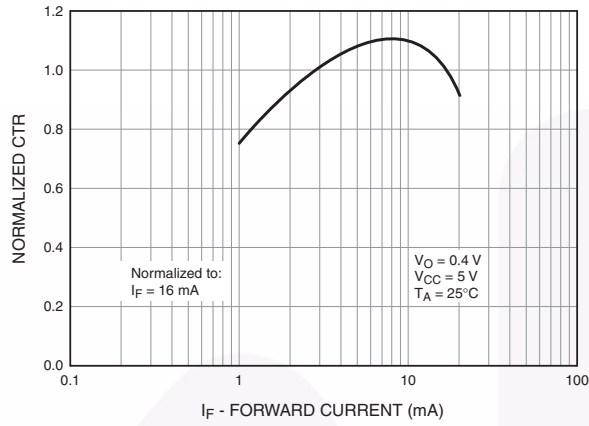

Fig. 2 Normalized CTR vs. Temperature

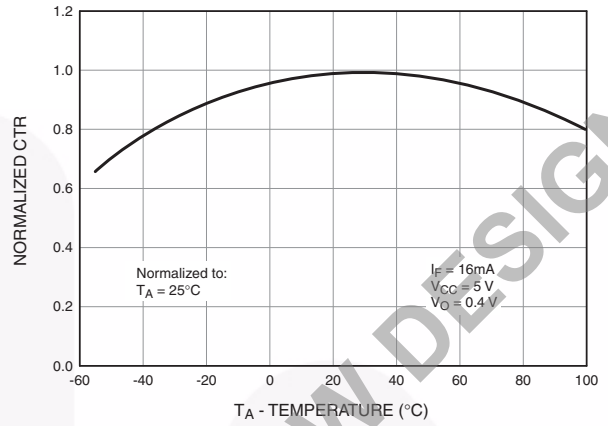

Fig. 3 Output Current vs. Output Voltage

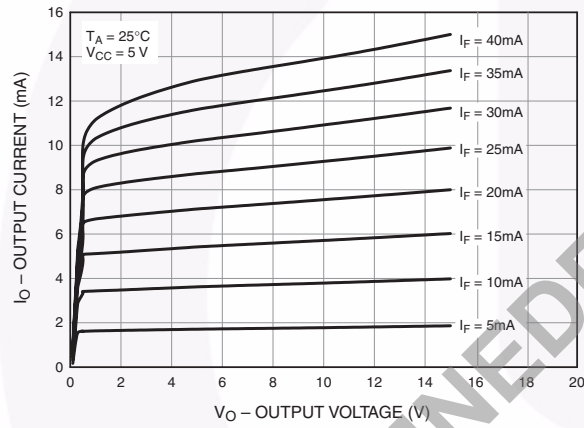

Fig. 4 Logic High Output Current vs. Temperature

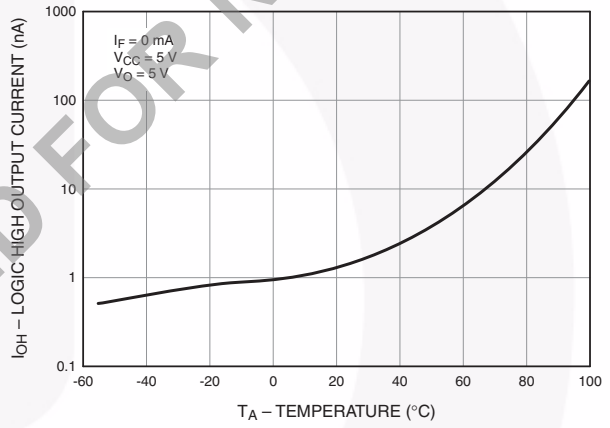

Fig. 5 Propagation Delay vs. Temperature

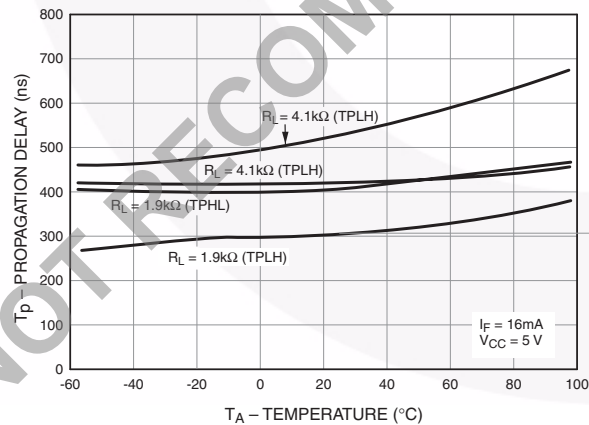
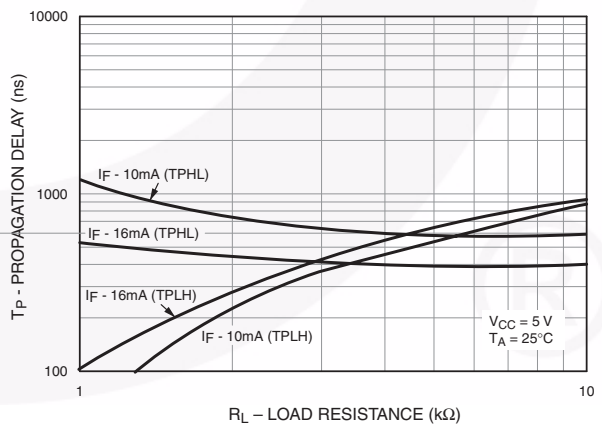
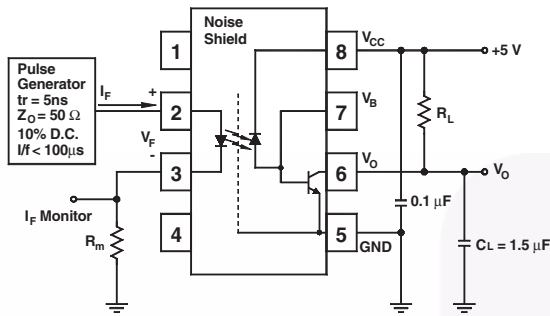

Fig. 6 Propagation Delay vs. Load Resistance



Single-Channel: 6N135, 6N136, HCPL2503, HCPL4502 Dual-Channel: HCPL2530, HCPL2531 — High Speed Transistor Optocouplers

Test Circuits



Test Circuit for 6N135, 6N136, HCPL-2503 and HCPL-4502

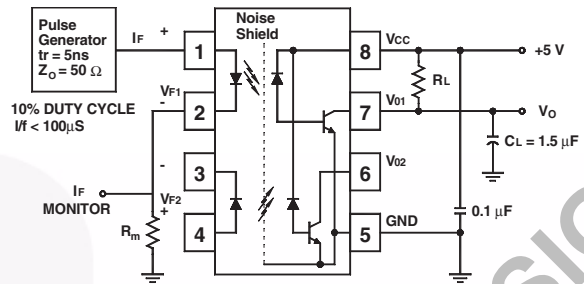

Test Circuit for HCPL-2530 and HCPL-2531

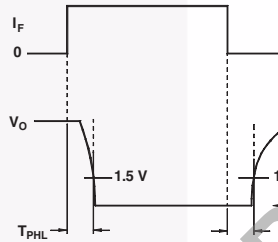
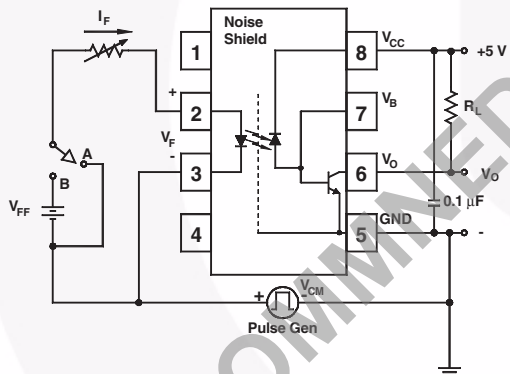
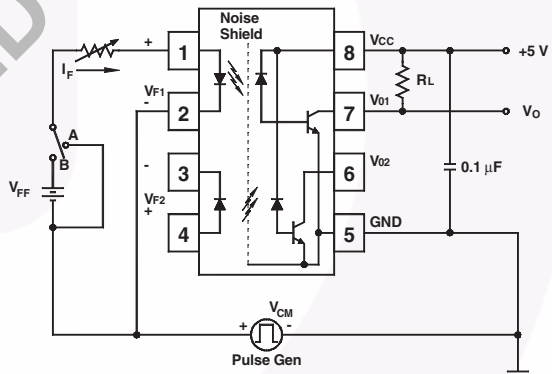

Fig. 7 Switching Time Test Circuit



Test Circuit for 6N135, 6N136, HCPL-2503 and HCPL-4502



Test Circuit for HCPL-2530 and HCPL-2531

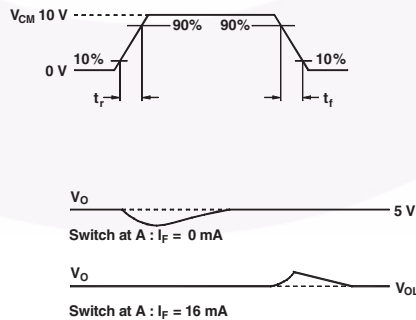

Fig. 8 Common Mode Immunity Test Circuit

Single-Channel: 6N135, 6N136, HCPL2503, HCPL4502 Dual-Channel: HCPL2530, HCPL2531 — High Speed Transistor Optocouplers

Ordering Information

Option	Example Part Number	Description
S	6N135S	Surface Mount Lead Bend
SD	6N135SD	Surface Mount; Tape and reel
W	6N135W	0.4" Lead Spacing
V	6N135V	VDE0884
WV	6N135WV	VDE0884; 0.4" lead spacing
SV	6N135SV	VDE0884; surface mount
SDV	6N135SDV	VDE0884; surface mount; tape and reel

Marking Information

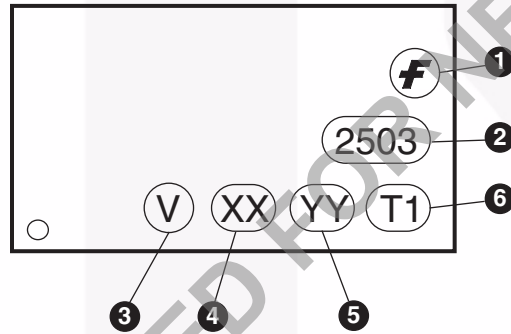

Definitions	
1	Fairchild logo
2	Device number
3	VDE mark (Note: Only appears on parts ordered with VDE option – See order entry table)
4	Two digit year code, e.g., '03'
5	Two digit work week ranging from '01' to '53'
6	Assembly package code

Tape Specifications

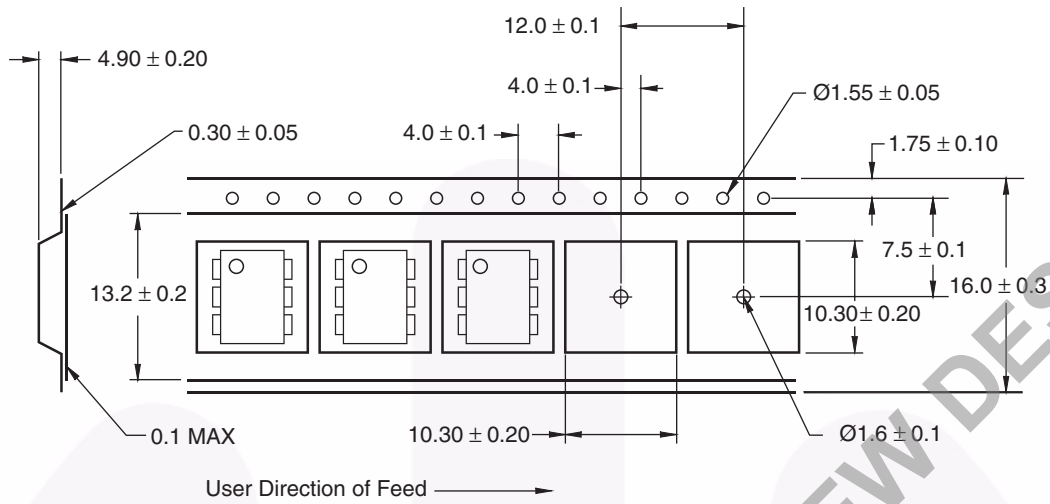

Reflow Profile

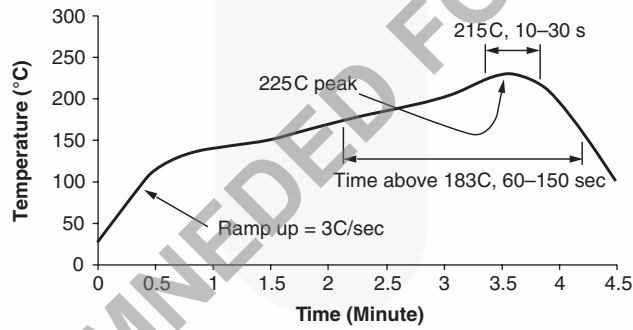

- Peak reflow temperature: 225C (package surface temperature)
- Time of temperature higher than 183C for 60–150 seconds
- One time soldering reflow is recommended

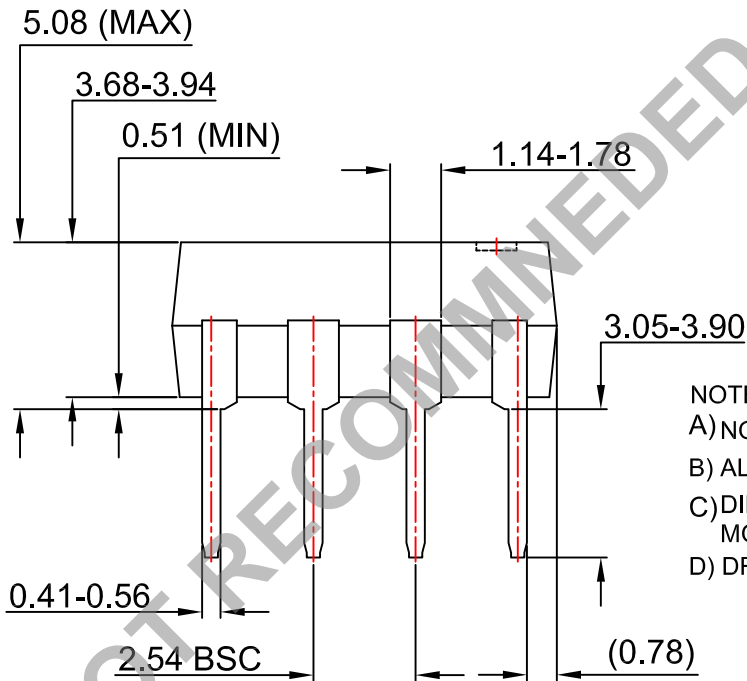
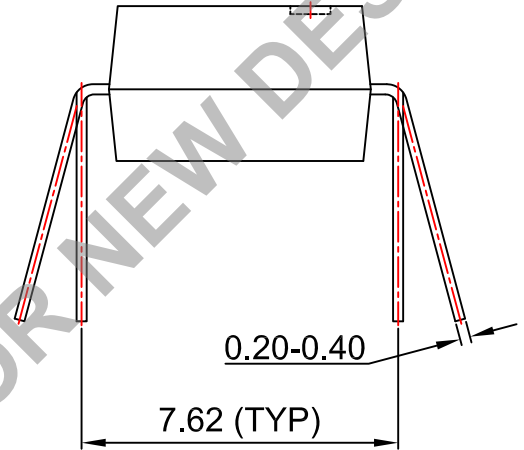
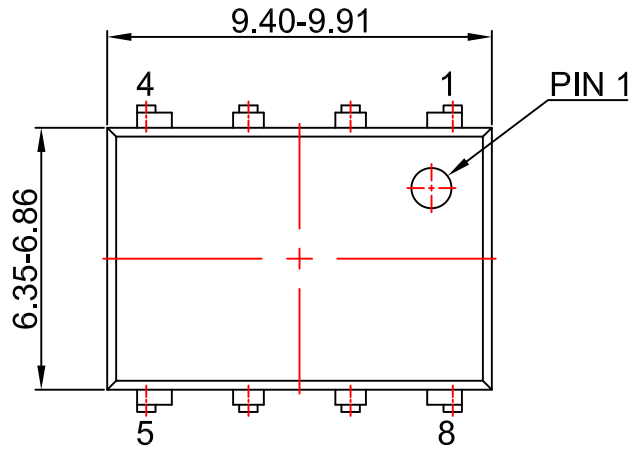

NOTES:

- A) NO STANDARD APPLIES TO THIS PACKAGE
- B) ALL DIMENSIONS ARE IN MILLIMETERS.
- C) DIMENSIONS ARE EXCLUSIVE OF BURRS, MOLD FLASH, AND TIE BAR EXTRUSION
- D) DRAWING FILENAME AND REVISION: MKT-N08GREV7



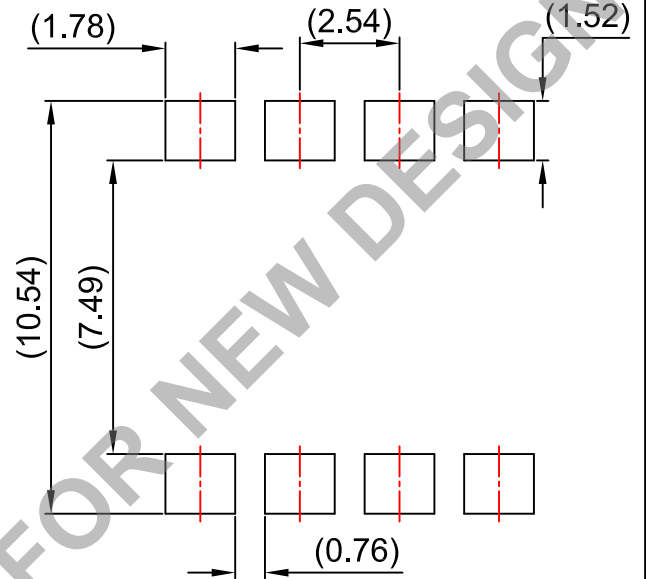
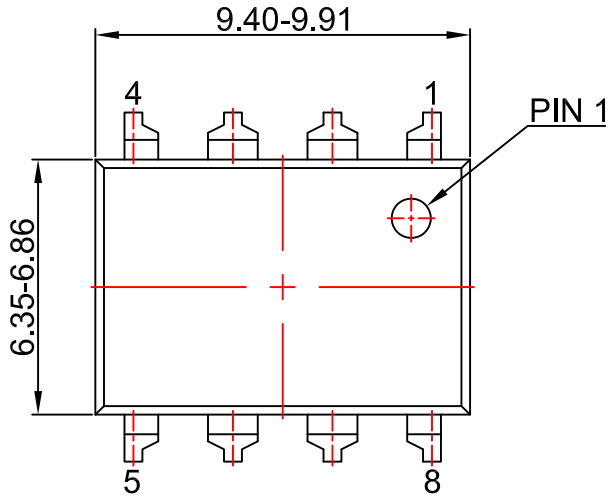

LAND PATTERN RECOMMENDATION

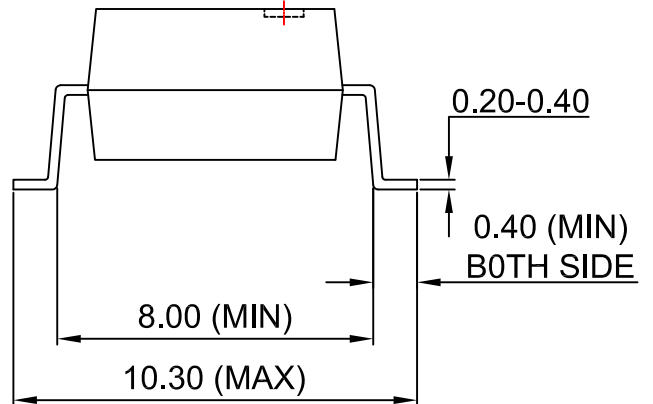
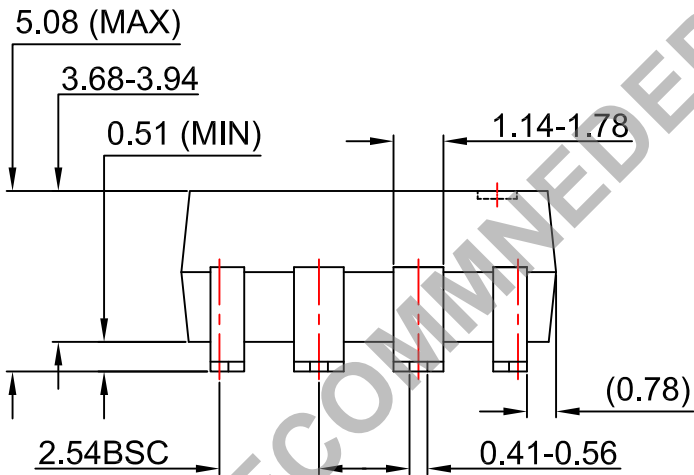

NOTES:

- A) NO STANDARD APPLIES TO THIS PACKAGE
- B) ALL DIMENSIONS ARE IN MILLIMETERS.
- C) DIMENSIONS ARE EXCLUSIVE OF BURRS, MOLD FLASH, AND TIE BAR EXTRUSION
- D) DRAWING FILENAME AND REVISION: MKT-N08Hrev7.



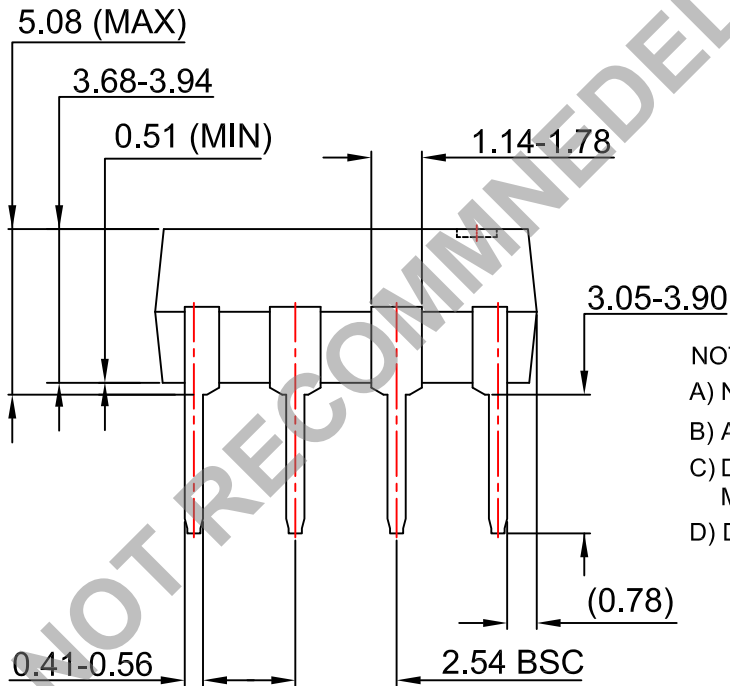
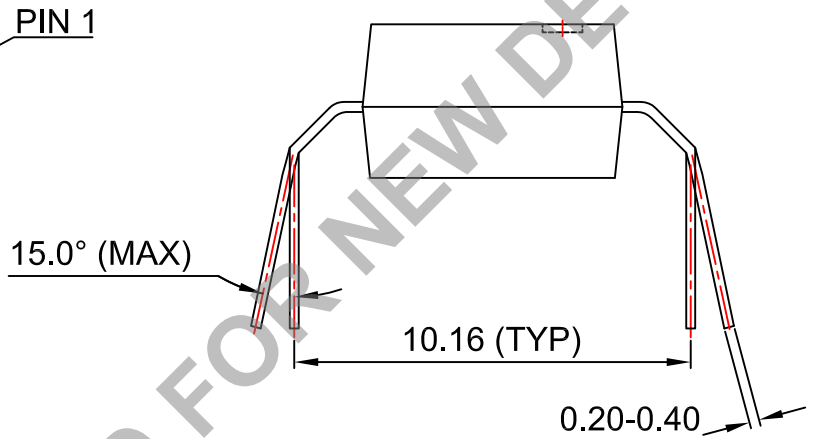
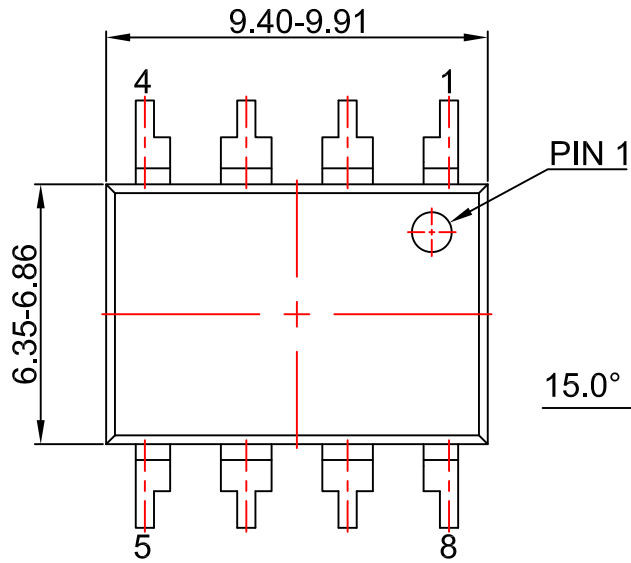

NOTES:

- A) NO STANDARD APPLIES TO THIS PACKAGE
- B) ALL DIMENSIONS ARE IN MILLIMETERS.
- C) DIMENSIONS ARE EXCLUSIVE OF BURRS, MOLD FLASH, AND TIE BAR EXTRUSION
- D) DRAWING FILENAME AND REVISION: MKT-N08REV7



ON Semiconductor and  are trademarks of Semiconductor Components Industries, LLC dba ON Semiconductor or its subsidiaries in the United States and/or other countries. ON Semiconductor owns the rights to a number of patents, trademarks, copyrights, trade secrets, and other intellectual property. A listing of ON Semiconductor's product/patent coverage may be accessed at www.onsemi.com/site/pdf/Patent-Marking.pdf. ON Semiconductor reserves the right to make changes without further notice to any products herein. ON Semiconductor makes no warranty, representation or guarantee regarding the suitability of its products for any particular purpose, nor does ON Semiconductor assume any liability arising out of the application or use of any product or circuit, and specifically disclaims any and all liability, including without limitation special, consequential or incidental damages. Buyer is responsible for its products and applications using ON Semiconductor products, including compliance with all laws, regulations and safety requirements or standards, regardless of any support or applications information provided by ON Semiconductor. "Typical" parameters which may be provided in ON Semiconductor data sheets and/or specifications can and do vary in different applications and actual performance may vary over time. All operating parameters, including "Typicals" must be validated for each customer application by customer's technical experts. ON Semiconductor does not convey any license under its patent rights nor the rights of others. ON Semiconductor products are not designed, intended, or authorized for use as a critical component in life support systems or any FDA Class 3 medical devices or medical devices with a same or similar classification in a foreign jurisdiction or any devices intended for implantation in the human body. Should Buyer purchase or use ON Semiconductor products for any such unintended or unauthorized application, Buyer shall indemnify and hold ON Semiconductor and its officers, employees, subsidiaries, affiliates, and distributors harmless against all claims, costs, damages, and expenses, and reasonable attorney fees arising out of, directly or indirectly, any claim of personal injury or death associated with such unintended or unauthorized use, even if such claim alleges that ON Semiconductor was negligent regarding the design or manufacture of the part. ON Semiconductor is an Equal Opportunity/Affirmative Action Employer. This literature is subject to all applicable copyright laws and is not for resale in any manner.

PUBLICATION ORDERING INFORMATION

LITERATURE FULFILLMENT:

Literature Distribution Center for ON Semiconductor
 19521 E. 32nd Pkwy, Aurora, Colorado 80011 USA
Phone: 303-675-2175 or 800-344-3860 Toll Free USA/Canada
Fax: 303-675-2176 or 800-344-3867 Toll Free USA/Canada
Email: orderlit@onsemi.com

N. American Technical Support: 800-282-9855 Toll Free
 USA/Canada
Europe, Middle East and Africa Technical Support:
 Phone: 421 33 790 2910
Japan Customer Focus Center
 Phone: 81-3-5817-1050

ON Semiconductor Website: www.onsemi.com
Order Literature: <http://www.onsemi.com/orderlit>
 For additional information, please contact your local Sales Representative

OUR CERTIFICATE

DiGi provide top-quality products and perfect service for customer worldwide through standardization, technological innovation and continuous improvement. DiGi through third-party certification, we strictly control the quality of products and services. Welcome your RFQ to

Email: Info@DiGi-Electronics.com



Tel: +00 852-30501935

RFQ Email: Info@DiGi-Electronics.com

DiGi is a global authorized distributor of electronic components.