

# MC1403P1 Datasheet

[www.digi-electronics.com](http://www.digi-electronics.com)

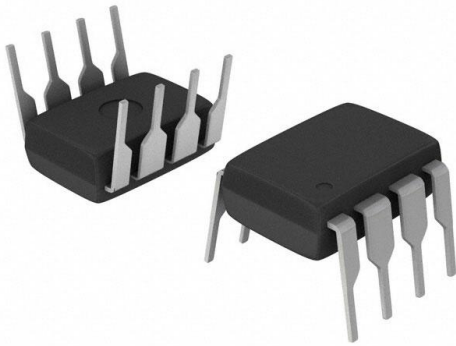

<https://www.DiGi-Electronics.com>

DiGi Electronics Part Number	MC1403P1-DG
Manufacturer	<a href="#">onsemi</a>
Manufacturer Product Number	MC1403P1
Description	IC VREF SERIES 1% 8DIP
Detailed Description	Series Voltage Reference IC Fixed 2.5V V $\pm$ 1% 10 mA 8-PDIP

This model MC1403P1 is available at DiGi Electronics.

DiGi Electronics offers a global database of semiconductor and electronic component datasheets.

We welcome your inquiries regarding pricing, lead time, or other product-related questions.

 [Request a Quote](#)

 [Datasheet Search](#)



Tel: +00 852-30501935

RFQ Email: [Info@DiGi-Electronics.com](mailto:Info@DiGi-Electronics.com)

DiGi is a global authorized distributor of electronic components.

## Purchase and inquiry

Manufacturer Product Number:

MC1403P1

Series:

-

Reference Type:

Series

Voltage - Output (Min/Fixed):

2.5V

Tolerance:

±1%

Noise - 0.1Hz to 10Hz:

-

Voltage - Input:

4.5V ~ 40V

Operating Temperature:

0°C ~ 70°C (TA)

Package / Case:

8-DIP (0.300", 7.62mm)

Base Product Number:

MC1403P

Manufacturer:

onsemi

Product Status:

Obsolete

Output Type:

Fixed

Current - Output:

10 mA

Temperature Coefficient:

40ppm/°C

Noise - 10Hz to 10kHz:

-

Current - Supply:

1.5mA

Mounting Type:

Through Hole

Supplier Device Package:

8-PDIP

## Environmental & Export classification

RoHS Status:

RoHS non-compliant

REACH Status:

REACH Unaffected

HTSUS:

8542.39.0001

Moisture Sensitivity Level (MSL):

1 (Unlimited)

ECCN:

EAR99

# MC1403, B

## Low Voltage Reference

A precision band-gap voltage reference designed for critical instrumentation and D/A converter applications. This unit is designed to work with D/A converters, up to 12 bits in accuracy, or as a reference for power supply applications.

- Output Voltage: 2.5 V  $\pm$  25 mV
- Input Voltage Range: 4.5 V to 40 V
- Quiescent Current: 1.2 mA Typical
- Output Current: 10 mA
- Temperature Coefficient: 10 ppm/ $^{\circ}$ C Typical
- Guaranteed Temperature Drift Specification
- Equivalent to AD580
- Standard 8-Pin DIP, and 8-Pin SOIC Package

### Typical Applications

- Voltage Reference for 8 to 12 Bit D/A Converters
- Low  $T_C$  Zener Replacement
- High Stability Current Reference
- Voltmeter System Reference
- Pb-Free Package is Available

### MAXIMUM RATINGS ( $T_A = 25^{\circ}$ C, unless otherwise noted.)

Rating	Symbol	Value	Unit
Input Voltage	$V_I$	40	V
Storage Temperature	$T_{stg}$	-65 to 150	$^{\circ}$ C
Junction Temperature	$T_J$	+175	$^{\circ}$ C
Operating Ambient Temperature Range	$T_A$	-40 to +85	$^{\circ}$ C
MC1403B		0 to +70	$^{\circ}$ C
MC1403			

Maximum ratings are those values beyond which device damage can occur. Maximum ratings applied to the device are individual stress limit values (not normal operating conditions) and are not valid simultaneously. If these limits are exceeded, device functional operation is not implied, damage may occur and reliability may be affected.



**ON Semiconductor**<sup>®</sup>

<http://onsemi.com>

## PRECISION LOW VOLTAGE REFERENCE

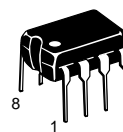

PDIP-8  
P1 SUFFIX  
CASE 626



SOIC-8  
D SUFFIX  
CASE 751

### PIN CONNECTIONS

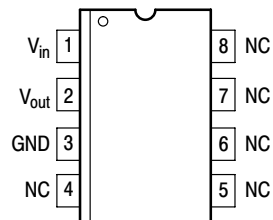

### ORDERING INFORMATION

See detailed ordering and shipping information in the package dimensions section on page 6 of this data sheet.

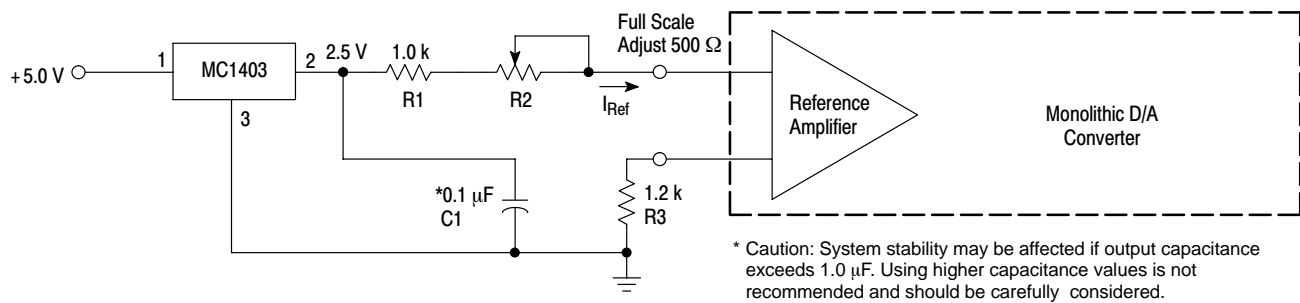
**MC1403, B****Figure 1. A Reference for Monolithic D/A Converters****Providing the Reference Current for ON Semiconductor Monolithic D/A Converters**

The MC1403 makes an ideal reference for many monolithic D/A converters, requiring a stable current reference of nominally 2.0 mA. This can be easily obtained from the MC1403 with the addition of a series resistor, R1. A variable resistor, R2, is recommended to provide means for full-scale adjust on the D/A converter.

The resistor R3 improves temperature performance by matching the impedance on both inputs of the D/A reference amplifier. The capacitor decouples any noise present on the reference line. It is essential if the D/A converter is located any appreciable distance from the reference.

A single MC1403 reference can provide the required current input for up to five of the monolithic D/A converters.

**ELECTRICAL CHARACTERISTICS** ( $V_{in} = 15\text{ V}$ ,  $T_A = 25^\circ\text{C}$ , unless otherwise noted.)

Characteristic	Symbol	Min	Typ	Max	Unit
Output Voltage ( $I_O = 0\text{ mA}$ )	$V_{out}$	2.475	2.5	2.525	V
Temperature Coefficient of Output Voltage* MC1403	$\Delta V_O/\Delta T$	–	10	40	ppm/ $^\circ\text{C}$
Output Voltage Change* (Over specified temperature range) MC1403 0 to $+70^\circ\text{C}$ MC1403B $-40$ to $+85^\circ\text{C}$	$\Delta V_O$	–	–	7.0 12.5	mV
Line Regulation ( $I_O = 0\text{ mA}$ ) ( $15\text{ V} \leq V_I \leq 40\text{ V}$ ) ( $4.5\text{ V} \leq V_I \leq 15\text{ V}$ )	$\text{Reg}_{line}$	–	1.2 0.6	4.5 3.0	mV
Load Regulation ( $0\text{ mA} < I_O < 10\text{ mA}$ )	$\text{Reg}_{load}$	–	–	10	mV
Quiescent Current ( $I_O = 0\text{ mA}$ )	$I_Q$	–	1.2	1.5	mA

\*Guaranteed but not tested.

### MC1403, B

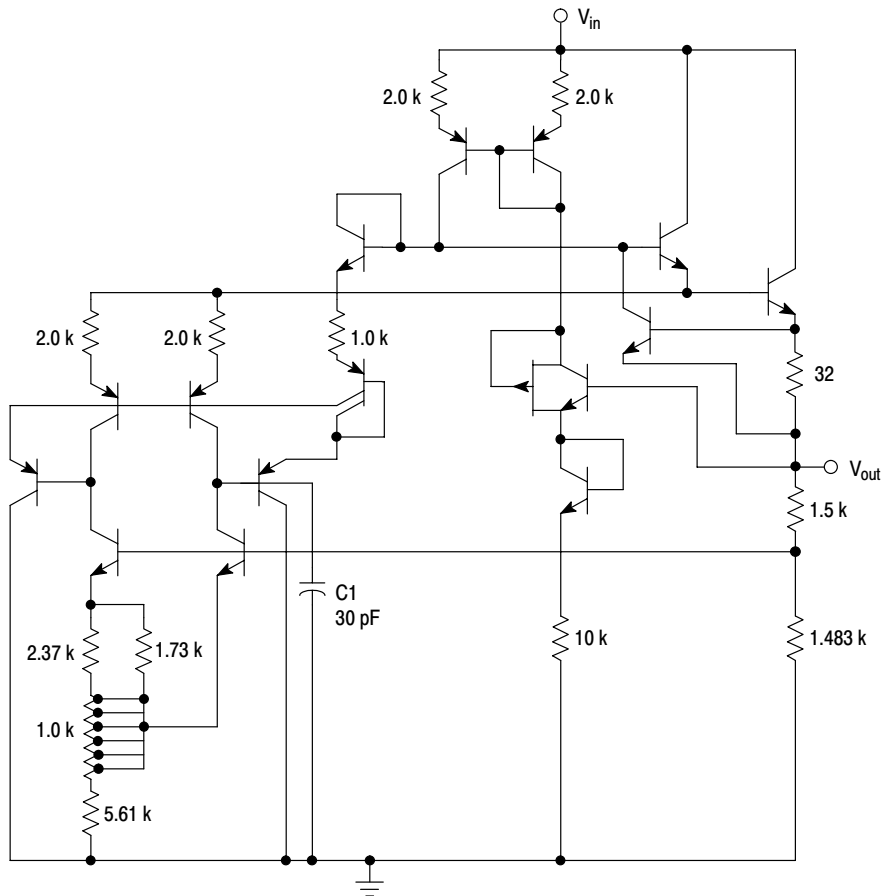

This device contains 15 active transistors.

**Figure 2. MC1403, B Schematic**

### MC1403, B

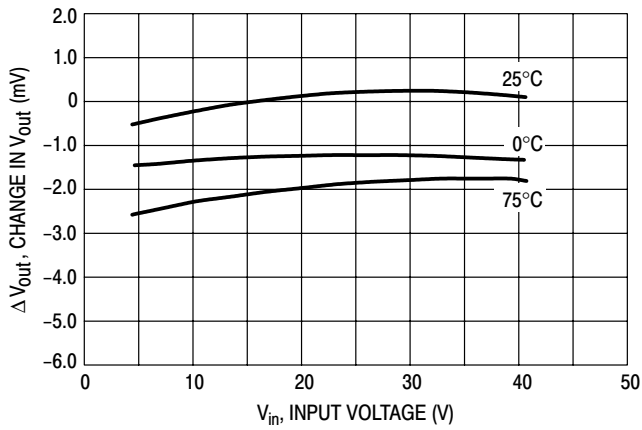

**Figure 3. Typical Change in  $V_{out}$  versus  $V_{in}$**   
(Normalized to  $V_{in} = 15\text{ V}$  @  $T_C = 25^\circ\text{C}$ )

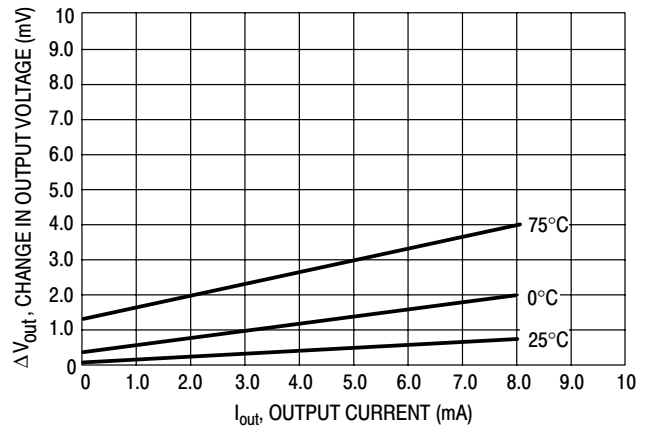

**Figure 4. Change in Output Voltage versus Load Current**  
(Normalized to  $V_{out}$  @  $V_{in} = 15\text{ V}$ ,  $I_{out} = 0\text{ mA}$ )

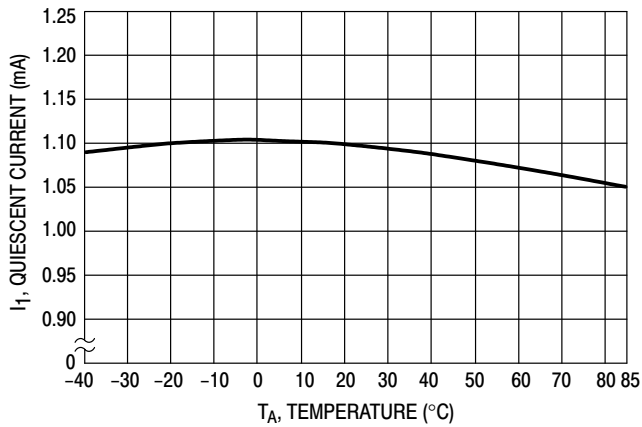

**Figure 5. Quiescent Current versus Temperature**  
( $V_{in} = 15\text{ V}$ ,  $I_{out} = 0\text{ mA}$ )

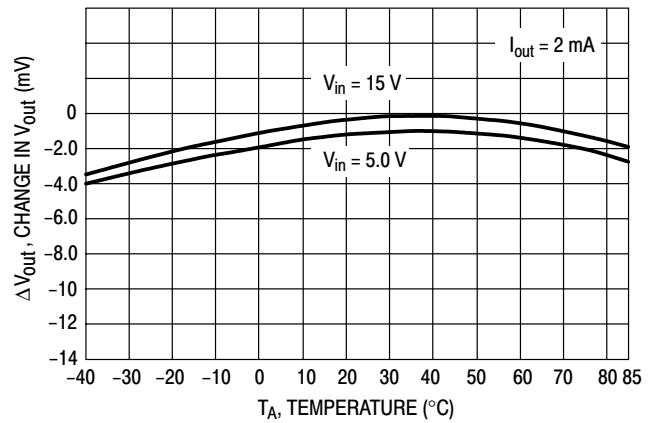

**Figure 6. Change in  $V_{out}$  versus Temperature**  
(Normalized to  $V_{out}$  @  $V_{in} = 15\text{ V}$ )

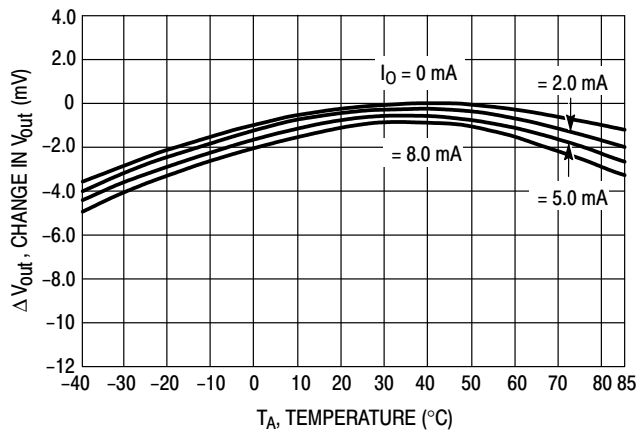

**Figure 7. Change in  $V_{out}$  versus Temperature**  
(Normalized to  $T_A = 25^\circ\text{C}$ ,  $V_{in} = 15\text{ V}$ ,  $I_{out} = 0\text{ mA}$ )

**MC1403, B****3-1/2-Digit Voltmeter – Common Anode Displays, Flashing Overrange**

An example of a 3-1/2-digit voltmeter using the MC14433 is shown in the circuit diagram of Figure 8. The reference voltage for the system uses an MC1403 2.5 V reference IC. The full scale potentiometer can calibrate for a full scale of 199.9 mV or 1.999 V. When switching from 2.0 V to 200 mV operation,  $R_I$  is also changed, as shown on the diagram.

When using  $R_C$  equal to 300 k $\Omega$ , the clock frequency for the system is about 66 kHz. The resulting conversion time is approximately 250 ms.

When the input is overrange, the display flashes on and off. The flashing rate is one-half the conversion rate. This

is done by dividing the EOC pulse rate by 2 with 1/2 MC14013B flip-flop and blanking the display using the blanking input of the MC14543B.

The display uses an LED display with common anode digit lines driven with an MC14543B decoder and an MC1413 LED driver. The MC1413 contains 7 Darlington transistor drivers and resistors to drive the segments of the display. The digit drive is provided by four MPS-A12 Darlington transistors operating in an emitter-follower configuration. The MC14543B, MC14013B and LED displays are referenced to  $V_{EE}$  via Pin 13 of the MC14433. This places the full power supply voltage across the display. The current for the display may be adjusted by the value of the segment resistors shown as 150  $\Omega$  in Figure 8.

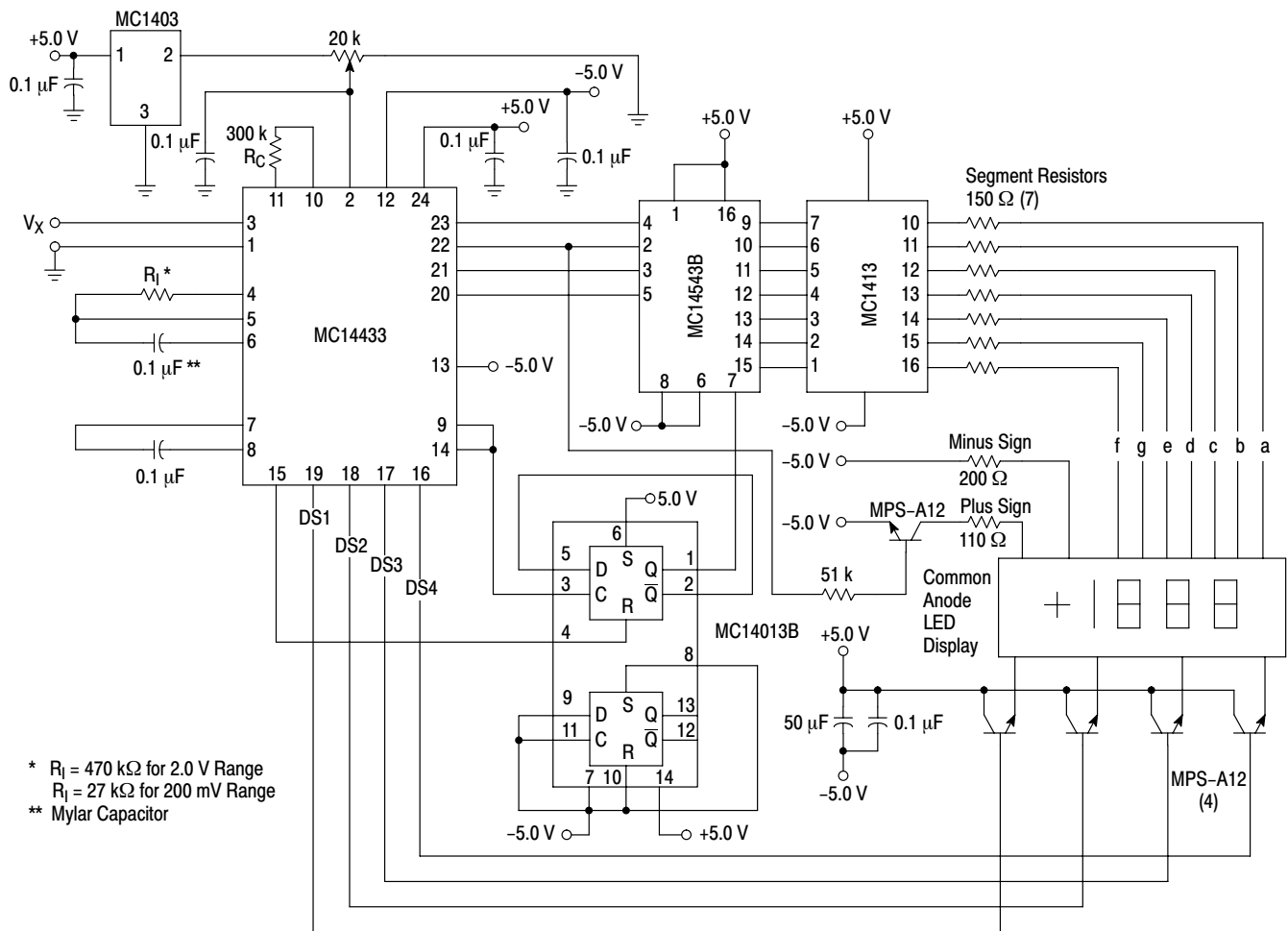

**Figure 8. 3-1/2-Digit Voltmeter**

**MC1403, B****ORDERING INFORMATION**

Device	Package	Operating Temperature Range	Shipping <sup>†</sup>
MC1403D	SOIC-8	$T_A = 0^\circ \text{ to } +70^\circ\text{C}$	98 Units/Rail
MC1403DG	SOIC-8 (Pb-Free)		98 Units/Rail
MC1403DR2	SOIC-8		2500 Tape/Reel
MC1403DR2G	SOIC-8 (Pb-Free)		2500 Tape/Reel
MC1403P1	PDIP-8		1000 Units/Rail
MC1403P1G	PDIP-8 (Pb-Free)		1000 Units/Tubes
MC1403BD	SOIC-8	$T_A = -40^\circ \text{ to } +85^\circ\text{C}$	98 Units/Rail
MC1403BDG	SOIC-8 (Pb-Free)		98 Units/Rail
MC1403BDR2	SOIC-8		2500 Tape/Reel
MC1403BP1	PDIP-8-8		1000 Units/Rail
MC1403BP1G	PDIP-8-8 (Pb-Free)		1000 Units/Rail

<sup>†</sup>For information on tape and reel specifications, including part orientation and tape sizes, please refer to our Tape and Reel Packaging Specifications Brochure, BRD8011/D.



**MECHANICAL CASE OUTLINE  
PACKAGE DIMENSIONS**

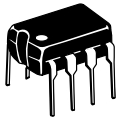

SCALE 1:1

**PDIP-8**  
CASE 626-05  
ISSUE P

DATE 22 APR 2015

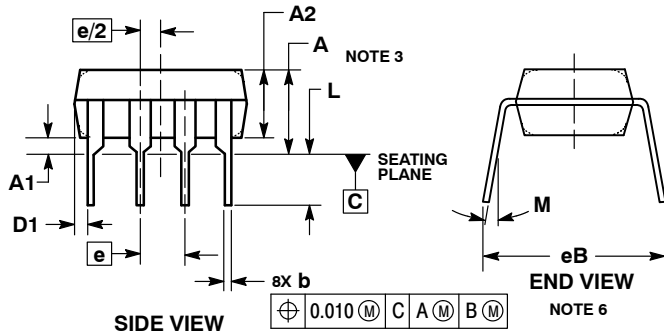
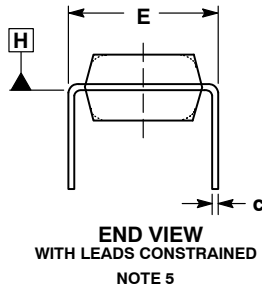
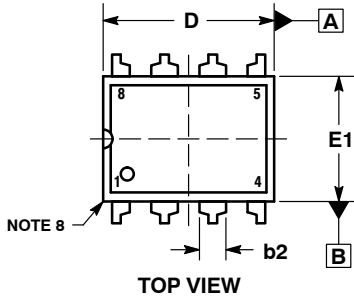

NOTES:

1. DIMENSIONING AND TOLERANCING PER ASME Y14.5M, 1994.
2. CONTROLLING DIMENSION: INCHES.
3. DIMENSIONS A, A1 AND L ARE MEASURED WITH THE PACKAGE SEATED IN JEDEC SEATING PLANE GAUGE GS-3.
4. DIMENSIONS D, D1 AND E1 DO NOT INCLUDE MOLD FLASH OR PROTRUSIONS. MOLD FLASH OR PROTRUSIONS ARE NOT TO EXCEED 0.10 INCH.
5. DIMENSION E IS MEASURED AT A POINT 0.015 BELOW DATUM PLANE H WITH THE LEADS CONSTRAINED PERPENDICULAR TO DATUM C.
6. DIMENSION eB IS MEASURED AT THE LEAD TIPS WITH THE LEADS UNCONSTRAINED.
7. DATUM PLANE H IS COINCIDENT WITH THE BOTTOM OF THE LEADS, WHERE THE LEADS EXIT THE BODY.
8. PACKAGE CONTOUR IS OPTIONAL (ROUNDED OR SQUARE CORNERS).

DIM	INCHES		MILLIMETERS	
	MIN	MAX	MIN	MAX
A	----	0.210	----	5.33
A1	0.015	----	0.38	----
A2	0.115	0.195	2.92	4.95
b	0.014	0.022	0.35	0.56
b2	0.060 TYP		1.52 TYP	
C	0.008	0.014	0.20	0.36
D	0.355	0.400	9.02	10.16
D1	0.005	----	0.13	----
E	0.300	0.325	7.62	8.26
E1	0.240	0.280	6.10	7.11
e	0.100 BSC		2.54 BSC	
eB	----	0.430	----	10.92
L	0.115	0.150	2.92	3.81
M	----	10°	----	10°

**GENERIC MARKING DIAGRAM\***

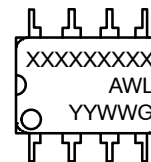

- XXXX = Specific Device Code
- A = Assembly Location
- WL = Wafer Lot
- YY = Year
- WW = Work Week
- G = Pb-Free Package

\*This information is generic. Please refer to device data sheet for actual part marking. Pb-Free indicator, "G" or microdot "•", may or may not be present. Some products may not follow the Generic Marking.

- STYLE 1:  
PIN 1. AC IN  
2. DC + IN  
3. DC - IN  
4. AC IN  
5. GROUND  
6. OUTPUT  
7. AUXILIARY  
8. V<sub>CC</sub>

<b>DOCUMENT NUMBER:</b>	<b>98ASB42420B</b>	Electronic versions are uncontrolled except when accessed directly from the Document Repository. Printed versions are uncontrolled except when stamped "CONTROLLED COPY" in red.
<b>DESCRIPTION:</b>	<b>PDIP-8</b>	<b>PAGE 1 OF 1</b>

onsemi and ONSEMI are trademarks of Semiconductor Components Industries, LLC dba onsemi or its subsidiaries in the United States and/or other countries. onsemi reserves the right to make changes without further notice to any products herein. onsemi makes no warranty, representation or guarantee regarding the suitability of its products for any particular purpose, nor does onsemi assume any liability arising out of the application or use of any product or circuit, and specifically disclaims any and all liability, including without limitation special, consequential or incidental damages. onsemi does not convey any license under its patent rights nor the rights of others.



**MECHANICAL CASE OUTLINE  
PACKAGE DIMENSIONS**

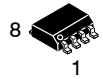

SCALE 1:1

**SOIC-8 NB**  
CASE 751-07  
ISSUE AK

DATE 16 FEB 2011

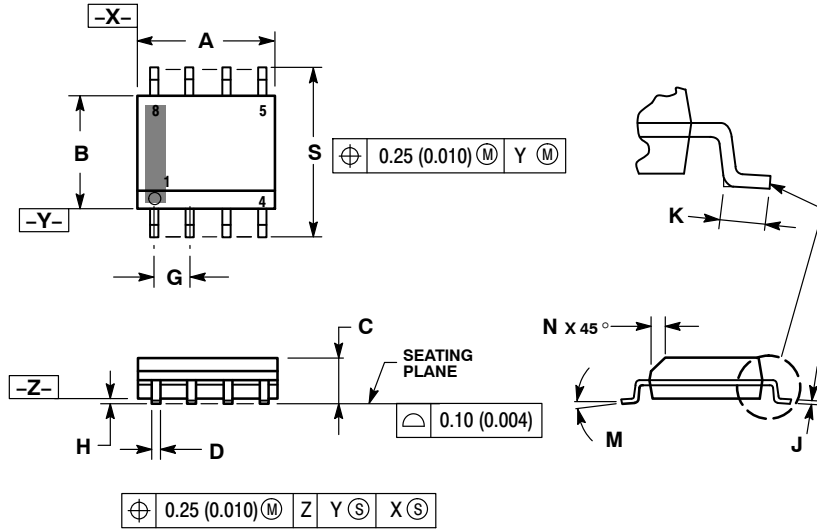

**NOTES:**

1. DIMENSIONING AND TOLERANCING PER ANSI Y14.5M, 1982.
2. CONTROLLING DIMENSION: MILLIMETER.
3. DIMENSION A AND B DO NOT INCLUDE MOLD PROTRUSION.
4. MAXIMUM MOLD PROTRUSION 0.15 (0.006) PER SIDE.
5. DIMENSION D DOES NOT INCLUDE DAMBAR PROTRUSION. ALLOWABLE DAMBAR PROTRUSION SHALL BE 0.127 (0.005) TOTAL IN EXCESS OF THE D DIMENSION AT MAXIMUM MATERIAL CONDITION.
6. 751-01 THRU 751-06 ARE OBSOLETE. NEW STANDARD IS 751-07.

DIM	MILLIMETERS		INCHES	
	MIN	MAX	MIN	MAX
A	4.80	5.00	0.189	0.197
B	3.80	4.00	0.150	0.157
C	1.35	1.75	0.053	0.069
D	0.33	0.51	0.013	0.020
G	1.27 BSC		0.050 BSC	
H	0.10	0.25	0.004	0.010
J	0.19	0.25	0.007	0.010
K	0.40	1.27	0.016	0.050
M	0°	8°	0°	8°
N	0.25	0.50	0.010	0.020
S	5.80	6.20	0.228	0.244

**GENERIC MARKING DIAGRAM\***

**SOLDERING FOOTPRINT\***

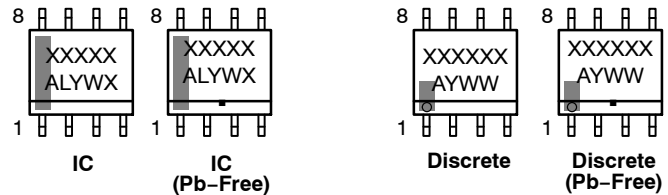
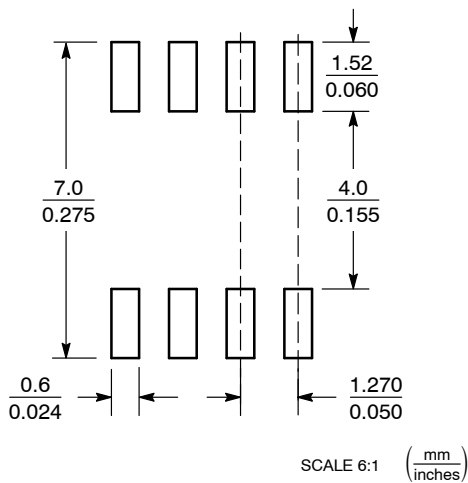

XXXXXX = Specific Device Code  
 A = Assembly Location  
 L = Wafer Lot  
 Y = Year  
 W = Work Week  
 ■ = Pb-Free Package

XXXXXX = Specific Device Code  
 A = Assembly Location  
 Y = Year  
 WW = Work Week  
 ■ = Pb-Free Package

\*This information is generic. Please refer to device data sheet for actual part marking. Pb-Free indicator, "G" or microdot "•", may or may not be present. Some products may not follow the Generic Marking.

\*For additional information on our Pb-Free strategy and soldering details, please download the onsemi Soldering and Mounting Techniques Reference Manual, SOLDERRM/D.

**STYLES ON PAGE 2**

<b>DOCUMENT NUMBER:</b>	<b>98ASB42564B</b>	Electronic versions are uncontrolled except when accessed directly from the Document Repository. Printed versions are uncontrolled except when stamped "CONTROLLED COPY" in red.
<b>DESCRIPTION:</b>	<b>SOIC-8 NB</b>	<b>PAGE 1 OF 2</b>

onsemi and onsemi are trademarks of Semiconductor Components Industries, LLC dba onsemi or its subsidiaries in the United States and/or other countries. onsemi reserves the right to make changes without further notice to any products herein. onsemi makes no warranty, representation or guarantee regarding the suitability of its products for any particular purpose, nor does onsemi assume any liability arising out of the application or use of any product or circuit, and specifically disclaims any and all liability, including without limitation special, consequential or incidental damages. onsemi does not convey any license under its patent rights nor the rights of others.

**SOIC-8 NB**  
**CASE 751-07**  
**ISSUE AK**

DATE 16 FEB 2011

<p><b>STYLE 1:</b>            PIN 1. EMITTER            2. COLLECTOR            3. COLLECTOR            4. EMITTER            5. EMITTER            6. BASE            7. BASE            8. EMITTER</p>	<p><b>STYLE 2:</b>            PIN 1. COLLECTOR, DIE, #1            2. COLLECTOR, #1            3. COLLECTOR, #2            4. COLLECTOR, #2            5. BASE, #2            6. EMITTER, #2            7. BASE, #1            8. EMITTER, #1</p>	<p><b>STYLE 3:</b>            PIN 1. DRAIN, DIE #1            2. DRAIN, #1            3. DRAIN, #2            4. DRAIN, #2            5. GATE, #2            6. SOURCE, #2            7. GATE, #1            8. SOURCE, #1</p>	<p><b>STYLE 4:</b>            PIN 1. ANODE            2. ANODE            3. ANODE            4. ANODE            5. ANODE            6. ANODE            7. ANODE            8. COMMON CATHODE</p>
<p><b>STYLE 5:</b>            PIN 1. DRAIN            2. DRAIN            3. DRAIN            4. DRAIN            5. GATE            6. GATE            7. SOURCE            8. SOURCE</p>	<p><b>STYLE 6:</b>            PIN 1. SOURCE            2. DRAIN            3. DRAIN            4. SOURCE            5. SOURCE            6. GATE            7. GATE            8. SOURCE</p>	<p><b>STYLE 7:</b>            PIN 1. INPUT            2. EXTERNAL BYPASS            3. THIRD STAGE SOURCE            4. GROUND            5. DRAIN            6. GATE 3            7. SECOND STAGE Vd            8. FIRST STAGE Vd</p>	<p><b>STYLE 8:</b>            PIN 1. COLLECTOR, DIE #1            2. BASE, #1            3. BASE, #2            4. COLLECTOR, #2            5. COLLECTOR, #2            6. EMITTER, #2            7. EMITTER, #1            8. COLLECTOR, #1</p>
<p><b>STYLE 9:</b>            PIN 1. EMITTER, COMMON            2. COLLECTOR, DIE #1            3. COLLECTOR, DIE #2            4. EMITTER, COMMON            5. EMITTER, COMMON            6. BASE, DIE #2            7. BASE, DIE #1            8. EMITTER, COMMON</p>	<p><b>STYLE 10:</b>            PIN 1. GROUND            2. BIAS 1            3. OUTPUT            4. GROUND            5. GROUND            6. BIAS 2            7. INPUT            8. GROUND</p>	<p><b>STYLE 11:</b>            PIN 1. SOURCE 1            2. GATE 1            3. SOURCE 2            4. GATE 2            5. DRAIN 2            6. DRAIN 2            7. DRAIN 1            8. DRAIN 1</p>	<p><b>STYLE 12:</b>            PIN 1. SOURCE            2. SOURCE            3. SOURCE            4. GATE            5. DRAIN            6. DRAIN            7. DRAIN            8. DRAIN</p>
<p><b>STYLE 13:</b>            PIN 1. N.C.            2. SOURCE            3. SOURCE            4. GATE            5. DRAIN            6. DRAIN            7. DRAIN            8. DRAIN</p>	<p><b>STYLE 14:</b>            PIN 1. N-SOURCE            2. N-GATE            3. P-SOURCE            4. P-GATE            5. P-DRAIN            6. P-DRAIN            7. N-DRAIN            8. N-DRAIN</p>	<p><b>STYLE 15:</b>            PIN 1. ANODE 1            2. ANODE 1            3. ANODE 1            4. ANODE 1            5. CATHODE, COMMON            6. CATHODE, COMMON            7. CATHODE, COMMON            8. CATHODE, COMMON</p>	<p><b>STYLE 16:</b>            PIN 1. EMITTER, DIE #1            2. BASE, DIE #1            3. EMITTER, DIE #2            4. BASE, DIE #2            5. COLLECTOR, DIE #2            6. COLLECTOR, DIE #2            7. COLLECTOR, DIE #1            8. COLLECTOR, DIE #1</p>
<p><b>STYLE 17:</b>            PIN 1. VCC            2. V2OUT            3. V1OUT            4. TXE            5. RXE            6. VEE            7. GND            8. ACC</p>	<p><b>STYLE 18:</b>            PIN 1. ANODE            2. ANODE            3. SOURCE            4. GATE            5. DRAIN            6. DRAIN            7. CATHODE            8. CATHODE</p>	<p><b>STYLE 19:</b>            PIN 1. SOURCE 1            2. GATE 1            3. SOURCE 2            4. GATE 2            5. DRAIN 2            6. MIRROR 2            7. DRAIN 1            8. MIRROR 1</p>	<p><b>STYLE 20:</b>            PIN 1. SOURCE (N)            2. GATE (N)            3. SOURCE (P)            4. GATE (P)            5. DRAIN            6. DRAIN            7. DRAIN            8. DRAIN</p>
<p><b>STYLE 21:</b>            PIN 1. CATHODE 1            2. CATHODE 2            3. CATHODE 3            4. CATHODE 4            5. CATHODE 5            6. COMMON ANODE            7. COMMON ANODE            8. CATHODE 6</p>	<p><b>STYLE 22:</b>            PIN 1. I/O LINE 1            2. COMMON CATHODE/VCC            3. COMMON CATHODE/VCC            4. I/O LINE 3            5. COMMON ANODE/GND            6. I/O LINE 4            7. I/O LINE 5            8. COMMON ANODE/GND</p>	<p><b>STYLE 23:</b>            PIN 1. LINE 1 IN            2. COMMON ANODE/GND            3. COMMON ANODE/GND            4. LINE 2 IN            5. LINE 2 OUT            6. COMMON ANODE/GND            7. COMMON ANODE/GND            8. LINE 1 OUT</p>	<p><b>STYLE 24:</b>            PIN 1. BASE            2. EMITTER            3. COLLECTOR/ANODE            4. COLLECTOR/ANODE            5. CATHODE            6. CATHODE            7. COLLECTOR/ANODE            8. COLLECTOR/ANODE</p>
<p><b>STYLE 25:</b>            PIN 1. VIN            2. N/C            3. REXT            4. GND            5. IOUT            6. IOUT            7. IOUT            8. IOUT</p>	<p><b>STYLE 26:</b>            PIN 1. GND            2. dv/dt            3. ENABLE            4. ILIMIT            5. SOURCE            6. SOURCE            7. SOURCE            8. VCC</p>	<p><b>STYLE 27:</b>            PIN 1. ILIMIT            2. OVLO            3. UVLO            4. INPUT+            5. SOURCE            6. SOURCE            7. SOURCE            8. DRAIN</p>	<p><b>STYLE 28:</b>            PIN 1. SW_TO_GND            2. DASIC OFF            3. DASIC_SW_DET            4. GND            5. V_MON            6. VBULK            7. VBULK            8. VIN</p>
<p><b>STYLE 29:</b>            PIN 1. BASE, DIE #1            2. EMITTER, #1            3. BASE, #2            4. EMITTER, #2            5. COLLECTOR, #2            6. COLLECTOR, #2            7. COLLECTOR, #1            8. COLLECTOR, #1</p>	<p><b>STYLE 30:</b>            PIN 1. DRAIN 1            2. DRAIN 1            3. GATE 2            4. SOURCE 2            5. SOURCE 1/DRAIN 2            6. SOURCE 1/DRAIN 2            7. SOURCE 1/DRAIN 2            8. GATE 1</p>		

<b>DOCUMENT NUMBER:</b>	<b>98ASB42564B</b>	Electronic versions are uncontrolled except when accessed directly from the Document Repository. Printed versions are uncontrolled except when stamped "CONTROLLED COPY" in red.
<b>DESCRIPTION:</b>	<b>SOIC-8 NB</b>	<b>PAGE 2 OF 2</b>

onsemi and Onsemi are trademarks of Semiconductor Components Industries, LLC dba onsemi or its subsidiaries in the United States and/or other countries. onsemi reserves the right to make changes without further notice to any products herein. onsemi makes no warranty, representation or guarantee regarding the suitability of its products for any particular purpose, nor does onsemi assume any liability arising out of the application or use of any product or circuit, and specifically disclaims any and all liability, including without limitation special, consequential or incidental damages. onsemi does not convey any license under its patent rights nor the rights of others.

**onsemi**, **Onsemi**, and other names, marks, and brands are registered and/or common law trademarks of Semiconductor Components Industries, LLC dba "**onsemi**" or its affiliates and/or subsidiaries in the United States and/or other countries. **onsemi** owns the rights to a number of patents, trademarks, copyrights, trade secrets, and other intellectual property. A listing of **onsemi**'s product/patent coverage may be accessed at [www.onsemi.com/site/pdf/Patent-Marking.pdf](http://www.onsemi.com/site/pdf/Patent-Marking.pdf). **onsemi** reserves the right to make changes at any time to any products or information herein, without notice. The information herein is provided "as-is" and **onsemi** makes no warranty, representation or guarantee regarding the accuracy of the information, product features, availability, functionality, or suitability of its products for any particular purpose, nor does **onsemi** assume any liability arising out of the application or use of any product or circuit, and specifically disclaims any and all liability, including without limitation special, consequential or incidental damages. Buyer is responsible for its products and applications using **onsemi** products, including compliance with all laws, regulations and safety requirements or standards, regardless of any support or applications information provided by **onsemi**. "Typical" parameters which may be provided in **onsemi** data sheets and/or specifications can and do vary in different applications and actual performance may vary over time. All operating parameters, including "Typicals" must be validated for each customer application by customer's technical experts. **onsemi** does not convey any license under any of its intellectual property rights nor the rights of others. **onsemi** products are not designed, intended, or authorized for use as a critical component in life support systems or any FDA Class 3 medical devices or medical devices with a same or similar classification in a foreign jurisdiction or any devices intended for implantation in the human body. Should Buyer purchase or use **onsemi** products for any such unintended or unauthorized application, Buyer shall indemnify and hold **onsemi** and its officers, employees, subsidiaries, affiliates, and distributors harmless against all claims, costs, damages, and expenses, and reasonable attorney fees arising out of, directly or indirectly, any claim of personal injury or death associated with such unintended or unauthorized use, even if such claim alleges that **onsemi** was negligent regarding the design or manufacture of the part. **onsemi** is an Equal Opportunity/Affirmative Action Employer. This literature is subject to all applicable copyright laws and is not for resale in any manner.

#### ADDITIONAL INFORMATION

**TECHNICAL PUBLICATIONS:**

Technical Library: [www.onsemi.com/design/resources/technical-documentation](http://www.onsemi.com/design/resources/technical-documentation)  
onsemi Website: [www.onsemi.com](http://www.onsemi.com)

**ONLINE SUPPORT:** [www.onsemi.com/support](http://www.onsemi.com/support)

For additional information, please contact your local Sales Representative at [www.onsemi.com/support/sales](http://www.onsemi.com/support/sales)

## OUR CERTIFICATE

DiGi provide top-quality products and perfect service for customer worldwide through standardization, technological innovation and continuous improvement. DiGi through third-party certification, we stricly control the quality of products and services. Welcome your RFQ to

Email: [Info@DiGi-Electronics.com](mailto:Info@DiGi-Electronics.com)



Tel: +00 852-30501935

RFQ Email: [Info@DiGi-Electronics.com](mailto:Info@DiGi-Electronics.com)

DiGi is a global authorized distributor of electronic components.