

MC3303DR2 Datasheet

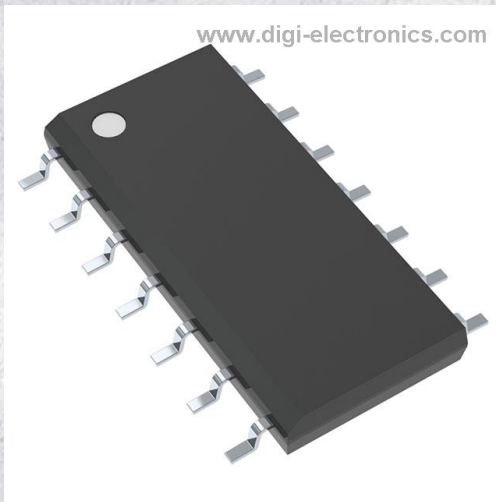

<https://www.DiGi-Electronics.com>

DiGi Electronics Part Number	MC3303DR2-DG
Manufacturer	onsemi
Manufacturer Product Number	MC3303DR2
Description	IC OPAMP QUAD DIFF INPUT 14SOIC
Detailed Description	General Purpose Amplifier 4 Circuit 14-SOIC



Tel: +00 852-30501935

RFQ Email: Info@DiGi-Electronics.com

DiGi is a global authorized distributor of electronic components.

Purchase and inquiry

Manufacturer Product Number:

MC3303DR2

Series:

-

Amplifier Type:

General Purpose

Output Type:

-

Gain Bandwidth Product:

1 MHz

Voltage - Input Offset:

2 mV

Current - Output / Channel:

30 mA

Voltage - Supply Span (Max):

36 V

Mounting Type:

Surface Mount

Supplier Device Package:

14-SOIC

Manufacturer:

onsemi

Product Status:

Obsolete

Number of Circuits:

4

Slew Rate:

0.6V/ μ s

Current - Input Bias:

200 nA

Current - Supply:

2.8mA (x4 Channels)

Voltage - Supply Span (Min):

3 V

Operating Temperature:

-40°C ~ 85°C

Package / Case:

14-SOIC (0.154", 3.90mm Width)

Base Product Number:

MC3303

Environmental & Export classification

RoHS Status:

RoHS non-compliant

REACH Status:

REACH Unaffected

HTSUS:

8542.33.0001

Moisture Sensitivity Level (MSL):

1 (Unlimited)

ECCN:

EAR99

Single Supply Quad Operational Amplifiers

MC3403, MC3303

The MC3403 is a low cost, quad operational amplifier with true differential inputs. The device has electrical characteristics similar to the popular MC1741C. However, the MC3403 has several distinct advantages over standard operational amplifier types in single supply applications. The quad amplifier can operate at supply voltages as low as 3.0 V or as high as 36 V with quiescent currents about one third of those associated with the MC1741C (on a per amplifier basis). The common mode input range includes the negative supply, thereby eliminating the necessity for external biasing components in many applications. The output voltage range also includes the negative power supply voltage.

Features

- Short Circuit Protected Outputs
- Class AB Output Stage for Minimal Crossover Distortion
- True Differential Input Stage
- Single Supply Operation: 3.0 V to 36 V
- Split Supply Operation: ± 1.5 V to ± 18 V
- Low Input Bias Currents: 500 nA Max
- Four Amplifiers Per Package
- Internally Compensated
- Similar Performance to Popular MC1741C
- Industry Standard Pin-outs
- ESD Diodes Added for Increased Ruggedness
- Pb-Free Packages are Available

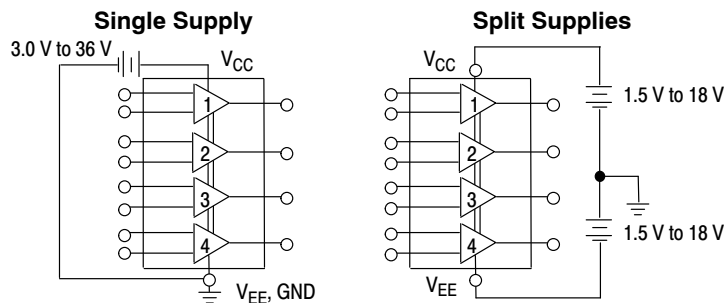

PIN CONNECTIONS

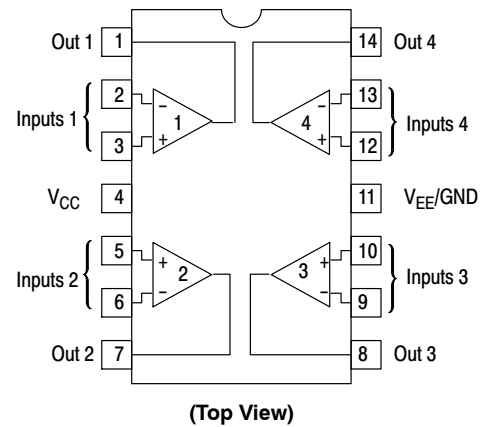

MARKING DIAGRAM

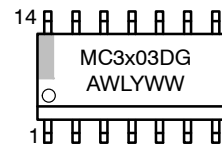

- x = 3 or 4
- A = Assembly Location
- WL = Wafer Lot
- Y = Year
- WW = Work Week

ORDERING INFORMATION

See detailed ordering and shipping information in the package dimensions section on page 8 of this data sheet.

NOTE: Some of the devices on this data sheet have been **DISCONTINUED**. Please refer to the table on page 8.

MC3403, MC3303**MAXIMUM RATINGS**

Symbol	Rating	Value	Unit
V_{CC} V_{CC}, V_{EE}	Power Supply Voltages Single Supply Split Supplies	36 ± 18	Vdc
V_{IDR}	Input Differential Voltage Range (Note 1)	± 36	Vdc
V_{ICR}	Input Common Mode Voltage Range (Notes 1 and 2)	± 18	Vdc
T_{stg}	Storage Temperature Range	-55 to +125	$^{\circ}\text{C}$
T_A	Operating Ambient Temperature Range MC3303 MC3403	-40 to +85 0 to +70	$^{\circ}\text{C}$
T_J	Junction Temperature	150	$^{\circ}\text{C}$

Stresses exceeding those listed in the Maximum Ratings table may damage the device. If any of these limits are exceeded, device functionality should not be assumed, damage may occur and reliability may be affected.

1. Split power supplies.

2. For supply voltages less than ± 18 V, the absolute maximum input voltage is equal to the supply voltage.

MC3403, MC3303**ELECTRICAL CHARACTERISTICS**(V_{CC} = +15 V, V_{EE} = -15 V for MC3403; V_{CC} = +14 V, V_{EE} = GND for MC3303 T_A = 25°C, unless otherwise noted.)

Symbol	Characteristic	MC3403			MC3303			Unit
		Min	Typ	Max	Min	Typ	Max	
V _{IO}	Input Offset Voltage T _A = T _{high} to T _{low} (Note 3)	-	2.0	10	-	2.0	8.0	mV
		-	-	12	-	-	10	
I _{IO}	Input Offset Current T _A = T _{high} to T _{low}	-	30	50	-	30	75	nA
		-	-	200	-	-	250	
A _{VOL}	Large Signal Open Loop Voltage Gain V _O = ±10 V, R _L = 2.0 kΩ T _A = T _{high} to T _{low}	20	200	-	20	200	-	V/mV
		15	-	-	15	-	-	
I _{IB}	Input Bias Current T _A = T _{high} to T _{low}	-	-200	-500	-	-200	-500	nA
		-	-	-800	-	-	-1000	
z _o	Output Impedance f = 20 Hz	-	75	-	-	75	-	Ω
z _i	Input Impedance f = 20 Hz	0.3	1.0	-	0.3	1.0	-	MΩ
V _O	Output Voltage Range R _L = 10 kΩ R _L = 2.0 kΩ R _L = 2.0 kΩ, T _A = T _{high} to T _{low}	±12	±13.5	-	12	12.5	-	V
		±10	±13	-	10	12	-	
		±10	-	-	10	-	-	
V _{ICR}	Input Common Mode Voltage Range	+13 V -V _{EE}	+13 V -V _{EE}	-	+12 V -V _{EE}	+12.5 V -V _{EE}	-	V
CMR	Common Mode Rejection R _S ≤ 10 kΩ	70	90	-	70	90	-	dB
I _{CC} , I _{EE}	Power Supply Current (V _O = 0) R _L = ∞	-	2.8	7.0	-	2.8	7.0	mA
I _{SC}	Individual Output Short-Circuit Current (Note 4)	±10	±20	±45	±10	±30	±45	mA
PSRR+	Positive Power Supply Rejection Ratio	-	30	150	-	30	150	μV/V
PSRR-	Negative Power Supply Rejection Ratio	-	30	150	-	30	150	μV/V
ΔI _{IO} /ΔT	Average Temperature Coefficient of Input Offset Current T _A = T _{high} to T _{low}	-	50	-	-	50	-	pA/°C
ΔV _{IO} /ΔT	Average Temperature Coefficient of Input Offset Voltage T _A = T _{high} to T _{low}	-	10	-	-	10	-	μV/°C
BW _p	Power Bandwidth A _V = 1, R _L = 10 kΩ, V _O = 20 V(p-p), THD = 5%	-	9.0	-	-	9.0	-	kHz
BW	Small-Signal Bandwidth A _V = 1, R _L = 10 kΩ, V _O = 50 mV	-	1.0	-	-	1.0	-	MHz
SR	Slew Rate A _V = 1, V _i = -10 V to +10 V	-	0.6	-	-	0.6	-	V/μs
t _{TLH}	Rise Time A _V = 1, R _L = 10 kΩ, V _O = 50 mV	-	0.35	-	-	0.35	-	μs
t _{TLH}	Fall Time A _V = 1, R _L = 10 kΩ, V _O = 50 mV	-	0.35	-	-	0.35	-	μs
os	Overshoot A _V = 1, R _L = 10 kΩ, V _O = 50 mV	-	20	-	-	20	-	%
φ _m	Phase Margin A _V = 1, R _L = 2.0 kΩ, V _O = 200 pF	-	60	-	-	60	-	°
-	Crossover Distortion (V _{in} = 30 mV _{pp} , V _{out} = 2.0 V _{pp} , f = 10 kHz)	-	1.0	-	-	1.0	-	%

Product parametric performance is indicated in the Electrical Characteristics for the listed test conditions, unless otherwise noted. Product performance may not be indicated by the Electrical Characteristics if operated under different conditions.

3. MC3303: T_{low} = -40°C, T_{high} = +85°C, MC3403: T_{low} = 0°C, T_{high} = +70°C

4. Not to exceed maximum package power dissipation.

MC3403, MC3303

ELECTRICAL CHARACTERISTICS ($V_{CC} = 5.0\text{ V}$, $V_{EE} = \text{GND}$, $T_A = 25^\circ\text{C}$, unless otherwise noted.)

Symbol	Characteristic	MC3403			MC3303			Unit
		Min	Typ	Max	Min	Typ	Max	
V_{IO}	Input Offset Voltage	-	2.0	10	-	-	10	mV
I_{IO}	Input Offset Current	-	30	50	-	-	75	nA
I_{IB}	Input Bias Current	-	-200	-500	-	-	-500	nA
A_{VOL}	Large Signal Open Loop Voltage Gain $R_L = 2.0\text{ k}\Omega$	10	200	-	10	200	-	V/mV
PSRR	Power Supply Rejection Ratio	-	-	150	-	-	150	$\mu\text{V/V}$
V_{OR}	Output Voltage Range (Note 5) $R_L = 10\text{ k}\Omega$, $V_{CC} = 5.0\text{ V}$ $R_L = 10\text{ k}\Omega$, $5.0 \leq V_{CC} \leq 30\text{ V}$	3.3 $V_{CC}-2.0$	3.5 $V_{CC}-1.7$	- -	3.3 $V_{CC}-2.0$	3.5 $V_{CC}-1.7$	- -	V_{pp}
I_{CC}	Power Supply Current	-	2.5	7.0	-	2.5	7.0	mA
CS	Channel Separation $f = 1.0\text{ kHz to }20\text{ kHz}$ (Input Referenced)	-	-120	-	-	-120	-	dB

5. Output will swing to ground with a 10 kΩ pull down resistor.

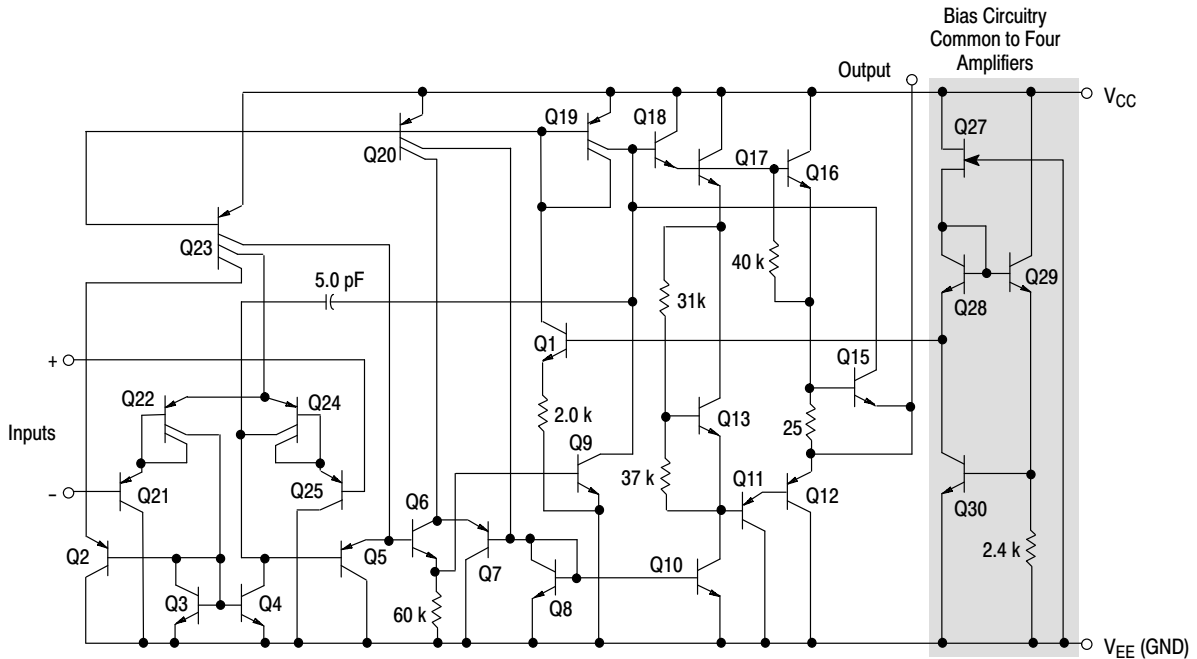
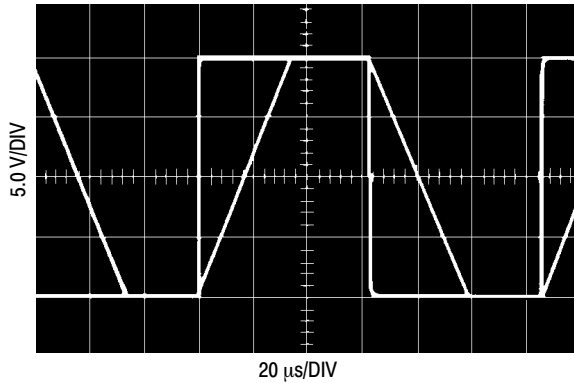

Figure 1. Representative Schematic Diagram
(1/4 of Circuit Shown)

MC3403, MC3303**CIRCUIT DESCRIPTION****Figure 2. Inverter Pulse Response**

The MC3403/3303 is made using four internally compensated, two-stage operational amplifiers. The first stage of each consists of differential input device Q24 and Q22 with input buffer transistors Q25 and Q21 and the differential to single ended converter Q3 and Q4. The first

stage performs not only the first stage gain function but also performs the level shifting and Transconductance reduction functions. By reducing the Transconductance, a smaller compensation capacitor (only 5.0 pF) can be employed, thus saving chip area. The Transconductance reduction is accomplished by splitting the collectors of Q24 and Q22. Another feature of this input stage is that the input common mode range can include the negative supply or ground, in single supply operation, without saturating either the input devices or the differential to single-ended converter. The second stage consists of a standard current source load amplifier stage.

The output stage is unique because it allows the output to swing to ground in single supply operation and yet does not exhibit any crossover distortion in split supply operation. This is possible because Class AB operation is utilized.

Each amplifier is biased from an internal voltage regulator which has a low temperature coefficient, thus giving each amplifier good temperature characteristics as well as excellent power supply rejection.

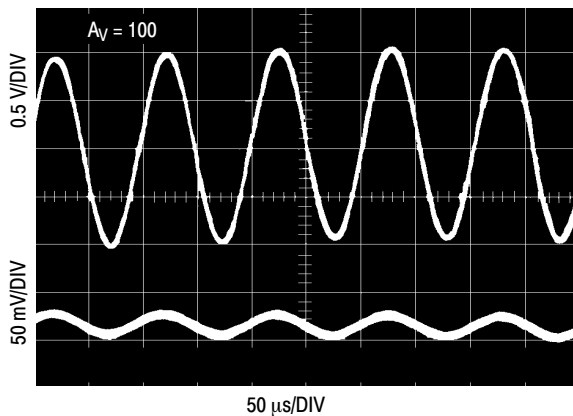
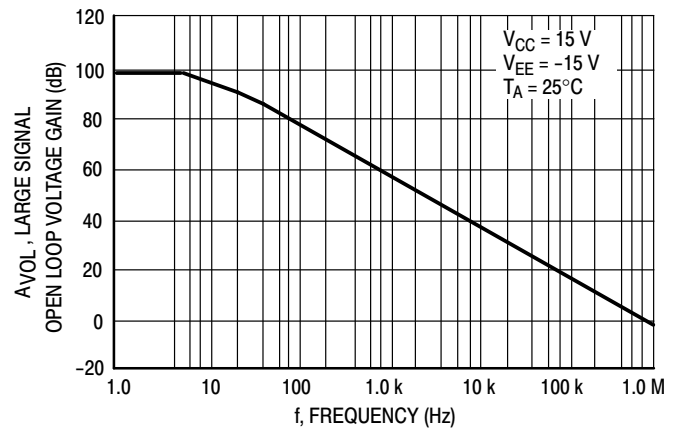
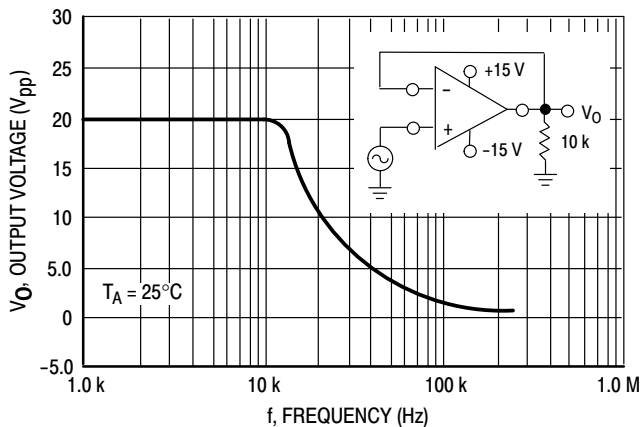
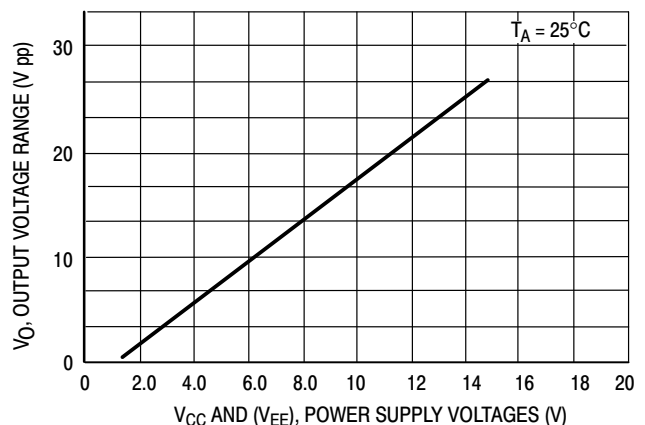
**Figure 3. Sine Wave Response****Figure 4. Open Loop Frequency Response****Figure 5. Power Bandwidth****Figure 6. Output Swing versus Supply Voltage**

MC3403, MC3303

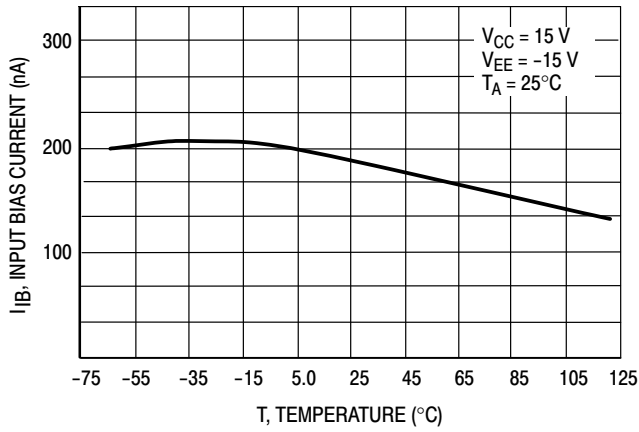

Figure 7. Input Bias Current versus Temperature

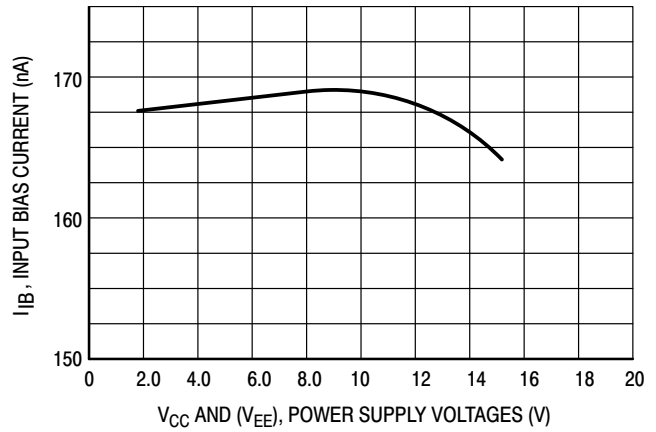

Figure 8. Input Bias Current versus Supply Voltage

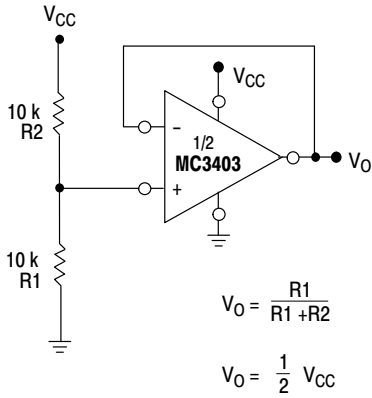

Figure 9. Voltage Reference

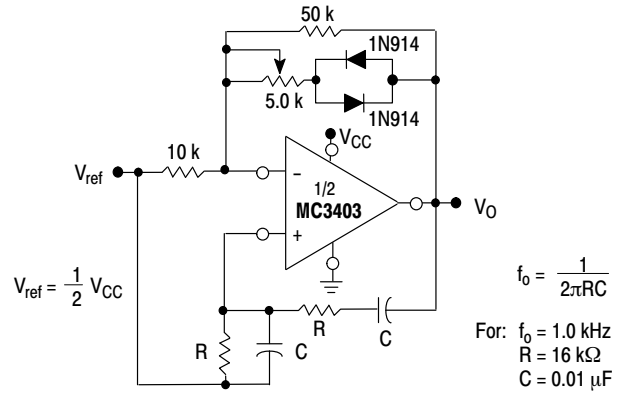

Figure 10. Wien Bridge Oscillator

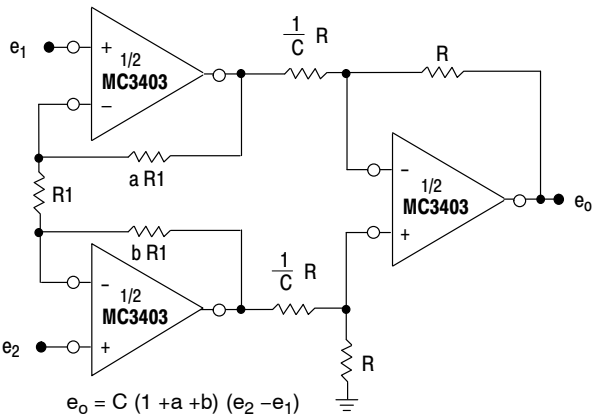

Figure 11. High Impedance Differential Amplifier

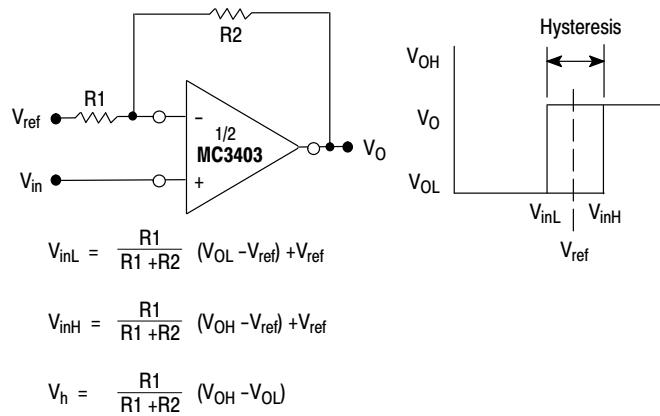

Figure 12. Comparator with Hysteresis

MC3403, MC3303

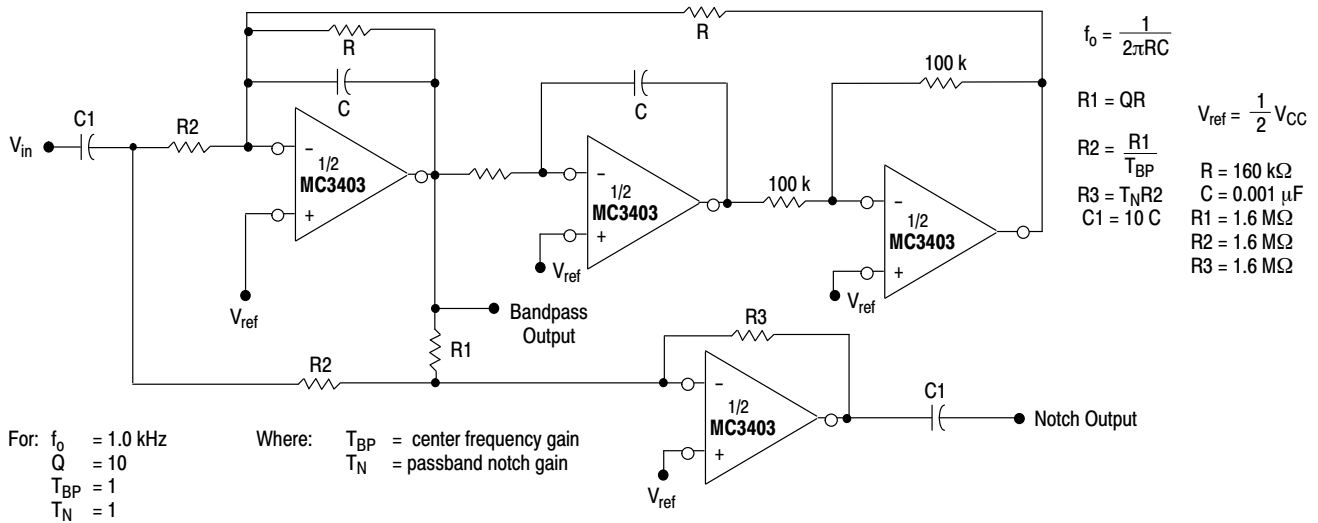

Figure 13. Bi-Quad Filter

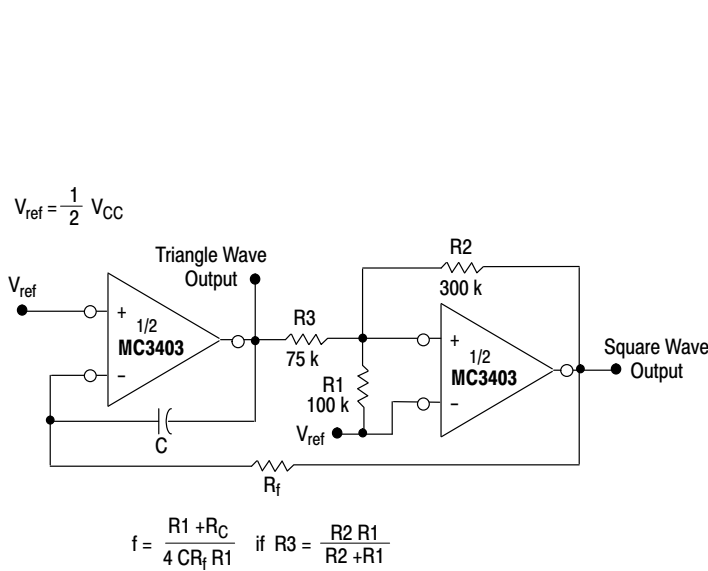

Figure 14. Function Generator

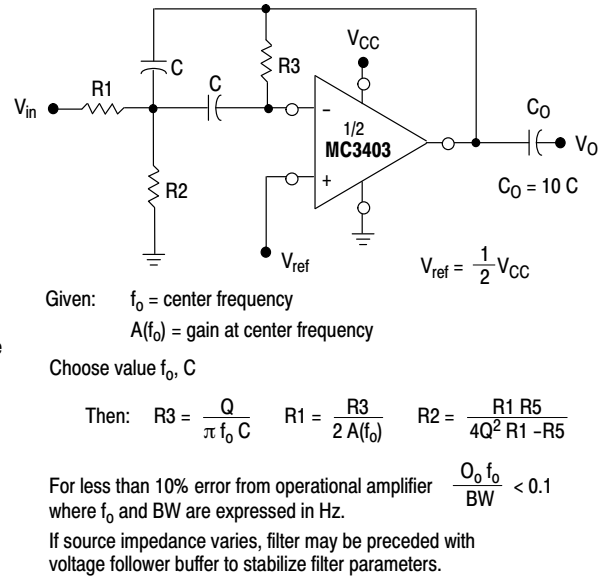

Figure 15. Multiple Feedback Bandpass Filter

MC3403, MC3303**ORDERING INFORMATION**

Device	Package	Shipping†
MC3303DR2G	SOIC-14 (Pb-Free)	2,500 Tape & Reel
MC3403DR2G	SOIC-14 (Pb-Free)	2,500 Tape & Reel

DISCONTINUED (Note 6)

MC3303D	SOIC-14	55 Units / Rail
MC3303DG	SOIC-14 (Pb-Free)	
MC3303DR2	SOIC-14	2,500 Tape & Reel

†For information on tape and reel specifications, including part orientation and tape sizes, please refer to our Tape and Reel Packaging Specifications Brochure, [BRD8011/D](#).

6. **DISCONTINUED:** These devices are not recommended for new design. Please contact your **onsemi** representative for information. The most current information on these devices may be available on www.onsemi.com.



**MECHANICAL CASE OUTLINE
PACKAGE DIMENSIONS**

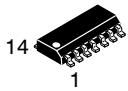

SCALE 1:1

SOIC-14 NB
CASE 751A-03
ISSUE L

DATE 03 FEB 2016

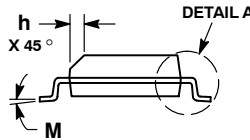
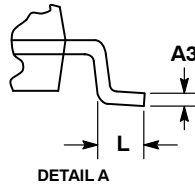
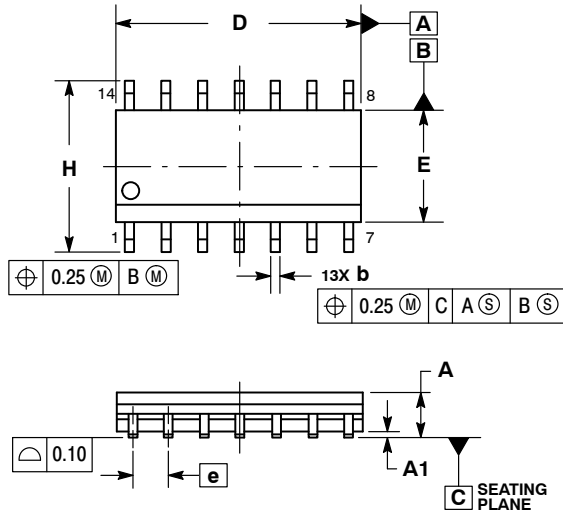

NOTES:

1. DIMENSIONING AND TOLERANCING PER ASME Y14.5M, 1994.
2. CONTROLLING DIMENSION: MILLIMETERS.
3. DIMENSION b DOES NOT INCLUDE DAMBAR PROTRUSION. ALLOWABLE PROTRUSION SHALL BE 0.13 TOTAL IN EXCESS OF AT MAXIMUM MATERIAL CONDITION.
4. DIMENSIONS D AND E DO NOT INCLUDE MOLD PROTRUSIONS.
5. MAXIMUM MOLD PROTRUSION 0.15 PER SIDE.

DIM	MILLIMETERS		INCHES	
	MIN	MAX	MIN	MAX
A	1.35	1.75	0.054	0.068
A1	0.10	0.25	0.004	0.010
A3	0.19	0.25	0.008	0.010
b	0.35	0.49	0.014	0.019
D	8.55	8.75	0.337	0.344
E	3.80	4.00	0.150	0.157
e	1.27 BSC		0.050 BSC	
H	5.80	6.20	0.228	0.244
h	0.25	0.50	0.010	0.019
L	0.40	1.25	0.016	0.049
M	0°	7°	0°	7°

SOLDERING FOOTPRINT*

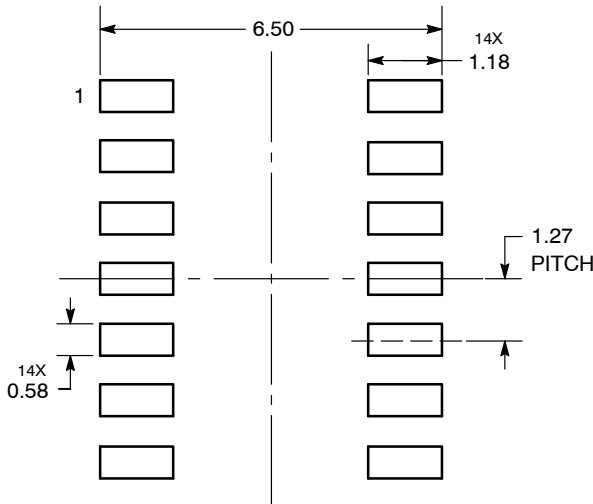

DIMENSIONS: MILLIMETERS

*For additional information on our Pb-Free strategy and soldering details, please download the onsemi Soldering and Mounting Techniques Reference Manual, SOLDERRM/D.

GENERIC MARKING DIAGRAM*

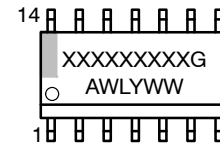

- XXXXXX = Specific Device Code
- A = Assembly Location
- WL = Wafer Lot
- Y = Year
- WW = Work Week
- G = Pb-Free Package

*This information is generic. Please refer to device data sheet for actual part marking. Pb-Free indicator, "G" or microdot "▪", may or may not be present. Some products may not follow the Generic Marking.

STYLES ON PAGE 2

DOCUMENT NUMBER:	98ASB42565B	Electronic versions are uncontrolled except when accessed directly from the Document Repository. Printed versions are uncontrolled except when stamped "CONTROLLED COPY" in red.
DESCRIPTION:	SOIC-14 NB	PAGE 1 OF 2

onsemi and onsemi are trademarks of Semiconductor Components Industries, LLC dba onsemi or its subsidiaries in the United States and/or other countries. onsemi reserves the right to make changes without further notice to any products herein. onsemi makes no warranty, representation or guarantee regarding the suitability of its products for any particular purpose, nor does onsemi assume any liability arising out of the application or use of any product or circuit, and specifically disclaims any and all liability, including without limitation special, consequential or incidental damages. onsemi does not convey any license under its patent rights nor the rights of others.

SOIC-14
CASE 751A-03
ISSUE L

DATE 03 FEB 2016

STYLE 1:
 PIN 1. COMMON CATHODE
 2. ANODE/CATHODE
 3. ANODE/CATHODE
 4. NO CONNECTION
 5. ANODE/CATHODE
 6. NO CONNECTION
 7. ANODE/CATHODE
 8. ANODE/CATHODE
 9. ANODE/CATHODE
 10. NO CONNECTION
 11. ANODE/CATHODE
 12. ANODE/CATHODE
 13. NO CONNECTION
 14. COMMON ANODE

STYLE 2:
 CANCELLED

STYLE 3:
 PIN 1. NO CONNECTION
 2. ANODE
 3. ANODE
 4. NO CONNECTION
 5. ANODE
 6. NO CONNECTION
 7. ANODE
 8. ANODE
 9. ANODE
 10. NO CONNECTION
 11. ANODE
 12. ANODE
 13. NO CONNECTION
 14. COMMON CATHODE

STYLE 4:
 PIN 1. NO CONNECTION
 2. CATHODE
 3. CATHODE
 4. NO CONNECTION
 5. CATHODE
 6. NO CONNECTION
 7. CATHODE
 8. CATHODE
 9. CATHODE
 10. NO CONNECTION
 11. CATHODE
 12. CATHODE
 13. NO CONNECTION
 14. COMMON ANODE

STYLE 5:
 PIN 1. COMMON CATHODE
 2. ANODE/CATHODE
 3. ANODE/CATHODE
 4. ANODE/CATHODE
 5. ANODE/CATHODE
 6. NO CONNECTION
 7. COMMON ANODE
 8. COMMON CATHODE
 9. ANODE/CATHODE
 10. ANODE/CATHODE
 11. ANODE/CATHODE
 12. ANODE/CATHODE
 13. NO CONNECTION
 14. COMMON ANODE

STYLE 6:
 PIN 1. CATHODE
 2. CATHODE
 3. CATHODE
 4. CATHODE
 5. CATHODE
 6. CATHODE
 7. CATHODE
 8. ANODE
 9. ANODE
 10. ANODE
 11. ANODE
 12. ANODE
 13. ANODE
 14. ANODE

STYLE 7:
 PIN 1. ANODE/CATHODE
 2. COMMON ANODE
 3. COMMON CATHODE
 4. ANODE/CATHODE
 5. ANODE/CATHODE
 6. ANODE/CATHODE
 7. ANODE/CATHODE
 8. ANODE/CATHODE
 9. ANODE/CATHODE
 10. ANODE/CATHODE
 11. COMMON CATHODE
 12. COMMON ANODE
 13. ANODE/CATHODE
 14. ANODE/CATHODE

STYLE 8:
 PIN 1. COMMON CATHODE
 2. ANODE/CATHODE
 3. ANODE/CATHODE
 4. NO CONNECTION
 5. ANODE/CATHODE
 6. ANODE/CATHODE
 7. COMMON ANODE
 8. COMMON ANODE
 9. ANODE/CATHODE
 10. ANODE/CATHODE
 11. NO CONNECTION
 12. ANODE/CATHODE
 13. ANODE/CATHODE
 14. COMMON CATHODE

DOCUMENT NUMBER:	98ASB42565B	Electronic versions are uncontrolled except when accessed directly from the Document Repository. Printed versions are uncontrolled except when stamped "CONTROLLED COPY" in red.
DESCRIPTION:	SOIC-14 NB	PAGE 2 OF 2

onsemi and **ONSEMI** are trademarks of Semiconductor Components Industries, LLC dba **onsemi** or its subsidiaries in the United States and/or other countries. **onsemi** reserves the right to make changes without further notice to any products herein. **onsemi** makes no warranty, representation or guarantee regarding the suitability of its products for any particular purpose, nor does **onsemi** assume any liability arising out of the application or use of any product or circuit, and specifically disclaims any and all liability, including without limitation special, consequential or incidental damages. **onsemi** does not convey any license under its patent rights nor the rights of others.

onsemi, **Onsemi**, and other names, marks, and brands are registered and/or common law trademarks of Semiconductor Components Industries, LLC dba "**onsemi**" or its affiliates and/or subsidiaries in the United States and/or other countries. **onsemi** owns the rights to a number of patents, trademarks, copyrights, trade secrets, and other intellectual property. A listing of **onsemi**'s product/patent coverage may be accessed at www.onsemi.com/site/pdf/Patent-Marking.pdf. **onsemi** reserves the right to make changes at any time to any products or information herein, without notice. The information herein is provided "as-is" and **onsemi** makes no warranty, representation or guarantee regarding the accuracy of the information, product features, availability, functionality, or suitability of its products for any particular purpose, nor does **onsemi** assume any liability arising out of the application or use of any product or circuit, and specifically disclaims any and all liability, including without limitation special, consequential or incidental damages. Buyer is responsible for its products and applications using **onsemi** products, including compliance with all laws, regulations and safety requirements or standards, regardless of any support or applications information provided by **onsemi**. "Typical" parameters which may be provided in **onsemi** data sheets and/or specifications can and do vary in different applications and actual performance may vary over time. All operating parameters, including "Typicals" must be validated for each customer application by customer's technical experts. **onsemi** does not convey any license under any of its intellectual property rights nor the rights of others. **onsemi** products are not designed, intended, or authorized for use as a critical component in life support systems or any FDA Class 3 medical devices or medical devices with a same or similar classification in a foreign jurisdiction or any devices intended for implantation in the human body. Should Buyer purchase or use **onsemi** products for any such unintended or unauthorized application, Buyer shall indemnify and hold **onsemi** and its officers, employees, subsidiaries, affiliates, and distributors harmless against all claims, costs, damages, and expenses, and reasonable attorney fees arising out of, directly or indirectly, any claim of personal injury or death associated with such unintended or unauthorized use, even if such claim alleges that **onsemi** was negligent regarding the design or manufacture of the part. **onsemi** is an Equal Opportunity/Affirmative Action Employer. This literature is subject to all applicable copyright laws and is not for resale in any manner.

ADDITIONAL INFORMATION

TECHNICAL PUBLICATIONS:

Technical Library: www.onsemi.com/design/resources/technical-documentation
onsemi Website: www.onsemi.com

ONLINE SUPPORT: www.onsemi.com/support

For additional information, please contact your local Sales Representative at www.onsemi.com/support/sales

OUR CERTIFICATE

DiGi provide top-quality products and perfect service for customer worldwide through standardization, technological innovation and continuous improvement. DiGi through third-party certification, we stricly control the quality of products and services. Welcome your RFQ to

Email: Info@DiGi-Electronics.com



Tel: +00 852-30501935

RFQ Email: Info@DiGi-Electronics.com

DiGi is a global authorized distributor of electronic components.