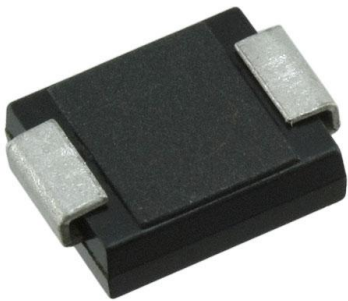


# SS39 Datasheet

[www.digi-electronics.com](http://www.digi-electronics.com)



<https://www.DiGi-Electronics.com>

DiGi Electronics Part Number	SS39-DG
Manufacturer	<a href="#">onsemi</a>
Manufacturer Product Number	SS39
Description	DIODE SCHOTTKY 90V 3A SMC
Detailed Description	Diode 90 V 3A Surface Mount SMC (DO-214AB)

This model SS39 is available at DiGi Electronics.

DiGi Electronics offers a global database of semiconductor and electronic component datasheets.

We welcome your inquiries regarding pricing, lead time, or other product-related questions.

 [Request a Quote](#)

 [Datasheet Search](#)



Tel: +00 852-30501935

RFQ Email: [Info@DiGi-Electronics.com](mailto:Info@DiGi-Electronics.com)

DiGi is a global authorized distributor of electronic components.

## Purchase and inquiry

Manufacturer Product Number:

SS39

Series:

-

Technology:

Schottky

Current - Average Rectified (Io):

3A

Speed:

Fast Recovery =< 500ns, > 200mA (Io)

Capacitance @ Vr, F:

-

Package / Case:

DO-214AB, SMC

Operating Temperature - Junction:

-55°C ~ 150°C

Manufacturer:

onsemi

Product Status:

Not For New Designs

Voltage - DC Reverse (Vr) (Max):

90 V

Voltage - Forward (Vf) (Max) @ If:

850 mV @ 3 A

Current - Reverse Leakage @ Vr:

500 µA @ 90 V

Mounting Type:

Surface Mount

Supplier Device Package:

SMC (DO-214AB)

Base Product Number:

SS39

## Environmental & Export classification

RoHS Status:

ROHS3 Compliant

REACH Status:

REACH Unaffected

HTSUS:

8541.10.0080

Moisture Sensitivity Level (MSL):

1 (Unlimited)

ECCN:

EAR99

# Schottky Rectifier

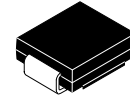
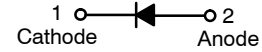
## SS32 - S310

### Description

The SS32–S310 series includes a high–efficiency, low power loss, general–purpose Schottky rectifiers. The clipbonded leg structure provides high thermal performance and low electrical resistance. These rectifiers are suited for free wheeling, secondary rectification, and reverse polarity protection applications.

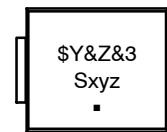
### Features

- Metal to Silicon Rectifiers, Majority Carrier Conduction
- Low–Forward Voltage Drop
- Easy Pick and Place
- High–Surge Current Capability
- This Device is Pb–Free and Halide Free



**SMC**  
**CASE 403AG**

### MARKING DIAGRAM



\$Y	= Logo
&Z	= Assembly Plant Code
&3	= Date Code
Sxyz	= Specific Device Code
	x = S or 3
	y = 1 or 3
	z = 0 or 2–9

### ORDERING INFORMATION

Device	Package	Shipping <sup>†</sup>
SS32 SS33 SS34 SS35 SS36 SS38 SS39 S310	SMC (Pb–Free, Halide–Free)	3000 / Tape & Reel

<sup>†</sup>For information on tape and reel specifications, including part orientation and tape sizes, please refer to our Tape and Reel Packaging Specification Brochure, BRD8011/D.

**SS32 – S310****ABSOLUTE MAXIMUM RATINGS** Values are at  $T_A = 25^\circ\text{C}$  unless otherwise noted.

Symbol	Parameter	Value								Units
		SS32	SS33	SS34	SS35	SS36	SS38	SS39	S310	
$V_{RRM}$	Maximum Repetitive Reverse Voltage	20	30	40	50	60	80	90	100	V
$I_{F(AV)}$	Maximum Average Forward Current at $T_A = 75^\circ\text{C}$	3.0								A
$I_{FSM}$	Non–Repetitive Peak Forward Surge Current: 8.3 ms Single Half–Sine Wave	100								A
$dV/dt$	Maximum Voltage Rate of Change	10000								V/ $\mu\text{s}$
$T_{STG}$	Storage Temperature Range	–55 to +150								$^\circ\text{C}$
$T_J$	Operating Junction Temperature	–55 to +150								$^\circ\text{C}$

Stresses exceeding those listed in the Maximum Ratings table may damage the device. If any of these limits are exceeded, device functionality should not be assumed, damage may occur and reliability may be affected.

**THERMAL CHARACTERISTICS**

Symbol	Parameter	Value	Unit
$P_D$	Power Dissipation	2.27	W
$R_{\theta JA}$	Thermal Resistance, Junction to Ambient (Note 1)	55	$^\circ\text{C}/\text{W}$
$R_{\theta JL}$	Thermal Resistance, Junction to Lead	17	$^\circ\text{C}/\text{W}$

1. Device mounted on FE–4 PCB 0.55 x 0.55 inch (14 x 14 mm).

**ELECTRICAL CHARACTERISTICS** Values are at  $T_A = 25^\circ\text{C}$  unless otherwise noted.

Symbol	Parameter	Test Conditions	Value							Units
			SS32	SS33	SS34	SS35	SS36	SS38	SS39	
$V_F$	Forwarded Voltage	$I_F = 3.0\text{ A}$	500		750		850			mV
$I_R$	Reverse Current at Rated $V_R$	$T_A = 25^\circ\text{C}$	0.5							mA
		$T_A = 100^\circ\text{C}$	20		10					

Product parametric performance is indicated in the Electrical Characteristics for the listed test conditions, unless otherwise noted. Product performance may not be indicated by the Electrical Characteristics if operated under different conditions.

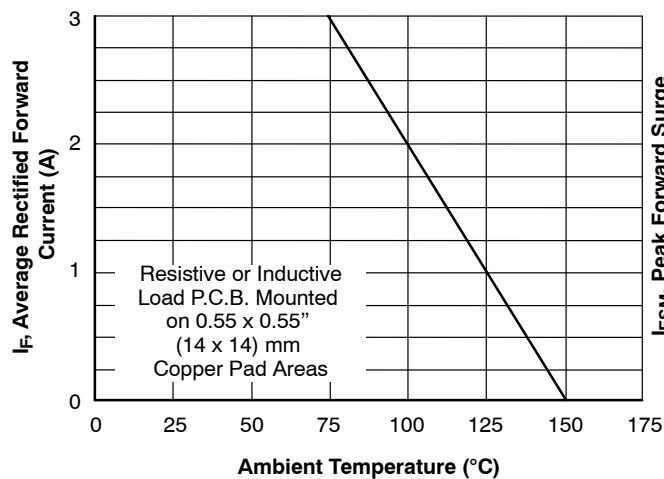
**TYPICAL CHARACTERISTICS**

Figure 1. Forward Current Derating Curve

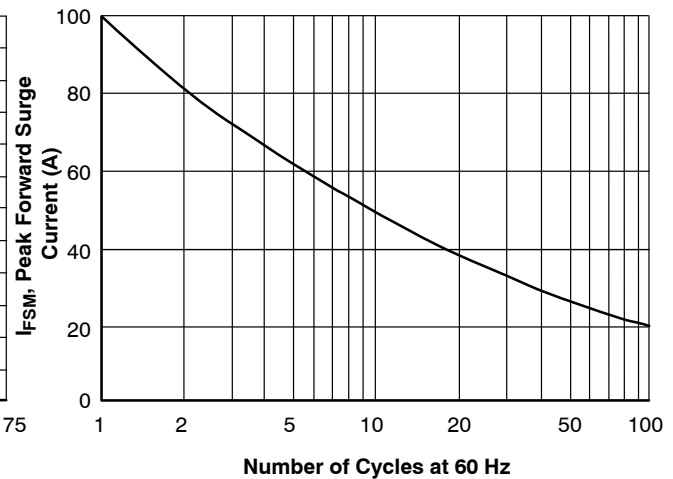


Figure 2. Non–Repetitive Surge Current

## SS32 - S310

### TYPICAL CHARACTERISTICS

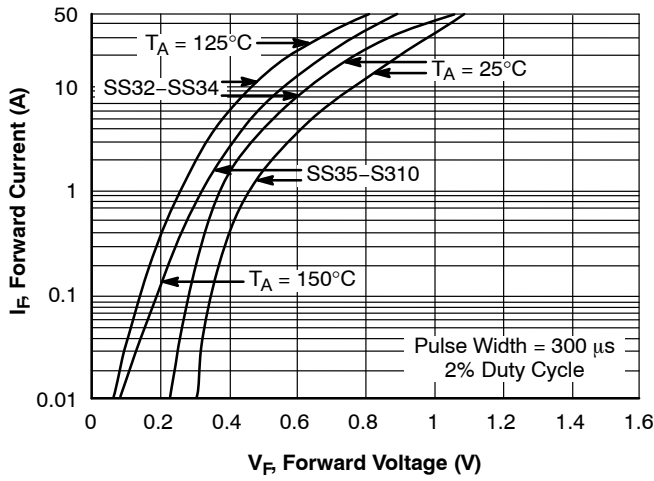


Figure 3. Forward Voltage Characteristics

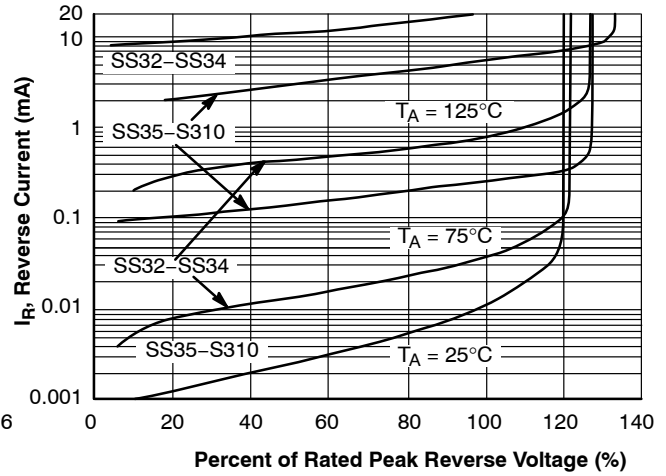


Figure 4. Reverse Current vs. Reverse Voltage

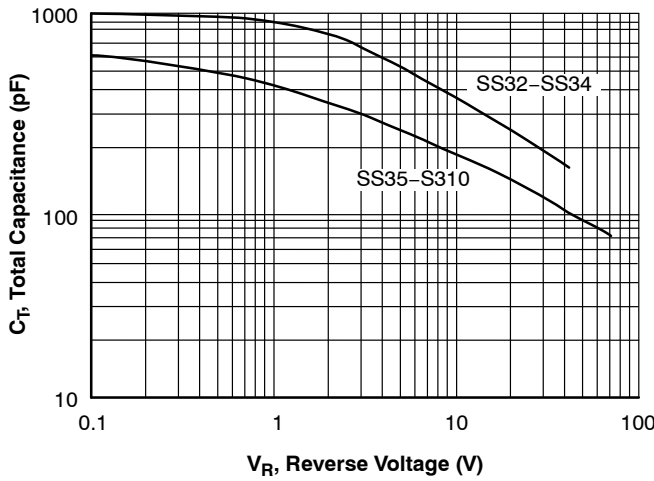


Figure 5. Total Capacitance

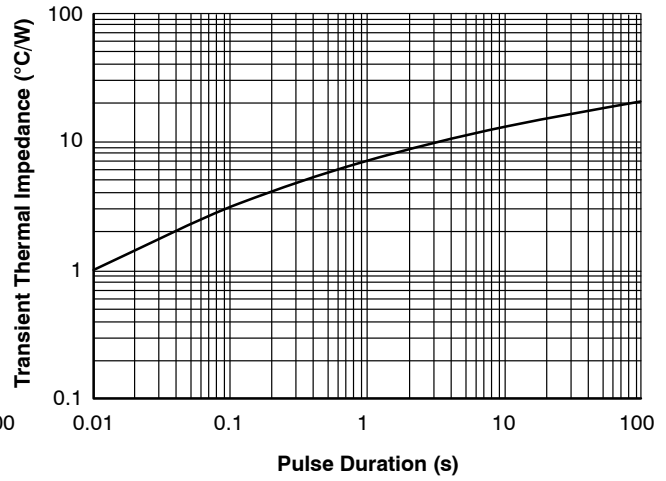
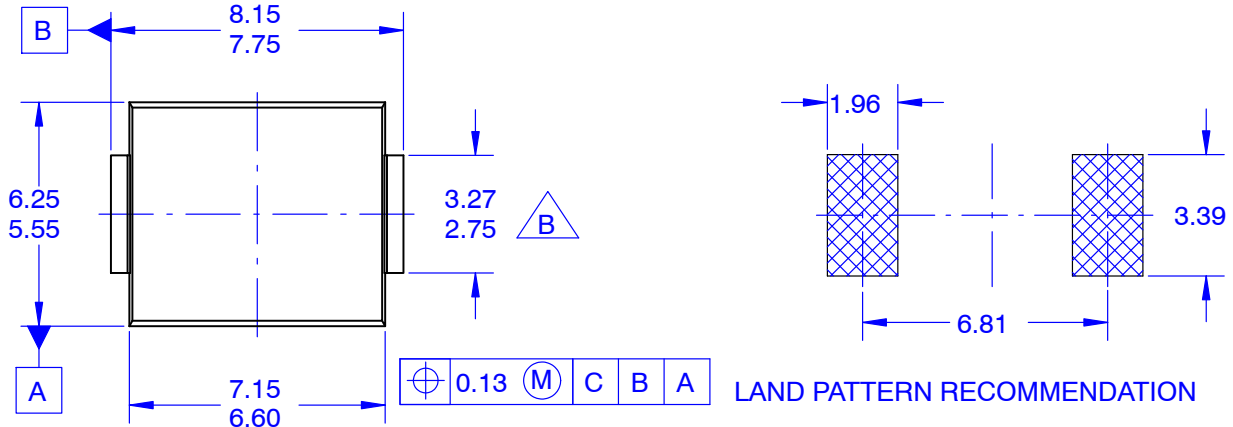


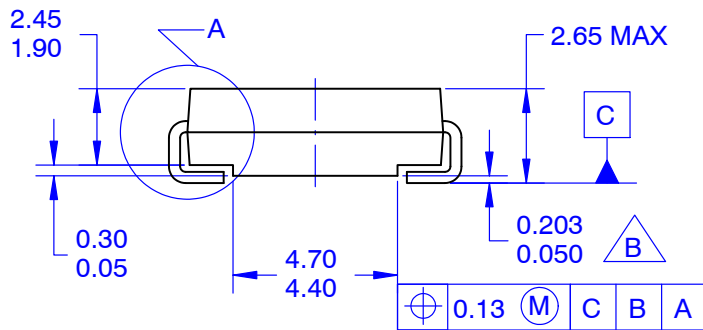
Figure 6. Thermal Impedance Characteristics

**SMC**  
**CASE 403AG**  
**ISSUE O**

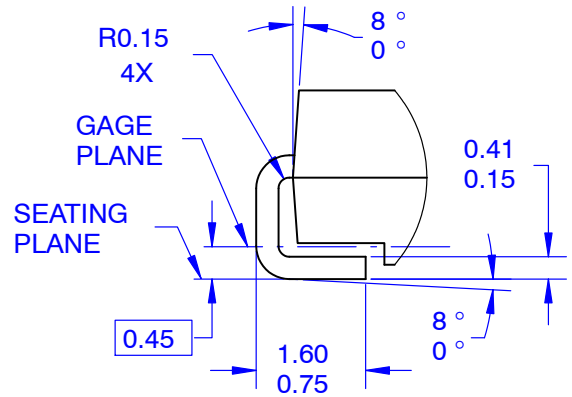
DATE 31 AUG 2016



TOP VIEW



SIDE VIEW



DETAIL A  
SCALE 2:1

NOTES:

A. EXCEPT WHERE NOTED, CONFORMS TO JEDEC DO-214, VARIATION AB

- B** DOES NOT COMPLY TO JEDEC STD. VALUE
- C. ALL DIMENSIONS ARE IN MILLIMETERS
- D. DIMENSIONS ARE EXCLUSIVE OF BURRS, MOLD FLASH, AND TIE BAR PROTRUSIONS.
- E. DIMENSIONS AND TOLERANCING AS PER ASME Y14.5-2009
- F. LAND PATTERN STANDARD: DIOM7957X241M

<b>DOCUMENT NUMBER:</b>	<b>98AON13442G</b>	Electronic versions are uncontrolled except when accessed directly from the Document Repository. Printed versions are uncontrolled except when stamped "CONTROLLED COPY" in red.
<b>DESCRIPTION:</b>	<b>SMC</b>	<b>PAGE 1 OF 1</b>

onsemi and ONSEMI are trademarks of Semiconductor Components Industries, LLC dba onsemi or its subsidiaries in the United States and/or other countries. onsemi reserves the right to make changes without further notice to any products herein. onsemi makes no warranty, representation or guarantee regarding the suitability of its products for any particular purpose, nor does onsemi assume any liability arising out of the application or use of any product or circuit, and specifically disclaims any and all liability, including without limitation special, consequential or incidental damages. onsemi does not convey any license under its patent rights nor the rights of others.

**onsemi**, **Onsemi**, and other names, marks, and brands are registered and/or common law trademarks of Semiconductor Components Industries, LLC dba "**onsemi**" or its affiliates and/or subsidiaries in the United States and/or other countries. **onsemi** owns the rights to a number of patents, trademarks, copyrights, trade secrets, and other intellectual property. A listing of **onsemi**'s product/patent coverage may be accessed at [www.onsemi.com/site/pdf/Patent-Marking.pdf](http://www.onsemi.com/site/pdf/Patent-Marking.pdf). **onsemi** reserves the right to make changes at any time to any products or information herein, without notice. The information herein is provided "as-is" and **onsemi** makes no warranty, representation or guarantee regarding the accuracy of the information, product features, availability, functionality, or suitability of its products for any particular purpose, nor does **onsemi** assume any liability arising out of the application or use of any product or circuit, and specifically disclaims any and all liability, including without limitation special, consequential or incidental damages. Buyer is responsible for its products and applications using **onsemi** products, including compliance with all laws, regulations and safety requirements or standards, regardless of any support or applications information provided by **onsemi**. "Typical" parameters which may be provided in **onsemi** data sheets and/or specifications can and do vary in different applications and actual performance may vary over time. All operating parameters, including "Typicals" must be validated for each customer application by customer's technical experts. **onsemi** does not convey any license under any of its intellectual property rights nor the rights of others. **onsemi** products are not designed, intended, or authorized for use as a critical component in life support systems or any FDA Class 3 medical devices or medical devices with a same or similar classification in a foreign jurisdiction or any devices intended for implantation in the human body. Should Buyer purchase or use **onsemi** products for any such unintended or unauthorized application, Buyer shall indemnify and hold **onsemi** and its officers, employees, subsidiaries, affiliates, and distributors harmless against all claims, costs, damages, and expenses, and reasonable attorney fees arising out of, directly or indirectly, any claim of personal injury or death associated with such unintended or unauthorized use, even if such claim alleges that **onsemi** was negligent regarding the design or manufacture of the part. **onsemi** is an Equal Opportunity/Affirmative Action Employer. This literature is subject to all applicable copyright laws and is not for resale in any manner.

#### ADDITIONAL INFORMATION

**TECHNICAL PUBLICATIONS:**

Technical Library: [www.onsemi.com/design/resources/technical-documentation](http://www.onsemi.com/design/resources/technical-documentation)  
onsemi Website: [www.onsemi.com](http://www.onsemi.com)

**ONLINE SUPPORT:** [www.onsemi.com/support](http://www.onsemi.com/support)

For additional information, please contact your local Sales Representative at [www.onsemi.com/support/sales](http://www.onsemi.com/support/sales)

## OUR CERTIFICATE

DiGi provide top-quality products and perfect service for customer worldwide through standardization, technological innovation and continuous improvement. DiGi through third-party certification, we stricly control the quality of products and services. Welcome your RFQ to

Email: [Info@DiGi-Electronics.com](mailto:Info@DiGi-Electronics.com)



Tel: +00 852-30501935

RFQ Email: [Info@DiGi-Electronics.com](mailto:Info@DiGi-Electronics.com)

DiGi is a global authorized distributor of electronic components.