

GL100MN3MP Datasheet



DiGi Electronics Part Number	GL100MN3MP-DG
Manufacturer	Sharp Microelectronics
Manufacturer Product Number	GL100MN3MP
Description	EMITTER IR 940NM 50MA SMD
Detailed Description	Infrared (IR) Emitter 940nm 1.25V 50mA 3mW/sr @ 20mA 18° 2-SMD, No Lead

<https://www.DiGi-Electronics.com>

This model GL100MN3MP is available at DiGi Electronics.

DiGi Electronics offers a global database of semiconductor and electronic component datasheets.

We welcome your inquiries regarding pricing, lead time, or other product-related questions.

 [Request a Quote](#)

 [Datasheet Search](#)



Tel: +00 852-30501935

RFQ Email: Info@DiGi-Electronics.com

DiGi is a global authorized distributor of electronic components.

Purchase and inquiry

Manufacturer Product Number:

GL100MN3MP

Series:

-

Type:

Infrared (IR)

Radiant Intensity (Ie) Min @ If:

3mW/sr @ 20mA

Voltage - Forward (Vf) (Typ):

1.25V

Orientation:

Top View

Mounting Type:

Surface Mount, Right Angle

Manufacturer:

Sharp Microelectronics

Product Status:

Obsolete

Current - DC Forward (If) (Max):

50mA

Wavelength:

940nm

Viewing Angle:

18°

Operating Temperature:

-30°C ~ 85°C (TA)

Package / Case:

2-SMD, No Lead

Environmental & Export classification

Moisture Sensitivity Level (MSL):

1 (Unlimited)

HTSUS:

8541.41.0000

ECCN:

EAR99

GL100MN3MPx

Surface Mount Type, High Power Output Infrared Emitting Diode



■ Features

1. Compact and thin SMD package
2. Top view and side view mountable
3. Plastic mold with resin lens
4. Peak emission wavelength: 940 nm TYP.
5. Narrow directivity angle ($\Delta\theta$: $\pm 9^\circ$ TYP.)
6. High power output (I_E : 6.0 mW/sr TYP.)
7. Lead free and RoHS directive compliant

■ Model Line-up

Model No.	Packaging	Mount Direction
GL100MN3MP	2000 pcs/reel	Side view
GL100MN3MP1	1500 pcs/reel	Top view

■ Agency Approvals/Compliance

1. Compliant with RoHS directive (2002/95/EC)
2. Content information about the six substances specified in "Management Methods for Control of Pollution Caused by Electronic Information Products Regulation" (popular name: China RoHS) (Chinese: 电子信息产品污染控制管理办法); refer to page 6.

■ Applications

1. Office automation equipment
2. Audio visual equipment
3. Home appliances
4. Telecommunication equipment
5. Measuring equipment
6. Tooling machines
7. Computers

Notice The content of data sheet is subject to change without prior notice.
In the absence of confirmation by device specification sheets, SHARP takes no responsibility for any defects that may occur in equipment using any SHARP devices shown in catalogs, data books, etc. Contact SHARP in order to obtain the latest device specification sheets before using any SHARP device.

■ External Dimensions

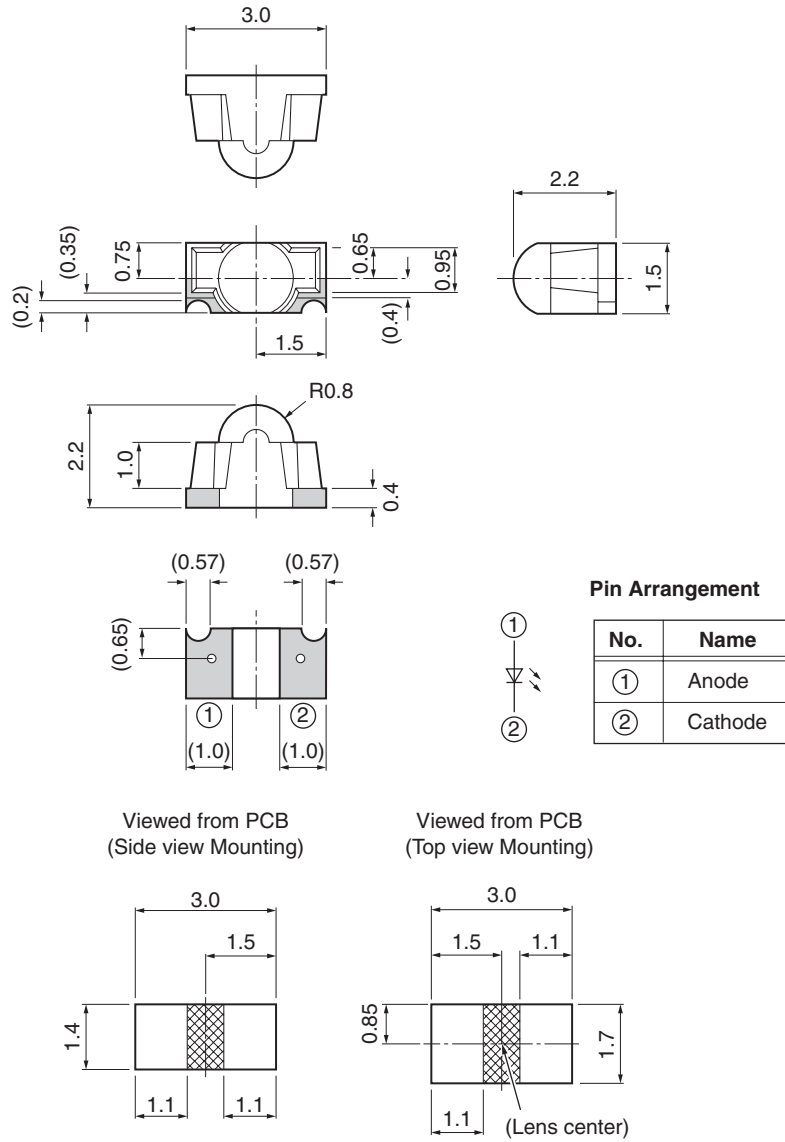

NOTES:

1. Unit: mm
2. Unspecified tolerance : ± 0.2 mm
3. () : Reference dimensions
4. Au-plated area
5. Do not allow circuit runs in area

■ Absolute Maximum Ratings

(Ta = 25°C)

Parameter	Symbol	Rating	Unit
Forward current	I_F	50	mA
Peak pulsed forward current *1	I_{FM}	0.5	A
Reverse voltage	V_R	6	V
Power dissipation	P	75	mW
Operating temperature	Topr	-30 to +85	°C
Storage temperature	Tstg	-40 to +95	°C
Soldering temperature *2	Tsol	240	°C

*1 Pulse width: 100 μ s, Duty ratio: 0.01

*2 10 s (MAX.) see Fig. 4.

■ Electro-optical Characteristics

(Ta = 25°C)

Parameter	Symbol	Conditions	MIN.	TYP.	MAX.	Unit
Forward voltage	V_F	$I_F = 20$ mA	–	1.25	1.5	V
Peak forward voltage	V_{FM}	$I_{FM} = 0.3$ A	–	1.9	3.0	V
Reverse current	I_R	$V_R = 3$ V	–	–	10	μ A
Radiant intensity	I_E	$I_F = 20$ mA	3.0	6.0	12.0	mW/sr
Peak emission wavelength	λ_p	$I_F = 5$ mA	–	940	–	nm
Half width spectrum	$\Delta\lambda$	$I_F = 5$ mA	–	60	–	nm
Terminal capacitance	C_t	$V_R = 0, f = 1$ MHz	–	50	–	pF
Cut-off frequency	f_C	–	–	300	–	kHz
Half-intensity angle	$\Delta\theta$	–	–	± 9	–	degrees

Fig. 1 Forward Current vs. Ambient Temperature

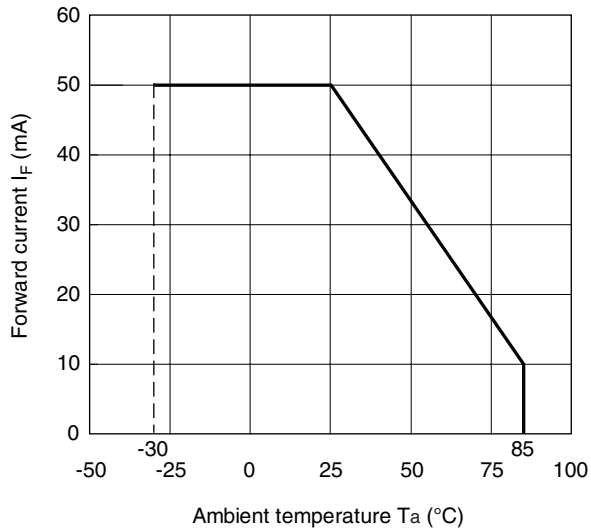

Fig. 3 Peak Forward Current vs. Duty Ratio

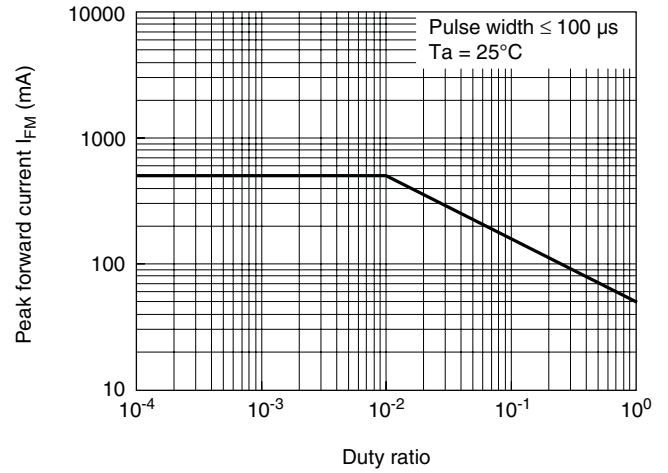
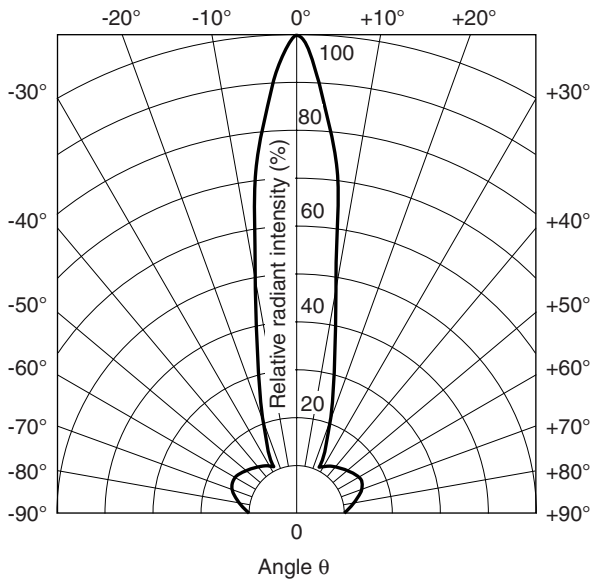

Fig. 2 Radiation Diagram



■ Design Considerations**Design Guidelines**

1. Allow for natural degradation of the LED as a result of long continuous operation. This part will have 50% degradation in output after 5 years of continuous use.
2. This product is not designed to be electromagnetic- and ionized-particle-radiation resistant.

■ Manufacturing Guidelines**Soldering Instructions**

1. Sharp recommends soldering no more than once when using solder reflow methods.
2. When using solder reflow methods, follow reflow soldering temperature profile shown in Fig. 4. Sharp recommends checking the process to make sure these parameters are not exceeded; exceeding these parameters can cause substrate bending or other mechanical stresses leading to debonding of the internal gold wires, or other similar failure modes.
3. If using an infrared lamp to preheat the parts, such heat sources may cause localized high temperatures in the part's resin. Be sure to keep the temperature profile within the guidelines shown in Fig. 4.
4. If hand soldering, use temperatures $\leq 260^\circ$ for ≤ 3 seconds. Do not dip-solder or VPS-solder this part.
5. Do not subject the package to excessive mechanical force during soldering as it may cause deformation or defects in plated connections. Internal connections may be severed due to mechanical force placed on the package due to the PCB flexing during the soldering process.

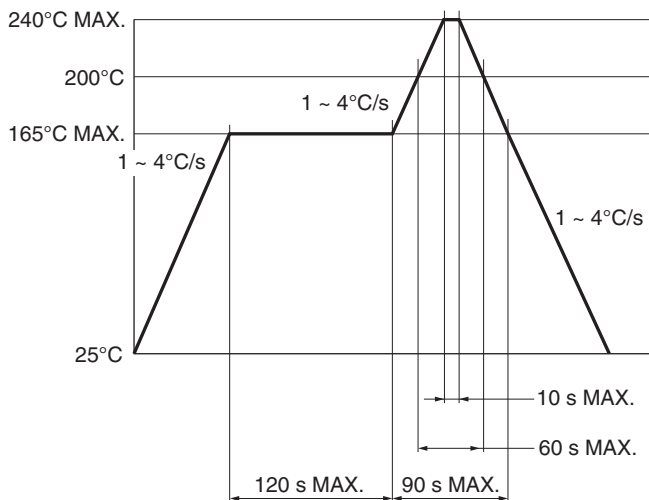
Fig. 4 Reflow Soldering Temperature Profile**Cleaning Instructions**

1. Confirm this device's resistance to process chemicals before use, as certain process chemicals may affect the optical characteristics.
2. Solvent cleaning: Solvent temperature should be 45°C or below. Immersion time should be 3 minutes or less.
3. Ultrasonic cleaning: The effect upon devices varies due to cleaning bath size, ultrasonic power output, cleaning time, PCB size and device mounting circumstances. Sharp recommends testing using actual production conditions to confirm the harmlessness of the ultrasonic cleaning methods.
4. Recommended solvent materials: Ethyl alcohol, Methyl alcohol, and Isopropyl alcohol.

Storage and Handling

1. Store these parts between 5°C and 30°C, at a relative humidity of less than 70%.
2. After breaking the package seal, maintain the environment within 5°C to 25°C, at a relative humidity of less than 60%, and mount the parts within two days. If unable to do so, bake before mounting.
3. When storing the parts after breaking the seal, Sharp recommends storage of no longer than two weeks in a dry box or by resealing the parts in a moisture-proof bag with a desiccant. If unable to do so, bake before mounting.
4. When baking the parts before mounting, Sharp recommends baking the parts only once and only if in a metal tray or mounted on a PCB. Recommended conditions are for 16 to 24 hours, at a temperature of 125°C.

■ Presence of ODCs (RoHS Compliance)

This product shall not contain the following materials, and they are not used in the production process for this product:

- Regulated substances: CFCs, Halon, Carbon tetrachloride, 1,1,1-Trichloroethane (Methylchloroform). Specific brominated flame retardants such as the PBBOs and PBBs are not used in this product at all.

This product shall not contain the following materials banned in the RoHS Directive (2002/95/EC).

- Lead, Mercury, Cadmium, Hexavalent chromium, Polybrominated biphenyls (PBB), Polybrominated diphenyl ethers (PBDE).
- Content information about the six substances specified in “Management Methods for Control of Pollution Caused by Electronic Information Products Regulation” (Chinese: 电子信息产品污染控制管理办法)

Category	Toxic and Hazardous Substances					
	Lead (Pb)	mercury (Hg)	Cadmium (Cd)	Hexavalent chromium (Cr ⁶⁺)	Polybrominated biphenyls (PBB)	Polybrominated diphenyl ethers (PBDE)
Infrared Emitting Diode	✓	✓	✓	✓	✓	✓

NOTE: ✓ indicates that the content of the toxic and hazardous substance in all the homogeneous materials of the part is below the concentration limit requirement as described in SJ/T 11363-2006 standard.

■ Taping Specifications

1. Tape structure and dimensions conforms to those shown in Fig. 5 to Fig. 10.
2. Product insertion will have the cathode to the hole side of the tape.
3. Cover tape peel-separation force: $F = 0.2$ to 1.0 N (where θ 160° to 180°)
4. Quantity per reel = 2000 pcs. (GL100MN3MP) or 1500 pcs. (GL100MN3MP1)
5. Product mass: 0.01 g (approx.)
6. Packaging:
 - a. Reels are sealed inside an aluminum bag, along with a humidity indicator card.
 - b. Bags are labeled and securely packed.

Fig. 7 Product Insertion Direction

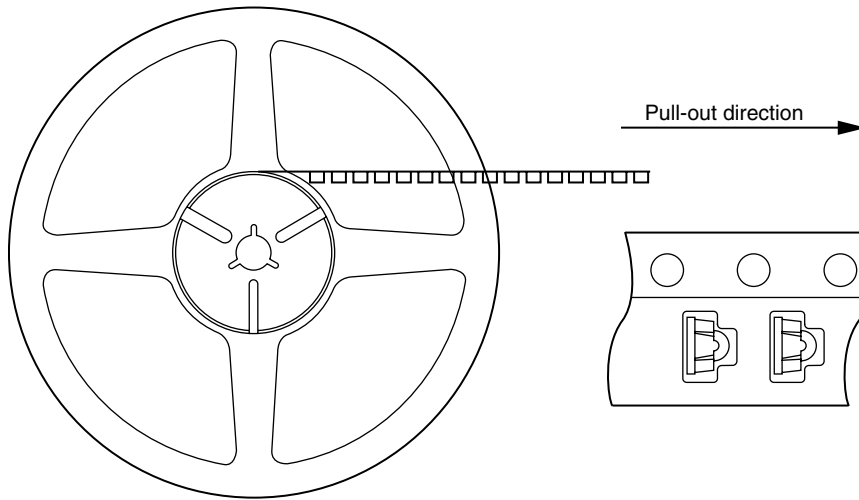

● GL100MN3MP1 (Top view mount, 1500 pcs/reel)

Fig. 8 Tape Shape and Dimension

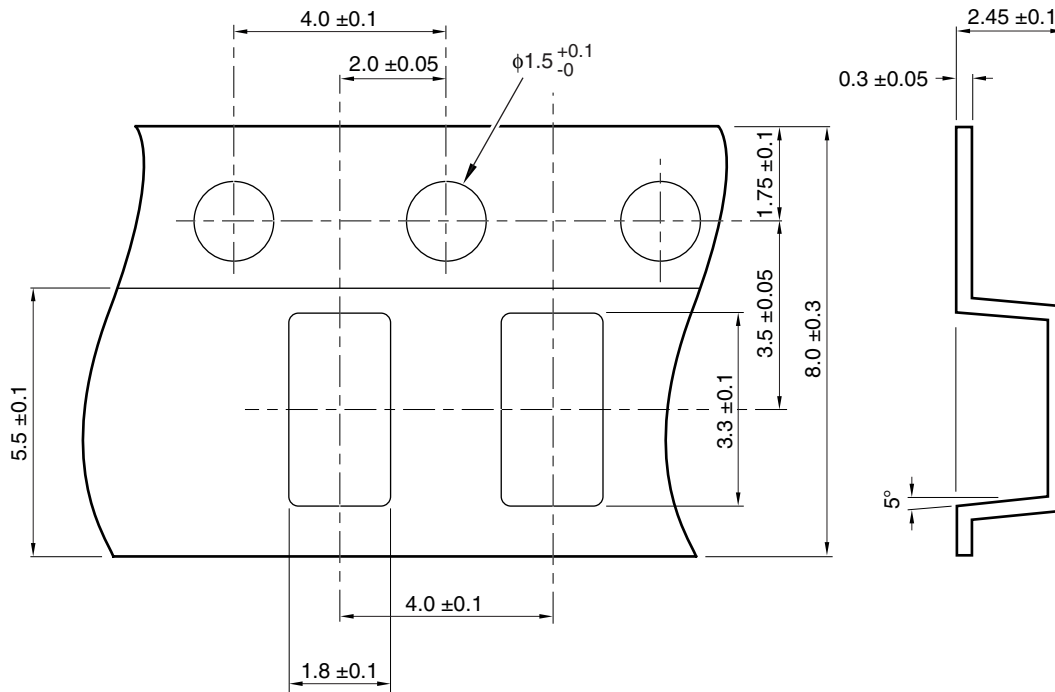
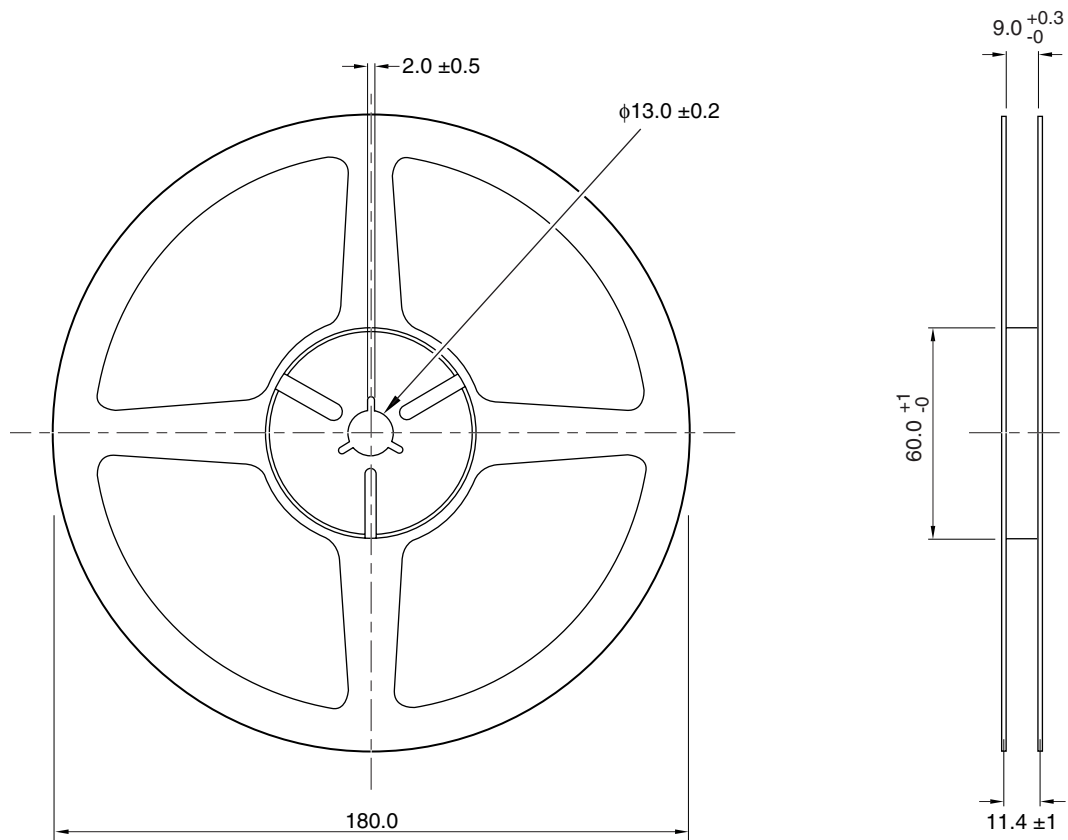
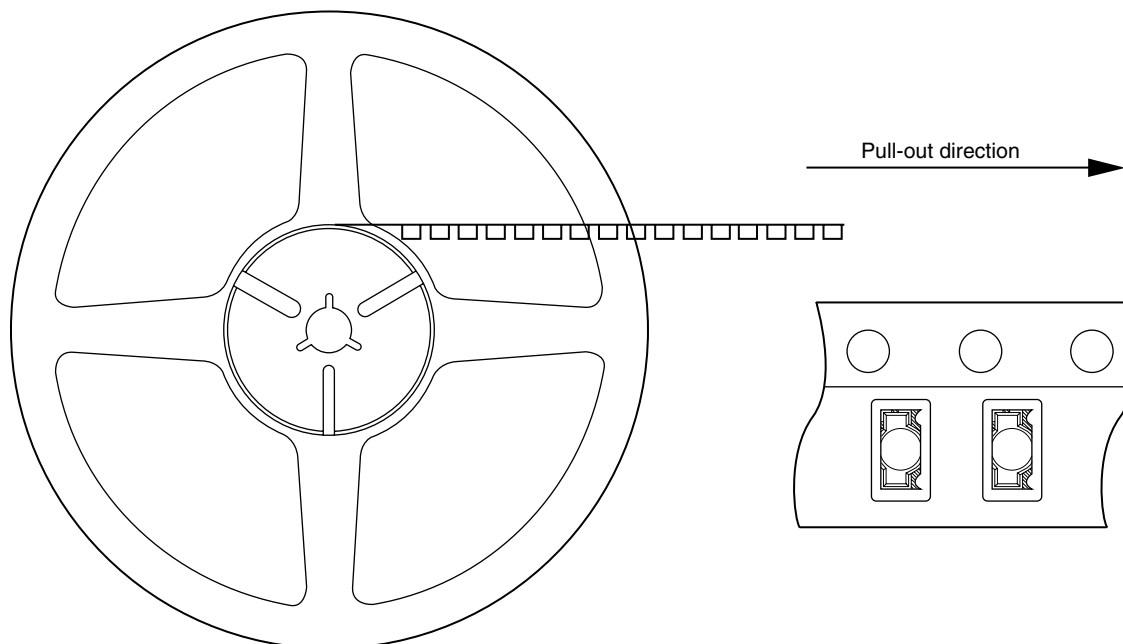

Fig. 9 Reel Shape and Dimension



NOTE: Unit: mm

Fig. 10 Product Insertion Direction



■ Important Notices

· The circuit application examples in this publication are provided to explain representative applications of SHARP devices and are not intended to guarantee any circuit design or license any intellectual property rights. SHARP takes no responsibility for any problems related to any intellectual property right of a third party resulting from the use of SHARP's devices.

· Contact SHARP in order to obtain the latest device specification sheets before using any SHARP device. SHARP reserves the right to make changes in the specifications, characteristics, data materials, structure, and other contents described herein at any time without notice in order to improve design or reliability. Manufacturing locations are also subject to change without notice.

· Observe the following points when using any devices in this publication. SHARP takes no responsibility for damage caused by improper use of the devices which does not meet the conditions and absolute maximum ratings to be used specified in the relevant specification sheet nor meet the following conditions:

(i) The devices in this publication are designed for use in general electronic equipment designs such as:

- Personal computers
- Office automation equipment
- Telecommunication equipment (terminal)
- Test and measurement equipment
- Industrial control
- Audio visual equipment
- Consumer electronics

(ii) Measures such as fail-safe function and redundant design should be taken to ensure reliability and safety when SHARP devices are used for or in connection with equipment that requires higher reliability such as:

- Transportation control and safety equipment (i.e., aircraft, trains, automobiles, etc.)
- Traffic signals
- Gas leakage sensor breakers
- Alarm equipment
- Various safety devices, etc.

(iii) SHARP devices shall not be used for or in connection with equipment that requires an extremely high level of reliability and safety such as:

- Space applications
- Telecommunication equipment (trunk lines)
- Nuclear power control equipment
- Medical and other life support equipment (e.g. scuba)

· If the SHARP devices listed in this publication fall within the scope of strategic products described in the Foreign Exchange and Foreign Trade Law of Japan, it is necessary to obtain approval to export such SHARP devices.

· This publication is the proprietary product of SHARP and is copyrighted, with all rights reserved. Under the copyright laws, no part of this publication may be reproduced or transmitted in any form or by any means, electronic or mechanical, for any purpose, in whole or in part, without the express written permission of SHARP. Express written permission is also required before any use of this publication may be made by a third party.

· Contact and consult with a SHARP representative if there are any questions about the contents of this publication.

OUR CERTIFICATE

DiGi provide top-quality products and perfect service for customer worldwide through standardization, technological innovation and continuous improvement. DiGi through third-party certification, we stricly control the quality of products and services. Welcome your RFQ to

Email: Info@DiGi-Electronics.com



Tel: +00 852-30501935

RFQ Email: Info@DiGi-Electronics.com

DiGi is a global authorized distributor of electronic components.