

# GP1FD210RP Datasheet

ligi-electronics.com



<https://www.DiGi-Electronics.com>

DiGi Electronics Part Number	GP1FD210RP-DG
Manufacturer	<a href="#">Sharp Microelectronics</a>
Manufacturer Product Number	GP1FD210RP
Description	FIBER OPTIC RECEIVER 8MBPS M JK
Detailed Description	Fiber Optic Receiver Digital Audio 8Mbps -24dBm 2 .4V ~ 3V 7.5 mA

This model GP1FD210RP is available at DiGi Electronics.

DiGi Electronics offers a global database of semiconductor and electronic component datasheets.

We welcome your inquiries regarding pricing, lead time, or other product-related questions.

 [Request a Quote](#)

 [Datasheet Search](#)



Tel: +00 852-30501935

RFQ Email: [Info@DiGi-Electronics.com](mailto:Info@DiGi-Electronics.com)

DiGi is a global authorized distributor of electronic components.

## Purchase and inquiry

Manufacturer Product Number:

GP1FD210RP

Series:

-

Data Rate:

8Mbps

Power - Minimum Receivable:

-24dBm

Applications:

Digital Audio

Manufacturer:

Sharp Microelectronics

Product Status:

Obsolete

Voltage - Supply:

2.4V ~ 3V

Current - Supply:

7.5 mA

## Environmental & Export classification

RoHS Status:

RoHS non-compliant

ECCN:

EAR99

Moisture Sensitivity Level (MSL):

3 (168 Hours)

HTSUS:

8541.49.1050

# GP1FD210RP

## Thin Low Voltage Operation Type Optical Mini-jack for Digital Audio Equipment

### ■ Features

1. Thin type (4.2mm) fiber optic receiver
2. Compact (adoption of small jack for mini plug) JIS C6560
3. Both optical and electrical signal can be distinguished and received
4. Low voltage operation ( $V_{CC}$  2.4 to 3.0V)
5. High speed data transmission  
(Signal transmission speed : MAX, 8Mb/s (NRZ signal))

### ■ Applications

1. MD players
2. Portable CD players (Optic receiver part)

### ■ Absolute Maximum Ratings (Photoelectric conversion element) ( $T_a=25^\circ\text{C}$ )

Parameter	Symbol	Rating	Unit
Supply voltage	$V_{CC}$	-0.5 to +7.0	V
Operating temperature	$T_{opr}$	-20 to +70	$^\circ\text{C}$
Storage temperature	$T_{stg}$	-30 to +80	$^\circ\text{C}$
*1 Soldering temperature (Reflow)	$T_{sol}$	240	$^\circ\text{C}$
Output current	$I_{OH}$	2 (source current)	mA
	$I_{OL}$	4 (sink current)	mA

\*1 For 10s (according to reflow profile in the specification sheet)

### ■ Absolute Maximum Ratings (Jack)

Parameter	Symbol	Rating	Unit
Total power dissipation	$P_{tot}$	D.C. 12V, 1A	-
Operating temperature	$T_{opr}$	-20 to +70	$^\circ\text{C}$
Storage temperature	$T_{stg}$	-30 to +80	$^\circ\text{C}$
*1 Soldering temperature	$T_{sol}$	240	$^\circ\text{C}$
*2 Isolation voltage	$V_{iso}$	A.C. 500V <sub>rms</sub>	-

\*2 For 1minute

### ■ Outline Dimensions

(Unit : mm)

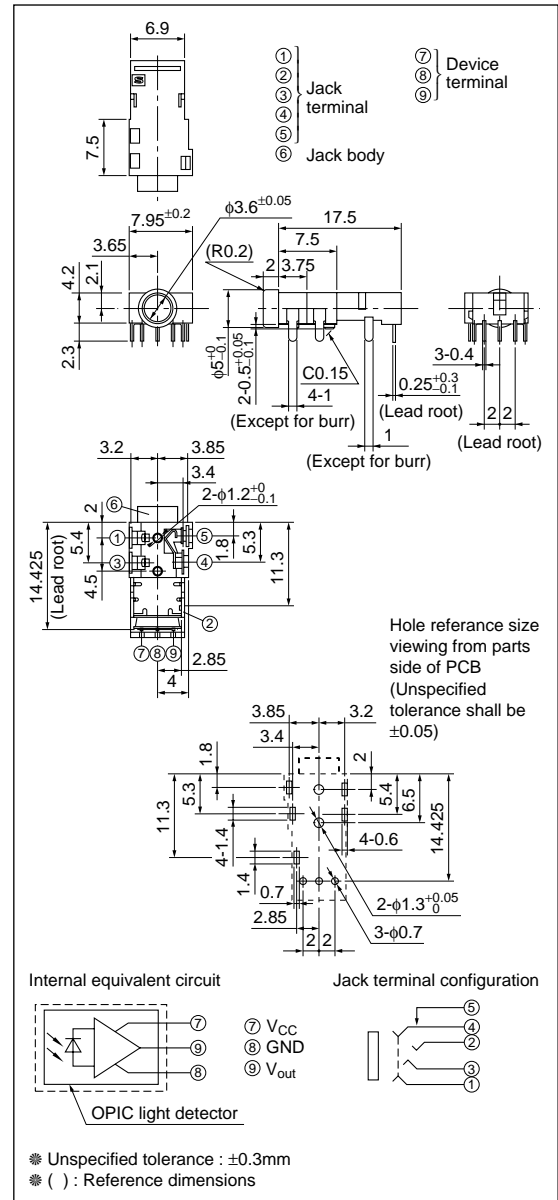

\* "OPIC" (Optical IC) is a trademark of the SHARP Corporation. An OPIC consists of a light-detecting element and signal-processing circuit integrated onto a signal chip.

■ Recommended Operating Conditions

Parameter	Symbol	MIN.	TYP.	MAX.	Unit
Operating supply voltage	V <sub>CC</sub>	2.4	2.5	3.0	V
Operating transfer rate	T	0.1	—	8	Mb/s
Receiver input optical power level	P <sub>C</sub>	-24.0	—	-14.5	dBm

■ Electro-optical Characteristics

(T<sub>a</sub>=25°C, V<sub>CC</sub>=3.0V)

Parameter	Symbol	Conditions	MIN.	TYP.	MAX.	Unit
Peak sensitivity wavelength	λ <sub>p</sub>	—	—	700	—	nm
Dissipation current	I <sub>CC</sub>	Refer to Fig.1	—	5	7.5	mA
High level output voltage	V <sub>OH</sub>	Refer to Fig.2	2.0	2.2	—	V
Low level output voltage	V <sub>OL</sub>	Refer to Fig.2	—	0.2	0.5	V
Rise time	t <sub>r</sub>	Refer to Fig.2	—	17	—	ns
Fall time	t <sub>f</sub>	Refer to Fig.2	—	5	—	ns
Low → High delay time	t <sub>pLH</sub>	Refer to Fig.2	—	—	180	ns
High → Low delay time	t <sub>pHL</sub>	Refer to Fig.2	—	—	180	ns
Pulse width distortion	Δt <sub>w</sub>	Refer to Fig.2	-30	—	+30	ns
Jitter	Δt <sub>j</sub>	Refer to Fig.3, P <sub>C</sub> =-14.5dBm	—	1	30	ns
		Refer to Fig.p3, P <sub>C</sub> =-24dBm	—	—	30	ns

■ Mechanical and Electrical Characteristics(Jack)

Parameter	Symbol	Conditions	MIN.	TYP.	MAX.	Unit
Insertion force, with drawal force	F <sub>p</sub>	*3	5	—	35	N
Contact resistance	R <sub>con</sub>	*4	—	—	30	mΩ
Isolation resistance	R <sub>iso</sub>	D.C. 500V, 1minute	100	—	—	MΩ

Note) This jack is designed for applicable to φ3.5 compact single head plug (JIS C6560)

\*3 Measuring method of insertion force and withdrawal force

Insertion and withdrawal force shall be measured after inserting and withdrawing 3 times by using JIS C6560 standard plug for test

\*4 Measuring method of contact resistance

It measures at 100mA or less and 1 000Hz at the condition of inserting JIS C6560 standard plug for test in which movable contact terminal and make contacts are described

Fig.1 Dissipation Current

Input conditions		Measuring method Measured on an ammeter (DC average amperage)
Supply voltage	V <sub>CC</sub> =2.5V	
Optical output coupling with fiber	P <sub>C</sub> =-14.5dBm	
Standard transmitter input signal	6Mb/s NRZ, Duty 50% or 3Mb/s biphasic mark PRBS signal	

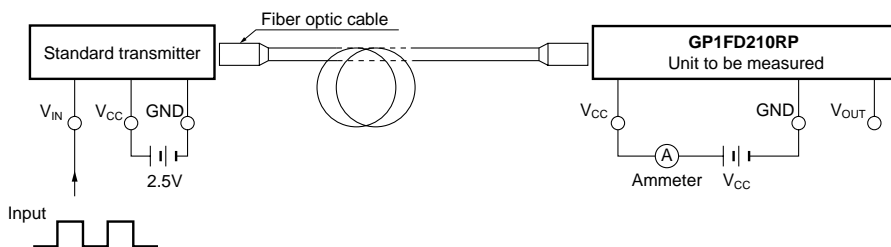
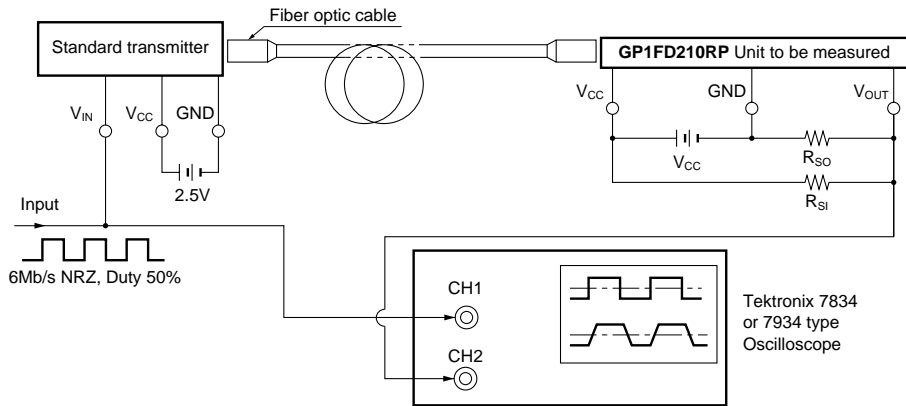

Fig.2 Measuring Method of Output Voltage and Pulse Response



Test item

Test item	Symbol
Low → High pulse delay time	$t_{PLH}$
High → Low pulse delay time	$t_{PHL}$
Rise time	$t_r$
Fall time	$t_f$
Pulse width distortion $\Delta t_w = t_{PHL} - t_{PLH}$	$\Delta t_w$
High level output voltage	$V_{OH}$
Low level output voltage	$V_{OL}$

- Notes (1)  $V_{CC}=2.5V$  (State of operating)  
 (2) The fiber coupling light output set at  $-14.5dBm/-24.0dBm$   
 (3) The probe for the oscilloscope must be more than  $1M\ \Omega$  and less than  $10pF$   
 (4) The output (H/L level) of **GP1FD210RP** are not fixed constantly when it receives the modulating light (including DC light, no input light) less than  $0.1Mb/s$

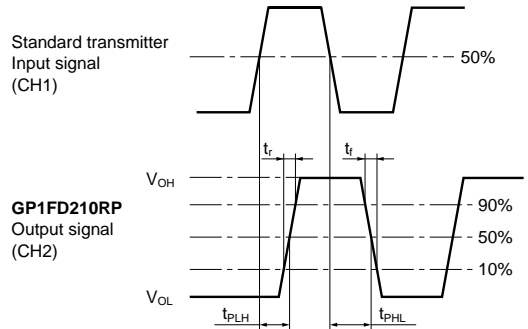
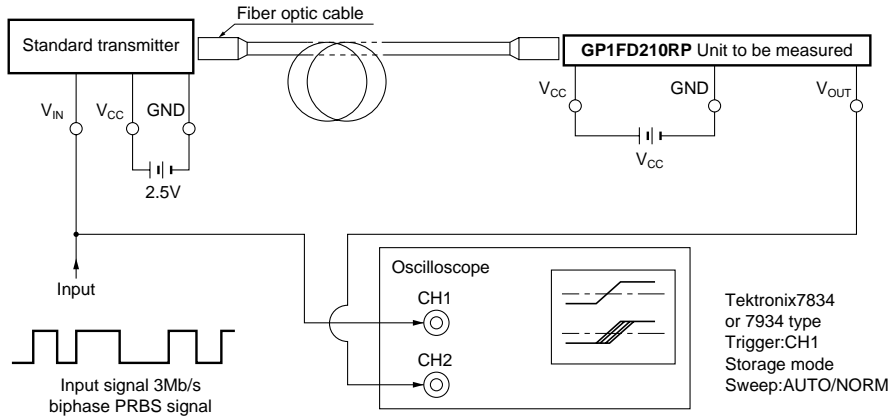

Fig.3 Measuring Method of Jitter



Test item

Test item	Symbol	Test condition
Jitter	$\Delta t_j$	Set the trigger on the rise of input signal to measure the jitter of the rise of output
Jitter	$\Delta t_j$	Set the trigger on the fall of input signal to measure the jitter of the fall of output

- Notes
- (1) The fiber coupling light output set at  $-14.5\text{dBm}/-24.0\text{dBm}$
  - (2) The waveform write time shall be 3 seconds. But do not allow the waveform to be distorted by increasing the brightness too much
  - (3)  $V_{CC}=2.5\text{V}$  (State of operating)
  - (4) The probe for the oscilloscope must be more than  $1\text{M}\Omega$  and less than  $10\text{pF}$

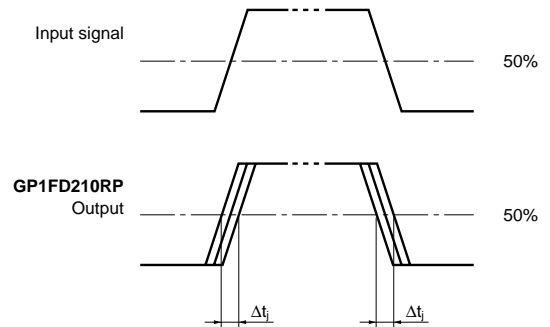

## NOTICE

- The circuit application examples in this publication are provided to explain representative applications of SHARP devices and are not intended to guarantee any circuit design or license any intellectual property rights. SHARP takes no responsibility for any problems related to any intellectual property right of a third party resulting from the use of SHARP's devices.
- Contact SHARP in order to obtain the latest device specification sheets before using any SHARP device. SHARP reserves the right to make changes in the specifications, characteristics, data, materials, structure, and other contents described herein at any time without notice in order to improve design or reliability. Manufacturing locations are also subject to change without notice.
- Observe the following points when using any devices in this publication. SHARP takes no responsibility for damage caused by improper use of the devices which does not meet the conditions and absolute maximum ratings to be used specified in the relevant specification sheet nor meet the following conditions:
  - (i) The devices in this publication are designed for use in general electronic equipment designs such as:
    - Personal computers
    - Office automation equipment
    - Telecommunication equipment [terminal]
    - Test and measurement equipment
    - Industrial control
    - Audio visual equipment
    - Consumer electronics
  - (ii) Measures such as fail-safe function and redundant design should be taken to ensure reliability and safety when SHARP devices are used for or in connection with equipment that requires higher reliability such as:
    - Transportation control and safety equipment (i.e., aircraft, trains, automobiles, etc.)
    - Traffic signals
    - Gas leakage sensor breakers
    - Alarm equipment
    - Various safety devices, etc.
  - (iii) SHARP devices shall not be used for or in connection with equipment that requires an extremely high level of reliability and safety such as:
    - Space applications
    - Telecommunication equipment [trunk lines]
    - Nuclear power control equipment
    - Medical and other life support equipment (e.g., scuba).
- If the SHARP devices listed in this publication fall within the scope of strategic products described in the Foreign Exchange and Foreign Trade Law of Japan, it is necessary to obtain approval to export such SHARP devices.
- This publication is the proprietary product of SHARP and is copyrighted, with all rights reserved. Under the copyright laws, no part of this publication may be reproduced or transmitted in any form or by any means, electronic or mechanical, for any purpose, in whole or in part, without the express written permission of SHARP. Express written permission is also required before any use of this publication may be made by a third party.
- Contact and consult with a SHARP representative if there are any questions about the contents of this publication.

## OUR CERTIFICATE

DiGi provide top-quality products and perfect service for customer worldwide through standardization, technological innovation and continuous improvement. DiGi through third-party certification, we stricly control the quality of products and services. Welcome your RFQ to

Email: [Info@DiGi-Electronics.com](mailto:Info@DiGi-Electronics.com)



Tel: +00 852-30501935

RFQ Email: [Info@DiGi-Electronics.com](mailto:Info@DiGi-Electronics.com)

DiGi is a global authorized distributor of electronic components.