

GP2D150A Datasheet



DiGi Electronics Part Number	GP2D150A-DG
Manufacturer	Sharp Microelectronics
Manufacturer Product Number	GP2D150A
Description	SENSOR OPTICAL 15CM DIGITAL
Detailed Description	Optical Sensor 15cm Digital Output

<https://www.DiGi-Electronics.com>

This model GP2D150A is available at DiGi Electronics.

DiGi Electronics offers a global database of semiconductor and electronic component datasheets.

We welcome your inquiries regarding pricing, lead time, or other product-related questions.

 [Request a Quote](#)

 [Datasheet Search](#)



Tel: +00 852-30501935

RFQ Email: Info@DiGi-Electronics.com

DiGi is a global authorized distributor of electronic components.

Purchase and inquiry

Manufacturer Product Number:

GP2D150A

Series:

-

Sensing Distance:

15cm

Voltage - Supply:

4.5V ~ 5.5V

Voltage - Output Difference (Typ) @ Distance:

-

Operating Temperature:

-10°C ~ 60°C (TA)

Manufacturer:

Sharp Microelectronics

Product Status:

Obsolete

Output Type:

Digital

Current - Supply:

50 mA

Voltage - Output (Typ) @ Distance:

-

Environmental & Export classification

RoHS Status:

RoHS non-compliant

ECCN:

EAR99

Moisture Sensitivity Level (MSL):

1 (Unlimited)

HTSUS:

9031.80.8085

SHARP

GP2D150A

Optoelectronic Device

FEATURES

- Factory set trigger point: 15°
- Digital Output
- Range: 4 to 30 cm
- Typical response time: 39 ms
- Typical start up delay: 46 ms
- Average current consumption: 33 mA

DESCRIPTION

The GP2D150A is a distance measuring sensor with digital output.

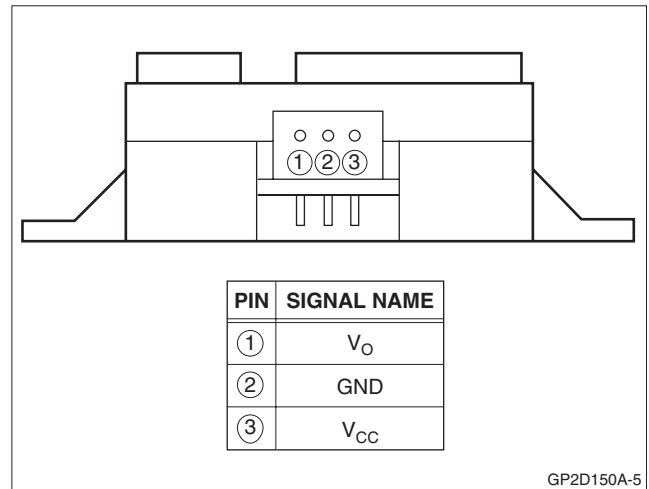
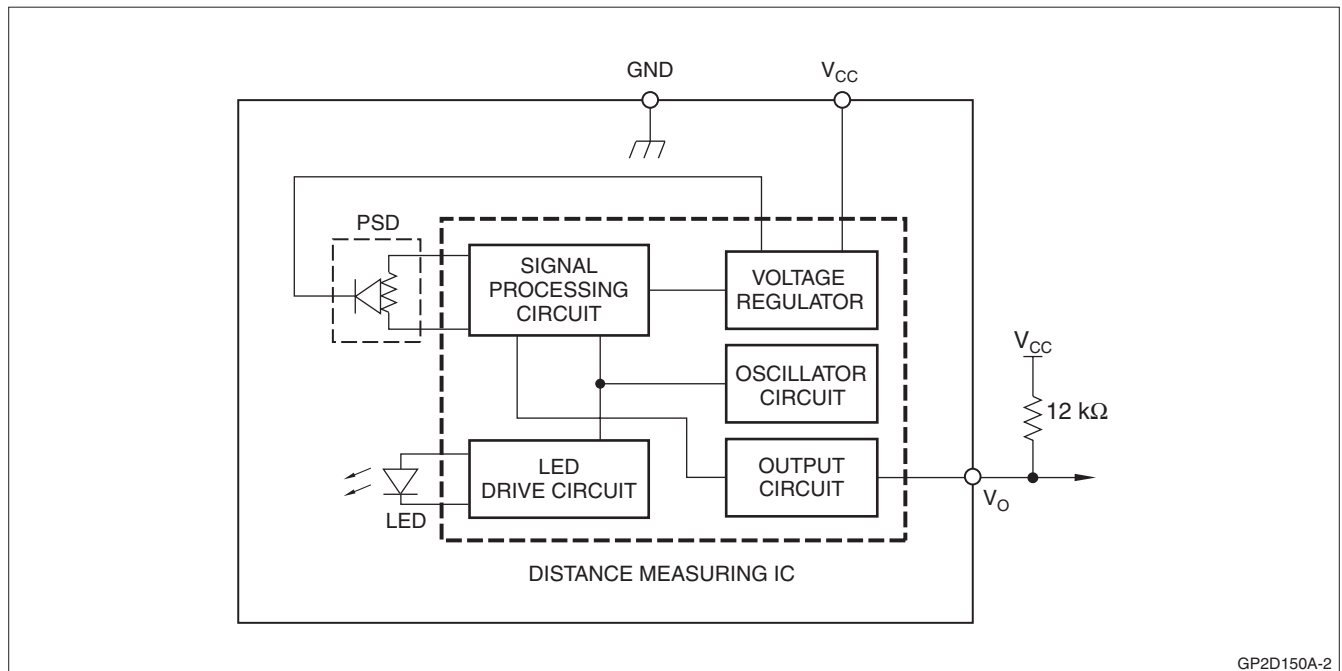
**Figure 1. Pinout****Figure 2. Block Diagram**

ELECTRICAL SPECIFICATIONS

Absolute Maximum Ratings

$T_a = 25^\circ\text{C}$, $V_{CC} = 5\text{ VDC}$

PARAMETER	SYMBOL	RATING	UNIT	REMARKS
Supply Voltage	V_{CC}	-0.3 to +7.0	V	
Output Terminal Voltage	V_O	-0.3 to ($V_{CC} + 0.3$)	V	Open collector output
Operating Temperature	T_{opr}	-10 to +60	$^\circ\text{C}$	
Storage Temperature	T_{stg}	-40 to +70	$^\circ\text{C}$	

Operating Supply Voltage

PARAMETER	SYMBOL	RATING	UNIT
Operating Supply Voltage	V_{CC}	4.5 to 5.5	V

Electro-optical Characteristics

$T_a = 25^\circ\text{C}$, $V_{CC} = 5\text{ VDC}$

PARAMETER	SYMBOL	CONDITIONS	MIN.	TYP.	MAX.	UNIT	NOTES
Measuring Distance Range	ΔL		3	—	30	cm	1, 3
Output Terminal Voltage	V_{OH}	Output voltage at high level	$V_{CC} - 0.3$	—	—	V	1
	V_{OL}	Output voltage at low level	—	—	0.6	V	1
Output Distance Characteristics	V_O		12.5	15	17.5	cm	1, 2, 4
Average Supply Current	I_{CC}		—	33	50	mA	

NOTES:

- Measurements made with Kodak R-27 Gray Card, using the white side, (90% reflectivity).
- Each device is factory set for output switching at $L = 15\text{ cm} \pm 2.5\text{ cm}$.
- Distance measuring range of the sensor optics.
- Output switching has hysteresis. The distance specified by V_O is the distance at which the output switches from LOW to HIGH.
- L = Distance to reflective object.

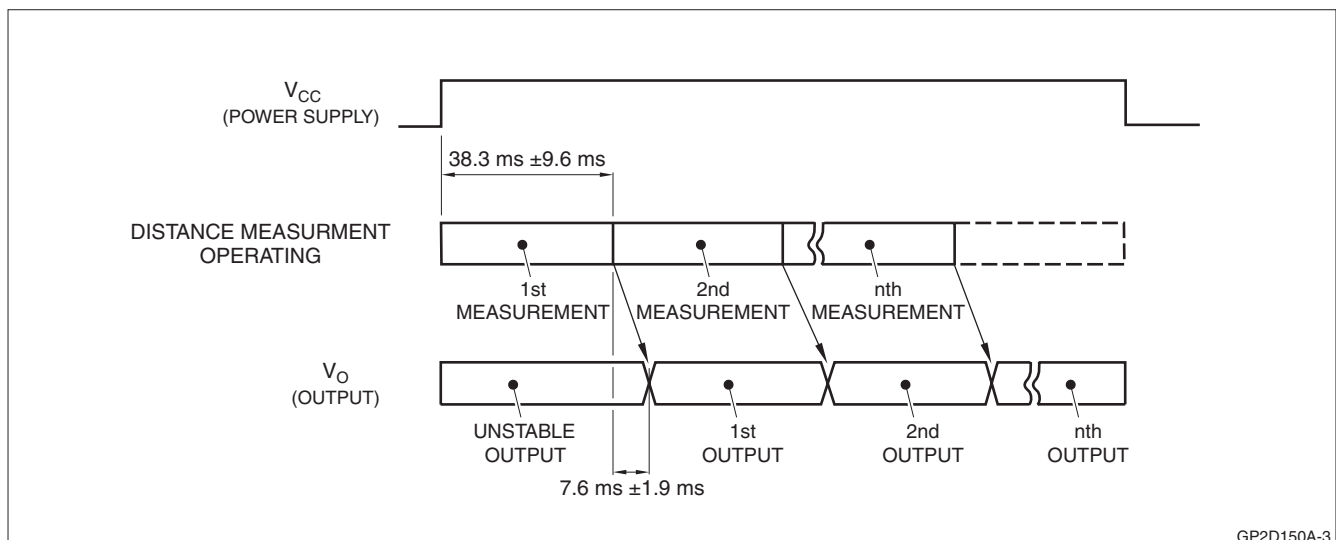

GP2D150A-3

Figure 3. Timing Diagram

RELIABILITY

The reliability of requirements of this device are listed in Table 1.

Table 1. Reliability

TEST ITEMS	TEST CONDITIONS	FAILURE JUDGEMENT CRITERIA	SAMPLES (n), DEFECTIVE (C)
Temperature Cycling	One cycle -40°C (30 min.) to +70°C in 30 minutes, repeated 25 times	Initial $\times 0.8 > V_O$ $V_O > \text{Initial} \times 1.2$	n = 11, C = 0
High Temperature and High Humidity Storage	+40°C, 90% RH, 500h		n = 11, C = 0
High Temperature Storage	+70°C, 500h		n = 11, C = 0
Low Temperature Storage	-40°C, 500h		n = 11, C = 0
Operational Life (High Temperature)	+60°C, $V_{CC} = 5\text{ V}$, 500h		n = 11, C = 0
Mechanical Shock	100 m/s ² , 6.0 ms 3 times/ $\pm X$, $\pm Y$, $\pm Z$ direction		n = 6, C = 0
Variable Frequency Vibration	10-to-55-to-10 Hz in 1 minute Amplitude: 1.5 mm 2h in each X, Y, Z direction		n = 6, C = 0

NOTES:

1. Test conditions are according to Electro-optical Characteristics, shown on page 2.
2. At completion of the test, allow device to remain at nominal room temperature and humidity (non-condensing) for two hours.
3. Confidence level: 90%, Lot Tolerance Percent Defect (LTPD): 20%/40%.

INCOMING INSPECTION

Inspection Lot

Inspection shall be carried out per each delivery lot.

Inspection Method

A single sampling plan, normal inspection level II based on ISO 2859 shall be adopted.

Table 2. Quality Level

DEFECT	INSPECTION ITEM/TEST METHOD	AQL (%)
Major Defect	Electro-optical characteristics defect	0.4
Minor Defect	Defect to appearance or dimensions (crack, split, chip, scratch, stain)*	1.0

NOTE: Any one of these that affects the Electro-optical Characteristics shall be considered a defect.

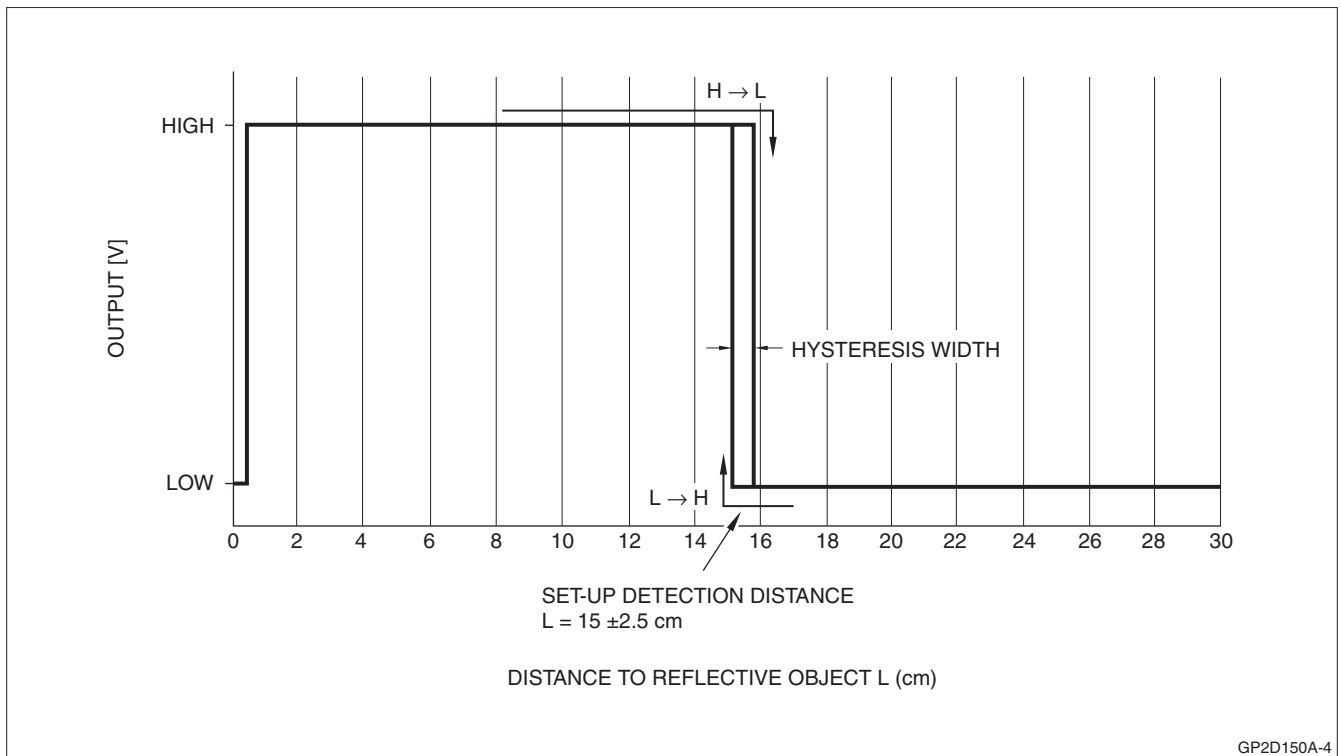
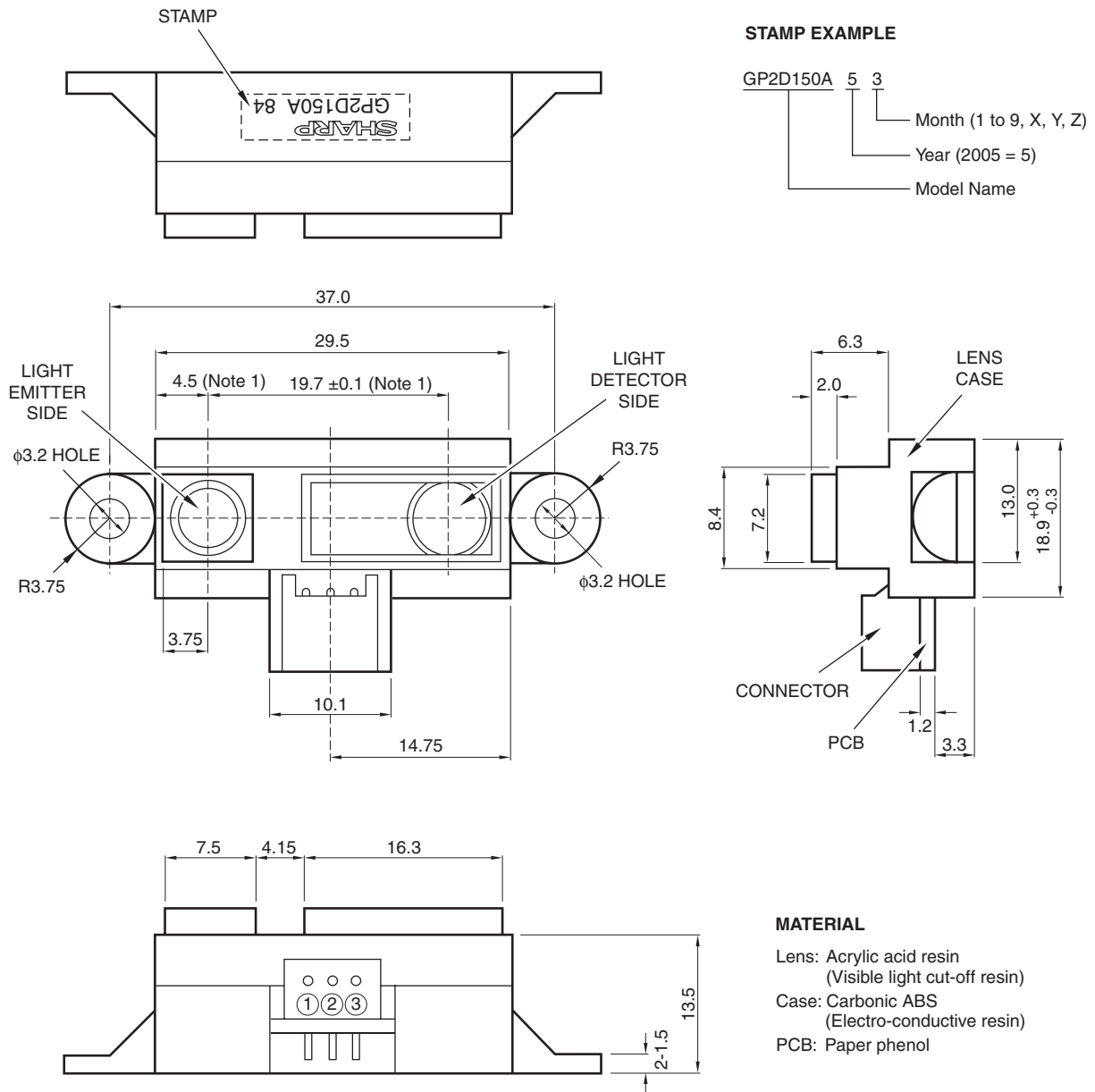

Figure 4. GP2D150A Example of Output Distance Characteristics

PACKAGE SPECIFICATIONS



MATERIAL

Lens: Acrylic acid resin
(Visible light cut-off resin)

Case: Carbonic ABS
(Electro-conductive resin)

PCB: Paper phenol

CONNECTOR SIGNAL

PIN	SIGNAL NAME
①	V _O
②	GND
③	V _{CC}

Connector: J.S.T. Trading Company, LTD
S3B-PH

- NOTES:**
1. Dimensions reference lens center.
 2. Unspecified tolerances are ±0.3 mm.
 3. Dimensions are in mm.

PACKING SPECIFICATION

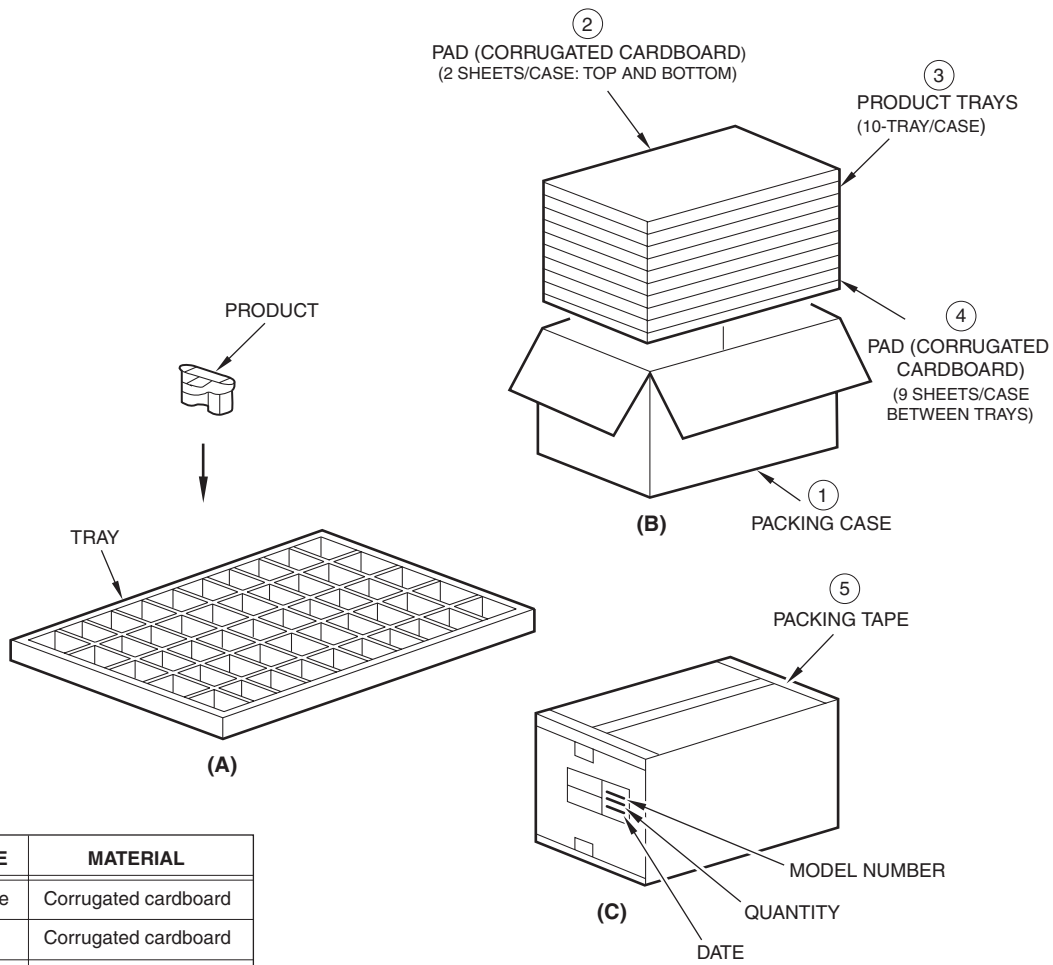

PART NAME	MATERIAL
Packing case	Corrugated cardboard
Pad	Corrugated cardboard
Tray	Polystyrene

PACKING METHOD

- Each tray holds 50 pieces. Packing methods are shown in (A).
- Each box holds 10 trays. Pads are added to top and bottom, and between layers, as in (B). top and bottom. Put pads between each tray (9 pads total) see above drawing (B).
- The box is sealed with packing tape. (C) shows the location of the Model number, Quantity, and Inspection date.
- Package weight: Approximately 4 kg.

GP2D150A-8

NOTES

- Keep the sensor lens clean. Dust, water, oil, and other contaminants can deteriorate the characteristics of this device. Applications should be designed to eliminate sources of lens contamination.
- When using a protective cover over the emitter and detector, ensure the cover efficiently transmits light throughout the wavelength range of the LED ($\lambda = 850 \text{ nm} \pm 70 \text{ nm}$). Both sides of the protective cover should be highly polished. Use of a protective cover may decrease the effective distance over which the sensor operates. Ensure that any cover does not negatively affect the operation over the intended application range.
- Objects in proximity to the sensor may cause reflections that can affect the operation of the sensor.
- Sources of high ambient light (the sun or strong artificial light) may affect measurement. For best results, the application should be designed to prevent interference from direct sunlight or artificial light.
- Using the sensor with a mirror can induce measurement errors. Often, changing the incident angle on the mirror can correct this problem.
- If a prominent boundary line exists in the surface being measured, it should be aligned vertically to avoid measurement error. See Figure 5 for further details.
- When measuring the distance to objects in motion, align the sensor so that the motion is in the horizontal direction instead of vertical. Figure 6 illustrates the preferred alignment.
- A 10 μF (or larger) bypass capacitor between V_{CC} and GND near the sensor is recommended.
- To clean the sensor, use a dry cloth. Use of any liquid to clean the device may result in decreased sensitivity or complete failure.
- Excessive mechanical stress can damage the internal sensor or lens.

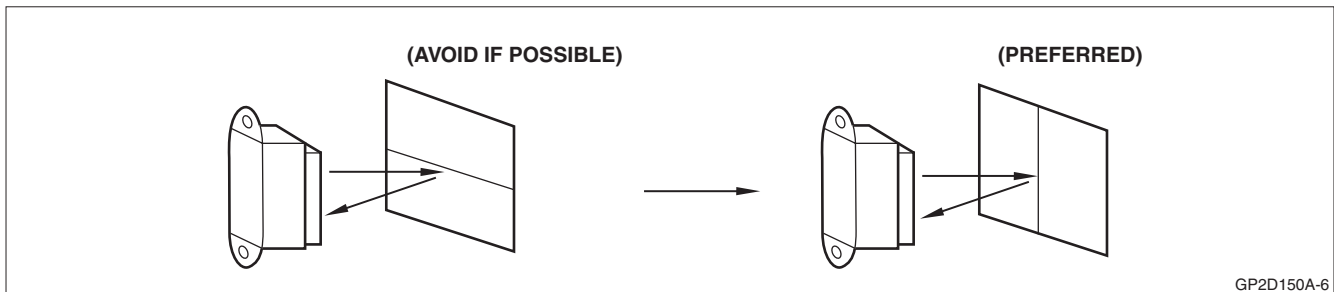

Figure 5. Proper Alignment to Surface Being Measured

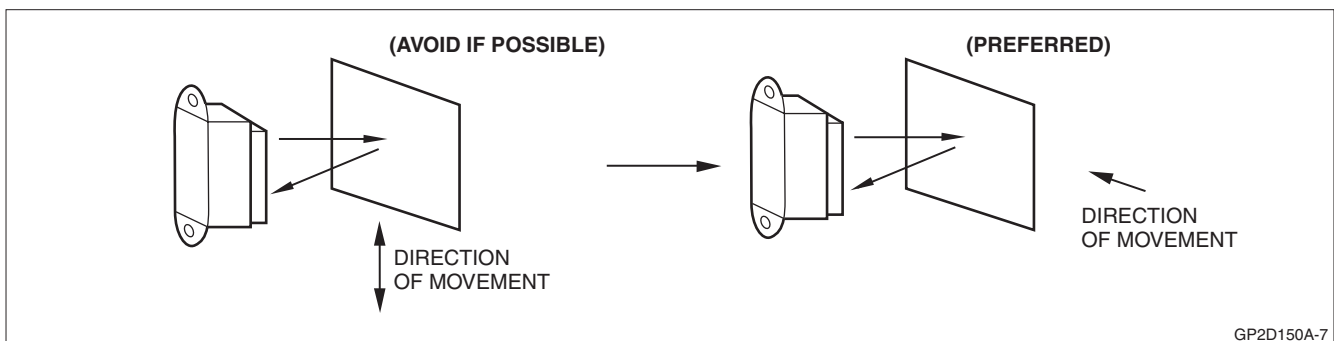

Figure 6. Proper Alignment to Moving Surfaces

NOTICE

The circuit application examples in this publication are provided to explain representative applications of SHARP devices and are not intended to guarantee any circuit design or license any intellectual property right. SHARP takes no responsibility for any problems related to any intellectual property right of a third party resulting from the use of SHARP devices.

SHARP reserves the right to make changes in the specifications, characteristics, data, materials, structures and other contents described herein at any time without notice in order to improve design or reliability.

Contact SHARP in order to obtain the latest device specification sheets before using any SHARP device. Manufacturing locations are also subject to change without notice.

In the absence of confirmation by device specification sheets, SHARP takes no responsibility for any defects that occur in equipment using any SHARP devices shown in catalogs, data books, etc.

The devices listed in this publication are designed for standard applications for use in general electronic equipment. SHARP's devices shall not be used for or in connection with equipment that requires an extremely high level of reliability, such as military and aerospace applications, telecommunication equipment (trunk lines), nuclear power control equipment and medical or other life support equipment (e.g. Scuba). SHARP takes no responsibility for damage caused by improper use of device, which does not meet the conditions for use specified in the relevant specification sheet.

If the SHARP devices listed in the publication fall within the scope of strategic products described in the Foreign Exchange and Foreign Trade Law of Japan, it is necessary to obtain approval to export such SHARP devices.

This publication is the proprietary product of SHARP and is copyrighted, with all rights reserved. Under the copyright laws, no part of this publication may be reproduced or transmitted in any form or by any means, electronic or mechanical for any purpose, in whole or in part, without the express written permission of SHARP. Express written permission is also required before any use of this publication may be made by a third party.

Contact and consult with a SHARP representative if there are any questions about the contents of this publication.

SHARP

SHARP CORPORATION

SALES & MARKETING GROUP

ELECTRONIC COMPONENTS & DEVICES

22-22 NAGAIKE-CHO, ABENO-KU, OSAKA 545-8522, JAPAN

PHONE: (81) 6-6621-1221

FAX: (81) 6117-725300, 6117-725301, 6117-725302

<http://sharp-world.com/products/device>

Specifications are subject to change without notice.

Countries and Areas**U.S.A.**SHARP MICROELECTRONICS
OF THE AMERICAS**North American Head Office**5700 North West Pacific Rim Boulevard
Camas, Washington 98607 USA

PHONE: (1)360-834-2500

FAX: (1)360-834-8903

<http://www.sharpsma.com>**Western Area**1980 Zanker Road, San Jose, CA 95112
PHONE: (1)408-436-4900

FAX: (1)408-436-0924

5901 Bolsa Ave.

Huntington Beach, CA 92647-2053

PHONE: (1)714-903-4600

FAX: (1)714-903-0295

6390 Greenwich Drive, Suite 175

San Diego, CA 92122

PHONE: (1)858-597-0982

FAX: (1)858-597-8701

Central Area

85 W. Algonquin Road, Suite 280

Arlington Heights, IL 60005

PHONE: (1)847-258-2750

FAX: (1)847-439-2479

6303 Commerce Drive, Suite 175 Irving, TX 75063

PHONE: (1)972-582-1710

FAX: (1)972-580-7537

8911 Capitol of Texas Hwy. Suite 3130

Austin, TX 78759

PHONE: (1)512-349-7262

FAX: (1)512-349-7002

20333 State Hwy. 249, Suite 200 Houston, TX 77070

PHONE: (1)281-378-1520

FAX: (1)281-378-1521

W129 S 9647 Tony Lema Lane Muskego, WI 53150

PHONE: (1)414-529-9568

FAX: (1)414-529-9569

3001 West Big Beaver Road, Suite 722

Troy, MI 48084

PHONE: (1)248-458-1527

FAX: (1)248-458-6255

Eastern Area

1070 N. Kimbles Road, Yardley, PA 19067

PHONE: (1)215-321-5530

FAX: (1)215-321-5534

200 Wheeler Rd., Burlington, MA 01803

PHONE: (1)781-270-7979; (1)781-229-5100

FAX: (1)781-229-9117

8000 Regency Parkway, Suite 280 Cary, NC 27511

PHONE: (1)919-460-0695

FAX: (1)919-460-0795

2321 Sidney St. Pittsburgh, PA 15203

PHONE: (1)412-381-1191

FAX: (1)412-381-1192

4875 North Federal Highway, Third Floor

Ft. Lauderdale, FL 33318

PHONE: (1)954-267-8883

FAX: (1)954-267-0254

EUROPESHARP MICROELECTRONICS EUROPE
A division of Sharp Electronics (Europe) GmbH**Head Office**

Sonninstrasse 3, 20097, Hamburg, Germany

PHONE: (49)180-5073507

FAX: (49)40-2376-2232

<http://www.sharpsme.com/>**Germany**

SME München Office

Fuerstenriederstrasse 5, 80687 München, Germany

PHONE: (49)89-5468420

FAX: (49)89-54 684250

France

SME Paris Office

1 Rue Raoul Follereau Bussy Saint Georges

77608 Marne la Vallee Cedex 3

PHONE: (33)1 6476 22 22

FAX: (33)1 6476 22 23

Italy

SME Milano Office

Centro Direzionale Colleoni

Palazzo Taurus Ingresso 2

20041 Agrate Brianza, Milano, Italy

PHONE: (390)39-68 99 946

FAX: (390)39-68 99 948

U.K .

SME London Office

Centennial Court, Easthampstead Road,

Bracknell, Berkshire R G12 1YQ, United Kingdom

PHONE: (44)1344-86 99 22

FAX: (44)1344-36 09 03

Ireland

SME Dublin Office

First Floor, Block 1, St. Johns Court, Santry,

Dublin 9, Ireland

PHONE: (353)1-842 87 05

FAX: (353)1-842 84 55

ASIA

SHARP ELECTRONICS (SHANGHAI) CO., LTD.

Microelectronics Sales & Marketing Division

16F, King Tower, 28 Xin Jin Qiao Road,

Pudong DIST, Shanghai 201206 P.R . China

PHONE: (86)21-5854-7710/21-5834-6056

FAX: (86)21-5854-4340/21-5834-6057

Registered AddressNo. 11, De Bao Road, Xin Development BLDG
46 Wai Gao Qiao Free Trade Zone, Shanghai
200131, P.R . China**Beijing Office**

Room 1062, Beijing Jing An Center No. 8 East

Bei San Huan Road, Chao Yang DIST, Beijing

100028 P.R . China

PHONE: (86) 10-6466-7543/10-6466-6561

FAX: (86) 10-6468-8920

[http://sharp-world.com/products/devicechina/](http://sharp-world.com/products/devicechina/index.html)[index.html](http://sharp-world.com/products/devicechina/index.html)**SHARP-ROXY (HONG KONG) LTD.**

Device Sales Division, 17/F, Admiralty Centre,

Tower 1, 18 Harcourt Road, Hong Kong

PHONE: (852)28229311

FAX: (852)28660779

<http://www.sharp.com.hk>**Shenzhen Representative Office**

Room 13B1, Tower C, Electronics Science &

Technology Building, Shen Nan Zhong Road,

Shenzhen, P.R . China

PHONE: (86)755-83273731

FAX: (86)755-83273735

SHARP ELECTRONIC COMPONENTS**(TAIWAN) CORPORATION**

8F-A, No. 16, Sec. 4, Nanking E. R d., Taipei, Taiwan

PHONE: (886)2-2577-7341

FAX: (886)2-2577-7326/2-2577-7328

SHARP ELECTRONICS (SINGAPORE) PTE ., LTD.

396 Alexandra Road #07-00

BP Tower Singapore 119954

PHONE: (65) 62713566

FAX: (65) 62713855

<http://www.sesi-sharp.com>**SHARP MICROELECTRONICS****TECHNOLOGY (M) SDN BHD.**

Suite E 408, 4th Floor, East Tower,

Wisma Consplant 1, No. 2 J In. SS 16/4,

Subng Jaya, 47500, Selangor Darul Ehsan, Malaysia

PHONE: (60) 3-5637-8964

FAX: (60) 3-5638-4029

SHARP ELECTRONIC COMPONENTS**(KOREA) CORPORATION**

RM 501 iLsin B/D. 541, Dohwa-dong,

Mapo-ku, Seoul, Korea, 121-701

PHONE: (82)2-711-5813 ~ 8

FAX: (82)2-711-5819

Distributed By

OUR CERTIFICATE

DiGi provide top-quality products and perfect service for customer worldwide through standardization, technological innovation and continuous improvement. DiGi through third-party certification, we stricly control the quality of products and services. Welcome your RFQ to

Email: Info@DiGi-Electronics.com



Tel: +00 852-30501935

RFQ Email: Info@DiGi-Electronics.com

DiGi is a global authorized distributor of electronic components.