

# PQ1X331M2ZPH Datasheet

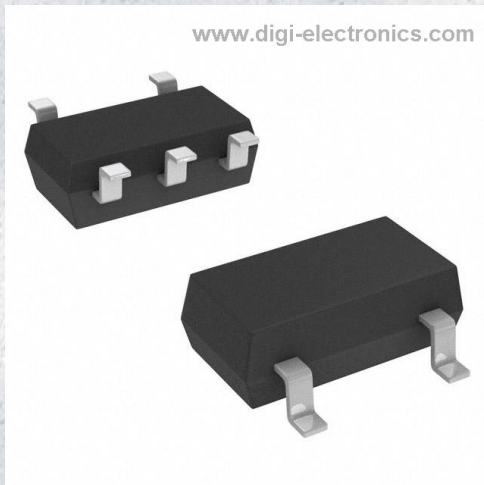

<https://www.DiGi-Electronics.com>

DiGi Electronics Part Number	PQ1X331M2ZPH-DG
Manufacturer	<a href="#">Sharp Microelectronics</a>
Manufacturer Product Number	PQ1X331M2ZPH
Description	IC REG LINEAR 3.3V 150MA SOT23-5
Detailed Description	Linear Voltage Regulator IC Positive Fixed 1 Output 150mA SOT-23-5

This model PQ1X331M2ZPH is available at DiGi Electronics.

DiGi Electronics offers a global database of semiconductor and electronic component datasheets.

We welcome your inquiries regarding pricing, lead time, or other product-related questions.

 [Request a Quote](#)

 [Datasheet Search](#)



Tel: +00 852-30501935

RFQ Email: [Info@DiGi-Electronics.com](mailto:Info@DiGi-Electronics.com)

DiGi is a global authorized distributor of electronic components.

## Purchase and inquiry

Manufacturer Product Number:

PQ1X331M2ZPH

Series:

-

Output Configuration:

Positive

Number of Regulators:

1

Voltage - Output (Min/Fixed):

3.3V

Voltage Dropout (Max):

0.4V @ 150mA

Current - Quiescent (Iq):

200  $\mu$ A

Control Features:

Enable

Operating Temperature:

-30°C ~ 85°C

Package / Case:

SC-74A, SOT-753

Base Product Number:

PQ1X

Manufacturer:

Sharp Microelectronics

Product Status:

Obsolete

Output Type:

Fixed

Voltage - Input (Max):

9V

Voltage - Output (Max):

-

Current - Output:

150mA

PSRR:

70dB (400Hz)

Protection Features:

Over Current, Over Temperature

Mounting Type:

Surface Mount

Supplier Device Package:

SOT-23-5

## Environmental & Export classification

Moisture Sensitivity Level (MSL):

1 (Unlimited)

HTSUS:

8542.39.0001

ECCN:

EAR99

# PQ1Xxx1M2ZPH Series

Low Output Current, Compact Surface Mount Type  
Low Power-Loss Voltage Regulators

## Features

- 1.Compact surface mount package (2.9×1.6×1.1mm)
- 2.Low power-loss  
(Dropout voltage: TYP. 0.11 V/MAX. 0.26V at  $I_o=60\text{mA}$ )  
Also compatible ceramic capacitors because of suppressing oscillation level
- 3.High ripple rejection (TYP. 70dB)
- 4.Built-in ON/OFF control function  
(Dissipation current at OFF-state: MAX. 1 $\mu\text{A}$ )
- 5.Built-in overcurrent and overheat protection functions  
\*It is available for every 0.1V of output voltage (1.3V to 5.0V)
- 6.RoHS directive compliant

## Applications

- 1.Cellular phones
- 2.Cordless phones
- 3.Personal information tools (PDA)
- 4.Cameras/Camcoders
- 5.PCMCIA cards for notebook PCs

## Model Line-up

Output Voltage (TYP.)	Model No.	Output Voltage (TYP.)	Model No.
1.5V	PQ1X151M2ZPH	3.0V	PQ1X301M2ZPH
1.8V	PQ1X181M2ZPH	3.3V	PQ1X331M2ZPH
2.5V	PQ1X251M2ZPH	3.5V	PQ1X351M2ZPH
2.6V	PQ1X261M2ZPH	3.7V	PQ1X371M2ZPH
2.7V	PQ1X271M2ZPH	4.0V	PQ1X401M2ZPH
2.8V	PQ1X281M2ZPH	4.5V	PQ1X451M2ZPH
2.9V	PQ1X291M2ZPH	5.0V	PQ1X501M2ZPH

## Absolute Maximum Ratings

(Ta=25°C)

Parameter	Symbol	Rating	Unit
*1 Input voltage	$V_{IN}$	9	V
*1 ON/OFF control terminal voltage	$V_C$	9	V
Output current	$I_o$	300	mA
*2 Power dissipation	$P_D$	350	mW
*3 Junction temperature	$T_j$	150	°C
Operating temperature	$T_{opr}$	-30 to +85	°C
Storage temperature	$T_{stg}$	-55 to +150	°C
Soldering temperature	$T_{sol}$	270(10s)	°C

\*1 All are open except GND and applicable terminals.

\*2 At mounted on PCB

\*3 Overheat protection may operate at  $T_j:125^\circ\text{C}$  to  $150^\circ\text{C}$ 

## Outline Dimensions

(Unit : mm)

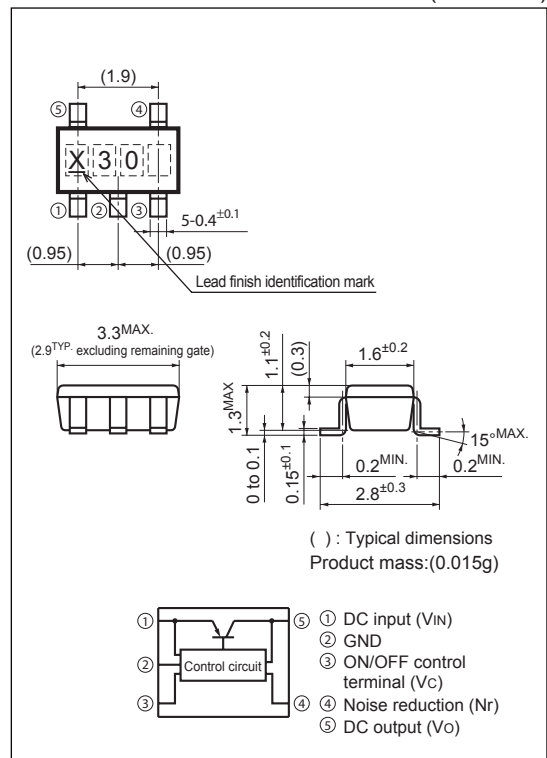

Lead finish:Lead-free solder plating  
(Composition: Sn2Cu)

Notice The content of data sheet is subject to change without prior notice.

In the absence of confirmation by device specification sheets, SHARP takes no responsibility for any defects that may occur in equipment using any SHARP devices shown in catalogs, data books, etc. Contact SHARP in order to obtain the latest device specification sheets before using any SHARP device.

## Electrical Characteristics

(Unless otherwise specified,  $V_{IN}=V_O(\text{TYP}) + 1.0\text{V}$ ,  $I_O=30\text{mA}$ ,  $V_C=1.8\text{V}$ ,  $T_a=25^\circ\text{C}$ )

Parameter	Symbol	Conditions	MIN.	TYP.	MAX.	Unit
Output voltage	$V_O$	-	Refer to the following table.1			V
*4 Input voltage	$V_{IN}$	-	2.3	-	9	V
*5 Output peak current	$I_{OP}$	-	180	300	-	mA
Recommended output current	-	-	-	-	150	mA
Load regulation	RegL1	$I_O=5$ to 60mA	-	10	50	mV
	RegL2	$I_O=5$ to 100mA	-	20	100	mV
	RegL3	$I_O=5$ to 150mA	-	40	160	mV
Line regulation	RegL	$V_{IN}=V_O(\text{TYP})+1\text{V}$ to $V_O(\text{TYP})+6\text{V}(\text{MAX.}9.0\text{V})$	-	3.0	20	mV
Temperature coefficient of output voltage	$T_C V_O$	$I_O=10\text{mA}$ , $T_j=-25$ to $+75^\circ\text{C}$	-	0.05	-	mV/ $^\circ\text{C}$
Ripple rejection	RR	Refer to Fig.2	-	70	-	dB
Output noise voltage	$V_{NO}(\text{rms})$	$10\text{Hz}<f<100\text{kHz}$ , $C_n F=0.1\mu\text{F}$ , $I_O=30\text{mA}$	Refer to the following table.2			$\mu\text{V}$
*6 Dropout voltage	$V_{I-O1}$	$I_O=60\text{mA}$ *7	-	0.11	0.26	V
	$V_{I-O2}$	$I_O=150\text{mA}$ *7	-	0.20	0.4	
*8 ON-state voltage for control	$V_{C(\text{ON})}$	-	1.8	-	-	V
ON-state current for control	$I_{C(\text{ON})}$	$V_C=1.8\text{V}$	-	5	30	$\mu\text{A}$
OFF-state voltage for control	$V_{C(\text{OFF})}$	-	-	-	0.4	V
Quiescent current	$I_Q$	$I_O=0\text{mA}$	-	150	200	$\mu\text{A}$
Output OFF-state dissipation current	$I_{QS}$	$V_C=0.2\text{V}$	-	-	1	$\mu\text{A}$

\*4 Applied to PQ1X151M2ZPH and PQ1X181M2ZPH

\*5 Output current shall be the value when output voltage lowers 0.3V from the voltage at  $I_O=30\text{mA}$ .

\*6 Excluding PQ1X151M2ZPH and PQ1X181M2ZPH

\*7 Input voltage when output voltage falls 0.1V from that at  $V_{IN}=V_O(\text{TYP})+1.0\text{V}$ .

\*8 In case that the control terminal (③ pin) is open, output voltage should be OFF state.

Table.1 Output Voltage

 $(V_{IN}=V_O(\text{TYP})+1.0\text{V}$ ,  $I_O=30\text{mA}$ ,  $V_C=1.8\text{V}$ ,  $T_a=25^\circ\text{C}$ )

Model No.	Symbol	MIN.	TYP.	MAX.	Unit
PQ1X151M2ZPH	$V_O$	1.440	1.5	1.560	V
PQ1X181M2ZPH		1.740	1.8	1.860	
PQ1X251M2ZPH		2.440	2.5	2.560	
PQ1X261M2ZPH		2.540	2.6	2.660	
PQ1X271M2ZPH		2.640	2.7	2.760	
PQ1X281M2ZPH		2.740	2.8	2.860	
PQ1X291M2ZPH		2.840	2.9	2.960	
PQ1X301M2ZPH		2.940	3.0	3.060	
PQ1X331M2ZPH		3.234	3.3	3.366	
PQ1X351M2ZPH		3.430	3.5	3.570	
PQ1X371M2ZPH		3.626	3.7	3.774	
PQ1X401M2ZPH		3.920	4.0	4.080	
PQ1X451M2ZPH		4.410	4.5	4.590	
PQ1X501M2ZPH		4.900	5.0	5.100	

Table.2 Output Noise Voltage

 $(V_{IN}=V_O(\text{TYP})+1.0\text{V}$ ,  $I_O=30\text{mA}$ ,  $V_C=1.8\text{V}$ ,  $C_n=0.1\mu\text{F}$ ,  $10\text{Hz}<f<100\text{kHz}$ ,  $T_a=25^\circ\text{C}$ )

Model No.	Symbol	MIN.	TYP.	MAX.	Unit
PQ1X151M2ZPH	$V_{NO}(\text{rms})$	-	15	-	$\mu\text{V}$
PQ1X181M2ZPH		-	15	-	
PQ1X251M2ZPH		-	25	-	
PQ1X261M2ZPH		-	25	-	
PQ1X271M2ZPH		-	25	-	
PQ1X281M2ZPH		-	25	-	
PQ1X291M2ZPH		-	25	-	
PQ1X301M2ZPH		-	30	-	
PQ1X331M2ZPH		-	30	-	
PQ1X351M2ZPH		-	35	-	
PQ1X371M2ZPH		-	35	-	
PQ1X401M2ZPH		-	40	-	
PQ1X451M2ZPH		-	45	-	
PQ1X501M2ZPH		-	50	-	

Fig.1 Test Circuit

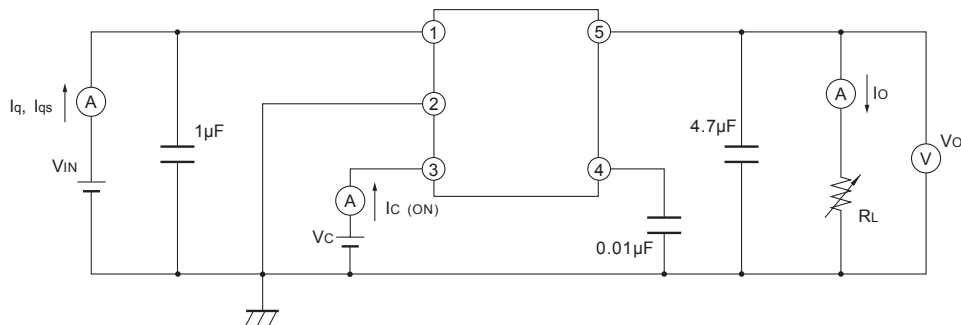

Fig.2 Test Circuit for Ripple Rejection

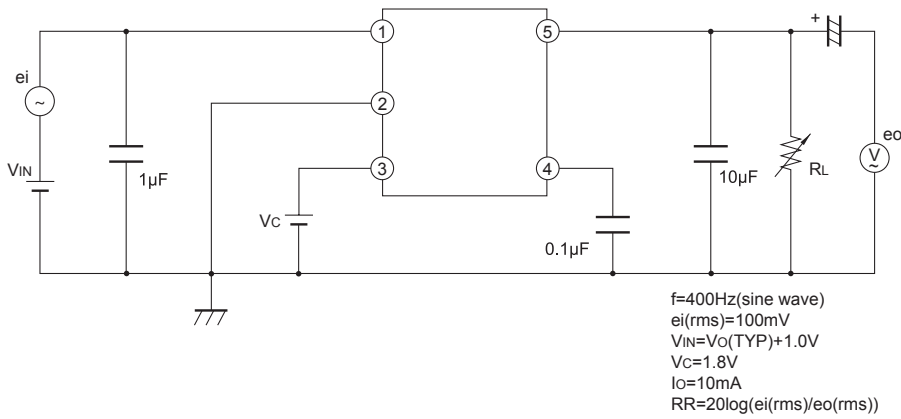
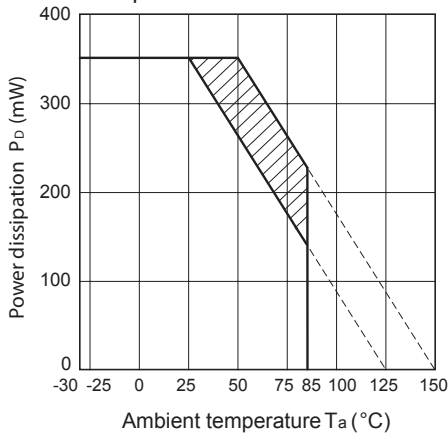

Fig.3 Power Dissipation vs. Ambient Temperature



Note) Oblique line portion: Overheat protection may operate in this area.

Fig.4 Overcurrent Protection Characteristics (Typical Value)

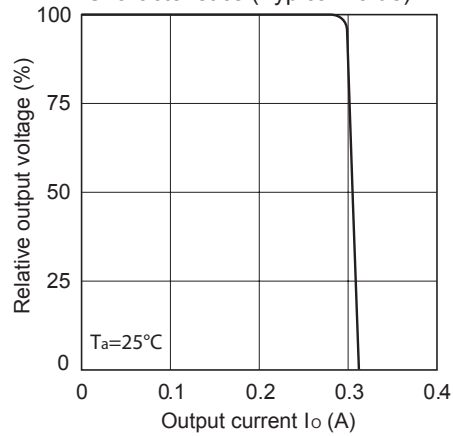

Fig.5 Output Voltage Fluctuation vs. Junction Temperature (PQ1X301M2ZPH)(Typical Value)

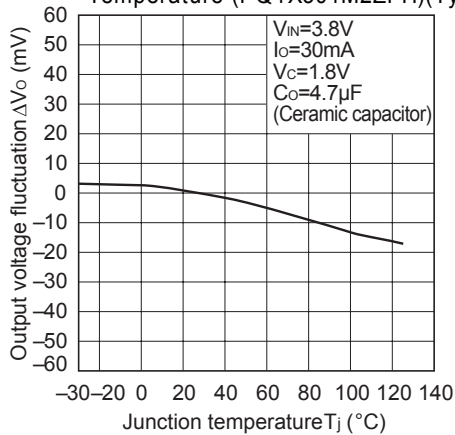

Fig.6 Output Voltage vs. Input Voltage (PQ1X301M2ZPH)(Typical Value)

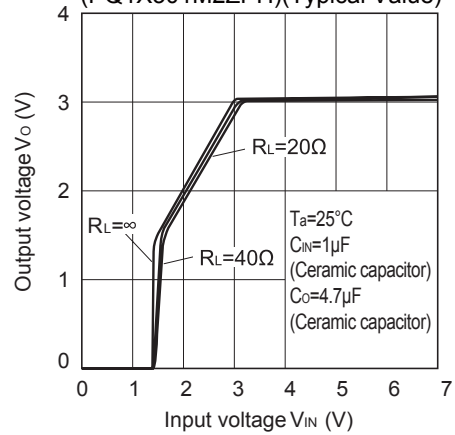

Fig.7 Circuit Operating Current vs. Input Voltage (PQ1X301M2ZPH)(Typical Value)

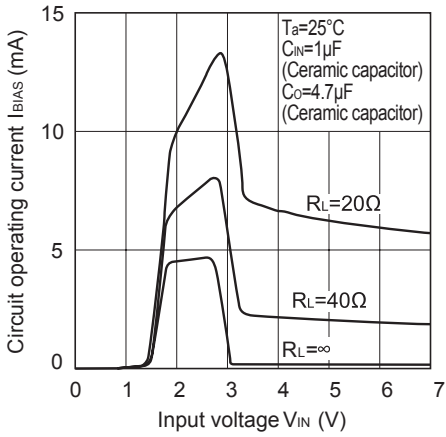

Fig.8 Dropout Voltage vs. Junction Temperature (PQ1X301M2ZPH)(Typical Value)

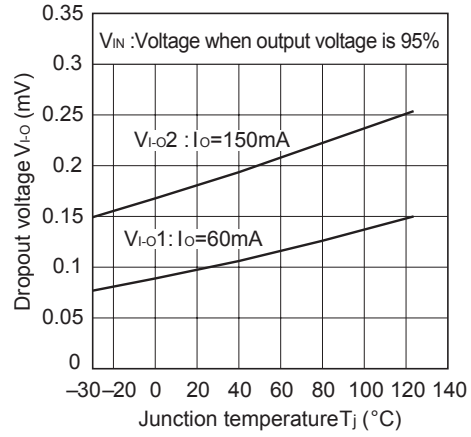

Fig.9 Quiescent Current vs. Junction Temperature (Typical Value)

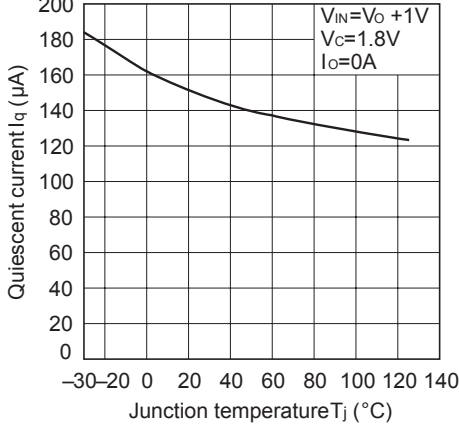

Fig.10 Ripple Rejection vs. Input Ripple Frequency (PQ1X281M2ZPH)(Typical Value)

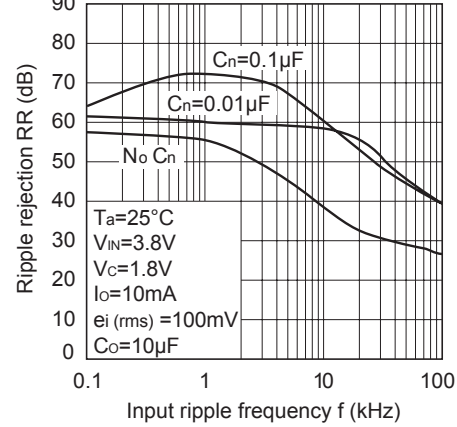
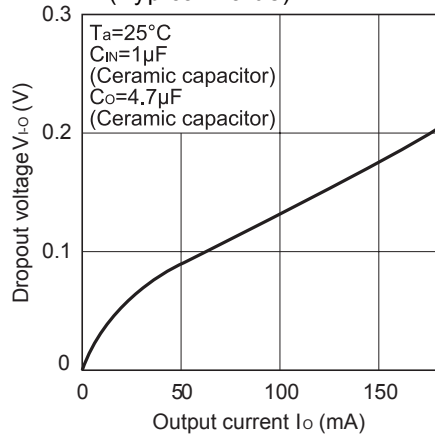

Fig.11 Dropout Voltage vs. Output Current (Typical Value)



## OUR CERTIFICATE

DiGi provide top-quality products and perfect service for customer worldwide through standardization, technological innovation and continuous improvement. DiGi through third-party certification, we stricly control the quality of products and services. Welcome your RFQ to

Email: [Info@DiGi-Electronics.com](mailto:Info@DiGi-Electronics.com)



Tel: +00 852-30501935

RFQ Email: [Info@DiGi-Electronics.com](mailto:Info@DiGi-Electronics.com)

DiGi is a global authorized distributor of electronic components.