

SI2157-A30-GMR Datasheet

www.digi-electronics.com

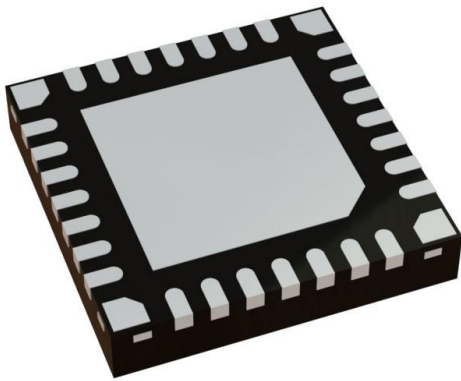

<https://www.DiGi-Electronics.com>

DiGi Electronics Part Number	SI2157-A30-GMR-DG
Manufacturer	Skyworks Solutions Inc.
Manufacturer Product Number	SI2157-A30-GMR
Description	IC VIDEO TUNER 28QFN
Detailed Description	Video Tuner IC GPIO NTSC, PAL, SECAM 28-QFN (4x4) Package

This model SI2157-A30-GMR is available at DiGi Electronics.

DiGi Electronics offers a global database of semiconductor and electronic component datasheets.

We welcome your inquiries regarding pricing, lead time, or other product-related questions.

 [Request a Quote](#)

 [Datasheet Search](#)



Tel: +00 852-30501935

RFQ Email: Info@DiGi-Electronics.com

DiGi is a global authorized distributor of electronic components.

Purchase and inquiry

Manufacturer Product Number:

SI2157-A30-GMR

Series:

-

Function:

Tuner

Standards:

NTSC, PAL, SECAM

Voltage - Supply:

1.8V, 3.3V

Package / Case:

28-VFQFN Exposed Pad

Base Product Number:

SI2157

Manufacturer:

Skyworks Solutions Inc.

Product Status:

Not For New Designs

Applications:

Professional Video

Control Interface:

GPIO

Mounting Type:

Surface Mount

Supplier Device Package:

28-QFN (4x4)

Environmental & Export classification

Moisture Sensitivity Level (MSL):

2 (1 Year)

HTSUS:

8542.39.0001

ECCN:

EAR99



Si2157

Worldwide Digital and Analog TV Tuner

Description

A universal hybrid TV tuner, the Si2157 supports digital and analog reception for all worldwide terrestrial and cable TV standards. By combining Silicon Laboratories' proven digital low-IF architecture with a 5th-generation RF front-end, the Si2157 maintains the highest performance that exceeds that of MOPLL-based tuners, including industry-leading 2nd order distortion performance. Pin- and API-compatibility to the previous generation minimize customers' development effort.

The Si2157 delivers unprecedented integration with no external balun, tracking filters, LNAs, SAW filters, or inductive power supply filtering. While other solutions may also eliminate the balun, they suffer degradation in NF and 2nd order distortion compromising reception. Silicon Laboratories' proprietary and field-proven architecture delivers not only an optimized BOM but also world-class system performance. Options for single or dual supply and internal power-on reset are included. A harmonic rejection mixer delivers outstanding immunity to Wi-Fi and LTE interference, replacing the need for external filtering.

For advanced digital terrestrial TV reception, DVB-T2 and DVB-C2 constellations demand outstanding phase noise specifications, and the Si2157 rises to the challenge, delivering industry-leading integrated phase noise. Additionally, a software-selectable cable mode offers optimized return loss.

The Si2157 delivers exceptional picture quality and a higher number of received stations when compared to other solutions. Incorporating worldwide field experience from four prior tuner generations in mass production, the Si2157 delivers the highest tolerance to real-world reception conditions.

Features

- Worldwide hybrid TV tuner
 - Analog TV: NTSC, PAL/SECAM
 - Digital TV: ATSC/QAM, DVB-T2/T/C2/C, ISDB-T/C, DTMB
- Industry-leading margin to A/74, NorDig, D-Book, C-Book, ARIB, EN55020, OpenCable™ specifications
- Lowest BOM for a silicon hybrid TV tuner
 - No balun
 - No SAW filters or wire-wound inductors
 - Integrated LNAs and complete tracking filters
- Best-in-class real-world reception
 - Exceeds discrete MOPLL-based tuners
 - Industry-leading phase noise performance
 - High immunity to Wi-Fi and LTE interference
- Low power consumption
 - 3.3 V and 1.8 V power supplies
 - Single-supply option for 3.3 V-only operation
- Integrated power-on reset circuit
- Flexible output interface
 - Combined ALIF/DLIF output to SoC
 - Optional DLIF output to external demodulator
- Standard CMOS process technology
- 4x4 mm, 28-pin QFN package
- RoHS compliant

Applications

- Hybrid ½-NIM tuner module
- iDTV (Integrated Digital TV)
- Hybrid terrestrial and cable STB
- Hybrid PVR, DVD and Blu-Ray disc recorder
- PC-TV accessories

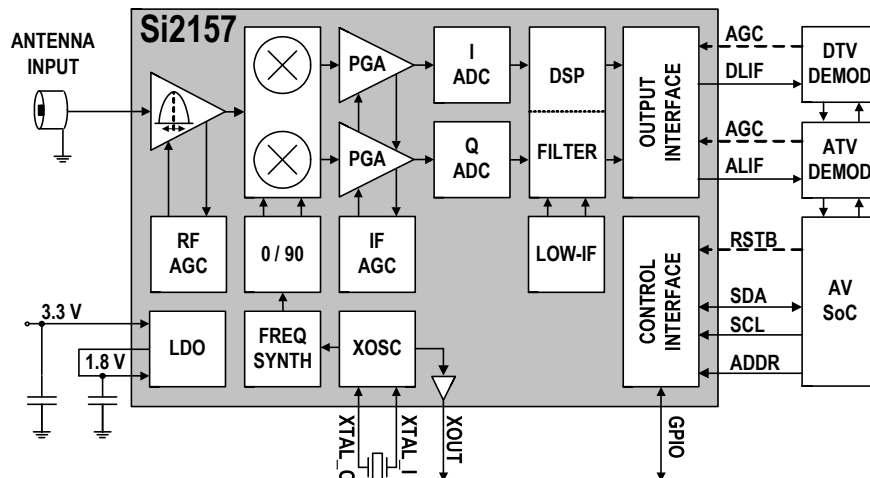



Si2157

Worldwide Digital and Analog TV Tuner

Selected Electrical Specifications

($V_{DD_H}=3.3\text{ V}$, $V_{DD_L}=1.8\text{ V}$, $V_{DD_D}=1.8\text{ V}$, $T_A=25\text{ }^\circ\text{C}$)

Parameter	Test Condition	Typ	Unit
Supply voltage		1.8 and 3.3, or only 3.3	V
Total Power Consumption	ATV Mode, XOUT Disabled	496	mW
RF Input Frequency Range		42 to 870	MHz
NF, terrestrial*	VHF-L	4.0	dB
	VHF-H	3.7	dB
	UHF	3.8	dB
Return Loss*	Terrestrial mode	3	dB
	Cable mode	9	dB
Wideband IIP3*	VHF-H, $N\pm 18$, ± 36	+5	dBm
Inband IIP3*	VHF-H, $N\pm 1$, ± 2	-6	dBm
LO Phase Noise at 860 MHz	1 kHz 10 kHz 100 kHz 1 MHz	-100 -100 -105 -132	dBc/Hz
LO Integrated Phase Noise at 860 MHz	DSB: 125 Hz to 4 MHz	0.25 (-47)	$^\circ$ rms (dBc)
Analog IF Spurious Distortion	S=P	-72	dB
ALIF/DLIF Output Center Frequency	channel BW=6 MHz 7 MHz 8 MHz	4 to 7 4.5 to 6.5 5 to 6	MHz
ALIF/DLIF Differential Output Voltage	Programmable	0.5 to 2.0	Vppd
*Note: Measured at the F-connector input of the Si2157 EVB and includes all connector, PCB, and front-end circuit losses.			

Selection Guide

Part #	Description
Si2157	Worldwide hybrid TV tuner for NTSC, PAL/SECAM, ATSC/QAM, DVB-T2/T/C2/C, ISDB-T/C, DTMB

Pin Assignments

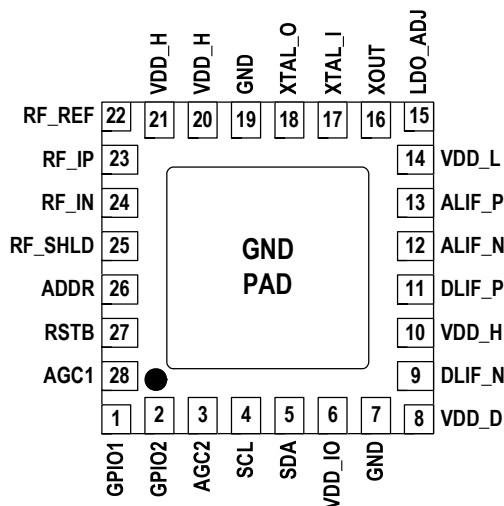

4x4 mm QFN-28 Package Information

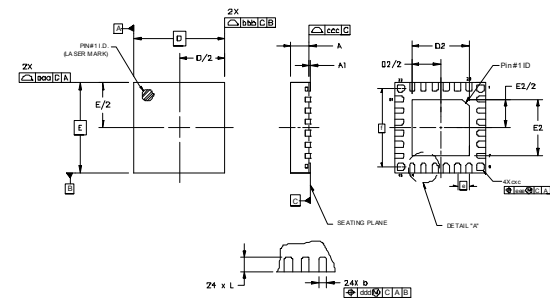

Symbol	Min	Nom	Max	Unit
A	0.80	0.85	0.90	mm
D, E	4.00 BSC			mm
e	0.50 BSC			mm
f	3.50 BSC			mm

OUR CERTIFICATE

DiGi provide top-quality products and perfect service for customer worldwide through standardization, technological innovation and continuous improvement. DiGi through third-party certification, we strictly control the quality of products and services. Welcome your RFQ to

Email: Info@DiGi-Electronics.com



Tel: +00 852-30501935

RFQ Email: Info@DiGi-Electronics.com

DiGi is a global authorized distributor of electronic components.