

2N1893 Datasheet

www.digi-electronics.com



2N1893

<https://www.DiGi-Electronics.com>

DiGi Electronics Part Number	2N1893-DG
Manufacturer	STMicroelectronics
Manufacturer Product Number	2N1893
Description	TRANS NPN 80V 0.5A TO39
Detailed Description	Bipolar (BJT) Transistor NPN 80 V 500 mA 70MHz 800 mW Through Hole TO-39



Tel: +00 852-30501935

RFQ Email: Info@DiGi-Electronics.com

DiGi is a global authorized distributor of electronic components.

Purchase and inquiry

Manufacturer Product Number:

2N1893

Series:

-

Transistor Type:

NPN

Voltage - Collector Emitter Breakdown (Max):

80 V

Current - Collector Cutoff (Max):

10nA (ICBO)

Power - Max:

800 mW

Operating Temperature:

175°C (TJ)

Package / Case:

TO-205AD, TO-39-3 Metal Can

Base Product Number:

2N18

Manufacturer:

STMicroelectronics

Product Status:

Obsolete

Current - Collector (Ic) (Max):

500 mA

Vce Saturation (Max) @ Ib, Ic:

5V @ 15mA, 150mA

DC Current Gain (hFE) (Min) @ Ic, Vce:

40 @ 150mA, 10V

Frequency - Transition:

70MHz

Mounting Type:

Through Hole

Supplier Device Package:

TO-39

Environmental & Export classification

RoHS Status:

ROHS3 Compliant

REACH Status:

REACH Unaffected

HTSUS:

8541.21.0095

Moisture Sensitivity Level (MSL):

1 (Unlimited)

ECCN:

EAR99



2N1893

SMALL SIGNAL NPN TRANSISTOR

- GENERAL PURPOSE HIGH VOLTAGE DEVICE

DESCRIPTION

The 2N1893 is a Silicon Planar Epitaxial NPN transistor in Jedec TO-39 metal case, designed for use in high-performance amplifier, oscillator and switching circuits. It provides greater voltage swings in oscillator and amplifier circuits and more protection in inductive switching circuits due to its 120 V collector-to-base voltage rating.

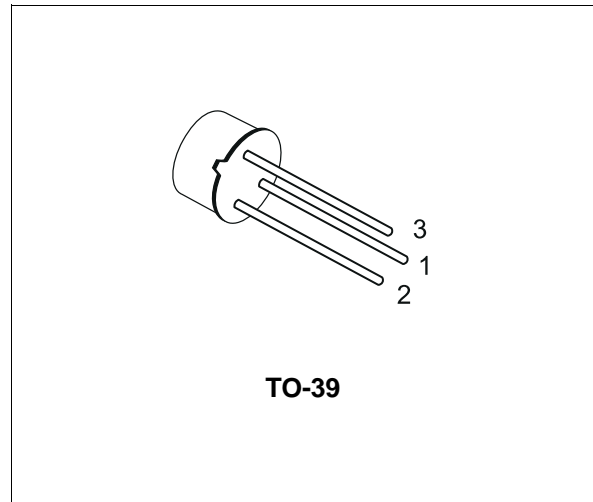

INTERNAL SCHEMATIC DIAGRAM

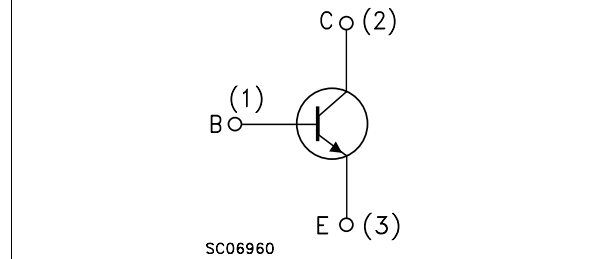

ABSOLUTE MAXIMUM RATINGS

Symbol	Parameter	Value	Unit
V_{CBO}	Collector-Base Voltage ($I_E = 0$)	120	V
V_{CER}	Collector-Emitter Voltage ($R_{BE} \leq 10\Omega$)	100	V
V_{CEO}	Collector-Emitter Voltage ($I_B = 0$)	80	V
V_{EBO}	Emitter-Base Voltage ($I_C = 0$)	7	V
I_C	Collector Current	0.5	A
P_{tot}	Total Dissipation at $T_{amb} \leq 25^\circ\text{C}$ at $T_C \leq 25^\circ\text{C}$ at $T_C \leq 100^\circ\text{C}$	0.8	W
		3	W
		1.7	W
T_{stg}	Storage Temperature	-65 to 175	$^\circ\text{C}$
T_j	Max. Operating Junction Temperature	175	$^\circ\text{C}$

2N1893

THERMAL DATA

R _{thj-case}	Thermal Resistance Junction-Case	Max	50	°C/W
R _{thj-amb}	Thermal Resistance Junction-Ambient	Max	187.5	°C/W

ELECTRICAL CHARACTERISTICS (T_{case} = 25 °C unless otherwise specified)

Symbol	Parameter	Test Conditions	Min.	Typ.	Max.	Unit
I _{CBO}	Collector Cut-off Current (I _E = 0)	V _{CB} = 90 V V _{CB} = 90 V T _C = 150 °C			10 15	nA μA
I _{EBO}	Emitter Cut-off Current (I _C = 0)	V _{EB} = 5 V			10	nA
V _{(BR)CBO}	Collector-Base Breakdown Voltage (I _E = 0)	I _C = 100 μA	120			V
V _{(BR)CER*}	Collector-Emitter Breakdown Voltage (R _{BE} ≤ 10 Ω)	I _C = 10 mA	100			V
V _{(BR)CEO*}	Collector-Emitter Breakdown Voltage (I _B = 0)	I _C = 10 mA	80			V
V _{(BR)EBO}	Emitter-Base Breakdown Voltage (I _C = 0)	I _E = 100 μA	7			V
V _{CE(sat)*}	Collector-Emitter Saturation Voltage	I _C = 50 mA I _B = 5 mA I _C = 150 mA I _B = 15 mA			1.2 5	V V
V _{BE(sat)*}	Base-Emitter Saturation Voltage	I _C = 50 mA I _B = 5 mA I _C = 150 mA I _B = 15 mA		0.82 0.96	0.9 1.3	V V
h _{FE*}	DC Current Gain	I _C = 0.1 mA V _{CE} = 10 V I _C = 10 mA V _{CE} = 10 V I _C = 150 mA V _{CE} = 10 V I _C = 10 mA V _{CE} = 10 V T _C = -55 °C	20 35 40 20	50 80 80 40	120	
h _{fe*}	Small Signal Current Gain	I _C = 1 mA V _{CE} = 5 V f = 1KHz I _C = 5 mA V _{CE} = 10 V f = 1KHz	30 45	70 85	150	
f _T	Transition Frequency	I _C = 50 mA V _{CE} = 10 V f = 20MHz	50	70		MHz
C _{CBO}	Collector-Base Capacitance	I _E = 0 V _{CB} = 10 V f = 1MHz		13	15	pF
C _{EBO}	Emitter-Base Capacitance	I _C = 0 V _{EB} = 0.5 V f = 1MHz		55	85	pF

* Pulsed: Pulse duration = 300 μs, duty cycle ≤ 1 %

DC Current Gain

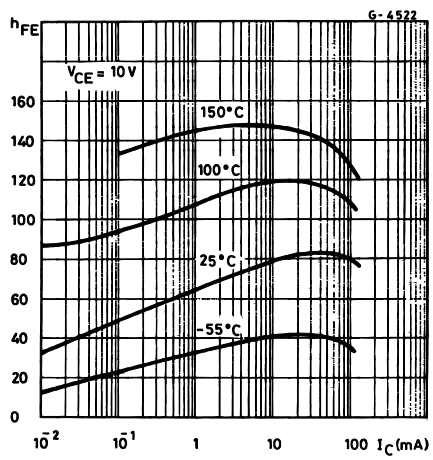

DC Current Gain

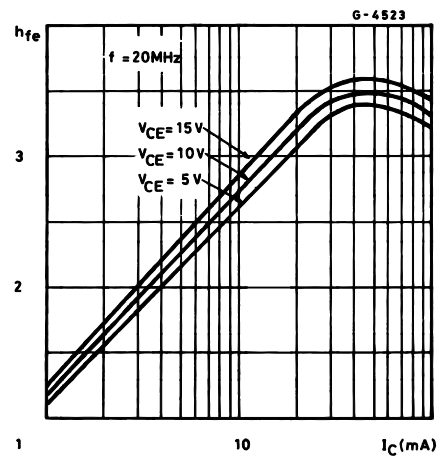

2N1893

TO-39 MECHANICAL DATA

DIM.	mm			inch		
	MIN.	TYP.	MAX.	MIN.	TYP.	MAX.
A	12.7			0.500		
B			0.49			0.019
D			6.6			0.260
E			8.5			0.334
F			9.4			0.370
G	5.08			0.200		
H			1.2			0.047
I			0.9			0.035
L	45° (typ.)					

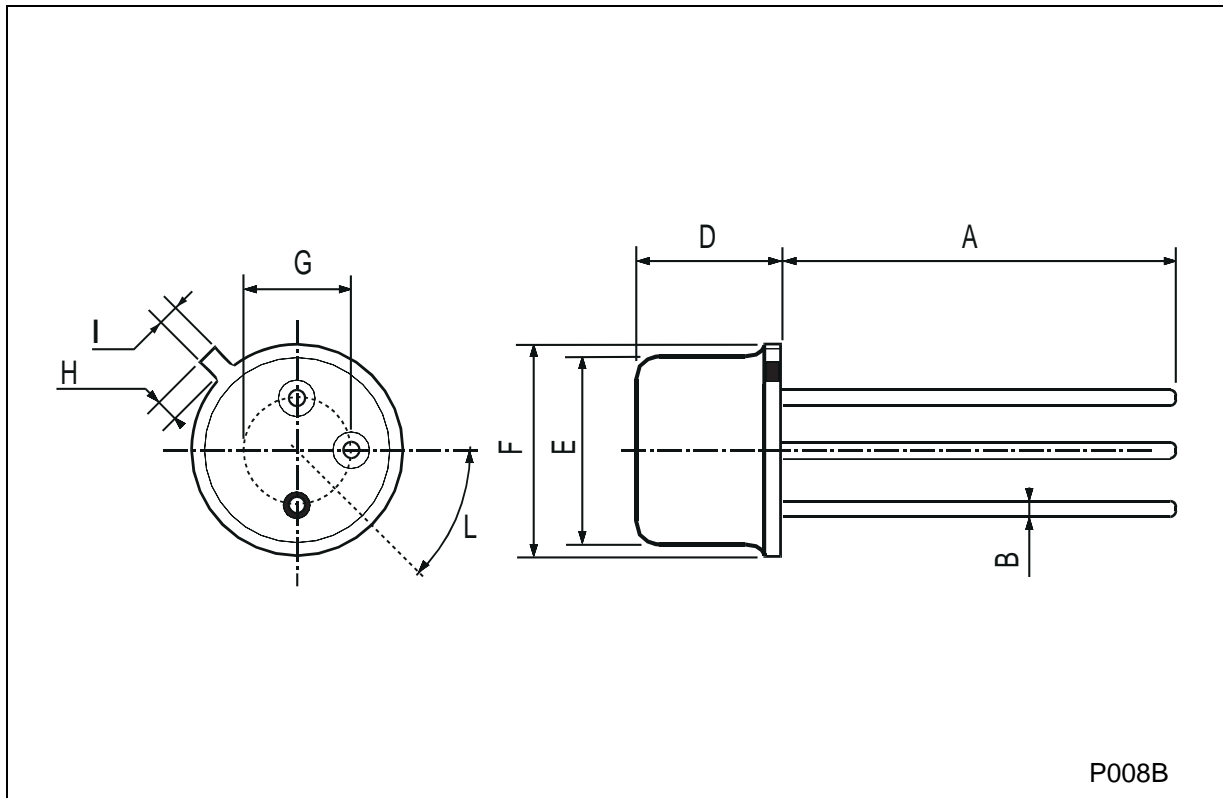

Information furnished is believed to be accurate and reliable. However, STMicroelectronics assumes no responsibility for the consequences of use of such information nor for any infringement of patents or other rights of third parties which may result from its use. No license is granted by implication or otherwise under any patent or patent rights of STMicroelectronics. Specification mentioned in this publication are subject to change without notice. This publication supersedes and replaces all information previously supplied. STMicroelectronics products are not authorized for use as critical components in life support devices or systems without express written approval of STMicroelectronics.

The ST logo is a trademark of STMicroelectronics

© 2002 STMicroelectronics – Printed in Italy – All Rights Reserved

STMicroelectronics GROUP OF COMPANIES

Australia - Brazil - Canada - China - Finland - France - Germany - Hong Kong - India - Israel - Italy - Japan - Malaysia - Malta - Morocco - Singapore - Spain - Sweden - Switzerland - United Kingdom - United States.

<http://www.st.com>



OUR CERTIFICATE

DiGi provide top-quality products and perfect service for customer worldwide through standardization, technological innovation and continuous improvement. DiGi through third-party certification, we stricly control the quality of products and services. Welcome your RFQ to

Email: Info@DiGi-Electronics.com



Tel: +00 852-30501935

RFQ Email: Info@DiGi-Electronics.com

DiGi is a global authorized distributor of electronic components.