

2N2369A Datasheet

www.digi-electronics.com



2N2369A

<https://www.DiGi-Electronics.com>

DiGi Electronics Part Number	2N2369A-DG
Manufacturer	STMicroelectronics
Manufacturer Product Number	2N2369A
Description	TRANS NPN 15V 0.2A TO18
Detailed Description	Bipolar (BJT) Transistor NPN 15 V 200 mA 675MHz 3 60 mW Through Hole TO-18



Tel: +00 852-30501935

RFQ Email: Info@DiGi-Electronics.com

DiGi is a global authorized distributor of electronic components.

Purchase and inquiry

Manufacturer Product Number:

2N2369A

Series:

-

Transistor Type:

NPN

Voltage - Collector Emitter Breakdown (Max):

15 V

Current - Collector Cutoff (Max):

400nA

Power - Max:

360 mW

Operating Temperature:

-65°C ~ 200°C (TJ)

Package / Case:

TO-206AA, TO-18-3 Metal Can

Base Product Number:

2N23

Manufacturer:

STMicroelectronics

Product Status:

Obsolete

Current - Collector (Ic) (Max):

200 mA

Vce Saturation (Max) @ Ib, Ic:

500mV @ 10mA, 100mA

DC Current Gain (hFE) (Min) @ Ic, Vce:

40 @ 10mA, 1V

Frequency - Transition:

675MHz

Mounting Type:

Through Hole

Supplier Device Package:

TO-18

Environmental & Export classification

RoHS Status:

RoHS non-compliant

REACH Status:

REACH Unaffected

HTSUS:

8541.21.0075

Moisture Sensitivity Level (MSL):

1 (Unlimited)

ECCN:

EAR99

HIGH-SPEED SATURATED SWITCH

DESCRIPTION

The 2N2369A is a silicon planar epitaxial NPN transistor in Jedec TO-18 metal case. It is designed specifically for high-speed saturated switching applications at current levels from 100 μ A to 100 mA.

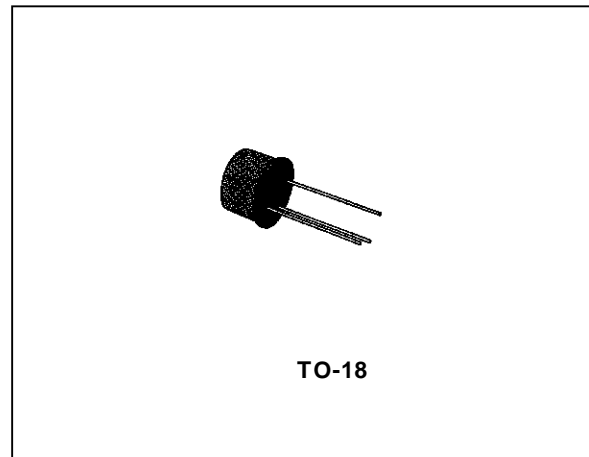

INTERNAL SCHEMATIC DIAGRAM

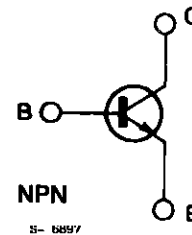

ABSOLUTE MAXIMUM RATINGS

Symbol	Parameter	Value	Unit
V_{CBO}	Collector-base Voltage ($I_E = 0$)	40	V
V_{CES}	Collector-emitter Voltage ($V_{BE} = 0$)	40	V
V_{CEO}	Collector-emitter Voltage ($I_B = 0$)	15	V
V_{EBO}	Emitter-base Voltage ($I_C = 0$)	4.5	V
I_C	Collector Current	0.2	A
I_{CM}	Collector Current (10 μ s pulse)	0.5	A
P_{tot}	Total Power Dissipation at $T_{amb} \leq 25\text{ }^\circ\text{C}$	0.36	W
	at $T_{case} \leq 25\text{ }^\circ\text{C}$	1.2	W
	at $T_{case} \leq 100\text{ }^\circ\text{C}$	0.68	W
T_{stg}, T_j	Storage and Junction Temperature	- 65 to 200	$^\circ\text{C}$

2N2369A**THERMAL DATA**

$R_{th\ j-case}$	Thermal Resistance Junction-case	Max	146	°C/W
$R_{th\ j-amb}$	Thermal Resistance Junction-ambient	Max	486	°C/W

ELECTRICAL CHARACTERISTICS ($T_{amb} = 25\text{ °C}$ unless otherwise specified)

Symbol	Parameter	Test Conditions	Min.	Typ.	Max.	Unit
I_{CBO}	Collector Cutoff Current ($I_E = 0$)	$V_{CB} = 20\text{ V}$ $T_{amb} = 150\text{ °C}$			30	μA
I_{CES}	Collector Cutoff Current ($V_{BE} = 0$)	$V_{CE} = 20\text{ V}$			0.4	μA
$V_{(BR)CBO}$	Collector-base Breakdown Voltage ($I_E = 0$)	$I_C = 10\ \mu\text{A}$	40			V
$V_{(BR)CES}$	Collector-emitter Breakdown Voltage ($V_{BE} = 0$)	$I_C = 10\ \mu\text{A}$	40			V
$V_{(BR)CEO}^*$	Collector-emitter Breakdown Voltage ($I_B = 0$)	$I_C = 10\text{ mA}$	15			V
$V_{(BR)EBO}$	Emitter-base Breakdown Voltage ($I_C = 0$)	$I_E = 10\ \mu\text{A}$	4.5			V
$V_{CE(sat)}^*$	Collector-emitter Saturation Voltage	$I_C = 10\text{ mA}$ $I_B = 1\text{ mA}$ $I_C = 30\text{ mA}$ $I_B = 3\text{ mA}$ $I_C = 100\text{ mA}$ $I_B = 10\text{ mA}$ $I_C = 10\text{ mA}$ $I_B = 1\text{ mA}$ $T_{amb} = 125\text{ °C}$		0.14 0.17 0.28 0.19	0.2 0.25 0.5 0.3	V V V V
$V_{BE(sat)}^*$	Base-emitter Saturation Voltage	$I_C = 10\text{ mA}$ $I_B = 1\text{ mA}$ $I_B = 30\text{ mA}$ $I_B = 3\text{ mA}$ $I_C = 100\text{ mA}$ $I_B = 10\text{ mA}$ $I_C = 10\text{ mA}$ $I_B = 1\text{ mA}$ $T_{amb} = -55\text{ to }125\text{ °C}$	0.7 0.59	0.8 0.9 1.1	0.85 1.15 1.6 1.02	V V V V
h_{FE}^*	DC Current Gain	$I_C = 10\text{ mA}$ $V_{CE} = 0.35\text{ V}$ $I_C = 10\text{ mA}$ $V_{CE} = 1\text{ V}$ $I_C = 30\text{ mA}$ $V_{CE} = 0.4\text{ V}$ $I_C = 100\text{ mA}$ $V_{CE} = 1\text{ V}$	40 40 30 20	63 66 71	120 120	
h_{FE}^*	DC Current Gain	$I_C = 10\text{ mA}$ $V_{CE} = 0.35\text{ V}$ $T_{amb} = -55\text{ °C}$	20	50		
f_T	Transition Frequency	$I_C = 10\text{ mA}$ $V_{CE} = 10\text{ V}$ $f = 100\text{ MHz}$	500	675		MHz
C_{CBO}	Collector-base Capacitance	$I_E = 0$ $V_{CB} = 5\text{ V}$ $f = 1\text{ MHz}$		2.3	4	pF
t_s^{**}	Storage Time	$I_C = 10\text{ mA}$ $V_{CC} = 10\text{ V}$ $I_{B1} = -I_{B2} = 10\text{ mA}$		6	13	ns
t_{on}^{**}	Turn-on Time	$I_C = 10\text{ mA}$ $V_{CC} = 3\text{ V}$ $I_{B1} = 3\text{ mA}$		9	12	ns
t_{off}^{**}	Turn-off Time	$I_C = 10\text{ mA}$ $V_{CC} = 3\text{ V}$ $I_{B1} = 3\text{ mA}$ $I_{B2} = -1.5\text{ mA}$		13	18	ns

* Pulsed : pulse duration = 300 μs , duty cycle = 1 %.

DC Current Gain.

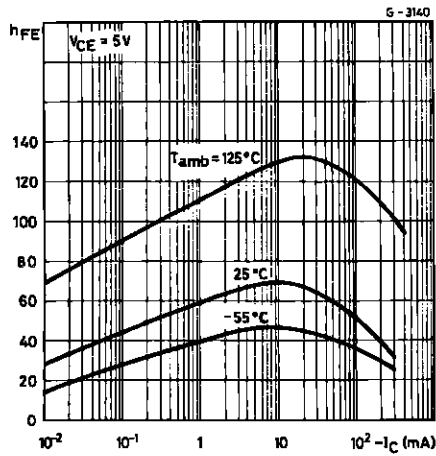

Collector-emitter Saturation Voltage.

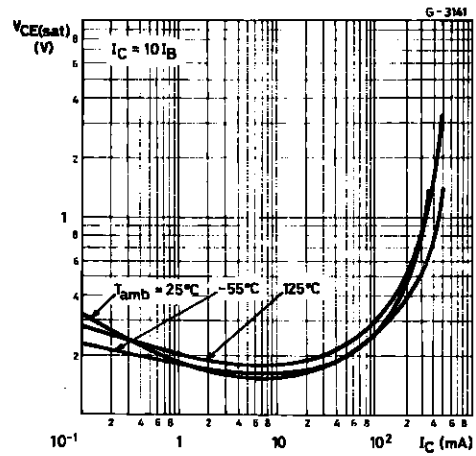

Collector-base and emitter-base capacitances.

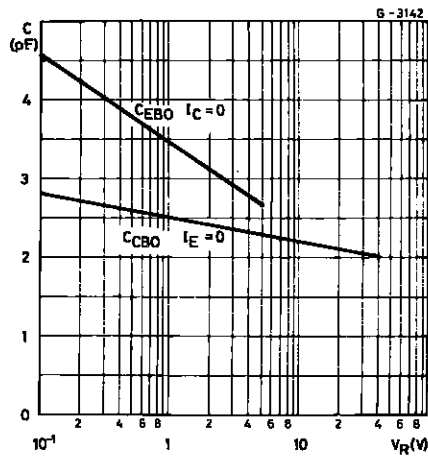

Contours of Constant Transition Frequency.

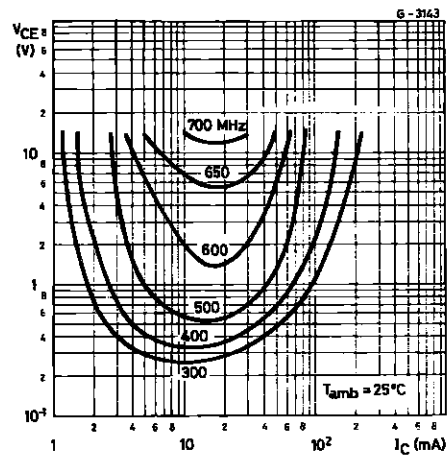

Switching Characteristics.

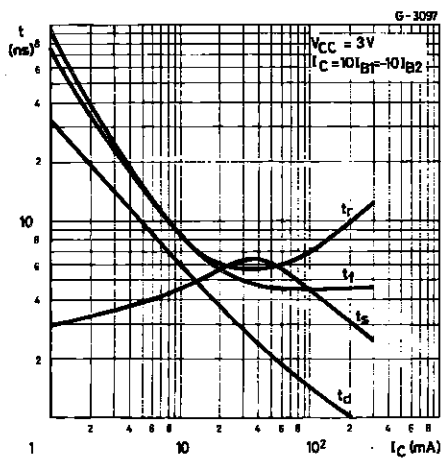

Switching Characteristics.

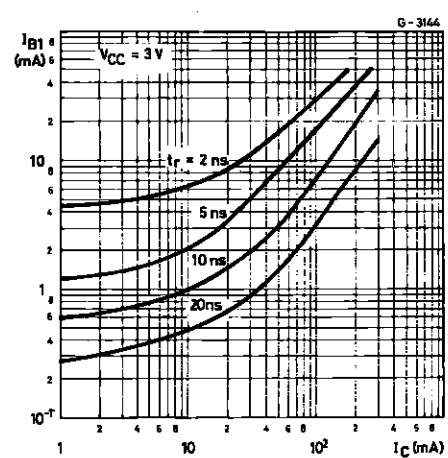

2N2369A

Test Circuit for t_s

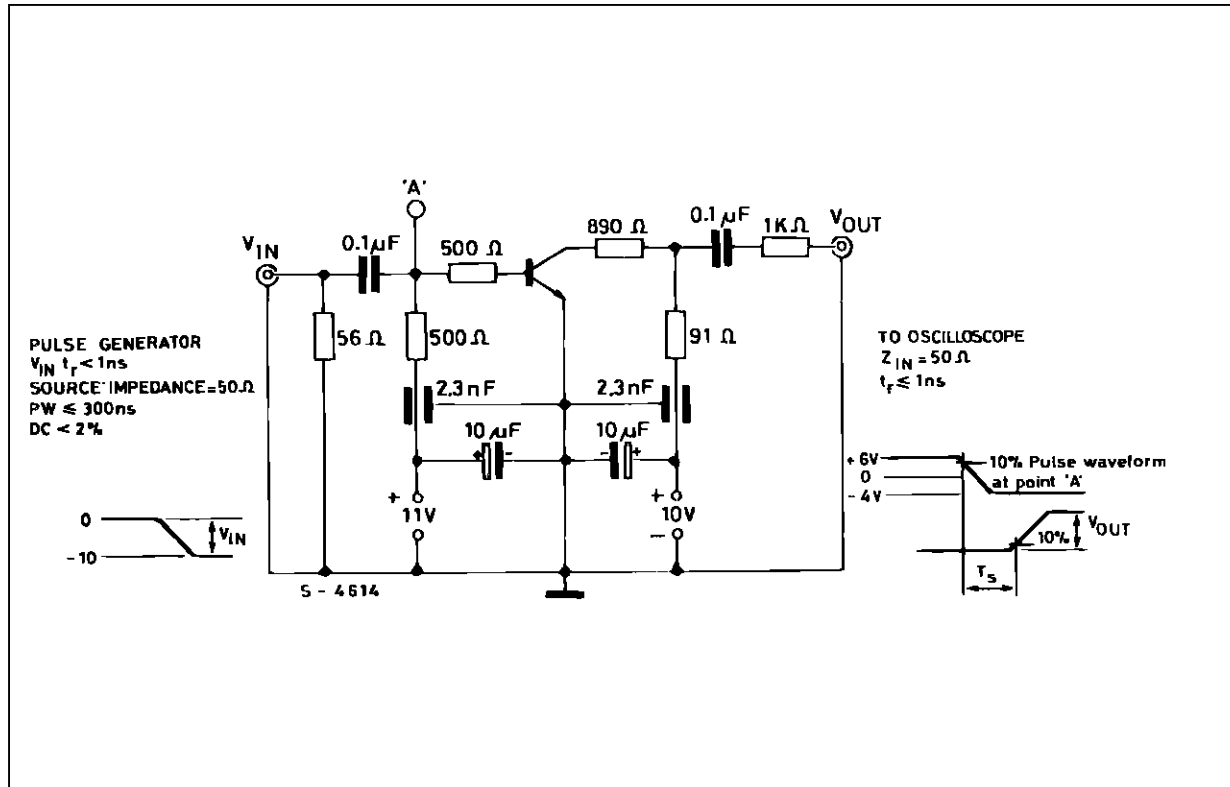

Test Circuit for t_{on} , t_{off}

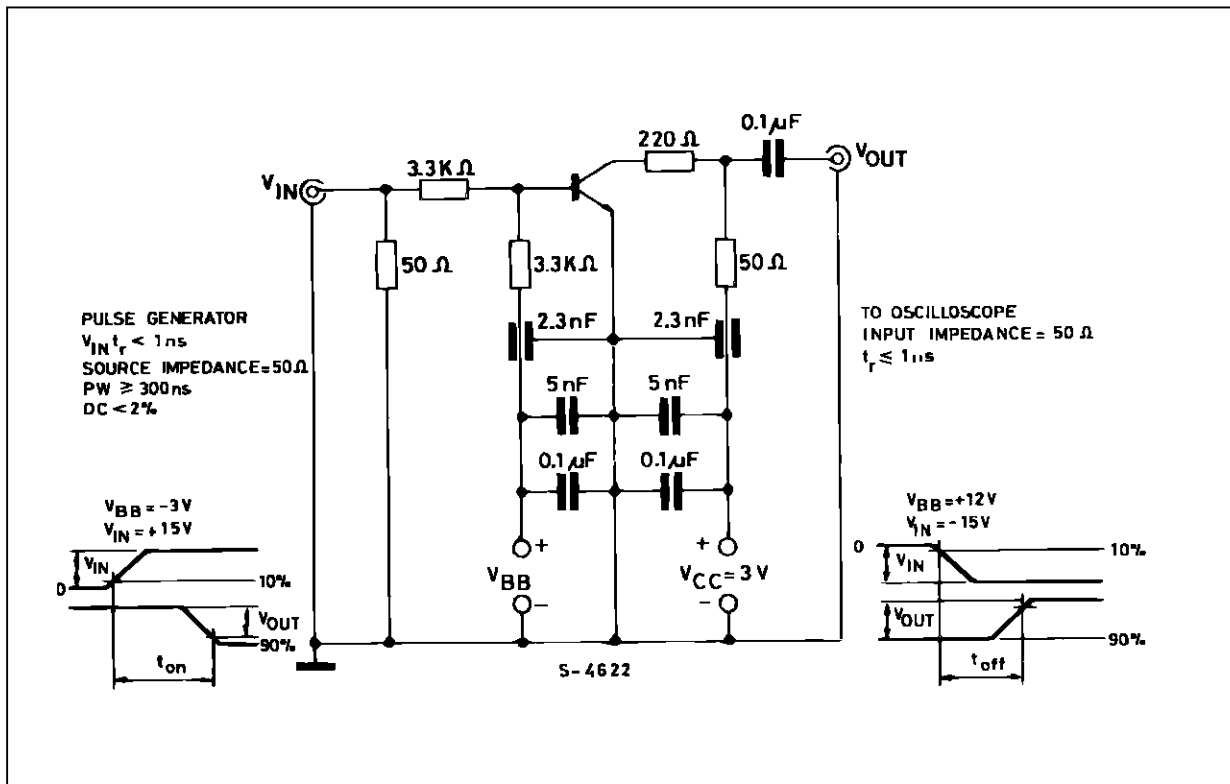

TO-18 MECHANICAL DATA

DIM.	mm			inch		
	MIN.	TYP.	MAX.	MIN.	TYP.	MAX.
A		12.7			0.500	
B			0.49			0.019
D			5.3			0.208
E			4.9			0.193
F			5.8			0.228
G	2.54			0.100		
H			1.2			0.047
I			1.16			0.045
L	45°			45°		

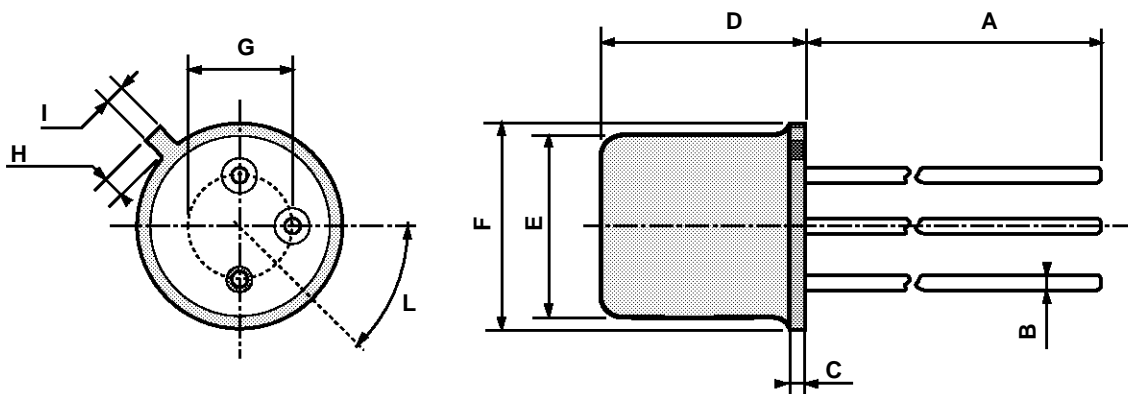

0016043

2N2369A

Information furnished is believed to be accurate and reliable. However, SGS-THOMSON Microelectronics assumes no responsibility for the consequences of use of such information nor for any infringement of patents or other rights of third parties which may result from its use. No license is granted by implication or otherwise under any patent or patent rights of SGS-THOMSON Microelectronics. Specifications mentioned in this publication are subject to change without notice. This publication supersedes and replaces all information previously supplied. SGS-THOMSON Microelectronics products are not authorized for use as critical components in life support devices or systems without express written approval of SGS-THOMSON Microelectronics.

© 1994 SGS-THOMSON Microelectronics - All Rights Reserved

SGS-THOMSON Microelectronics GROUP OF COMPANIES
Australia - Brazil - France - Germany - Hong Kong - Italy - Japan - Korea - Malaysia - Malta - Morocco - The Netherlands -
Singapore - Spain - Sweden - Switzerland - Taiwan - Thailand - United Kingdom - U.S.A

OUR CERTIFICATE

DiGi provide top-quality products and perfect service for customer worldwide through standardization, technological innovation and continuous improvement. DiGi through third-party certification, we stricly control the quality of products and services. Welcome your RFQ to

Email: Info@DiGi-Electronics.com



Tel: +00 852-30501935

RFQ Email: Info@DiGi-Electronics.com

DiGi is a global authorized distributor of electronic components.