

DSILC6-4P6 Datasheet

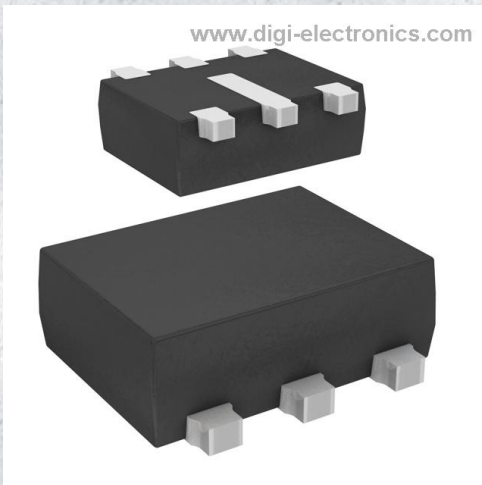

<https://www.DiGi-Electronics.com>

DiGi Electronics Part Number	DSILC6-4P6-DG
Manufacturer	STMicroelectronics
Manufacturer Product Number	DSILC6-4P6
Description	TVS DIODE 5VWM SOT666
Detailed Description	Clamp Ipp Tvs Diode Surface Mount SOT-666

This model DSILC6-4P6 is available at DiGi Electronics.

DiGi Electronics offers a global database of semiconductor and electronic component datasheets.

We welcome your inquiries regarding pricing, lead time, or other product-related questions.

 [Request a Quote](#)

 [Datasheet Search](#)



Tel: +00 852-30501935

RFQ Email: Info@DiGi-Electronics.com

DiGi is a global authorized distributor of electronic components.

Purchase and inquiry

Manufacturer Product Number:

DSILC6-4P6

Series:

DSI

Type:

Steering (Rail to Rail)

Voltage - Reverse Standoff (Typ):

5V

Voltage - Clamping (Max) @ Ipp:

-

Power - Peak Pulse:

120W

Applications:

General Purpose

Operating Temperature:

-

Package / Case:

SOT-563, SOT-666

Base Product Number:

DSILC6

Manufacturer:

STMicroelectronics

Product Status:

Active

Unidirectional Channels:

4

Voltage - Breakdown (Min):

6V

Current - Peak Pulse (10/1000µs):

-

Power Line Protection:

Yes

Capacitance @ Frequency:

2pF @ 1MHz

Mounting Type:

Surface Mount

Supplier Device Package:

SOT-666

Environmental & Export classification

RoHS Status:

ROHS3 Compliant

REACH Status:

REACH Unaffected

HTSUS:

8541.10.0080

Moisture Sensitivity Level (MSL):

1 (Unlimited)

ECCN:

EAR99



DSILC6-4xx

ESD Protection for high speed interface

Main applications

Where transient over-voltage protection in ESD sensitive equipment is required, such as:

- Computers
- Printers
- Communication systems
- Cell phone handsets and accessories
- Video equipment

Description

The **DSILC6-4xx** is a monolithic application specific discrete dedicated to ESD protection of high speed interfaces, such as USB 2.0, Ethernet, **display and camera serial interfaces (LVDS)**.

The device is ideal for applications where both reduced printed circuit board space and power absorption capability are required.

Features

Diode array topology

- 4 line protection
- 5 V V_{CC} protection
- Very low capacitance: 1 pF typ.
- Lead-free package
- RoHS compliant

Benefits

- Very low capacitance between lines to GND for optimized data integrity
- Low PCB space consumption: 2.9 mm² max for SOT-666 and 1.5 mm² max for Flip-Chip
- Cut-off frequency > 2 GHz
- High reliability offered by monolithic integration
- MDDI, SMIA, MIPI specification compliant

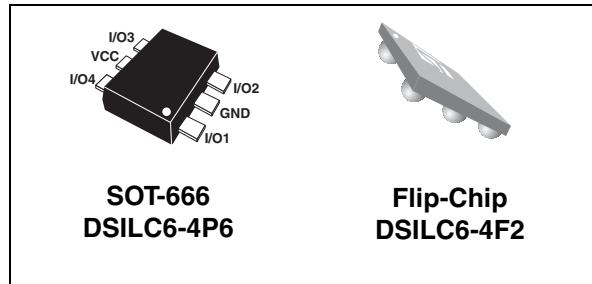

Functional diagram

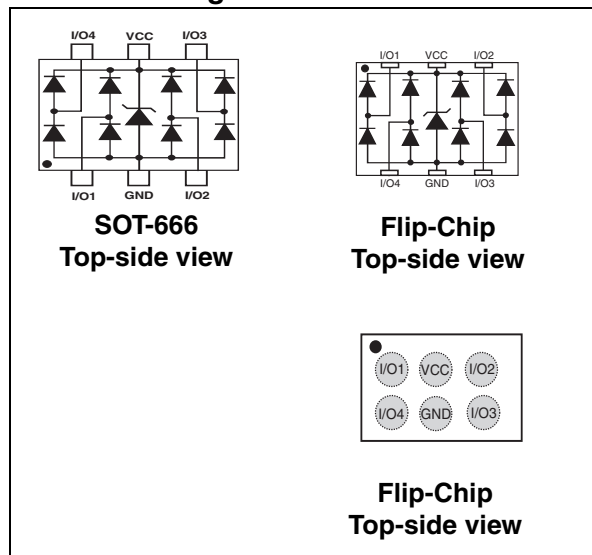

Order Code

Part Number	Marking
DSILC6-4P6	G
DSILC6-4F2	EI

Complies with the following standards:

IEC 61000-4-2 level 4:

8 kV (contact discharge)

15 kV (air discharge)

MIL STD 883G-Method 3015-7: class 3B

1 Characteristics

Table 1. Absolute ratings

Symbol	Parameter		Value	Unit	
V _{PP}	Peak pulse voltage	IEC 61000-4-2 contact discharge	8	kV	
		IEC 61000-4-2 air discharge	15		
I _{PP}	Peak pulse current	I/O to GND Pulse waveform = 8/20 μs	SOT-666	5	A
			Flip-Chip	7	
P _{PP}	Peak pulse power	I/O to GND Pulse waveform = 8/20 μs	SOT-666	90	W
			Flip-Chip	120	
T _{stg}	Storage temperature range		-55 to +150	°C	
T _j	Maximum junction temperature		125	°C	
T _L	Lead solder temperature (10 seconds duration)		260	°C	

Table 2. Electrical characteristics (T_{amb} = 25° C)

Symbol	Parameter
V _{RM}	Reverse stand-off voltage
I _{RM}	Leakage current
V _{BR}	Breakdown voltage
V _F	Forward voltage
V _{CL}	Clamping voltage
I _{PP}	Peak pulse current

Symbol	Parameter	Test Conditions	Value			Unit	
			Min	Typ	Max		
I _{RM}	Leakage current	V _{RM} = 5 V			0.5	μA	
V _{BR}	Breakdown voltage between V _{BUS} and GND	I _R = 1 mA	6			V	
V _F	Forward voltage	I _F = 10 mA			1	V	
C _{i/o-GND}	Capacitance between I/O and GND	V _{I/O} = 0 V, F = 1 MHz, V _{OSC} = 30 mV	SOT-666		2	2.5	pF
			Flip-Chip		2.5	3	
		V _{I/O} = 1.65 V, V _{CC} = 4.3 V, F = 1 MHz, V _{OSC} = 400 mV	SOT-666		1.5	1.8	
			Flip-Chip		1.8	2.0	
C _{i/o-i/o}	Capacitance between I/O	V _{I/O} = 0 V, F = 1 MHz, V _{OSC} = 30 mV	SOT-666		1.0	1.25	
			Flip-Chip		1.25	1.5	
		V _{I/O} = 1.65 V, V _{CC} = 4.3 V, F = 1 MHz, V _{OSC} = 400 mV	SOT-666		0.75	0.9	
			Flip-Chip		0.9	1.20	
ΔC _{i/o-GND}		V _{I/O} = 0 V, F = 1 MHz, V _{OSC} = 30 mV			0.06		
ΔC _{i/o-i/o}		V _{I/O} = 0 V, F = 1 MHz, V _{OSC} = 30 mV			0.05		

Figure 1. Relative variation of leakage current versus junction temperature - SOT-666 (typical values)

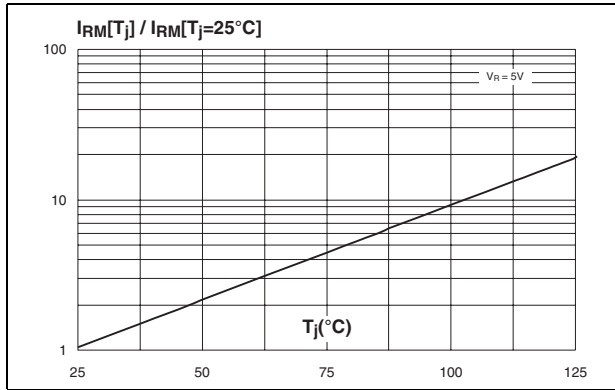

Figure 2. Relative variation of leakage current versus junction temperature Flip-Chip (typical values)

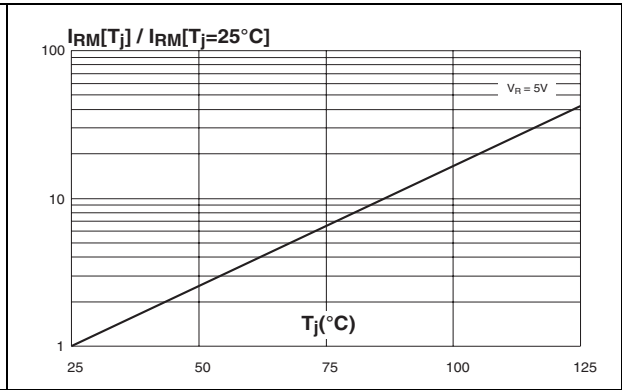

Figure 3. Remaining voltage after DSILC6-4P6 during ESD 15 kV positive surge (air discharge)

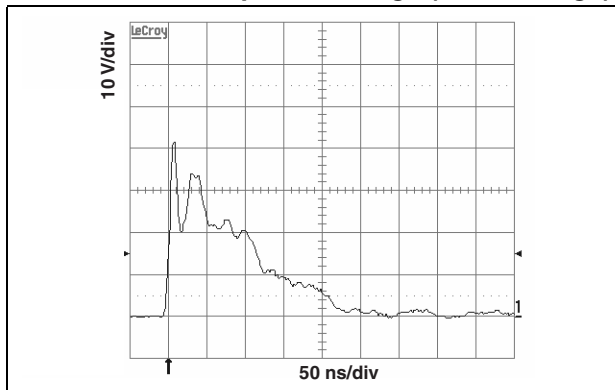

Figure 4. Remaining voltage after DSILC6-4F2 during ESD 15 kV positive surge (air discharge)

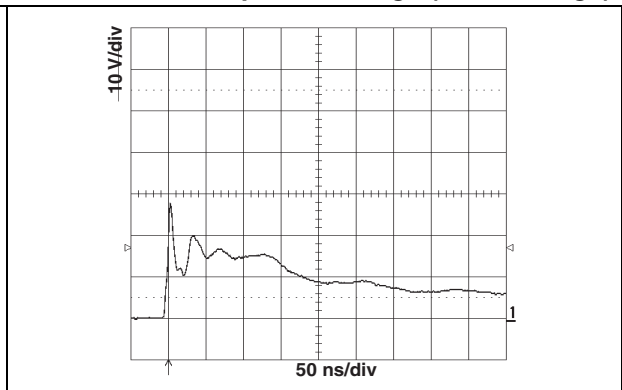

Figure 5. Remaining voltage after DSILC6-4P6 during ESD 15 kV negative surge (air discharge)

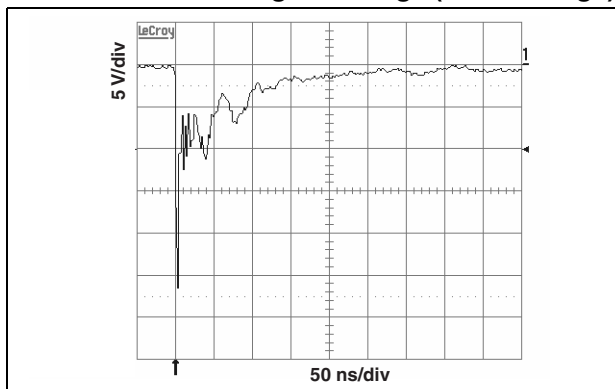

Figure 6. Remaining voltage after DSILC6-4F2 during ESD 15 kV negative surge (air discharge)

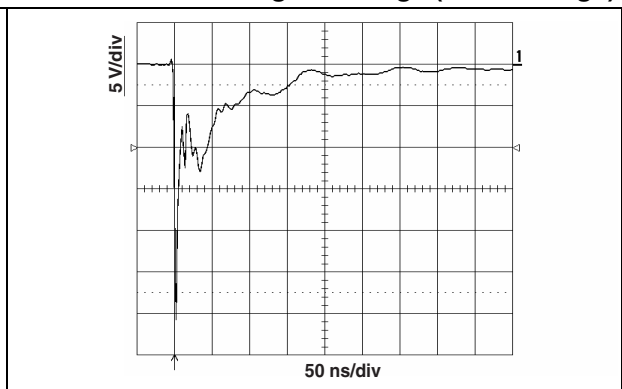

Figure 7. Frequency responses of all lines DSILC6-4P6

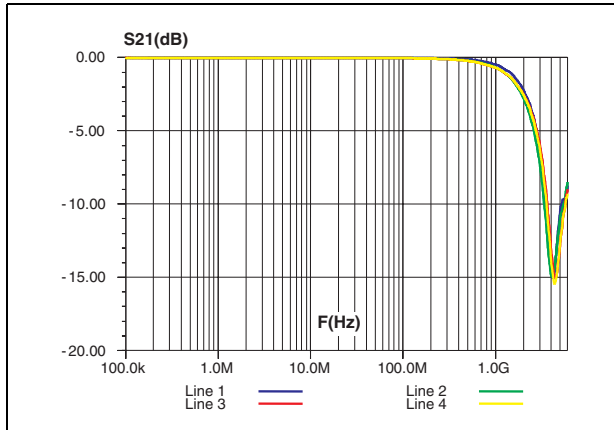

Figure 8. Frequency response of all lines DSILC6-4F2

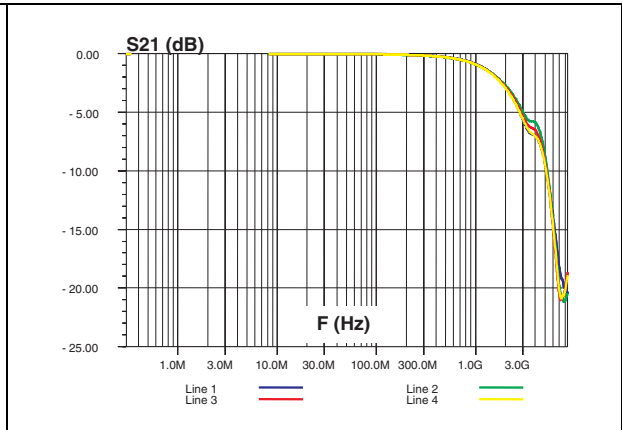

Figure 9. Crosstalk results for lines 1/2 and 1/3 DSILC6-4P6

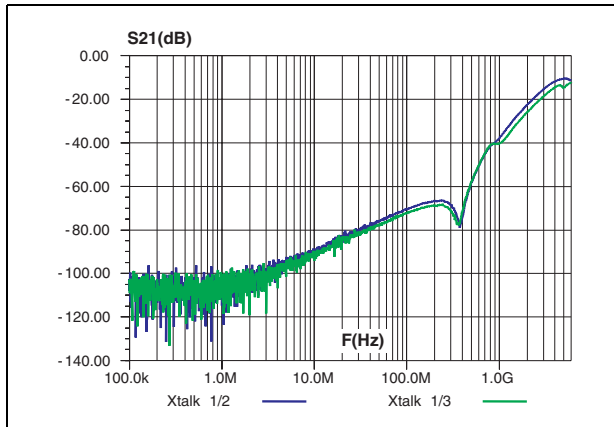
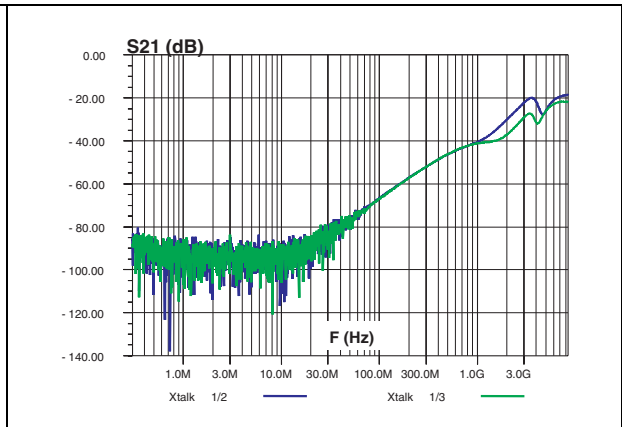
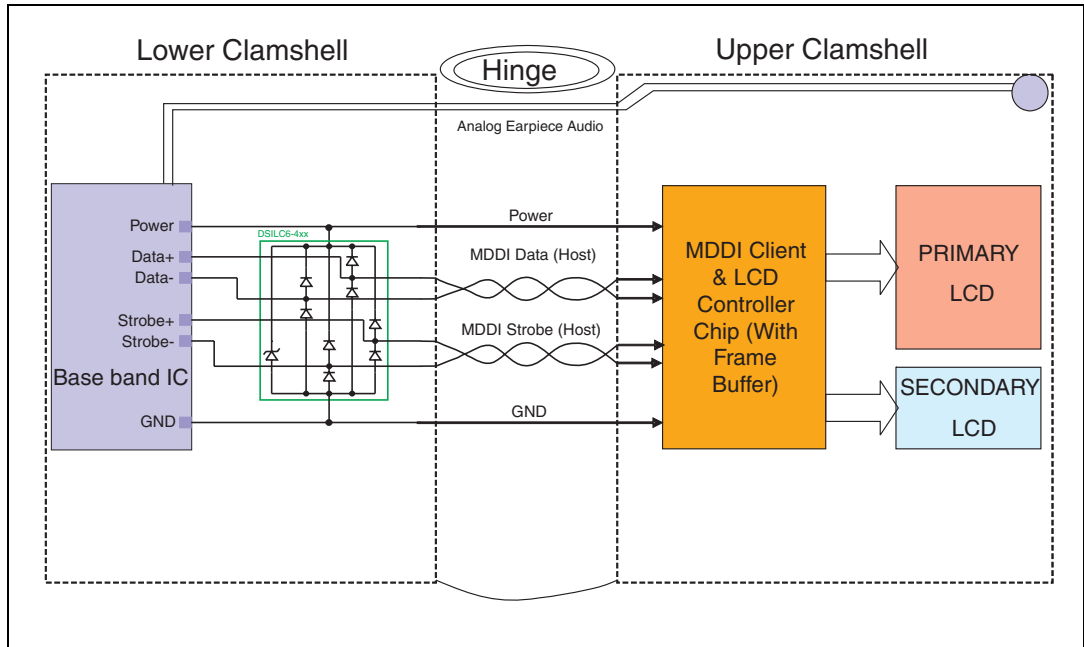

Figure 10. Crosstalk results for lines 1/2 and 1/3 DSILC6-4F2



2 Application examples

2.1 MDDI



2.2 SMIA

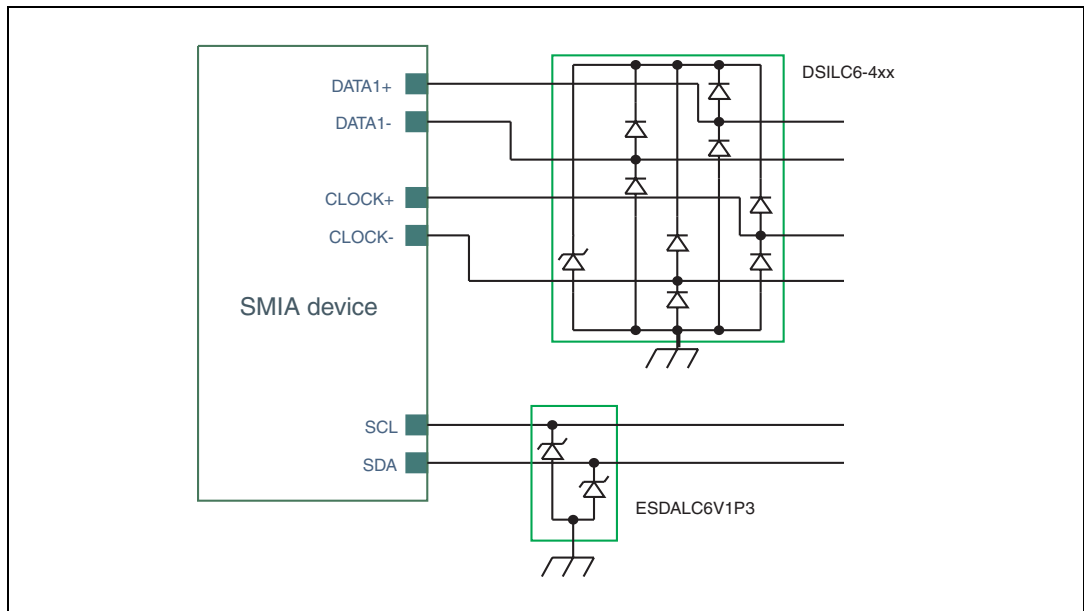

2.3 Ethernet 1 Gb

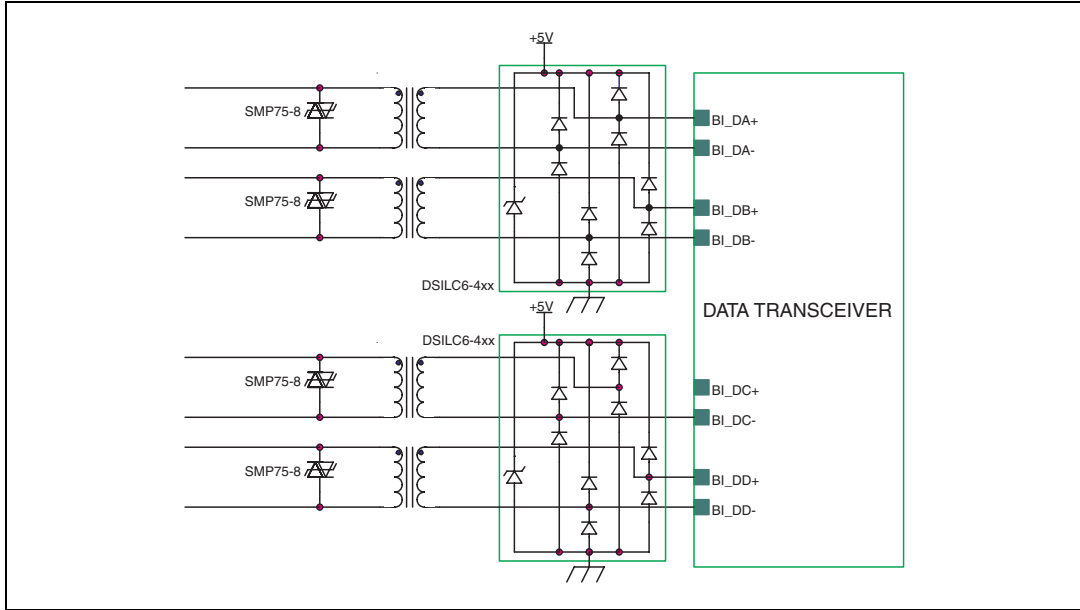

2.4 USB 2.0

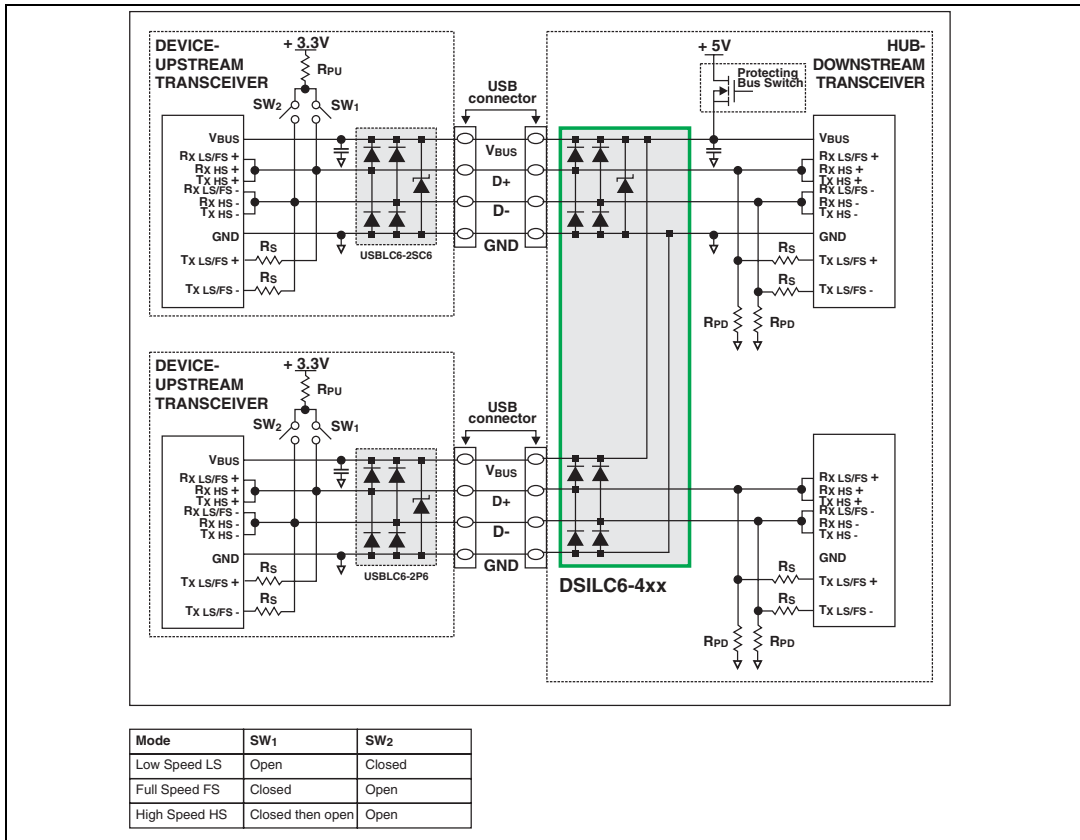

3 Ordering information scheme

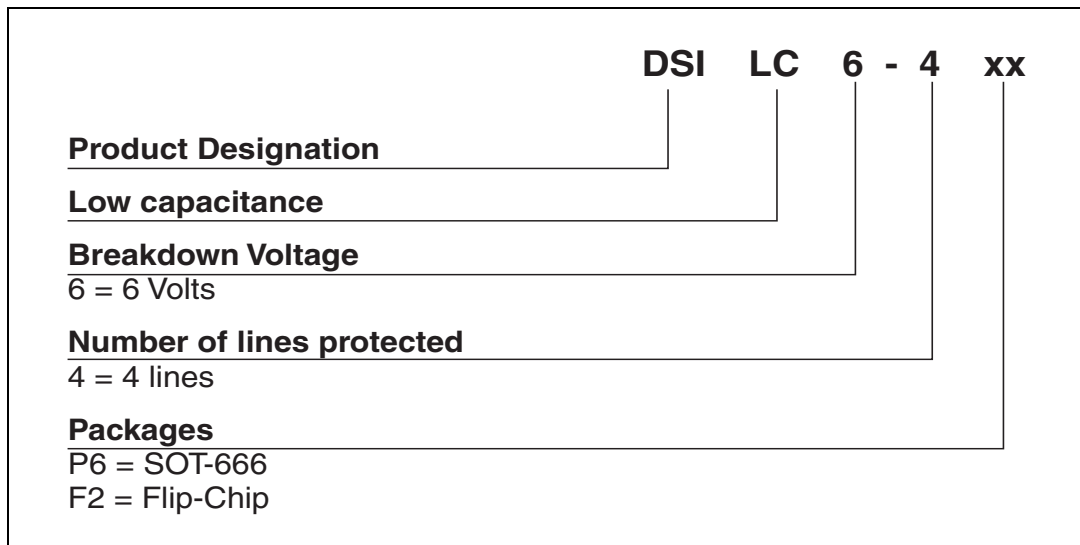

4 Package information

- Epoxy meets UL94, V0

Table 3. SOT-666 Dimensions

Ref.	Dimensions					
	Millimeters			Inches		
	Min.	Typ.	Max.	Min.	Typ.	Max.
A	0.45		0.60	0.018		0.024
A3	0.08		0.18	0.003		0.007
b	0.17		0.34	0.007		0.013
b1	0.19	0.27	0.34	0.007	0.011	0.013
D	1.50		1.70	0.059		0.067
E	1.50		1.70	0.059		0.067
E1	1.10		1.30	0.043		0.051
e		0.50			0.020	
L1		0.19			0.007	
L2	0.10		0.30	0.004		0.012
L3		0.10			0.004	

Figure 11. SOT-666 footprint

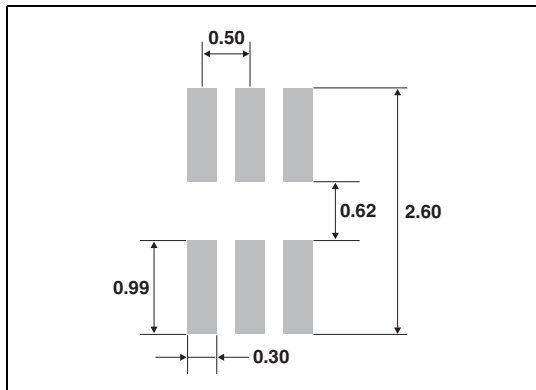

Figure 12. SOT-666 marking

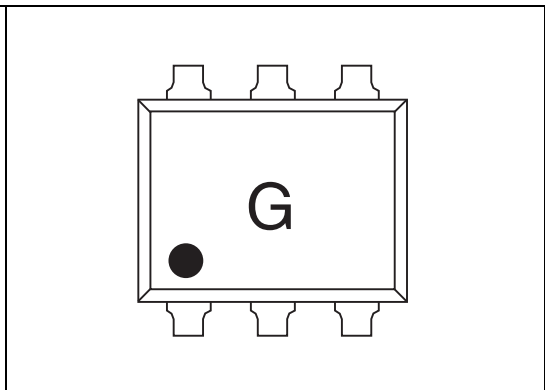

Figure 13. Flip-Chip Dimensions

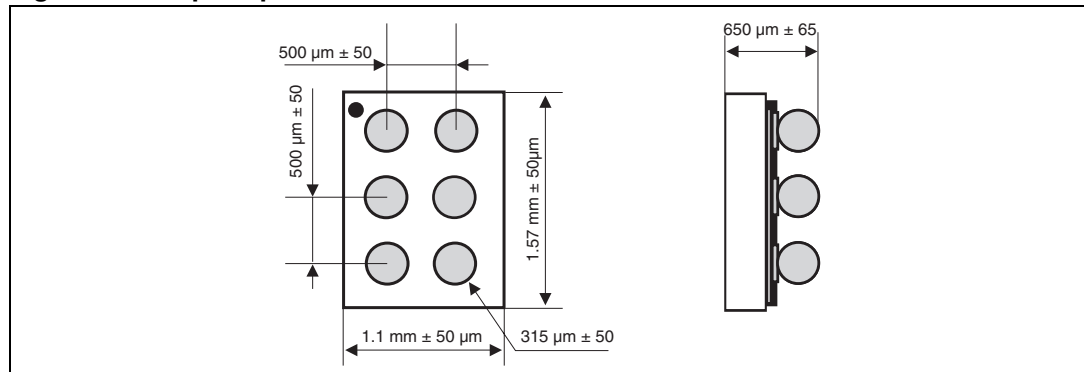

Figure 14. Flip-Chip footprint

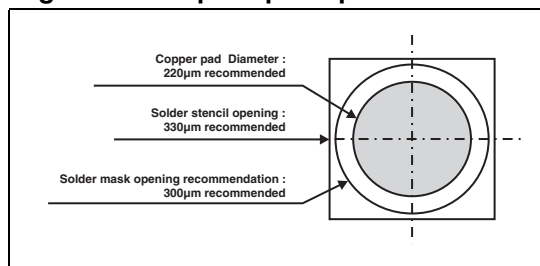

Figure 15. Flip-Chip marking

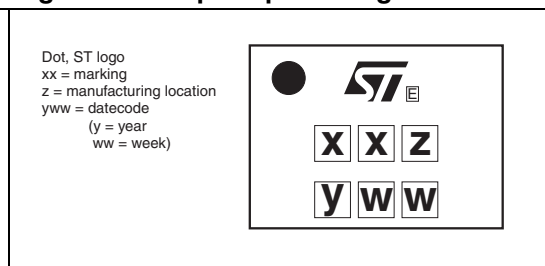
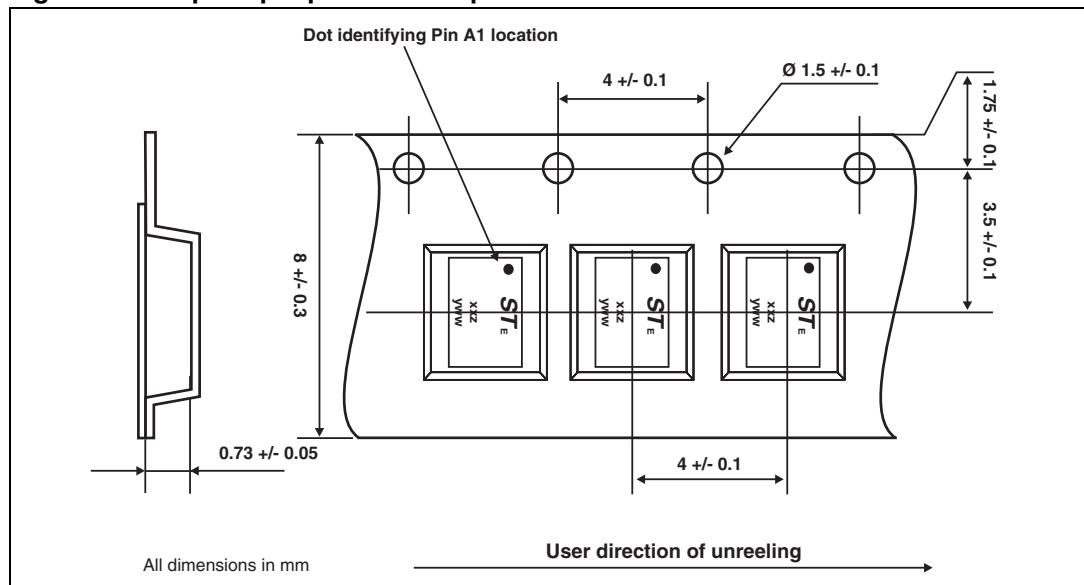

Figure 16. Flip-Chip tape and reel specifications



In order to meet environmental requirements, ST offers these devices in ECOPACK® packages. These packages have a lead-free second level interconnect. The category of second level interconnect is marked on the inner box label, in compliance with JEDEC Standard JESD97. The maximum ratings related to soldering conditions are also marked on the inner box label. ECOPACK is an ST trademark. ECOPACK specifications are available at: www.st.com.

5 Ordering information

Ordering code	Marking	Package	Weight	Base qty	Delivery mode
DSILC6-4P6	G	SOT-666	2.9 mg	3000	Tape and reel
DSILC6-4F2	EI	Flip-Chip	2.22 mg	5000	Tape and reel

6 Revision history

Date	Revision	Description of Changes
10-Aug-2006	1	Initial release.
04-Jan-2007	2	Added Flip-Chip package. Added applications examples for SMIA, Ethernet 1 Gb, and USB. Updated Tj max to 150. Added V _{RM} line in Table 2. Modified MDDI example figure.
28-May-2007	3	Modified Functional diagram on page 1 to show Top side view instead of Bump side view of DSILC64F2. Removed V _{RM} line in Table 2. Added characteristic curves specific to each package for ESD, Frequency response and Crosstalk

DSILC6-4xx

Please Read Carefully:

Information in this document is provided solely in connection with ST products. STMicroelectronics NV and its subsidiaries ("ST") reserve the right to make changes, corrections, modifications or improvements, to this document, and the products and services described herein at any time, without notice.

All ST products are sold pursuant to ST's terms and conditions of sale.

Purchasers are solely responsible for the choice, selection and use of the ST products and services described herein, and ST assumes no liability whatsoever relating to the choice, selection or use of the ST products and services described herein.

No license, express or implied, by estoppel or otherwise, to any intellectual property rights is granted under this document. If any part of this document refers to any third party products or services it shall not be deemed a license grant by ST for the use of such third party products or services, or any intellectual property contained therein or considered as a warranty covering the use in any manner whatsoever of such third party products or services or any intellectual property contained therein.

UNLESS OTHERWISE SET FORTH IN ST'S TERMS AND CONDITIONS OF SALE ST DISCLAIMS ANY EXPRESS OR IMPLIED WARRANTY WITH RESPECT TO THE USE AND/OR SALE OF ST PRODUCTS INCLUDING WITHOUT LIMITATION IMPLIED WARRANTIES OF MERCHANTABILITY, FITNESS FOR A PARTICULAR PURPOSE (AND THEIR EQUIVALENTS UNDER THE LAWS OF ANY JURISDICTION), OR INFRINGEMENT OF ANY PATENT, COPYRIGHT OR OTHER INTELLECTUAL PROPERTY RIGHT.

UNLESS EXPRESSLY APPROVED IN WRITING BY AN AUTHORIZED ST REPRESENTATIVE, ST PRODUCTS ARE NOT RECOMMENDED, AUTHORIZED OR WARRANTED FOR USE IN MILITARY, AIR CRAFT, SPACE, LIFE SAVING, OR LIFE SUSTAINING APPLICATIONS, NOR IN PRODUCTS OR SYSTEMS WHERE FAILURE OR MALFUNCTION MAY RESULT IN PERSONAL INJURY, DEATH, OR SEVERE PROPERTY OR ENVIRONMENTAL DAMAGE. ST PRODUCTS WHICH ARE NOT SPECIFIED AS "AUTOMOTIVE GRADE" MAY ONLY BE USED IN AUTOMOTIVE APPLICATIONS AT USER'S OWN RISK.

Resale of ST products with provisions different from the statements and/or technical features set forth in this document shall immediately void any warranty granted by ST for the ST product or service described herein and shall not create or extend in any manner whatsoever, any liability of ST.

ST and the ST logo are trademarks or registered trademarks of ST in various countries.

Information in this document supersedes and replaces all information previously supplied.

The ST logo is a registered trademark of STMicroelectronics. All other names are the property of their respective owners.

© 2007 STMicroelectronics - All rights reserved

STMicroelectronics group of companies

Australia - Belgium - Brazil - Canada - China - Czech Republic - Finland - France - Germany - Hong Kong - India - Israel - Italy - Japan - Malaysia - Malta - Morocco - Singapore - Spain - Sweden - Switzerland - United Kingdom - United States of America

www.st.com



OUR CERTIFICATE

DiGi provide top-quality products and perfect service for customer worldwide through standardization, technological innovation and continuous improvement. DiGi through third-party certification, we stricly control the quality of products and services. Welcome your RFQ to

Email: Info@DiGi-Electronics.com



Tel: +00 852-30501935

RFQ Email: Info@DiGi-Electronics.com

DiGi is a global authorized distributor of electronic components.