

# HDMIULC6-4SC6Y Datasheet

[www.digi-electronics.com](http://www.digi-electronics.com)

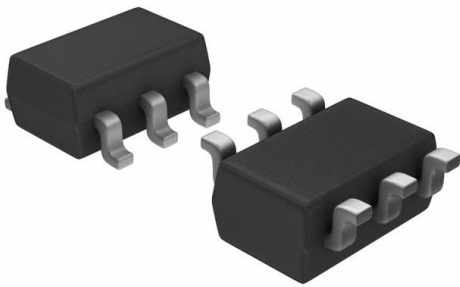

<https://www.DiGi-Electronics.com>

DiGi Electronics Part Number	HDMIULC6-4SC6Y-DG
Manufacturer	<a href="#">STMicroelectronics</a>
Manufacturer Product Number	HDMIULC6-4SC6Y
Description	TVS DIODE 5VWM 17VC SOT23-6L
Detailed Description	17V Clamp 5A (8/20µs) Ipp Tvs Diode Surface Mount SOT-23-6L

This model HDMIULC6-4SC6Y is available at DiGi Electronics.

DiGi Electronics offers a global database of semiconductor and electronic component datasheets.

We welcome your inquiries regarding pricing, lead time, or other product-related questions.

 [Request a Quote](#)

 [Datasheet Search](#)



Tel: +00 852-30501935

RFQ Email: [Info@DiGi-Electronics.com](mailto:Info@DiGi-Electronics.com)

DiGi is a global authorized distributor of electronic components.

## Purchase and inquiry

Manufacturer Product Number:

HDMIULC6-4SC6Y

Series:

HDMIY

Type:

Steering (Rail to Rail)

Voltage - Reverse Standoff (Typ):

5V

Voltage - Clamping (Max) @ Ipp:

17V

Power - Peak Pulse:

-

Applications:

Ethernet, HDMI

Operating Temperature:

-

Qualification:

AEC-Q101

Package / Case:

SOT-23-6

Base Product Number:

HDMIULC6

Manufacturer:

STMicroelectronics

Product Status:

Active

Unidirectional Channels:

4

Voltage - Breakdown (Min):

6V

Current - Peak Pulse (10/1000µs):

5A (8/20µs)

Power Line Protection:

Yes

Capacitance @ Frequency:

1pF @ 1MHz

Grade:

Automotive

Mounting Type:

Surface Mount

Supplier Device Package:

SOT-23-6L

## Environmental & Export classification

RoHS Status:

ROHS3 Compliant

REACH Status:

REACH Unaffected

HTSUS:

8541.10.0080

Moisture Sensitivity Level (MSL):

1 (Unlimited)

ECCN:

EAR99



# HDMIULC6-4SC6Y

## Automotive ultralarge bandwidth ESD protection

Datasheet – production data

### Features

- 4-line 15 kV ESD protection
- Protects  $V_{BUS}$  when applicable
- Ultrahigh bandwidth - no influence on signal rise and fall times - maximized number of signal harmonics
- Very low leakage current: 0.5  $\mu$ A max.
- Fast response time compared with varistors
- SOT23-6L package
- RoHS compliant

### Benefits

- ESD standards compliance guaranteed at device level, hence greater immunity at system level
- ESD protection of  $V_{BUS}$  when applicable.
- High efficiency due to low residual voltage when confronted by an ESD surge
- Minimized rise and fall times for maximum data integrity
- Consistent D+ / D- signal balance:
  - Ultralow impact on intra-, inter-pair skew
  - Matching high bit rate HDMI requirements and ready for future evolution
- Low PCB space occupation - 9 mm<sup>2</sup> maximum footprint
- Higher reliability offered by monolithic integration

### Complies with these standards:

- IEC 61000-4-2 level 4
  - 15 kV air discharge
  - 8 kV (and up to 15 kV) contact discharge

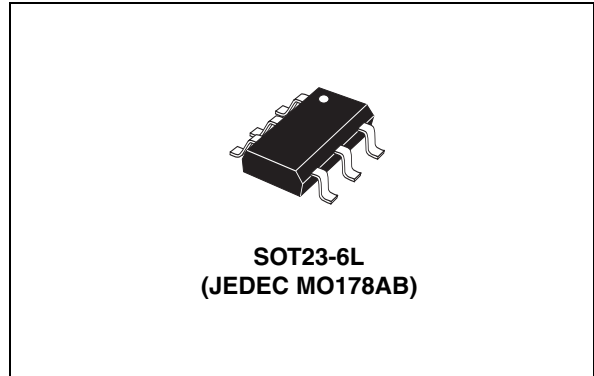

### Applications

- HDMI ports at 1.65 Gb/s and up to 3.2 Gb/s
- IEEE 1394a, b, or c up to 3.2 Gb/s
- USB 2.0 ports up to 480 Mb/s (Hi-Speed)
- Ethernet port: 10/100/1000 Mb/s
- Video line protection
- AEC-Q101 qualified

### Description

The HDMIULC6-4SC6Y is a monolithic, application specific discrete device dedicated to ESD protection of the HDMI connection. It also offers the same high level of protection for IEEE 1394a and IEEE 1394b/c, USB 2.0, Ethernet links, and video lines.

Its ultrahigh cutoff frequency (5.3 GHz) secures a high level of signal integrity. The device topology provides this integrity without compromising the complete protection of ICs against the most stringent ESD strikes.

# 1 Characteristics

Figure 1. Functional diagrams

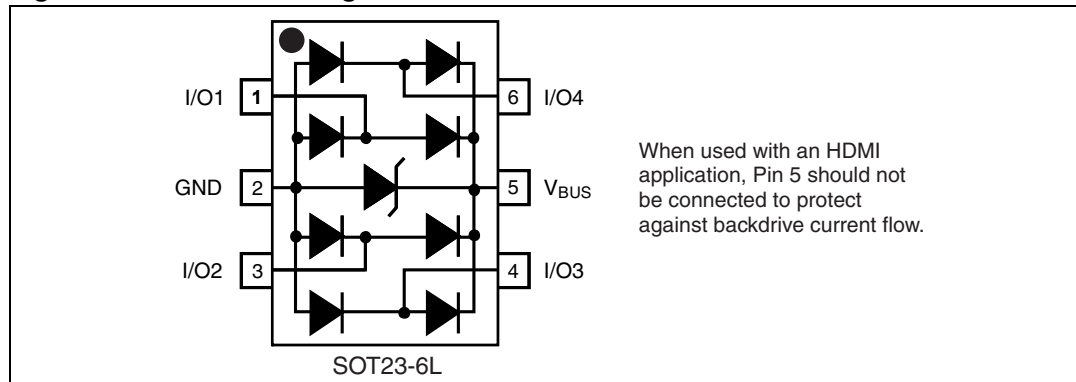

Table 1. Absolute ratings

Symbol	Parameter		Value	Unit
$V_{PP}$	Peak pulse voltage	IEC 61000-4-2 air discharge	$\pm 15$	kV
		IEC 61000-4-2 contact discharge	$\pm 15$	
		MIL STD883C-Method 3015-6	$\pm 25$	
$T_{stg}$	Storage temperature range		-55 to +150	$^{\circ}\text{C}$
$T_j$	Maximum junction temperature		125	$^{\circ}\text{C}$
$T_L$	Lead solder temperature (10 seconds duration)		260	$^{\circ}\text{C}$

Table 2. Electrical characteristics ( $T_{amb} = 25^{\circ}\text{C}$ )

Symbol	Parameter	Test conditions	Value			Unit
			Min.	Typ.	Max	
$I_{RM}$	Leakage current	$V_{RM} = 5\text{ V}$			0.5	$\mu\text{A}$
$V_{BR}$	Breakdown voltage between $V_{BUS}$ and GND	$I_R = 1\text{ mA}$	6			V
$V_{CL}$	Clamping voltage	$I_{PP} = 1\text{ A}$ , $t_p = 8/20\ \mu\text{s}$ Any I/O pin to GND			12	V
		$I_{PP} = 5\text{ A}$ , $t_p = 8/20\ \mu\text{s}$ Any I/O pin to GND			17	V
$C_{i/o-GND}$	Capacitance between I/O and GND	$V_R = 0\text{ V}$ , $F = 1\text{ MHz}$			1	pF
		$V_R = 0\text{ V}$ , $F = 825\text{ MHz}$		0.6		
$\Delta C_{i/o-GND}$	Capacitance variation between I/O and GND			0.015		
$C_{i/o-i/o}$	Capacitance between I/O	$V_R = 0\text{ V}$ , $F = 1\text{ MHz}$		0.42	0.5	pF
		$V_R = 0\text{ V}$ , $F = 825\text{ MHz}$		0.3		
$\Delta C_{i/o-i/o}$	Capacitance variation between I/O			0.007		

**Figure 2. Line capacitance versus line voltage (typical values)**

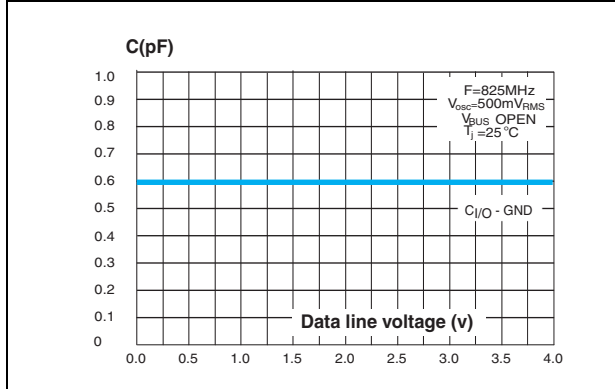

**Figure 3. Line capacitance versus frequency (typical values)**

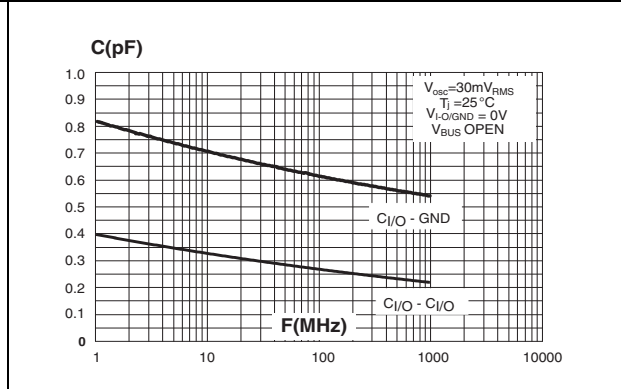

**Figure 4. Relative variation of leakage current versus junction temperature (typical values)**

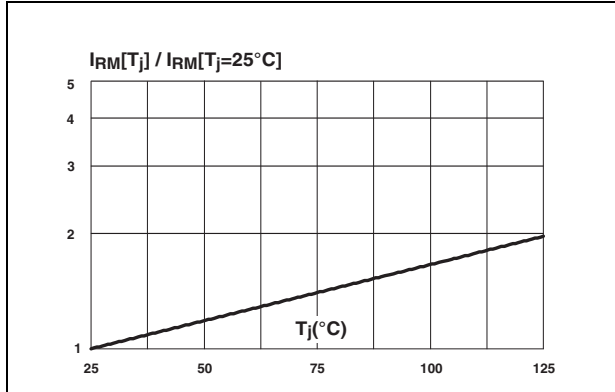

**Figure 5. Frequency response**

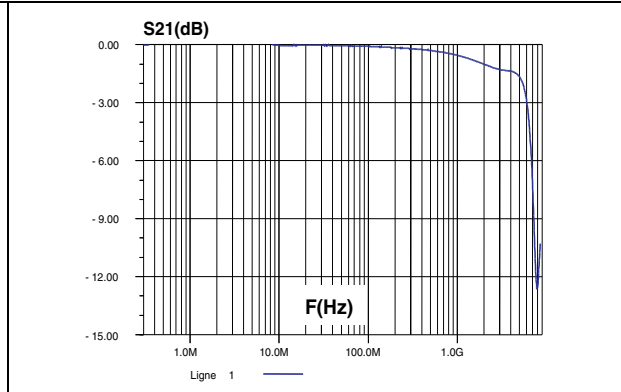

## 2 Application examples

Figure 6. HDMI digital single link application using HDMIULC6-4SC6Y

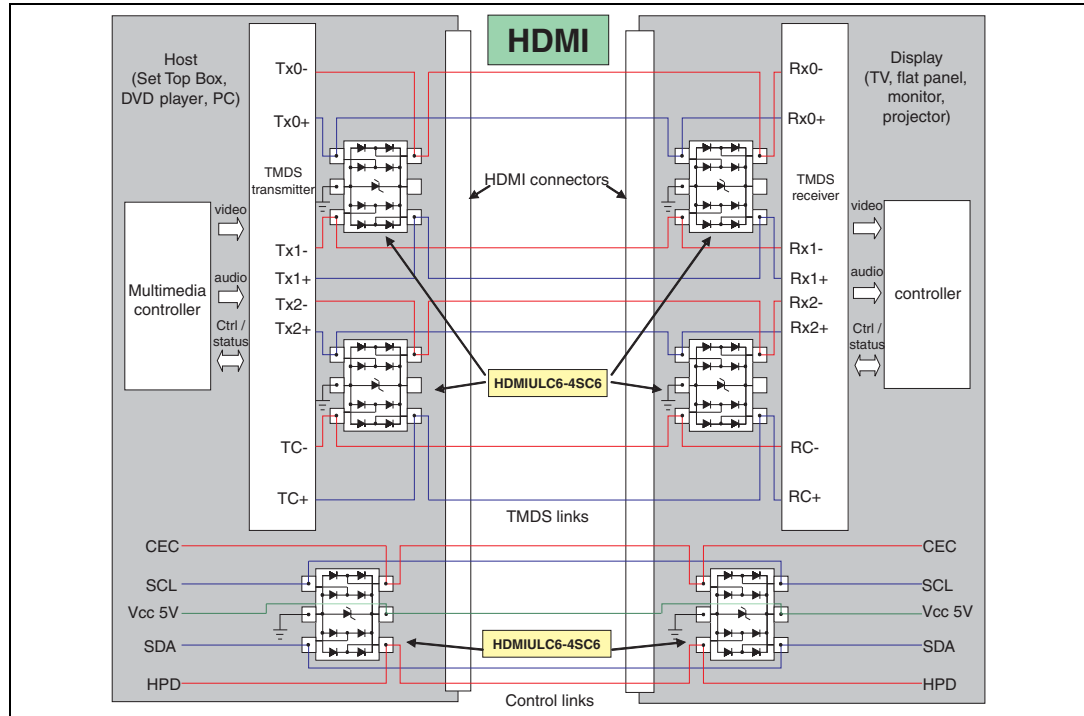
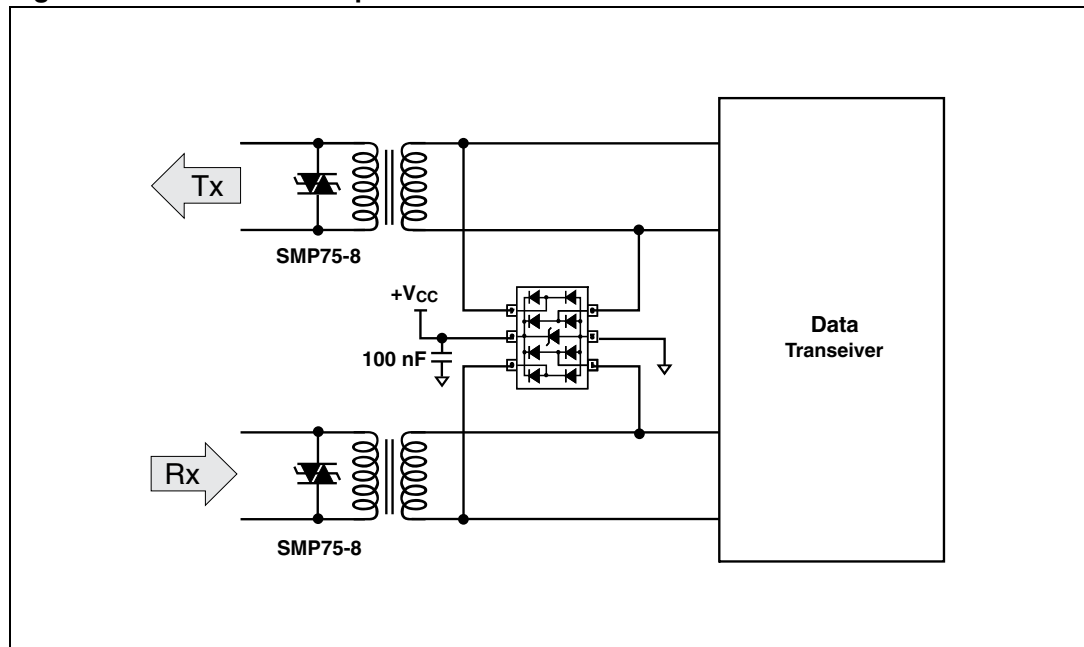

Figure 7. T1/E1/Ethernet protection



## 2.1 PCB layout considerations

For HDMI applications,  $V_{CC}$  should not be connected. In this case the capacitor C in [Figure 8](#) is not needed.

**Figure 8. PCB layout considerations ( $V_{CC}$  connection is application dependent)**

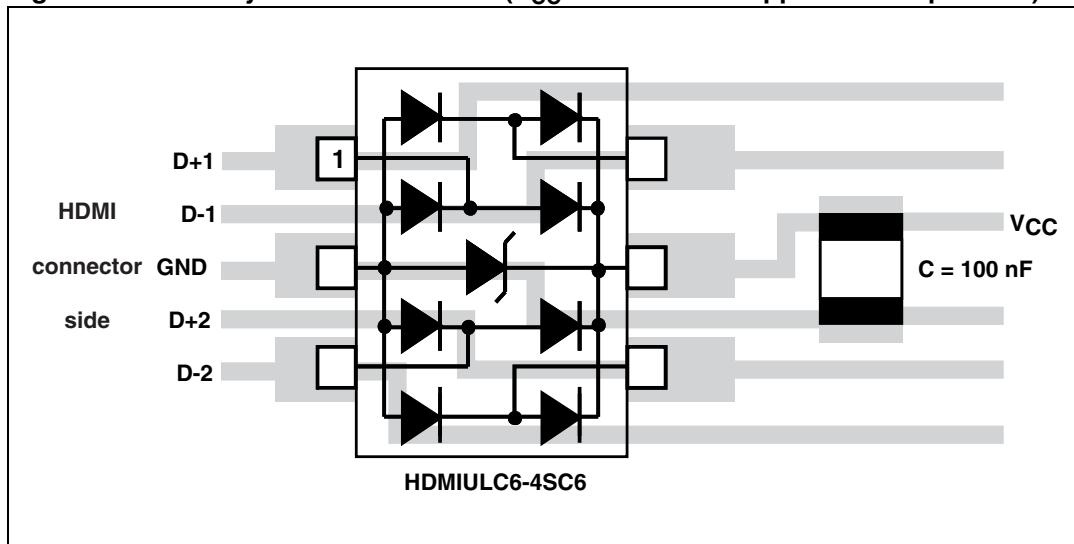

A differential impedance of  $100\ \Omega$  must be respected in the layout. Both lines of the differential pair should have the same length.

**Figure 9. SOT23-6L Footprint dimensions (in mm)**

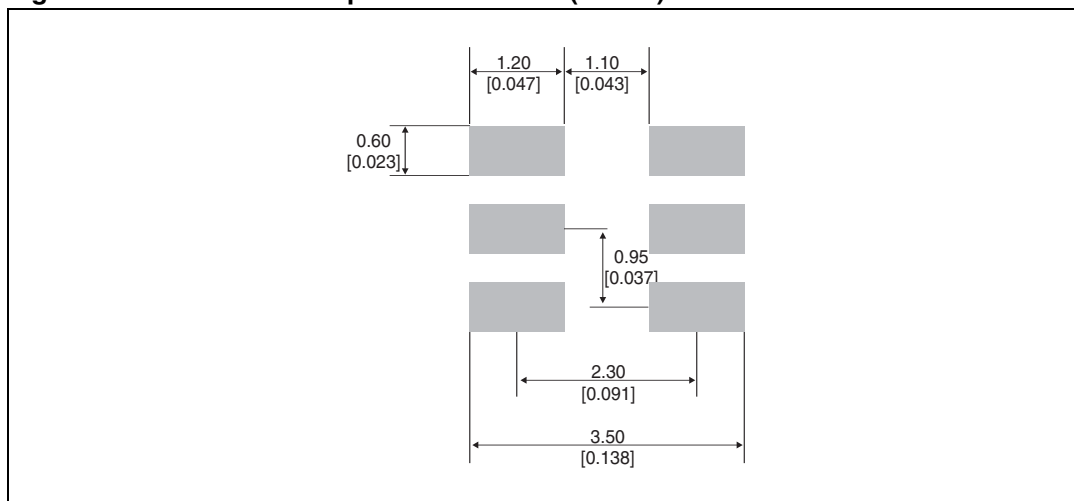

## 3 Technical information

### 3.1 Surge protection

The HDMIULC6-4SC6Y is particularly optimized to perform ESD surge protection based on the rail to rail topology.

The clamping voltage  $V_{CL}$  can be calculated as follows

- $V_{CL+} = V_{Transil} + V_F$  for positive surges
- $V_{CL-} = -V_F$  for negative surges

with:  $V_F = V_T + R_d \cdot I_p$

( $V_F$  forward drop voltage) / ( $V_T$  forward drop threshold voltage)

and  $V_{Transil} = V_{BR} + R_{d\_Transil} \cdot I_p$

#### Calculation example

We assume that the value of the dynamic resistance of the clamping diode is typically:  $R_d = 0.5 \Omega$  and  $V_T = 1.1 V$ .

We assume that the value of the dynamic resistance of the Transil diode is typically  $R_{d\_Transil} = 0.5 \Omega$  and  $V_{BR} = 6.1 V$

For an IEC 61000-4-2 surge Level 4 (Contact Discharge:  $V_g = 8 kV$ ,  $R_g = 330 \Omega$ ),  $V_{BUS} = +5 V$ , and, in first approximation, we assume that:  $I_p = V_g / R_g = 24 A$ .

We find:

- $V_{CL+} = +31.2 V$
- $V_{CL-} = -13.1 V$

*Note: The calculations do not take into account phenomena due to parasitic inductances.*

### 3.2 Surge protection application example

If we consider that the connections from the pin  $V_{BUS}$  to  $V_{CC}$ , from I/O to data line, and from GND to PCB GND plane are two tracks 10 mm long and 0.5 mm wide, we can assume that the parasitic inductances,  $L_{VBUS}$ ,  $L_{I/O}$ , and  $L_{GND}$ , of these tracks are about 6 nH. So when an IEC 61000-4-2 surge occurs on the data line, due to the rise time of this spike ( $t_r = 1 ns$ ), the voltage  $V_{CL}$  has an extra value equal to  $L_{I/O} \cdot di/dt + L_{GND} \cdot di/dt$ .

The  $di/dt$  is calculated as:  $di/dt = I_p/t_r = 24 A/ns$  for an IEC 61000-4-2 surge level 4 (contact discharge  $V_g = 8 kV$ ,  $R_g = 330 \Omega$ )

The over voltage due to the parasitic inductances is:

$$L_{I/O} \cdot di/dt = L_{GND} \cdot di/dt = 6 \times 24 = 144 V$$

By taking into account the effect of these parasitic inductances due to unsuitable layout, the clamping voltage will be:

- $V_{CL+} = +31.2 + 144 + 144 = 319.2 V$
- $V_{CL-} = -13.1 - 144 - 144 = -301.1 V$

We can reduce as much as possible these phenomena with simple layout optimization.

It's the reason why some recommendations have to be followed (see [Section 3.3: How to ensure good ESD protection](#)).

**Figure 10. ESD behavior: parasitic phenomena due to unsuitable layout**

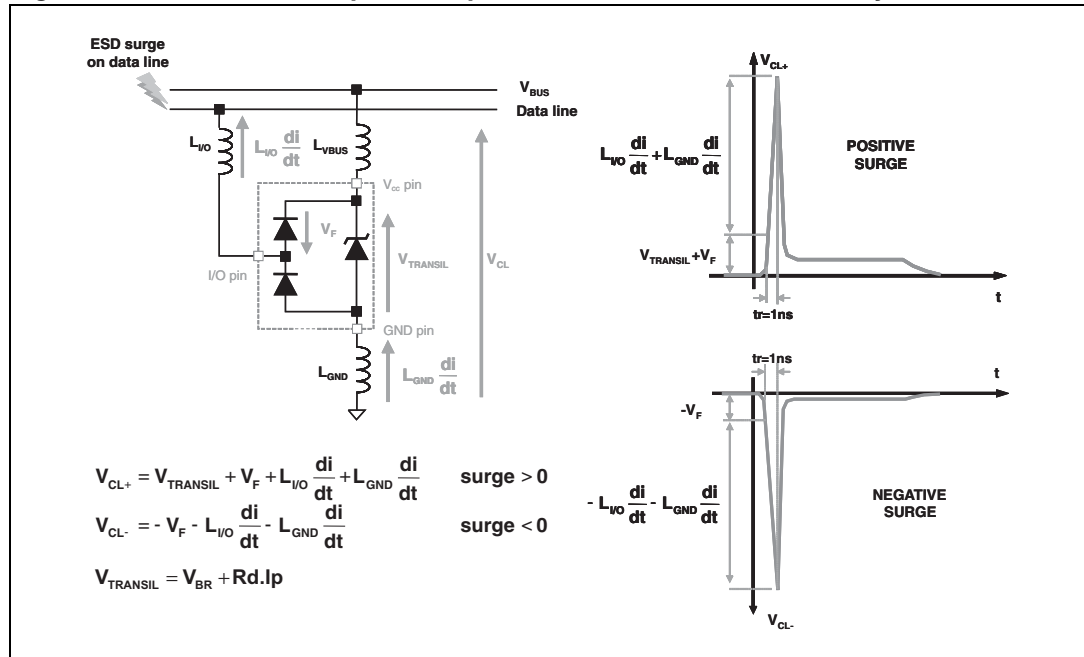

### 3.3 How to ensure good ESD protection

While the HDMIULC6-4SC6Y provides a high immunity to ESD surge, an efficient protection depends on the layout of the board. In the same way, with the rail to rail topology, the track from data lines to I/O pins, from  $V_{CC}$  to  $V_{BUS}$  pin, and from GND plane to GND pin must be as short as possible to avoid over voltages due to parasitic phenomena (see [Figure 10](#) and [Figure 11](#) for layout considerations).

**Figure 11. ESD behavior: layout optimization**

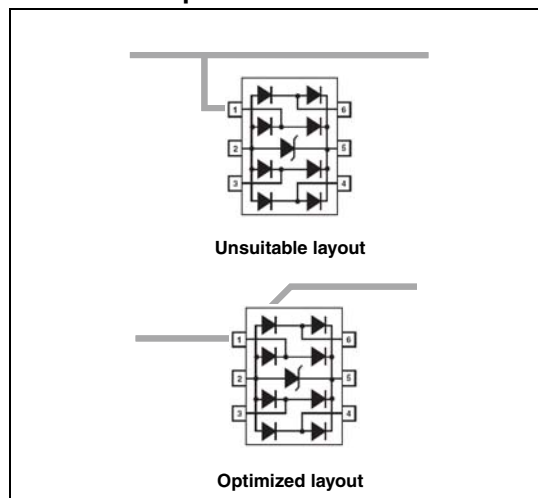

**Figure 12. ESD behavior: measurement conditions**

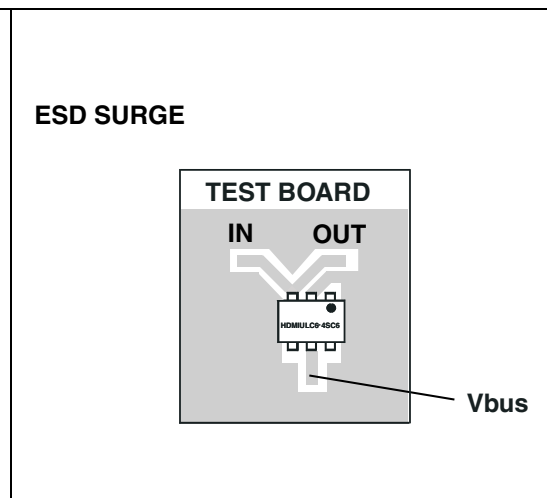

Figure 13.

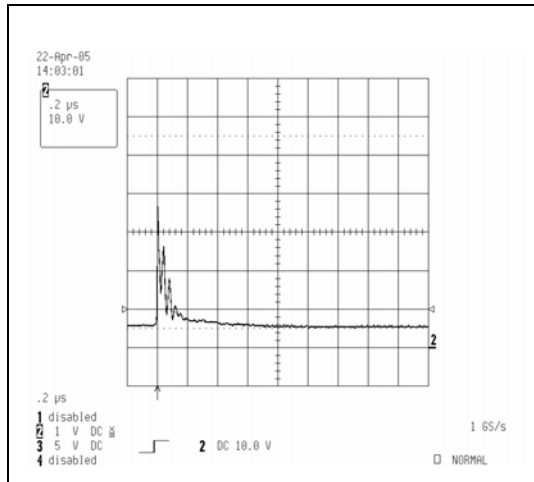
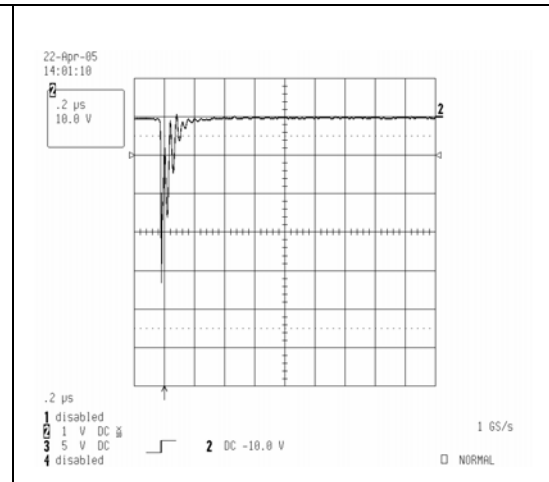

Figure 14.



Note: The measurements have been done with the HDMIULC6-4SC6Y in open circuit.

## Important:

An important precaution to take is to put the protection device as close as possible to the disturbance source (generally the connector).

## 3.4 Crosstalk behavior

Figure 15. Crosstalk phenomena

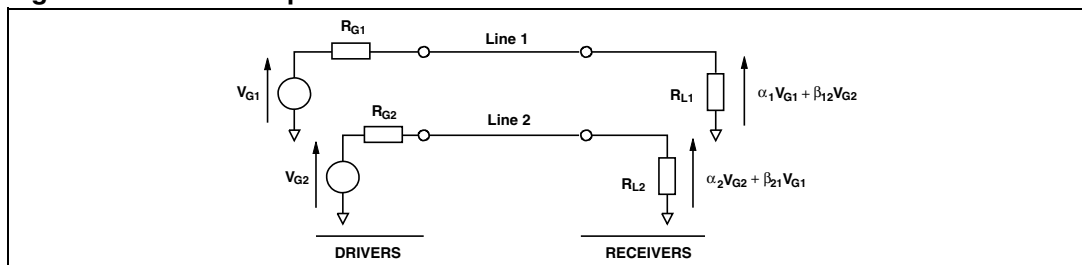

The crosstalk phenomena is due to the coupling between 2 lines. The coupling factor ( $\beta_{12}$  or  $\beta_{21}$ ) increases when the gap across lines decreases, particularly in silicon dice. In the example above the expected signal on load  $R_{L2}$  is  $\alpha_2 V_{G2}$ , in fact the real voltage at this point has got an extra value  $\beta_{21} V_{G1}$ . This part of the  $V_{G1}$  signal represents the effect of the crosstalk phenomenon of the line 1 on the line 2. This phenomenon has to be taken into account when the drivers impose fast digital data or high frequency analog signals in the disturbing line. The perturbed line will be more affected if it works with low voltage signal or high load impedance (few  $k\Omega$ ).

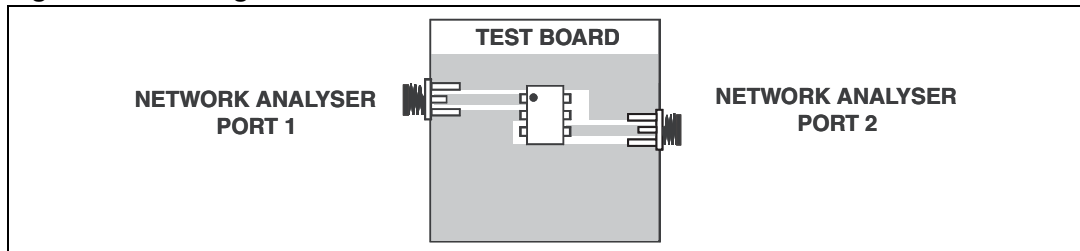
**Figure 16. Analog crosstalk measurements**

[Figure 16](#) gives the measurement circuit for the analog application. In usual frequency range of analog signals (up to 240 MHz) the effect on disturbed line is less than -45 dB (see [Figure 17](#)).

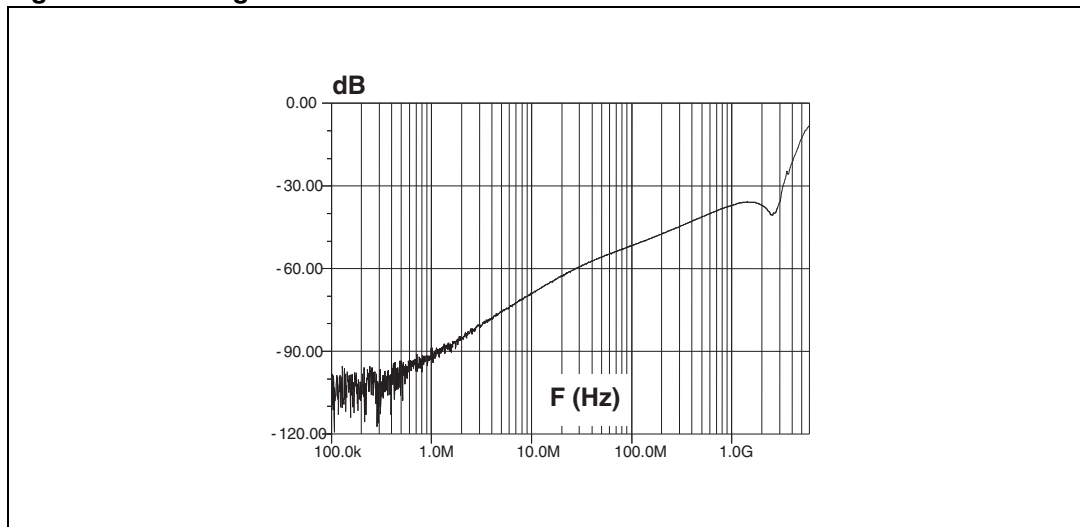
**Figure 17. Analog crosstalk results**

As the HDMIULC6-4SC6Y is designed to protect high speed data lines, it must ensure a good transmission of operating signals. The frequency response ([Figure 5](#).) gives attenuation information and shows that the HDMIULC6-4SC6Y is well suitable for data line transmission up to 3.2 Gb/s.

## 4 Package information

- Epoxy meets UL94, V0
- Lead-free package

In order to meet environmental requirements, ST offers these devices in different grades of ECOPACK® packages, depending on their level of environmental compliance. ECOPACK® specifications, grade definitions and product status are available at: [www.st.com](http://www.st.com). ECOPACK® is an ST trademark.

**Table 3. SOT23-6L dimensions**

Ref.	Dimensions					
	Millimeters			Inches		
	Min.	Typ.	Max.	Min.	Typ.	Max.
A	0.90		1.45	0.035		0.057
A1	0		0.15	0		0.006
A2	0.90		1.30	0.035		0.051
b	0.30		0.50	0.012		0.020
c	0.09		0.20	0.004		0.008
D	2.80		3.05	0.11		0.118
E	1.50		1.75	0.059		0.069
e		0.95			0.037	
H	2.60		3.00	0.102		0.118
L	0.30		0.60	0.012		0.024
θ	0°		10°	0°		10°

**Figure 18. Footprint (dimensions in mm)**

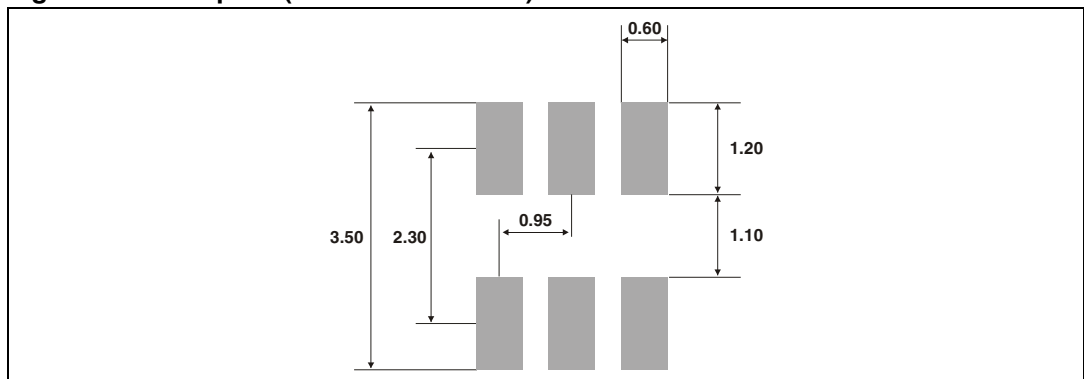

## 5 Ordering information

Table 4. Ordering information

Order code	Marking	Package	Weight	Base qty	Delivery mode
HDMIULC6-4SC6Y	DL4Y	SOT23-6L	16.7 mg	3000	Tape and reel

## 6 Revision history

Table 5. Document revision history

Date	Revision	Changes
24-May-2011	1	First issue.
06-Sep-2012	2	Updated dimension A1 max., b min. and L min. in <a href="#">Table 3</a> .

**Please Read Carefully:**

Information in this document is provided solely in connection with ST products. STMicroelectronics NV and its subsidiaries ("ST") reserve the right to make changes, corrections, modifications or improvements, to this document, and the products and services described herein at any time, without notice.

All ST products are sold pursuant to ST's terms and conditions of sale.

Purchasers are solely responsible for the choice, selection and use of the ST products and services described herein, and ST assumes no liability whatsoever relating to the choice, selection or use of the ST products and services described herein.

No license, express or implied, by estoppel or otherwise, to any intellectual property rights is granted under this document. If any part of this document refers to any third party products or services it shall not be deemed a license grant by ST for the use of such third party products or services, or any intellectual property contained therein or considered as a warranty covering the use in any manner whatsoever of such third party products or services or any intellectual property contained therein.

**UNLESS OTHERWISE SET FORTH IN ST'S TERMS AND CONDITIONS OF SALE ST DISCLAIMS ANY EXPRESS OR IMPLIED WARRANTY WITH RESPECT TO THE USE AND/OR SALE OF ST PRODUCTS INCLUDING WITHOUT LIMITATION IMPLIED WARRANTIES OF MERCHANTABILITY, FITNESS FOR A PARTICULAR PURPOSE (AND THEIR EQUIVALENTS UNDER THE LAWS OF ANY JURISDICTION), OR INFRINGEMENT OF ANY PATENT, COPYRIGHT OR OTHER INTELLECTUAL PROPERTY RIGHT.**

**UNLESS EXPRESSLY APPROVED IN WRITING BY TWO AUTHORIZED ST REPRESENTATIVES, ST PRODUCTS ARE NOT RECOMMENDED, AUTHORIZED OR WARRANTED FOR USE IN MILITARY, AIR CRAFT, SPACE, LIFE SAVING, OR LIFE SUSTAINING APPLICATIONS, NOR IN PRODUCTS OR SYSTEMS WHERE FAILURE OR MALFUNCTION MAY RESULT IN PERSONAL INJURY, DEATH, OR SEVERE PROPERTY OR ENVIRONMENTAL DAMAGE. ST PRODUCTS WHICH ARE NOT SPECIFIED AS "AUTOMOTIVE GRADE" MAY ONLY BE USED IN AUTOMOTIVE APPLICATIONS AT USER'S OWN RISK.**

Resale of ST products with provisions different from the statements and/or technical features set forth in this document shall immediately void any warranty granted by ST for the ST product or service described herein and shall not create or extend in any manner whatsoever, any liability of ST.

ST and the ST logo are trademarks or registered trademarks of ST in various countries.

Information in this document supersedes and replaces all information previously supplied.

The ST logo is a registered trademark of STMicroelectronics. All other names are the property of their respective owners.

© 2012 STMicroelectronics - All rights reserved

STMicroelectronics group of companies

Australia - Belgium - Brazil - Canada - China - Czech Republic - Finland - France - Germany - Hong Kong - India - Israel - Italy - Japan - Malaysia - Malta - Morocco - Philippines - Singapore - Spain - Sweden - Switzerland - United Kingdom - United States of America

[www.st.com](http://www.st.com)

## OUR CERTIFICATE

DiGi provide top-quality products and perfect service for customer worldwide through standardization, technological innovation and continuous improvement. DiGi through third-party certification, we stricly control the quality of products and services. Welcome your RFQ to

Email: [Info@DiGi-Electronics.com](mailto:Info@DiGi-Electronics.com)



Tel: +00 852-30501935

RFQ Email: [Info@DiGi-Electronics.com](mailto:Info@DiGi-Electronics.com)

DiGi is a global authorized distributor of electronic components.