

L9788TR Datasheet

www.digi-electronics.com

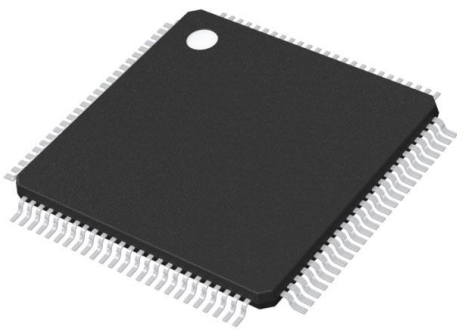

<https://www.DiGi-Electronics.com>

DiGi Electronics Part Number	L9788TR-DG
Manufacturer	STMicroelectronics
Manufacturer Product Number	L9788TR
Description	MULTIFUNCTION IC FOR AUTOMOTIVE
Detailed Description	PMIC 100-LQFP-EP (14x14)

This model L9788TR is available at DiGi Electronics.

DiGi Electronics offers a global database of semiconductor and electronic component datasheets.

We welcome your inquiries regarding pricing, lead time, or other product-related questions.

 [Request a Quote](#)

 [Datasheet Search](#)



Tel: +00 852-30501935

RFQ Email: Info@DiGi-Electronics.com

DiGi is a global authorized distributor of electronic components.

Purchase and inquiry

Manufacturer Product Number:

L9788TR

Series:

-

Applications:

-

Voltage - Supply:

-

Grade:

Automotive

Mounting Type:

Surface Mount

Supplier Device Package:

100-LQFP-EP (14x14)

Manufacturer:

STMicroelectronics

Product Status:

Active

Current - Supply:

-

Operating Temperature:

-40°C ~ 125°C

Qualification:

AEC-Q100

Package / Case:

100-LQFP Exposed Pad

Base Product Number:

L9788

Environmental & Export classification

RoHS Status:

ROHS3 Compliant

REACH Status:

REACH Unaffected

HTSUS:

8542.39.0001

Moisture Sensitivity Level (MSL):

3 (168 Hours)

ECCN:

EAR99

**L9788**

Multifunction IC for automotive engine management system

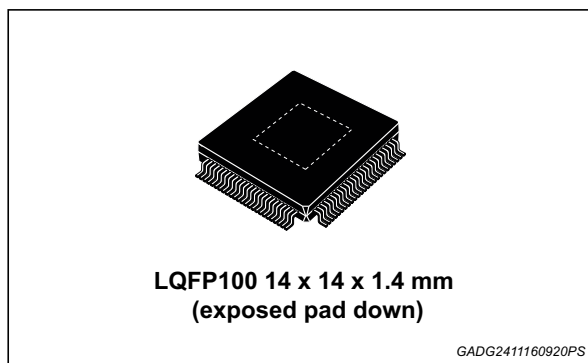
Data brief

Features



- AEC-Q100 qualified
- Engineered for ISO26262 compliant system
- 1 pre boost regulator and 1 pre buck regulator
- 1 linear 5 V regulator with 1 A output current
- 3 independent self-protection 5 V tracking regulator with 150 mA output.
- 1 input voltage pin for monitor external tracking.
- Coordinated soft start-up of all regulators
- 4 channels LS injector LS drivers
- 2 channels LS drivers for O2H load with current sense
- 2 channels LS camshaft or solenoid drivers
- 5 channels LS relay drivers
- 2 channels LS LED drivers
- 3 channels LS/HS drivers with low battery function for smart start
- 1 channel LS main relay driver (MRD) with internal diode for reverse battery protection
- 5 channels pre-drivers for external FET drivers - Predriver 1&3 configurable for O2H load with external Rshunt-on the source of Ext. N-Channel Mos
- 6 channels pre-drivers for internal or external igniter drivers
- 1 K-Line ISO9141/LIN 2.1 compliant
- Integrated charge-pump
- VRS-interface
- Watchdog
- Pin Wake-up
- Temperature sensor and monitoring
- Stop-counter with Wake-up
- Dual bandgap reference & oscillator
- Micro-second-channel MSC for differential single ended mode
- SEO function
- CAN-FD with wake up by CAN function
- Package LQFP100 exposed pad

Description

The L9788 is an integrated circuit designed for automotive engine management system.

L9788 is a device realized in ST BCD proprietary technology, able to provide the full set of power supplies and signal preprocessing peripherals needed to control a 4 cylinders internal combustion engine.

Table 1. Device summary

Order code	Package	Packing
L9788	LQFP100 14x14x1.4 mm (Exposed pad down 7.6x7.6 mm)	Tube
L9788TR		Tape & Reel

Contents

1	Block diagram and pin description	3
1.1	Block diagram	3
1.2	Pin description	4
2	Package information	8
2.1	LQFP100 (14x14x1.4 mm exp. pad down) package information	8
2.1.1	Exposed pad size option	10
3	Revision history	11

1 Block diagram and pin description

1.1 Block diagram

Figure 1. Block diagram

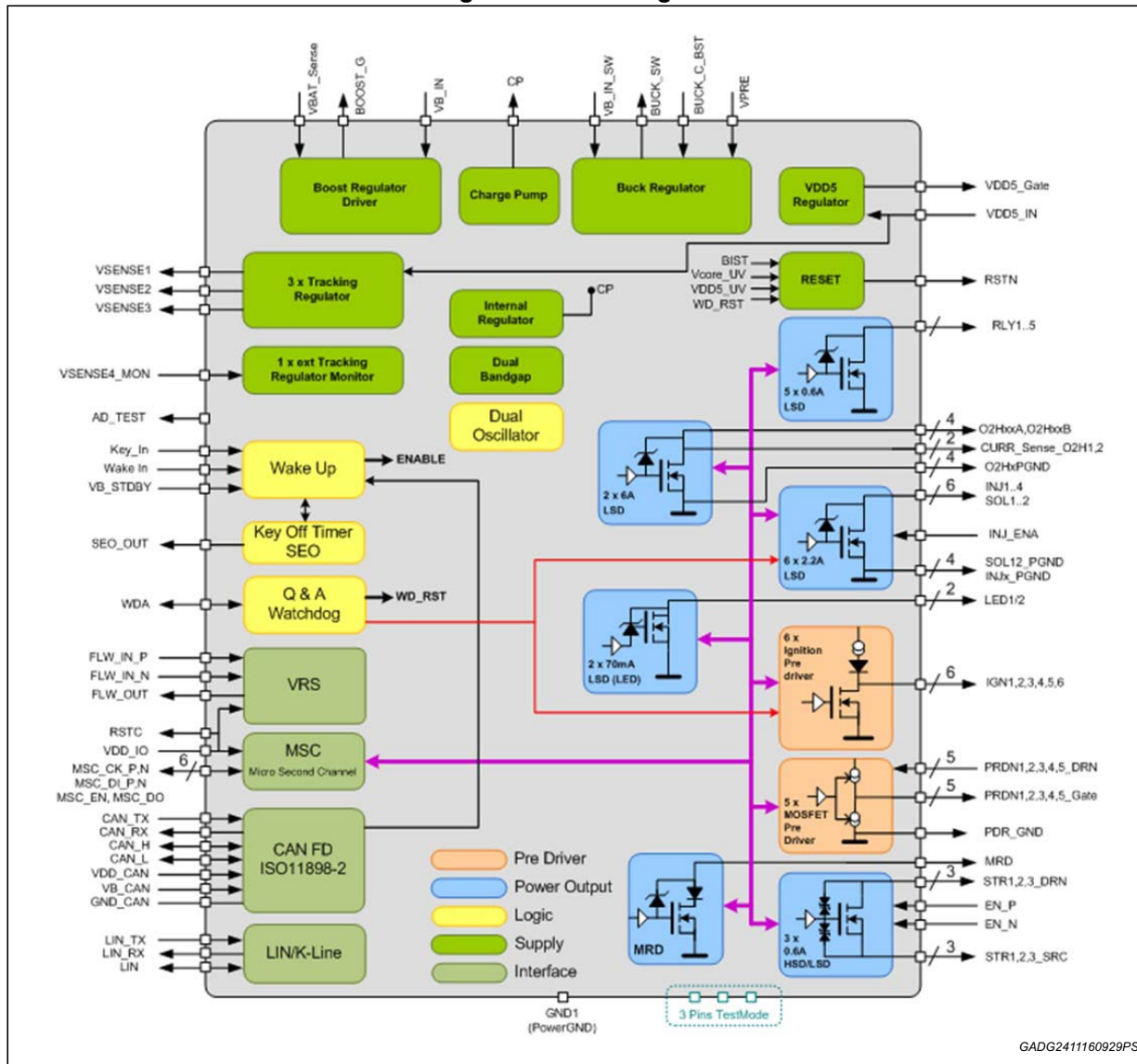

GADG2411160929PS

1.2 Pin description

Figure 2. Pin connection diagram (top view)

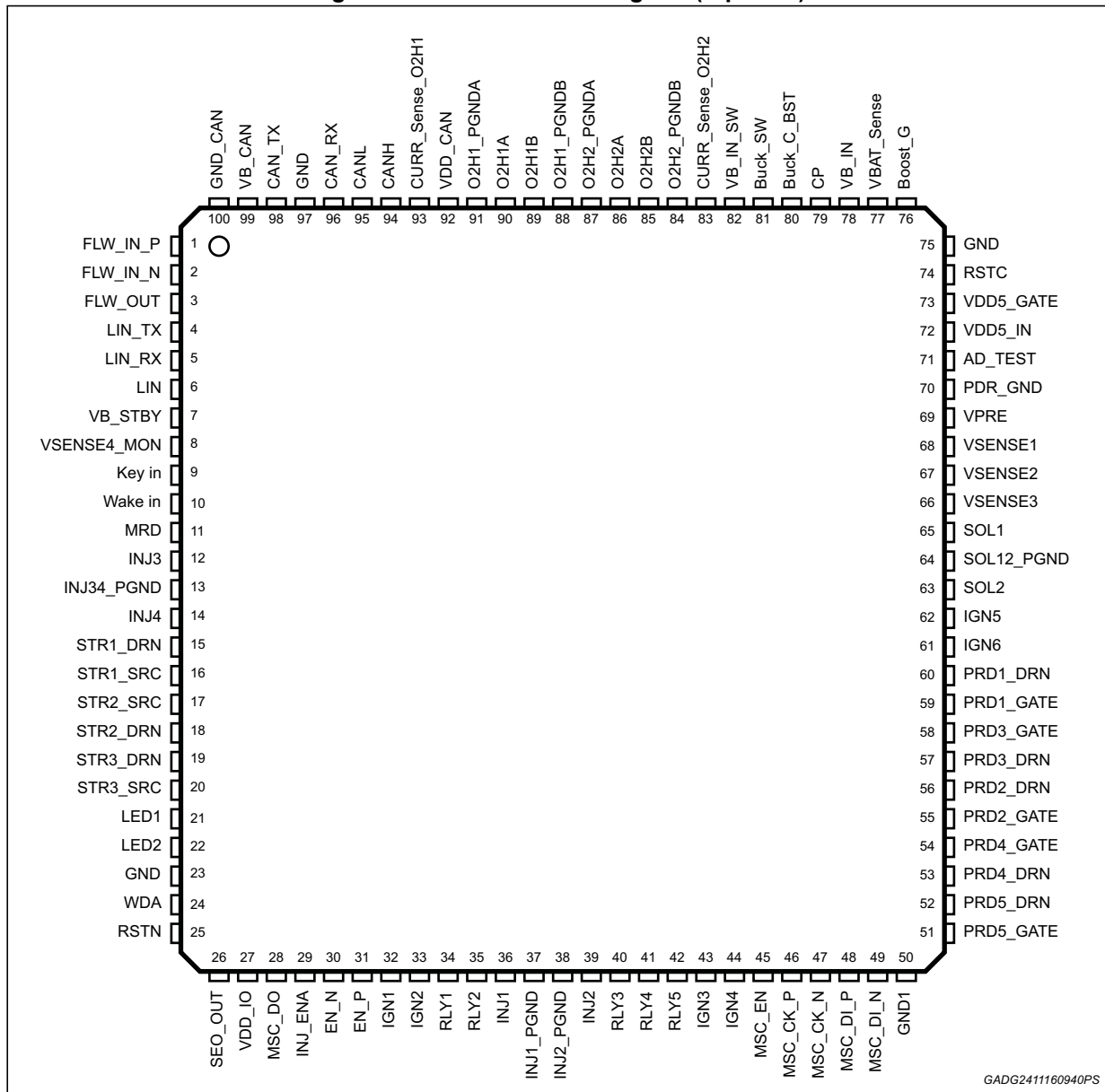

Table 2. Pin function

Pin #	Name	Function	Type	Note
1	FLW_IN_P	Flying wheel inputs voltage positive	Power In	-
2	FLW_IN_N	Flying wheel inputs voltage negative	Power In	-
3	FLW_OUT	Flying wheel output voltage	Digital Out	-
4	LIN_TX	LIN data input	Digital In	-
5	LIN_RX	LIN data output	Digital Out	-

Table 2. Pin function (continued)

Pin #	Name	Function	Type	Note
6	LIN	LIN driver output	Power In/Out	-
7	VB_STBY	Standby function supply voltage	Supply	-
8	VSENSE4_MON	tracking sensor supply Monitor	Analog In	-
9	Key in	Key signal input	Power In	-
10	Wake in	wake up signal input	Power In	-
11	MRD	Main relay drivers outpour voltage	Power Out	-
12	INJ3	Injector Driver output voltage	Power Out	-
13	INJ34_PGND	Ground	GND	-
14	INJ4	Injector Driver output voltage	Power Out	-
15	STR1_DRN	Configurable high/low side drain voltage	Power Out	-
16	STR1_SRC	Configurable high/low side source voltage	Power Out	-
17	STR2_SRC	Configurable high/low side source voltage	Power Out	-
18	STR2_DRN	Configurable high/low side drain voltage	Power Out	-
19	STR3_DRN	Configurable high/low side drain voltage	Power Out	-
20	STR3_SRC	Configurable high/low side source voltage	Power Out	-
21	LED1	LED Driver output voltage	Power Out	-
22	LED2	LED Driver output voltage	Power Out	-
23	GND	Ground	GND	-
24	WDA	Watchdog output	Digital In/Out	-
25	RSTN	Reset output for VDD5	Digital Out	-
26	SEO_OUT	SEO output pin	Digital Out	-
27	VDD_IO	Dedicated supply for FLW_OUT, MSC_DO, LIN_RX, CAN_RX	Supply	-
28	MSC_DO	MSC digital I/O voltage	Digital Out	-
29	INJ_ENA	Enable pin for injector driver	Digital In	-
30	EN_N	enable signals	Digital In	-
31	EN_P	enable signals	Digital In	-
32	IGN1	Ignition pre-driver output voltage	Power Out	-
33	IGN2	Ignition pre-driver output voltage	Power Out	-
34	RLY1	Relay Driver output voltage	Power Out	-
35	RLY2	Relay Driver output voltage	Power Out	-
36	INJ1	Injector Driver output voltage	Power Out	-
37	INJ1_PGND	Ground	GND	-
38	INJ2_PGND	Ground	GND	-
39	INJ2	Injector Driver output voltage	Power Out	-

Block diagram and pin description

L9788

Table 2. Pin function (continued)

Pin #	Name	Function	Type	Note
40	RLY3	Relay Driver output voltage	Power Out	-
41	RLY4	Relay Driver output voltage	Power Out	-
42	RLY5	Relay Driver output voltage	Power Out	-
43	IGN3	Ignition pre-driver output voltage	Power Out	-
44	IGN4	Ignition pre-driver output voltage	Power Out	-
45	MSC_EN	MSC digital I/O voltage	Digital In	-
46	MSC_CK_P	MSC digital I/O voltage	Digital In	-
47	MSC_CK_N	MSC digital I/O voltage	Digital In	-
48	MSC_DI_P	MSC digital I/O voltage	Digital In	-
49	MSC_DI_N	MSC digital I/O voltage	Digital In	-
50	GND1	Power ground	GND	Shorted to GND by package
51	PRD5_GATE	General purpose pre-drivers gate voltage	Power Out	-
52	PRD5_DRN	General purpose pre-drivers feedback voltage	Power In	-
53	PRD4_DRN	General purpose pre-drivers feedback voltage	Power In	-
54	PRD4_GATE	General purpose pre-drivers gate voltage	Power Out	-
55	PRD2_GATE	General purpose pre-drivers gate voltage	Power Out	-
56	PRD2_DRN	General purpose pre-drivers feedback voltage	Power In	-
57	PRD3_DRN	General purpose pre-drivers feedback voltage	Power In	-
58	PRD3_GATE	General purpose pre-drivers gate voltage	Power Out	-
59	PRD1_GATE	General purpose pre-drivers gate voltage	Power Out	-
60	PRD1_DRN	General purpose pre-drivers feedback voltage	Power In	-
61	IGN6	Ignition pre-driver output voltage	Power Out	-
62	IGN5	Ignition pre-driver output voltage	Power Out	-
63	SOL2	Valve driver output voltage	Power Out	-
64	SOL12_PGND	Ground	GND	-
65	SOL1	Valve driver output voltage	Power Out	-
66	VSENSE3	5V tracking sensor supply output voltage	Power Out	-
67	VSENSE2	5V tracking sensor supply output voltage	Supply Out	-
68	VSENSE1	5V tracking sensor supply output voltage	Supply Out	-
69	VPRE	Buck output voltage	Supply Out	-
70	PDR_GND	Ground pin for predriver supply feedback input	GND	-
71	AD_TEST	AD test pin	Analog Out	-
72	VDD5_IN	5V regulator feedback voltage	Power In	-
73	VDD5_GATE	5V linear regulator pre-driver output	Power Out	-

Table 2. Pin function (continued)

Pin #	Name	Function	Type	Note
74	RSTC	Reset output for VDDIO supply	Digital Out	-
75	GND	Ground	GND	-
76	Boost_G	Boost LS gate voltage	Power Out	-
77	VBAT_Sense	Battery supply voltage	Supply In	-
78	VB_IN	Battery supply voltage	Supply In	-
79	CP	Charge pump	Power Out	-
80	Buck_C_BST	Bootstrap capacitor pin	Power Out	-
81	Buck_SW	Buck switching pin	Power Out	-
82	VB_IN_SW	BUCK supply voltage	Power In	-
83	CURR_Sense_O2H2	O2heater drivers output current value	Analog Out	-
84	O2H2_PGNDDB	Ground	GND	-
85	O2H2B	O2H2B Driver output voltage	Power Out	-
86	O2H2A	O2H2A Driver output voltage	Power Out	-
87	O2H2_PGND A	Ground	GND	-
88	O2H1_PGNDDB	Ground	GND	-
89	O2H1B	O2H1B Driver output voltage	Power Out	-
90	O2H1A	O2H1A Driver output voltage	Power Out	-
91	O2H1_PGND A	Ground	GND	-
92	VDD_CAN	CAN Supply 5 V	Supply In	-
93	CURR_Sense_O2H1	O2heater drivers output current value	Analog Out	-
94	CANH	CANH output	Power In/Out	-
95	CANL	CANL output	Power In/Out	-
96	CAN_RX	CAN RX data output	Digital In/Out	-
97	GND	Ground	GND	-
98	CAN_TX	CAN TX data input	Digital In	-
99	VB_CAN	CAN enable signal	Supply In	-
100	GND_CAN	Ground CAN	GND	-

2 Package information

In order to meet environmental requirements, ST offers these devices in different grades of ECOPACK[®] packages, depending on their level of environmental compliance. ECOPACK[®] specifications, grade definitions and product status are available at: www.st.com. ECOPACK[®] is an ST trademark.

2.1 LQFP100 (14x14x1.4 mm exp. pad down) package information

Figure 3. LQFP100 (14x14x1.4 mm exp. pad down) package outline

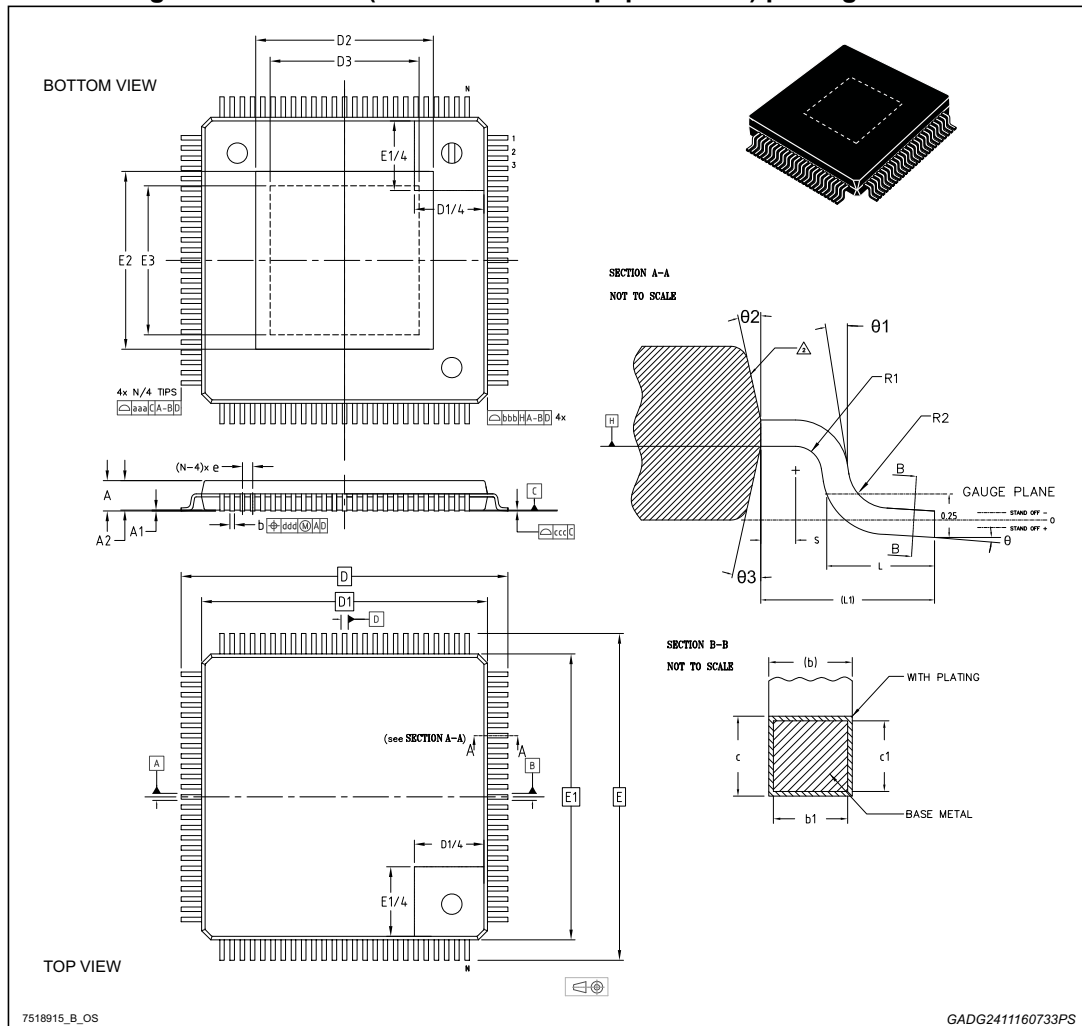

Table 3. LQFP100 (14x14x1.4 mm exp. pad down) package mechanical data

Symbol	Dimensions in mm		
	Min.	Typ.	Max.
θ	0°	3.5°	6°
$\theta 1$	0°	-	-

Table 3. LQFP100 (14x14x1.4 mm exp. pad down) package mechanical data (continued)

Symbol	Dimensions in mm		
	Min.	Typ.	Max.
Θ2	11°	12°	13°
Θ3	11°	12°	13°
A	-	1.40	1.60
A1	0.05	-	0.15
A2	1.35	1.40	1.45
b	0.17	0.22	0.27
b1	0.17	0.20	0.23
c	0.09	-	0.20
c1	0.09	-	0.16
D	16.00 BSC		
D1 ⁽¹⁾⁽²⁾	16.00 BSC		
D2	See VARIATIONS		
D3	See VARIATIONS		
e	0.50 BSC		
E	16.00 BSC		
E1 ⁽¹⁾⁽²⁾	14.00 BSC		
E2	See VARIATIONS		
E3	See VARIATIONS		
L	0.45	0.60	0.75
L1	1.00 REF		
N	100		
R1	0.08	-	-
R2	0.08	-	0.20
S	0.20	-	-
Tolerance of form and position			
aaa	0.20		
bbb	0.20		
ccc	0.08		
ddd	0.08		
VARIATIONS			
Pad option 3.5x3.5 (T3)⁽³⁾			
D2	-	-	4.61
E2	-	-	4.61
D3	2.30	-	-
E3	2.30	-	-

Table 3. LQFP100 (14x14x1.4 mm exp. pad down) package mechanical data (continued)

Symbol	Dimensions in mm		
	Min.	Typ.	Max.
Pad option 4.5X4.5 (T3)⁽³⁾			
D2	-	-	4.71
E2	-	-	4.71
D3	3.30	-	-
E3	3.30	-	-
Pad option 6.0X6.0 (T3)⁽³⁾			
D2	-	-	6.21
E2	-	-	6.21
D3	4.96	-	-
E3	4.96	-	-
Pad option 7.6X7.6 (T3)⁽³⁾			
D2	-	-	7.95
E2	-	-	7.95
D3	6.34	-	-
E3	6.34	-	-

1. Dimensions D1 and E1 do not include mold flash or protrusions. Allowable mold flash or protrusion is "0.25 mm" per side.
2. The Top package body size may be smaller than the bottom package size by much as 0.15 mm.
3. Number, dimensions and position of shown grooves are for reference only:

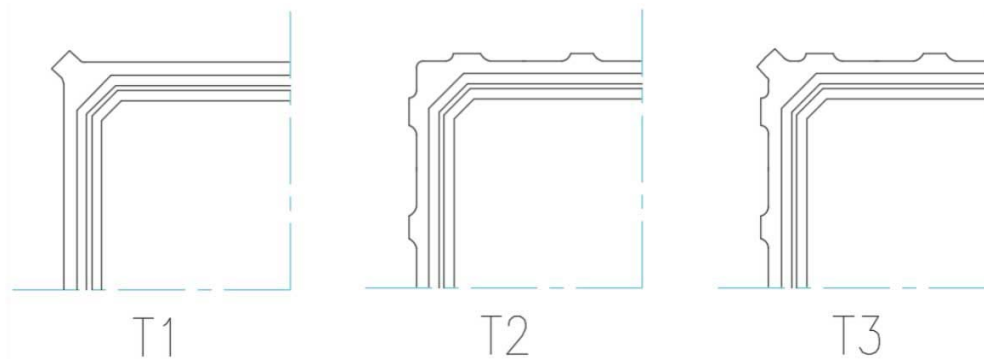

GADG2108170827PS

2.1.1 Exposed pad size option

L9788 uses the exposed pad option 7.6 x 7.6 mm.

3 Revision history

Table 4. Document revision history

Date	Revision	Changes
06-Oct-2017	1	Initial release.

IMPORTANT NOTICE – PLEASE READ CAREFULLY

STMicroelectronics NV and its subsidiaries (“ST”) reserve the right to make changes, corrections, enhancements, modifications, and improvements to ST products and/or to this document at any time without notice. Purchasers should obtain the latest relevant information on ST products before placing orders. ST products are sold pursuant to ST’s terms and conditions of sale in place at the time of order acknowledgement.

Purchasers are solely responsible for the choice, selection, and use of ST products and ST assumes no liability for application assistance or the design of Purchasers’ products.

No license, express or implied, to any intellectual property right is granted by ST herein.

Resale of ST products with provisions different from the information set forth herein shall void any warranty granted by ST for such product.

ST and the ST logo are trademarks of ST. All other product or service names are the property of their respective owners.

Information in this document supersedes and replaces information previously supplied in any prior versions of this document.

© 2017 STMicroelectronics – All rights reserved

OUR CERTIFICATE

DiGi provide top-quality products and perfect service for customer worldwide through standardization, technological innovation and continuous improvement. DiGi through third-party certification, we stricly control the quality of products and services. Welcome your RFQ to

Email: Info@DiGi-Electronics.com



Tel: +00 852-30501935

RFQ Email: Info@DiGi-Electronics.com

DiGi is a global authorized distributor of electronic components.