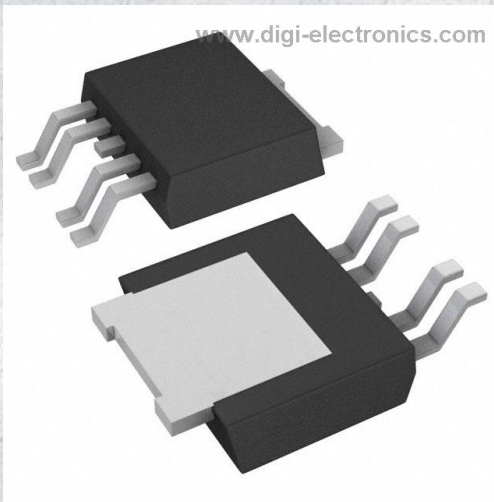


# LD29080PT15R Datasheet



<https://www.DiGi-Electronics.com>

DiGi Electronics Part Number	LD29080PT15R-DG
Manufacturer	<a href="#">STMicroelectronics</a>
Manufacturer Product Number	LD29080PT15R
Description	IC REG LINEAR 1.5V 800MA PPAK
Detailed Description	Linear Voltage Regulator IC Positive Fixed 1 Output 800mA PPAK

This model LD29080PT15R is available at DiGi Electronics.

DiGi Electronics offers a global database of semiconductor and electronic component datasheets.

We welcome your inquiries regarding pricing, lead time, or other product-related questions.

 [Request a Quote](#)

 [Datasheet Search](#)



Tel: +00 852-30501935

RFQ Email: [Info@DiGi-Electronics.com](mailto:Info@DiGi-Electronics.com)

DiGi is a global authorized distributor of electronic components.

## Purchase and inquiry

Manufacturer Product Number:

LD29080PT15R

Series:

-

Output Configuration:

Positive

Number of Regulators:

1

Voltage - Output (Min/Fixed):

1.5V

Voltage Dropout (Max):

-

Current - Quiescent (Iq):

180  $\mu$ A

PSRR:

75dB (120Hz)

Protection Features:

Over Current, Over Temperature

Mounting Type:

Surface Mount

Supplier Device Package:

PPAK

Manufacturer:

STMicroelectronics

Product Status:

Obsolete

Output Type:

Fixed

Voltage - Input (Max):

13V

Voltage - Output (Max):

-

Current - Output:

800mA

Current - Supply (Max):

35 mA

Control Features:

Enable

Operating Temperature:

-40°C ~ 125°C

Package / Case:

TO-252-5, DPAK (4 Leads + Tab), TO-252AD

Base Product Number:

LD29080

## Environmental & Export classification

RoHS Status:

ROHS3 Compliant

REACH Status:

REACH Unaffected

HTSUS:

8542.39.0001

Moisture Sensitivity Level (MSL):

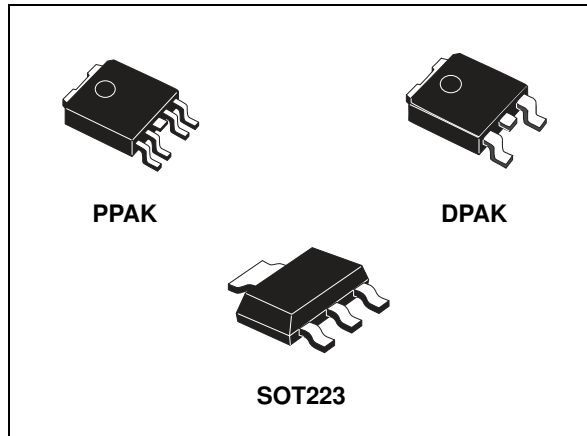
1 (Unlimited)

ECCN:

EAR99

## 800 mA fixed and adjustable output very low drop voltage regulator

Datasheet - production data



## Description

The LD29080 is a medium current, high accuracy, low-dropout voltage regulators series. These regulators feature 400 mV dropout voltage and very low ground current. Designed for medium current loads, these devices also find applications in lower current, extremely low dropout-critical systems, where their tiny dropout voltage and ground current values are important attributes. Typical application are in power supply switching post regulation, series power supply for monitors, series power supply for VCRs and TVs, computer systems and battery powered systems.

## Features

- Very low dropout voltage (typ. 0.4 at 800 mA)
- Guaranteed output current up to 800 mA
- Fixed and adjustable output voltage ( $\pm 1\%$  at 25 °C)
- Internal current and thermal limit
- Logic controlled electronic shutdown

Table 1. Device summary

Order codes			Output voltages
DPAK (tape and reel)	PPAK (tape and reel)	SOT223	
LD29080DT15R	LD29080PT15R		1.5 V
LD29080DT18R	LD29080PT18R		1.8 V
LD29080DT25R	LD29080PT25R		2.5 V
LD29080DT33R	LD29080PT33R	LD29080S33R	3.3 V
LD29080DT50R	LD29080PT50R		5.0 V
LD29080DT90R	LD29080PT90R		9.0 V
	LD29080PTR		ADJ

---

# Contents

<b>1</b>	<b>Diagram</b> .....	<b>3</b>
<b>2</b>	<b>Pin configuration</b> .....	<b>4</b>
<b>3</b>	<b>Maximum ratings</b> .....	<b>5</b>
<b>4</b>	<b>Electrical characteristics</b> .....	<b>6</b>
<b>5</b>	<b>Typical characteristics</b> .....	<b>14</b>
<b>6</b>	<b>Package mechanical data</b> .....	<b>17</b>
<b>7</b>	<b>Packaging mechanical data</b> .....	<b>23</b>
<b>8</b>	<b>Revision history</b> .....	<b>25</b>

# 1 Diagram

Figure 1. Schematic diagram for adjustable version

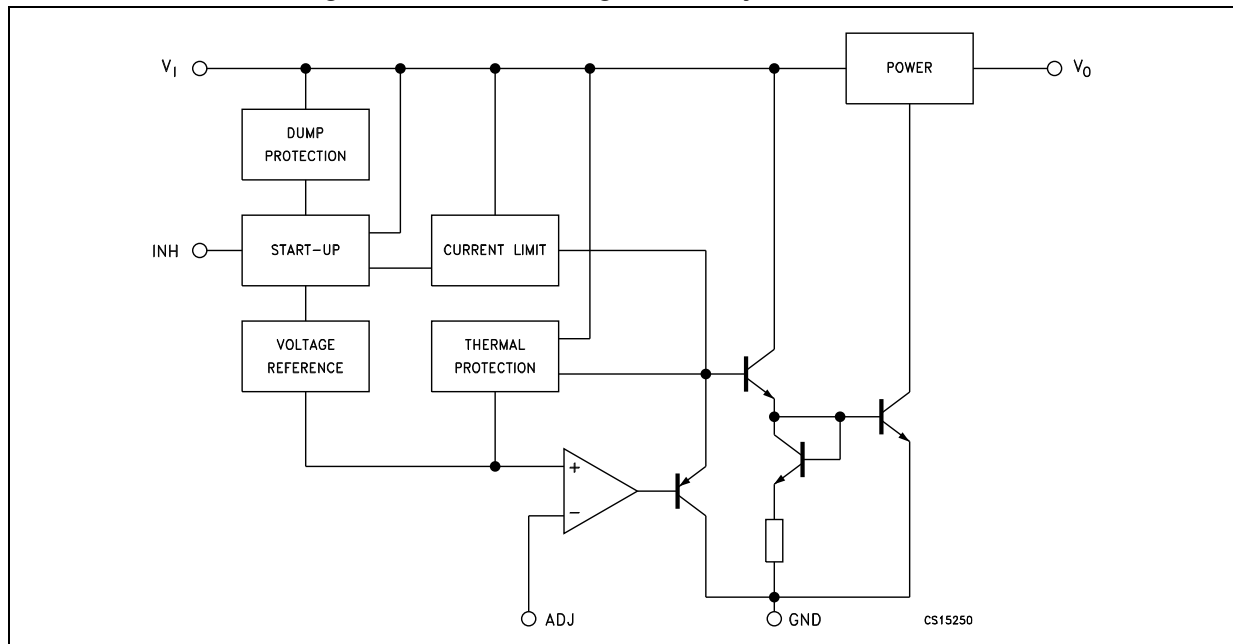
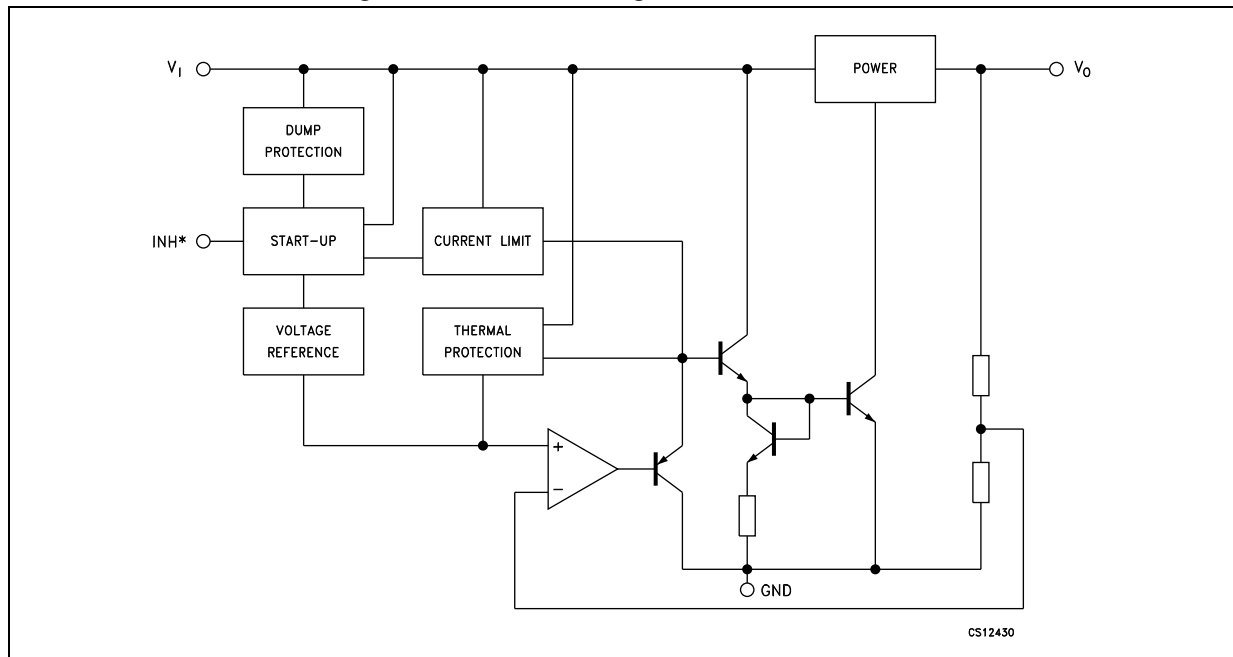


Figure 2. Schematic diagram for fixed version



\* Only for version with inhibit function.

## 2 Pin configuration

Figure 3. Pin connections (top view)

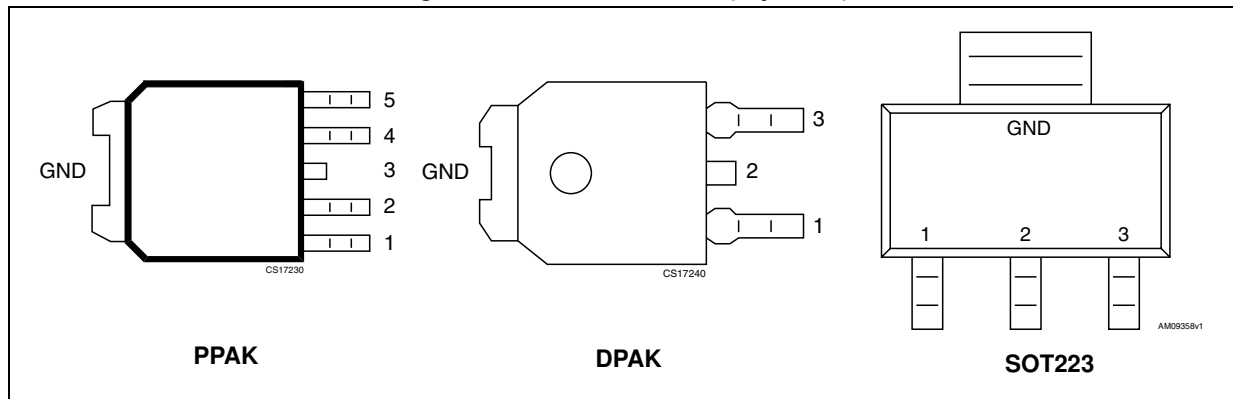
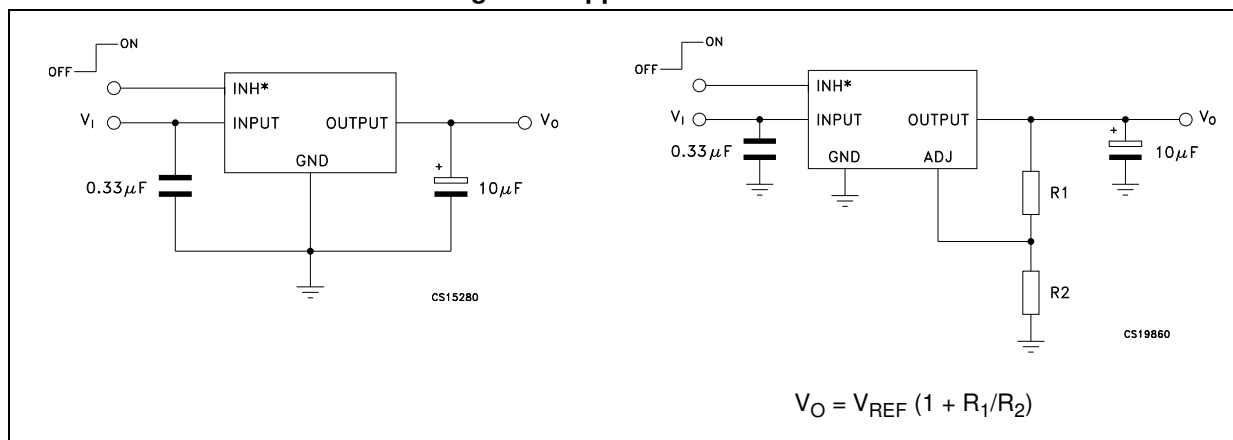


Table 2. Pin description

Symbol	PPAK	DPAK	SOT223
$V_I$	2	1	1
GND	3	2	2
$V_O$	4	3	3
ADJ/N.C. <sup>(1)</sup>	5		
INHIBIT <sup>(2)</sup>	1		

1. Not connected for fixed version.
2. Not internally pulled up; in order to assure the operating condition (device in ON mode), it must be connected to a positive voltage higher than 2 V.

Figure 4. Application circuit



\* Only for version with inhibit function.

### 3 Maximum ratings

**Table 3. Absolute maximum ratings**

Symbol	Parameter	Value	Unit
$V_I$	DC input voltage	30 <sup>(1)</sup>	V
$V_{INH}$	Inhibit input voltage	14	V
$I_O$	Output current	Internally limited	mA
$P_D$	Power dissipation	Internally limited	mW
$T_{STG}$	Storage temperature range	- 55 to 150	°C
$T_{OP}$	Operating temperature range	- 40 to 125	°C

1. Above 14 V the device is automatically in shut-down.

*Note: Absolute maximum ratings are those values beyond which damage to the device may occur. Functional operation under these conditions is not implied.*

**Table 4. Thermal data**

Symbol	Parameter	DPAK	PPAK	SOT223	Unit
$R_{thJC}$	Thermal resistance junction-case	8	8	25	°C/W
$R_{thJA}$	Thermal resistance junction-ambient	100	100	110	°C/W

## 4 Electrical characteristics

$I_O = 10$  mA, (*Note 4*)  $T_J = 25$  °C,  $V_I = 3.5$  V,  $V_{INH} = 2$  V,  $C_I = 330$  nF,  $C_O = 10$  μF, unless otherwise specified.

**Table 5. Electrical characteristics of LD29080#15**

Symbol	Parameter	Test conditions	Min.	Typ.	Max.	Unit
$V_I$	Operating input voltage	$I_O = 10$ mA to 800 mA	2.5		13	V
$V_O$	Output voltage	$I_O = 10$ mA to 800 mA, $V_I = 3$ to 7 V $T_J = -40$ to 125 °C	1.485	1.5	1.515	V
			1.463		1.537	
$\Delta V_O$	Load regulation	$I_O = 10$ mA to 800 mA		0.2	1.0	%
$\Delta V_O$	Line regulation	$V_I = 3$ to 13 V		0.06	0.5	%
SVR	Supply voltage rejection	$f = 120$ Hz, $V_I = 3.8 \pm 1$ V, $I_O = 400$ mA ( <i>Note 1</i> )	65	75		dB
$I_q$	Quiescent current	$I_O = 10$ mA, $T_J = -40$ to 125 °C		2	5	mA
		$I_O = 400$ mA, $T_J = -40$ to 125 °C		8	20	
		$I_O = 800$ mA, $T_J = -40$ to 125 °C		14	35	
		$V_I = 13$ V, $V_{INH} = \text{GND}$ , $T_J = -40$ to 125 °C		130	180	μA
$I_{sc}$	Short circuit current	$R_L = 0$		1.2		A
$V_{IL}$	Control input logic low	OFF MODE, $T_J = -40$ to 125 °C			0.8	V
$V_{IH}$	Control input logic high	ON MODE, $T_J = -40$ to 125 °C	2			V
$I_{INH}$	Control input current	$V_{INH} = 13$ V, $T_J = -40$ to 125 °C		5	10	μA
eN	Output noise voltage	$B_P = 10$ Hz to 100 kHz, $I_O = 100$ mA ( <i>Note 1</i> )		60		μV <sub>RMS</sub>

- Note:*
- 1 *Guaranteed by design.*
  - 2 *Dropout voltage is defined as the input-to-output differential when the output voltage drops to 99% of its nominal value with  $V_O + 1$  V applied to  $V_I$ .*
  - 3 *Reference voltage is measured between output and GND pins, with ADJ PIN tied to  $V_O$ .*
  - 4 *In order to avoid any output voltage rise within the whole operating temperature range, due to output leakage current, a minimum load current of 2 mA is required.*

$I_O = 10 \text{ mA}$ , (*Note 4*)  $T_J = 25 \text{ }^\circ\text{C}$ ,  $V_I = 3.5 \text{ V}$ ,  $V_{INH} = 2 \text{ V}$ ,  $C_I = 330 \text{ nF}$ ,  $C_O = 10 \text{ } \mu\text{F}$ , unless otherwise specified.

**Table 6. Electrical characteristics of LD29080#18**

Symbol	Parameter	Test conditions	Min.	Typ.	Max.	Unit
$V_I$	Operating input voltage	$I_O = 10 \text{ mA}$ to $800 \text{ mA}$	2.5		13	V
$V_O$	Output voltage	$I_O = 10 \text{ mA}$ to $800 \text{ mA}$ , $V_I = 3$ to $7.3 \text{ V}$ $T_J = -40$ to $125 \text{ }^\circ\text{C}$	1.782 1.755	1.8	1.818 1.845	V
$\Delta V_O$	Load regulation	$I_O = 10 \text{ mA}$ to $800 \text{ mA}$		0.2	1.0	%
$\Delta V_O$	Line regulation	$V_I = 3$ to $13 \text{ V}$		0.06	0.5	%
SVR	Supply voltage rejection	$f = 120 \text{ Hz}$ , $V_I = 3.8 \pm 1 \text{ V}$ , $I_O = 400 \text{ mA}$ ( <i>Note 1</i> )	62	72		dB
$V_{DROPO}$	Dropout voltage	$I_O = 150 \text{ mA}$ , $T_J = -40$ to $125 \text{ }^\circ\text{C}$ ( <i>Note 2</i> ) $I_O = 400 \text{ mA}$ , $T_J = -40$ to $125 \text{ }^\circ\text{C}$ ( <i>Note 2</i> ) $I_O = 800 \text{ mA}$ , $T_J = -40$ to $125 \text{ }^\circ\text{C}$ ( <i>Note 2</i> )		0.1 0.2 0.4		V
$I_q$	Quiescent current	$I_O = 10 \text{ mA}$ , $T_J = -40$ to $125 \text{ }^\circ\text{C}$ $I_O = 400 \text{ mA}$ , $T_J = -40$ to $125 \text{ }^\circ\text{C}$ $I_O = 800 \text{ mA}$ , $T_J = -40$ to $125 \text{ }^\circ\text{C}$ $V_I = 13 \text{ V}$ , $V_{INH} = \text{GND}$ , $T_J = -40$ to $125 \text{ }^\circ\text{C}$		2 8 14 130	5 20 35 180	mA   $\mu\text{A}$
$I_{sc}$	Short circuit current	$R_L = 0$		1.2		A
$V_{IL}$	Control input logic low	OFF MODE, $T_J = -40$ to $125 \text{ }^\circ\text{C}$			0.8	V
$V_{IH}$	Control input logic high	ON MODE, $T_J = -40$ to $125 \text{ }^\circ\text{C}$	2			V
$I_{INH}$	Control input current	$V_{INH} = 13 \text{ V}$ , $T_J = -40$ to $125 \text{ }^\circ\text{C}$		5	10	$\mu\text{A}$
eN	Output noise voltage	$B_P = 10 \text{ Hz}$ to $100 \text{ kHz}$ , $I_O = 100 \text{ mA}$ ( <i>Note 1</i> )		72		$\mu\text{V}_{RMS}$

Note: 1 Guaranteed by design.

2 Dropout voltage is defined as the input-to-output differential when the output voltage drops to 99% of its nominal value with  $V_O + 1 \text{ V}$  applied to  $V_I$ .

3 Reference voltage is measured between output and GND pins, with ADJ PIN tied to  $V_O$ .

4 In order to avoid any output voltage rise within the whole operating temperature range, due to output leakage current, a minimum load current of  $2 \text{ mA}$  is required.

## Electrical characteristics

LD29080

$I_O = 10 \text{ mA}$ , (Note 4)  $T_J = 25 \text{ }^\circ\text{C}$ ,  $V_I = 4.5 \text{ V}$ ,  $V_{INH} = 2 \text{ V}$ ,  $C_I = 330 \text{ nF}$ ,  $C_O = 10 \text{ } \mu\text{F}$ , unless otherwise specified.

Table 7. Electrical characteristics of LD29080#25

Symbol	Parameter	Test conditions	Min.	Typ.	Max.	Unit
$V_I$	Operating input voltage	$I_O = 10 \text{ mA}$ to $800 \text{ mA}$			13	V
$V_O$	Output voltage	$I_O = 10 \text{ mA}$ to $800 \text{ mA}$ , $V_I = 3.5$ to $8 \text{ V}$ $T_J = -40$ to $125 \text{ }^\circ\text{C}$	2.475 2.438	2.5	2.525 2.562	V
$\Delta V_O$	Load regulation	$I_O = 10 \text{ mA}$ to $800 \text{ mA}$		0.2	1.0	%
$\Delta V_O$	Line regulation	$V_I = 3.5$ to $13 \text{ V}$		0.06	0.5	%
SVR	Supply voltage rejection	$f = 120 \text{ Hz}$ , $V_I = 4.5 \pm 1 \text{ V}$ , $I_O = 400 \text{ mA}$ (Note 1)	55	70		dB
$V_{DROPO}$	Dropout voltage	$I_O = 150 \text{ mA}$ , $T_J = -40$ to $125 \text{ }^\circ\text{C}$ (Note 2) $I_O = 400 \text{ mA}$ , $T_J = -40$ to $125 \text{ }^\circ\text{C}$ (Note 2) $I_O = 800 \text{ mA}$ , $T_J = -40$ to $125 \text{ }^\circ\text{C}$ (Note 2)		0.1 0.2 0.4		V
$I_q$	Quiescent current	$I_O = 10 \text{ mA}$ , $T_J = -40$ to $125 \text{ }^\circ\text{C}$ $I_O = 400 \text{ mA}$ , $T_J = -40$ to $125 \text{ }^\circ\text{C}$ $I_O = 800 \text{ mA}$ , $T_J = -40$ to $125 \text{ }^\circ\text{C}$ $V_I = 13 \text{ V}$ , $V_{INH} = \text{GND}$ , $T_J = -40$ to $125 \text{ }^\circ\text{C}$		2 8 14 130	5 20 35 180	mA   $\mu\text{A}$
$I_{sc}$	Short circuit current	$R_L = 0$		1.2		A
$V_{IL}$	Control input logic low	OFF MODE, $T_J = -40$ to $125 \text{ }^\circ\text{C}$			0.8	V
$V_{IH}$	Control input logic high	ON MODE, $T_J = -40$ to $125 \text{ }^\circ\text{C}$	2			V
$I_{INH}$	Control input current	$V_{INH} = 13 \text{ V}$ , $T_J = -40$ to $125 \text{ }^\circ\text{C}$		5	10	$\mu\text{A}$
eN	Output noise voltage	$B_P = 10 \text{ Hz}$ to $100 \text{ kHz}$ , $I_O = 100 \text{ mA}$ (Note 1)		100		$\mu\text{V}_{RMS}$

Note: 1 Guaranteed by design.

2 Dropout voltage is defined as the input-to-output differential when the output voltage drops to 99% of its nominal value with  $V_O + 1 \text{ V}$  applied to  $V_I$ .

3 Reference voltage is measured between output and GND pins, with ADJ PIN tied to  $V_O$ .

4 In order to avoid any output voltage rise within the whole operating temperature range, due to output leakage current, a minimum load current of  $2 \text{ mA}$  is required.

$I_O = 10 \text{ mA}$ , (*Note 4*)  $T_J = 25 \text{ }^\circ\text{C}$ ,  $V_I = 5.3 \text{ V}$ ,  $V_{INH} = 2 \text{ V}$ ,  $C_I = 330 \text{ nF}$ ,  $C_O = 10 \text{ } \mu\text{F}$ , unless otherwise specified.

**Table 8. Electrical characteristics of LD29080#33**

Symbol	Parameter	Test conditions	Min.	Typ.	Max.	Unit
$V_I$	Operating input voltage	$I_O = 10 \text{ mA}$ to $800 \text{ mA}$			13	V
$V_O$	Output voltage	$I_O = 10 \text{ mA}$ to $800 \text{ mA}$ , $V_I = 4.3$ to $8.8 \text{ V}$ $T_J = -40$ to $125 \text{ }^\circ\text{C}$	3.267 3.218	3.3	3.333 3.382	V
$\Delta V_O$	Load regulation	$I_O = 10 \text{ mA}$ to $800 \text{ mA}$		0.2	1.0	%
$\Delta V_O$	Line regulation	$V_I = 4.3$ to $13 \text{ V}$		0.06	0.5	%
SVR	Supply voltage rejection	$f = 120 \text{ Hz}$ , $V_I = 5.3 \pm 1 \text{ V}$ , $I_O = 400 \text{ mA}$ ( <i>Note 1</i> )	52	67		dB
$V_{DROPO}$	Dropout voltage	$I_O = 150 \text{ mA}$ , $T_J = -40$ to $125 \text{ }^\circ\text{C}$ ( <i>Note 2</i> ) $I_O = 400 \text{ mA}$ , $T_J = -40$ to $125 \text{ }^\circ\text{C}$ ( <i>Note 2</i> ) $I_O = 800 \text{ mA}$ , $T_J = -40$ to $125 \text{ }^\circ\text{C}$ ( <i>Note 2</i> )		0.1 0.2 0.4		V
$I_q$	Quiescent current	$I_O = 10 \text{ mA}$ , $T_J = -40$ to $125 \text{ }^\circ\text{C}$ $I_O = 400 \text{ mA}$ , $T_J = -40$ to $125 \text{ }^\circ\text{C}$ $I_O = 800 \text{ mA}$ , $T_J = -40$ to $125 \text{ }^\circ\text{C}$ $V_I = 13 \text{ V}$ , $V_{INH} = \text{GND}$ , $T_J = -40$ to $125 \text{ }^\circ\text{C}$		2 8 14 130	5 20 35 180	mA   $\mu\text{A}$
$I_{sc}$	Short circuit current	$R_L = 0$		1.2		A
$V_{IL}$	Control input logic low	OFF MODE, $T_J = -40$ to $125 \text{ }^\circ\text{C}$			0.8	V
$V_{IH}$	Control input logic high	ON MODE, $T_J = -40$ to $125 \text{ }^\circ\text{C}$	2			V
$I_{INH}$	Control input current	$V_{INH} = 13 \text{ V}$ , $T_J = -40$ to $125 \text{ }^\circ\text{C}$		5	10	$\mu\text{A}$
eN	Output noise voltage	$B_P = 10 \text{ Hz}$ to $100 \text{ kHz}$ , $I_O = 100 \text{ mA}$ ( <i>Note 1</i> )		132		$\mu\text{V}_{RMS}$

Note: 1 Guaranteed by design.

2 Dropout voltage is defined as the input-to-output differential when the output voltage drops to 99% of its nominal value with  $V_O + 1 \text{ V}$  applied to  $V_I$ .

3 Reference voltage is measured between output and GND pins, with ADJ PIN tied to  $V_O$ .

4 In order to avoid any output voltage rise within the whole operating temperature range, due to output leakage current, a minimum load current of  $2 \text{ mA}$  is required.

## Electrical characteristics

LD29080

$I_O = 10 \text{ mA}$ , (*Note 4*)  $T_J = 25 \text{ }^\circ\text{C}$ ,  $V_I = 7 \text{ V}$ ,  $V_{\text{INH}} = 2 \text{ V}$ ,  $C_I = 330 \text{ nF}$ ,  $C_O = 10 \text{ } \mu\text{F}$ , unless otherwise specified.

Table 9. Electrical characteristics of LD29080#50

Symbol	Parameter	Test conditions	Min.	Typ.	Max.	Unit
$V_I$	Operating input voltage	$I_O = 10 \text{ mA}$ to $800 \text{ mA}$			13	V
$V_O$	Output voltage	$I_O = 10 \text{ mA}$ to $800 \text{ mA}$ , $V_I = 6$ to $10.5 \text{ V}$ $T_J = -40$ to $125 \text{ }^\circ\text{C}$	4.95	5	5.05	V
			4.875		5.125	
$\Delta V_O$	Load regulation	$I_O = 10 \text{ mA}$ to $800 \text{ mA}$		0.2	1.0	%
$\Delta V_O$	Line regulation	$V_I = 6$ to $13 \text{ V}$		0.06	0.5	%
SVR	Supply voltage rejection	$f = 120 \text{ Hz}$ , $V_I = 7 \pm 1 \text{ V}$ , $I_O = 400 \text{ mA}$ ( <i>Note 1</i> )	49	64		dB
$V_{\text{DROP}}$	Dropout voltage	$I_O = 150 \text{ mA}$ , $T_J = -40$ to $125 \text{ }^\circ\text{C}$ ( <i>Note 2</i> )		0.1		V
		$I_O = 400 \text{ mA}$ , $T_J = -40$ to $125 \text{ }^\circ\text{C}$ ( <i>Note 2</i> )		0.2		
		$I_O = 800 \text{ mA}$ , $T_J = -40$ to $125 \text{ }^\circ\text{C}$ ( <i>Note 2</i> )		0.4	0.7	
$I_q$	Quiescent current	$I_O = 10 \text{ mA}$ , $T_J = -40$ to $125 \text{ }^\circ\text{C}$		2	5	mA
		$I_O = 400 \text{ mA}$ , $T_J = -40$ to $125 \text{ }^\circ\text{C}$		8	20	
		$I_O = 800 \text{ mA}$ , $T_J = -40$ to $125 \text{ }^\circ\text{C}$		14	35	
		$V_I = 13 \text{ V}$ , $V_{\text{INH}} = \text{GND}$ , $T_J = -40$ to $125 \text{ }^\circ\text{C}$		130	180	$\mu\text{A}$
$I_{\text{sc}}$	Short circuit current	$R_L = 0$		1.2		A
$V_{\text{IL}}$	Control input logic low	OFF MODE, $T_J = -40$ to $125 \text{ }^\circ\text{C}$			0.8	V
$V_{\text{IH}}$	Control input logic high	ON MODE, $T_J = -40$ to $125 \text{ }^\circ\text{C}$	2			V
$I_{\text{INH}}$	Control input current	$V_{\text{INH}} = 13 \text{ V}$ , $T_J = -40$ to $125 \text{ }^\circ\text{C}$		5	10	$\mu\text{A}$
eN	Output noise voltage	$B_P = 10 \text{ Hz}$ to $100 \text{ kHz}$ , $I_O = 100 \text{ mA}$ ( <i>Note 1</i> )		180		$\mu\text{V}_{\text{RMS}}$

Note: 1 Guaranteed by design.

2 Dropout voltage is defined as the input-to-output differential when the output voltage drops to 99% of its nominal value with  $V_O + 1 \text{ V}$  applied to  $V_I$ .

3 Reference voltage is measured between output and GND pins, with ADJ PIN tied to  $V_O$ .

4 In order to avoid any output voltage rise within the whole operating temperature range, due to output leakage current, a minimum load current of  $2 \text{ mA}$  is required.

$I_O = 10$  mA, (Note 4)  $T_J = 25$  °C,  $V_I = 10$  V,  $V_{INH} = 2$  V,  $C_I = 330$  nF,  $C_O = 10$   $\mu$ F, unless otherwise specified)

Table 10. Electrical characteristics of LD29080#80

Symbol	Parameter	Test conditions	Min.	Typ.	Max.	Unit
$V_I$	Operating input voltage	$I_O = 10$ mA to 800 mA			13	V
$V_O$	Output voltage	$I_O = 10$ mA to 800 mA, $V_I = 9$ to 13 V $T_J = -40$ to 125 °C	7.92 7.80	8	8.08 8.20	V
$\Delta V_O$	Load regulation	$I_O = 10$ mA to 800 mA		0.2	1.0	%
$\Delta V_O$	Line regulation	$V_I = 9$ to 13 V		0.06	0.5	%
SVR	Supply voltage rejection	$f = 120$ Hz, $V_I = 10 \pm 1$ V, $I_O = 400$ mA (Note 1)	45	59		dB
$V_{DROPO}$	Dropout voltage	$I_O = 150$ mA, $T_J = -40$ to 125 °C (Note 2) $I_O = 400$ mA, $T_J = -40$ to 125 °C (Note 2) $I_O = 800$ mA, $T_J = -40$ to 125 °C (Note 2)		0.1 0.2 0.4		V
$I_q$	Quiescent current	$I_O = 10$ mA, $T_J = -40$ to 125 °C $I_O = 400$ mA, $T_J = -40$ to 125 °C $I_O = 800$ mA, $T_J = -40$ to 125 °C $V_I = 13$ V, $V_{INH} = \text{GND}$ , $T_J = -40$ to 125 °C		2 8 14 130	5 20 35 180	mA   $\mu$ A
$I_{sc}$	Short circuit current	$R_L = 0$		1.2		A
$V_{IL}$	Control input logic low	OFF MODE, $T_J = -40$ to 125 °C			0.8	V
$V_{IH}$	Control input logic high	ON MODE, $T_J = -40$ to 125 °C	2			V
$I_{INH}$	Control input current	$V_{INH} = 13$ V, $T_J = -40$ to 125 °C		5	10	$\mu$ A
eN	Output noise voltage	$B_P = 10$ Hz to 100 kHz, $I_O = 100$ mA (Note 1)		320		$\mu$ V <sub>RMS</sub>

Note: 1 Guaranteed by design.

2 Dropout voltage is defined as the input-to-output differential when the output voltage drops to 99% of its nominal value with  $V_O + 1$  V applied to  $V_I$ .

3 Reference voltage is measured between output and GND pins, with ADJ PIN tied to  $V_O$ .

4 In order to avoid any output voltage rise within the whole operating temperature range, due to output leakage current, a minimum load current of 2 mA is required.

## Electrical characteristics

LD29080

$I_O = 10$  mA, (Note 4)  $T_J = 25$  °C,  $V_I = 11$  V,  $V_{INH} = 2$  V,  $C_I = 330$  nF,  $C_O = 10$   $\mu$ F, unless otherwise specified.

Table 11. Electrical characteristics of LD29080#90

Symbol	Parameter	Test conditions	Min.	Typ.	Max.	Unit
$V_I$	Operating input voltage	$I_O = 10$ mA to 800 mA			13	V
$V_O$	Output voltage	$I_O = 10$ mA to 800 mA, $V_I = 9$ to 13 V $T_J = -40$ to 125 °C	8.91	9	9.09	V
			8.775		9.225	
$\Delta V_O$	Load regulation	$I_O = 10$ mA to 800 mA		0.2	1.0	%
$\Delta V_O$	Line regulation	$V_I = 10$ to 13 V		0.06	0.5	%
SVR	Supply voltage rejection	$f = 120$ Hz, $V_I = 11 \pm 1$ V, $I_O = 400$ mA (Note 1)	43	57		dB
$V_{DROPO}$	Dropout voltage	$I_O = 150$ mA, $T_J = -40$ to 125 °C (Note 2)		0.1		V
		$I_O = 400$ mA, $T_J = -40$ to 125 °C (Note 2)		0.2		
		$I_O = 800$ mA, $T_J = -40$ to 125 °C (Note 2)		0.4	0.7	
$I_q$	Quiescent current	$I_O = 10$ mA, $T_J = -40$ to 125 °C		2	5	mA
		$I_O = 400$ mA, $T_J = -40$ to 125 °C		8	20	
		$I_O = 800$ mA, $T_J = -40$ to 125 °C		14	35	
		$V_I = 13$ V, $V_{INH} = \text{GND}$ , $T_J = -40$ to 125 °C		130	180	$\mu$ A
$I_{sc}$	Short circuit current	$R_L = 0$		1.2		A
$V_{IL}$	Control input logic low	OFF MODE, $T_J = -40$ to 125 °C			0.8	V
$V_{IH}$	Control input logic high	ON MODE, $T_J = -40$ to 125 °C	2			V
$I_{INH}$	Control input current	$V_{INH} = 13$ V, $T_J = -40$ to 125 °C		5	10	$\mu$ A
eN	Output noise voltage	$B_P = 10$ Hz to 100 kHz, $I_O = 100$ mA (Note 1)		330		$\mu$ V <sub>RMS</sub>

Note: 1 Guaranteed by design.

2 Dropout voltage is defined as the input-to-output differential when the output voltage drops to 99% of its nominal value with  $V_O + 1$  V applied to  $V_I$ .

3 Reference voltage is measured between output and GND pins, with ADJ PIN tied to  $V_O$ .

4 In order to avoid any output voltage rise within the whole operating temperature range, due to output leakage current, a minimum load current of 2 mA is required.

$I_O = 10$  mA, (Note 4)  $T_J = 25$  °C,  $V_I = 10$  V,  $V_{INH} = 2$  V,  $C_I = 330$  nF,  $C_O = 10$   $\mu$ F, unless otherwise specified.

Table 12. Electrical characteristics of LD29080#ADJ

Symbol	Parameter	Test conditions	Min.	Typ.	Max.	Unit
$V_I$	Operating input voltage	$I_O = 10$ mA to 800 mA	2.5		13	V
$\Delta V_O$	Load regulation	$I_O = 10$ mA to 800 mA		0.2	1.0	%
$\Delta V_O$	Line regulation	$V_I = 2.5$ to 13 V, $I_O = 10$ mA		0.06	0.5	%
$V_{REF}$	Reference voltage	$I_O = 10$ mA to 800 mA, $V_I = 2.5$ to 6.73 V $T_J = -40$ to 125 °C (Note 3)	1.2177	1.23	1.2423	V
			1.1993		1.2607	
SVR	Supply voltage rejection	$f = 120$ Hz, $V_I = 3.23 \pm 1$ V, $I_O = 400$ mA (Note 1)	45	75		dB
$I_q$	Quiescent current	$I_O = 10$ mA, $T_J = -40$ to 125 °C		2	5	mA
		$I_O = 400$ mA, $T_J = -40$ to 125 °C		8	20	
		$I_O = 800$ mA, $T_J = -40$ to 125 °C		14	35	
		$V_I = 13$ V, $V_{INH} = GND$ , $T_J = -40$ to 125 °C		130	180	$\mu$ A
$I_{ADJ}$	Adjust pin current	$T_J = -40$ to 125 °C			1	$\mu$ A
$I_{sc}$	Short circuit current	$R_L = 0$		1.2		A
$V_{IL}$	Control input logic low	OFF MODE, $T_J = -40$ to 125 °C			0.8	V
$V_{IH}$	Control input logic high	ON MODE, $T_J = -40$ to 125 °C	2			V
$I_{INH}$	Control input current	$V_{INH} = 13$ V, $T_J = -40$ to 125 °C		5	10	$\mu$ A
eN	Output noise voltage	$B_P = 10$ Hz to 100 kHz, $I_O = 100$ mA (Note 1)		50		$\mu$ V <sub>RMS</sub>

Note: 1 Guaranteed by design.

2 Dropout voltage is defined as the input-to-output differential when the output voltage drops to 99% of its nominal value with  $V_O + 1$  V applied to  $V_I$ .

3 Reference voltage is measured between output and GND pins, with ADJ PIN tied to  $V_O$ .

4 In order to avoid any output voltage rise within the whole operating temperature range, due to output leakage current, a minimum load current of 2 mA is required.

## 5 Typical characteristics

Figure 5. Output voltage vs. temperature

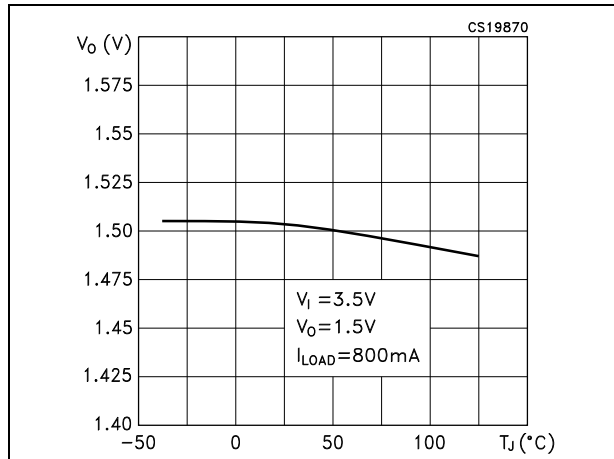


Figure 6. Reference voltage vs. temperature

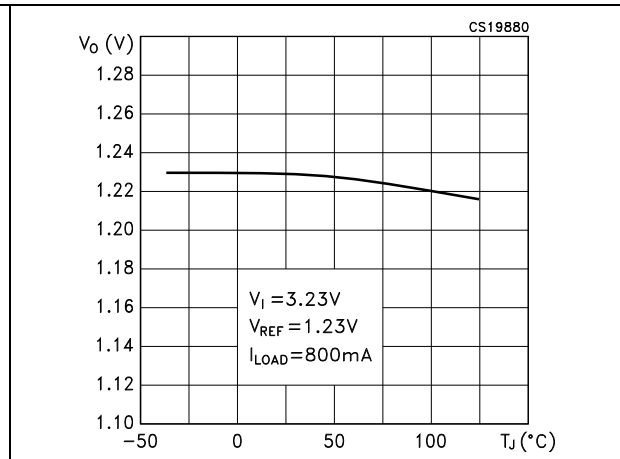


Figure 7. Dropout voltage vs. temperature

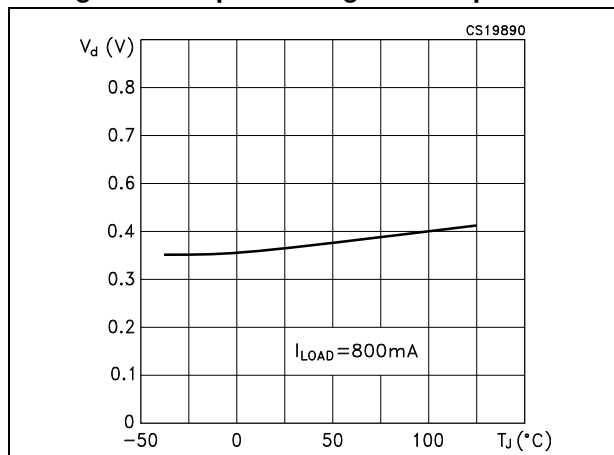


Figure 8. Dropout voltage vs. output current

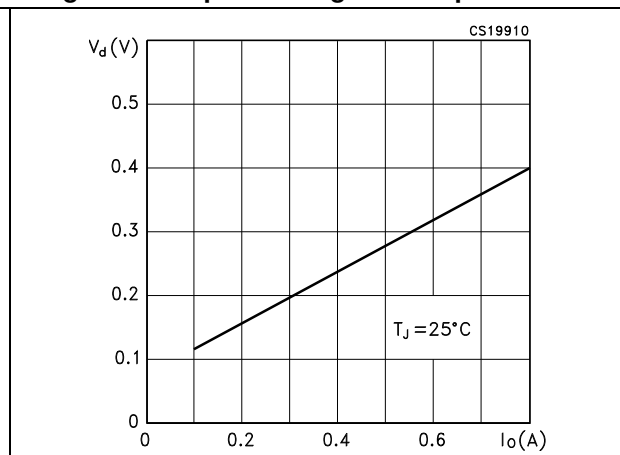


Figure 9. Quiescent current vs. output current

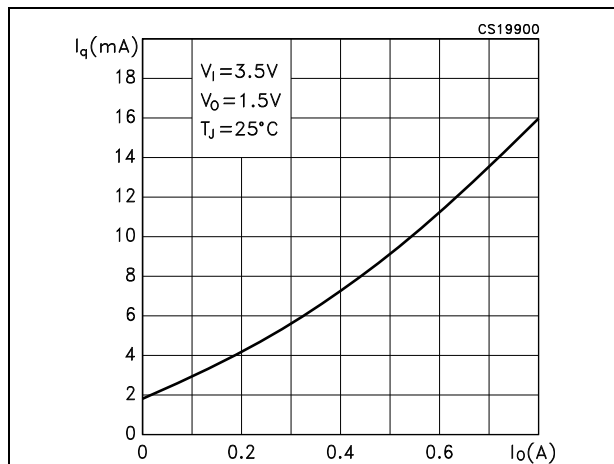
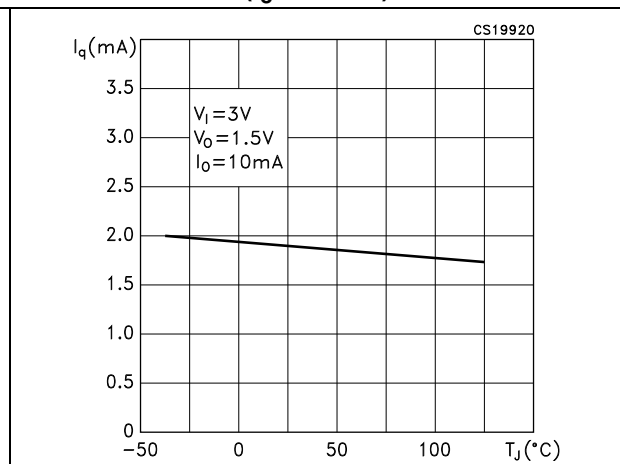
Figure 10. Quiescent current vs. temperature ( $I_O = 10\text{ mA}$ )

Figure 11. Quiescent current vs. supply voltage

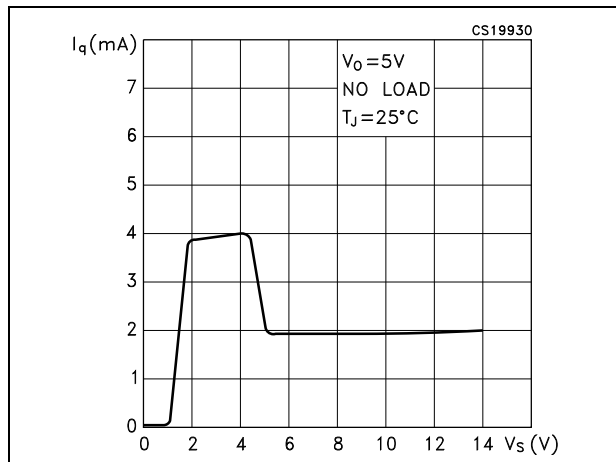


Figure 12. Quiescent current vs. temperature (Io = 800 mA)

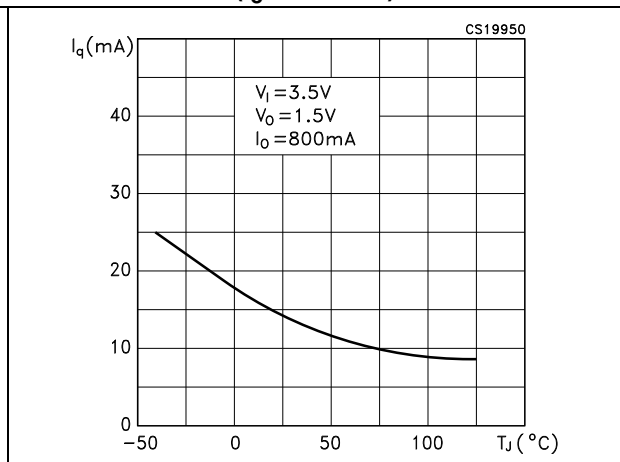


Figure 13. Short circuit current vs. temperature

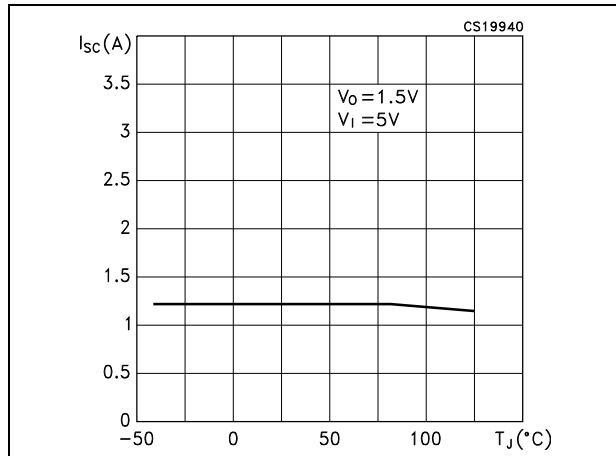


Figure 14. Adjust pin current vs. temperature

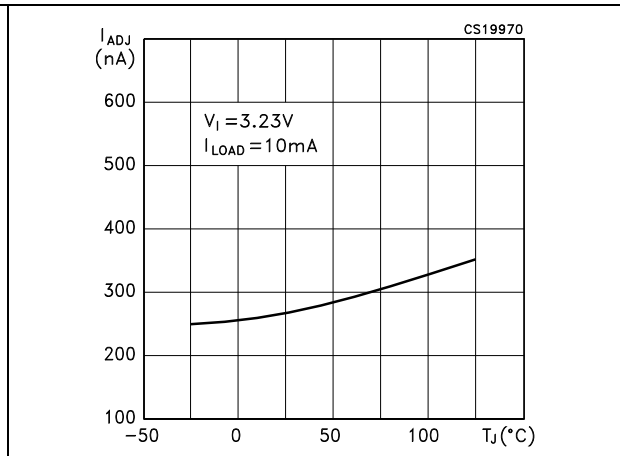


Figure 15. Supply voltage rejection vs. temperature

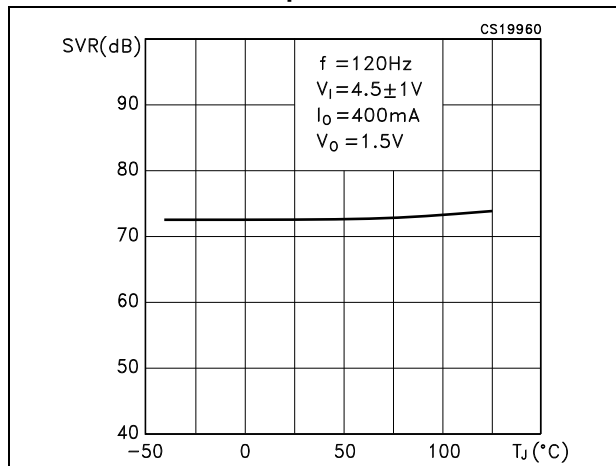


Figure 16. Output voltage vs. input voltage

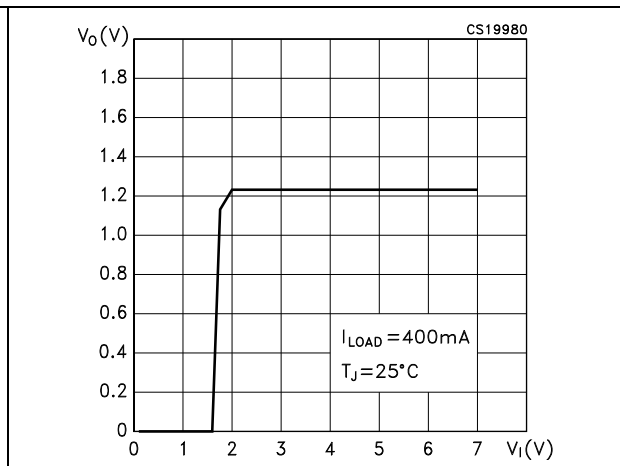


Figure 17. Stability vs.  $C_O$

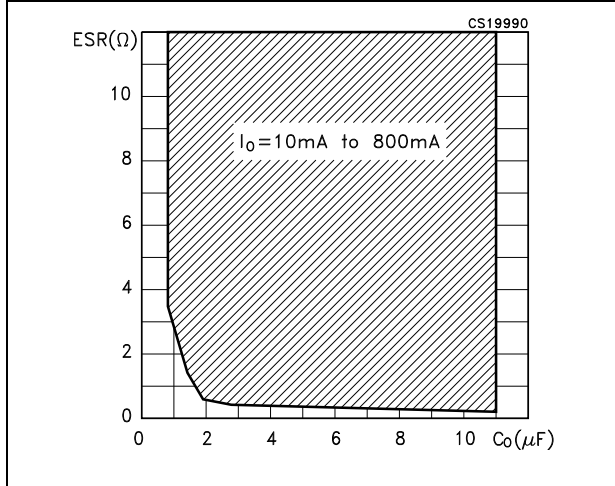


Figure 18. Line transient

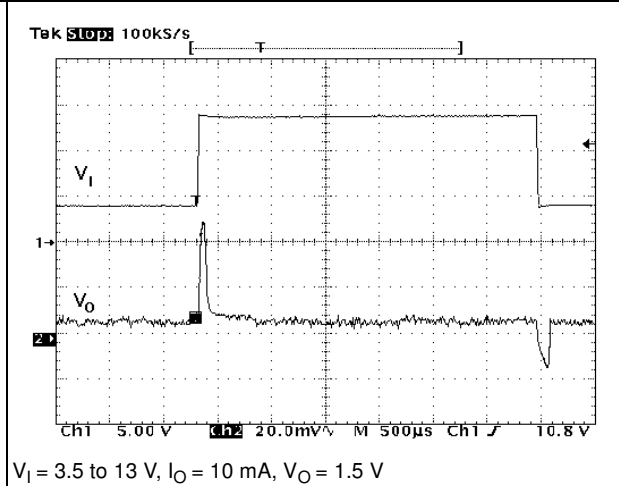
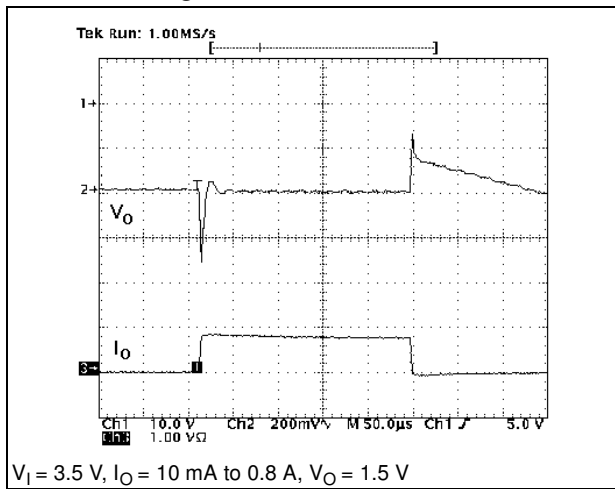


Figure 19. Load transient



## 6 Package mechanical data

In order to meet environmental requirements, ST offers these devices in different grades of ECOPACK packages, depending on their level of environmental compliance. ECOPACK specifications, grade definitions and product status are available at: [www.st.com](http://www.st.com). ECOPACK is an ST trademark.

**Table 13. PPAK mechanical data**

Dim.	mm		
	Min.	Typ.	Max.
A	2.2		2.4
A1	0.9		1.1
A2	0.03		0.23
B	0.4		0.6
B2	5.2		5.4
C	0.45		0.6
C2	0.48		0.6
D	6		6.2
D1		5.1	
E	6.4		6.6
E1		4.7	
e		1.27	
G	4.9		5.25
G1	2.38		2.7
H	9.35		10.1
L2		0.8	1
L4	0.6		1
L5	1		
L6		2.8	
R		0.20	
V2	0°		8°

Figure 20. PPAK drawing

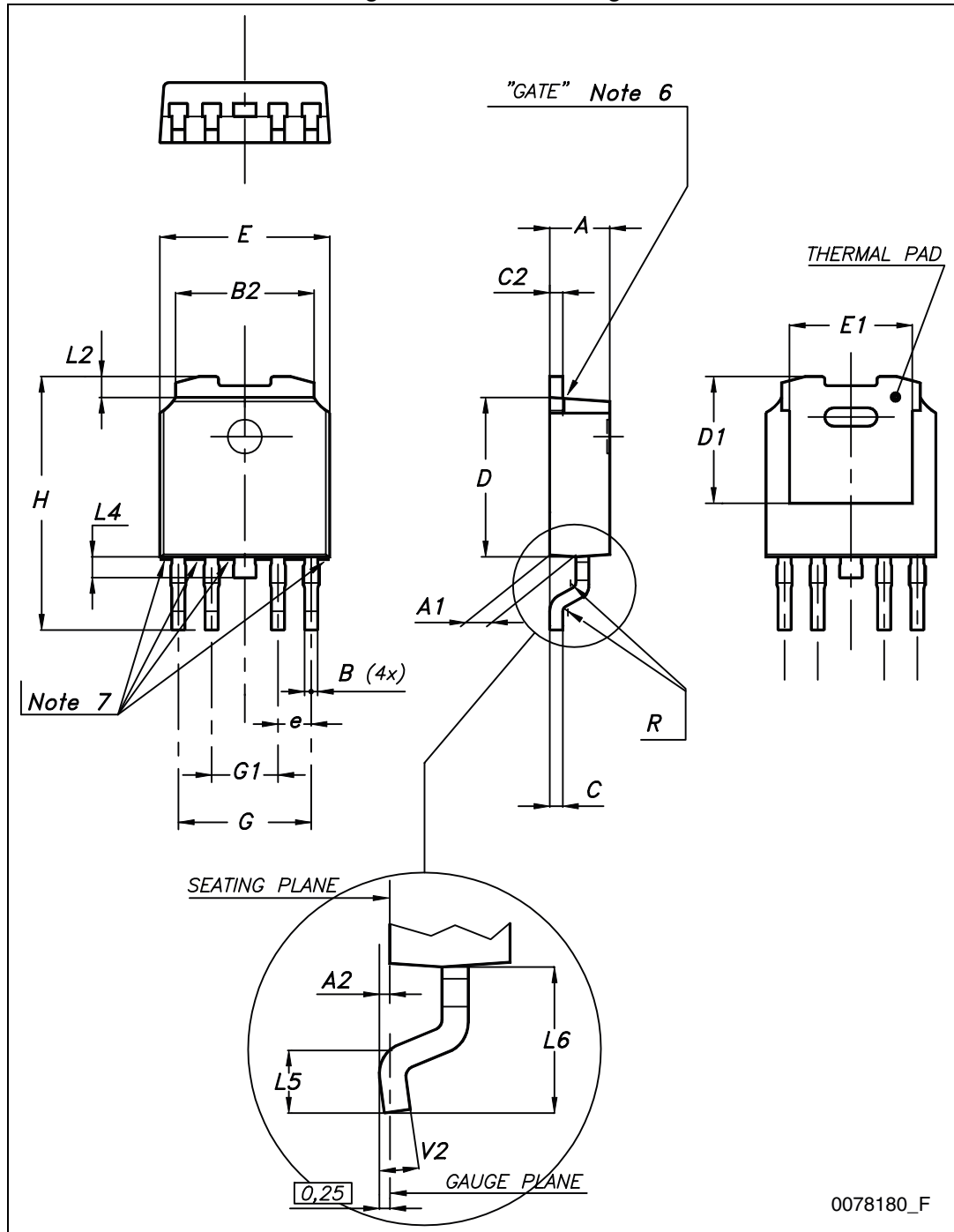


Table 14. DPAK mechanical data

Dim.	mm		
	Min.	Typ.	Max.
A	2.20		2.40
A1	0.90		1.10
A2	0.03		0.23
b	0.64		0.90
b4	5.20		5.40
c	0.45		0.60
c2	0.48		0.60
D	6.00		6.20
D1		5.10	
E	6.40		6.60
E1		4.70	
e		2.28	
e1	4.40		4.60
H	9.35		10.10
L	1.00		1.50
(L1)		2.80	
L2		0.80	
L4	0.60		1.00
R		0.20	
V2	0°		8°

Figure 21. DPAK drawing

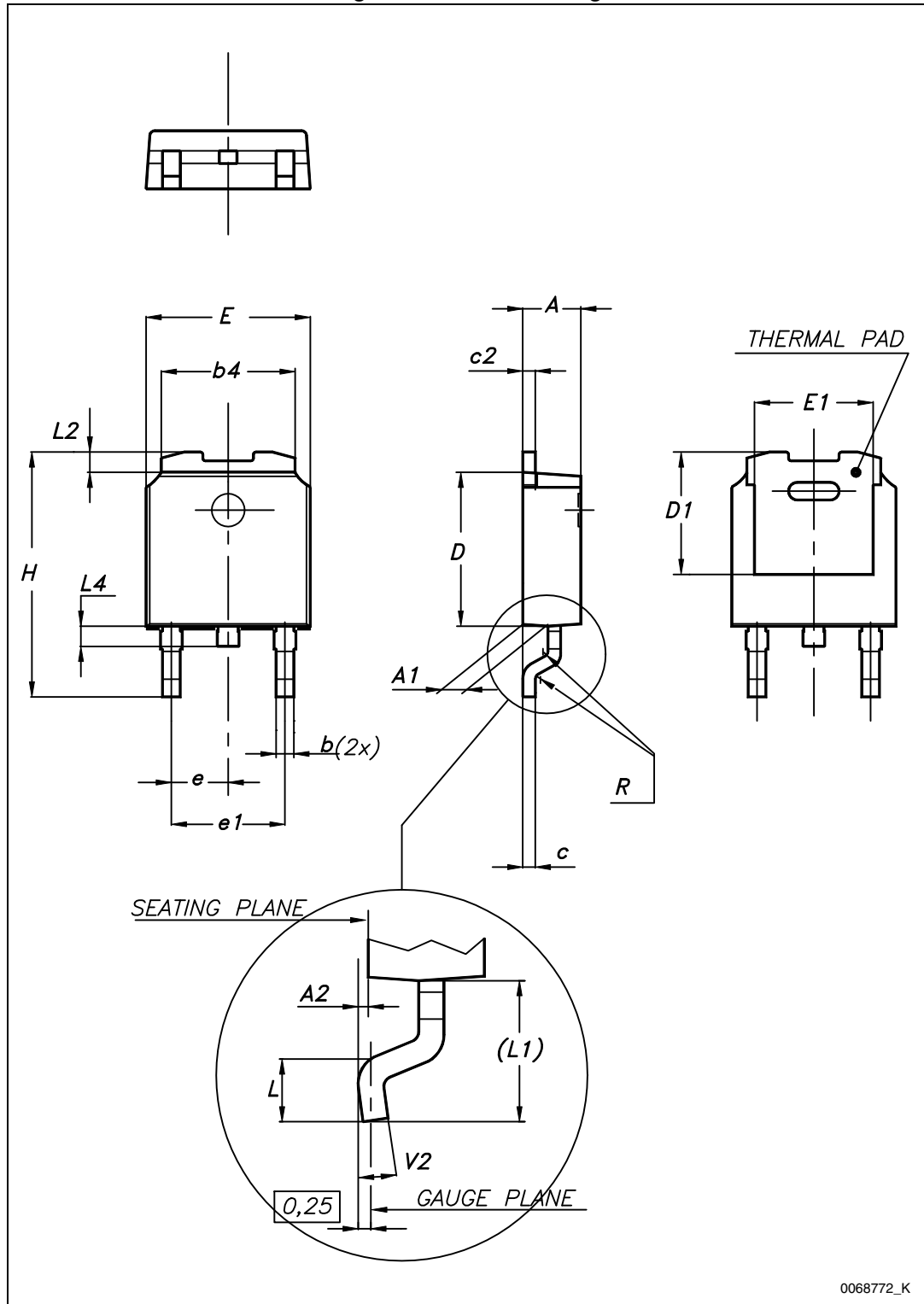
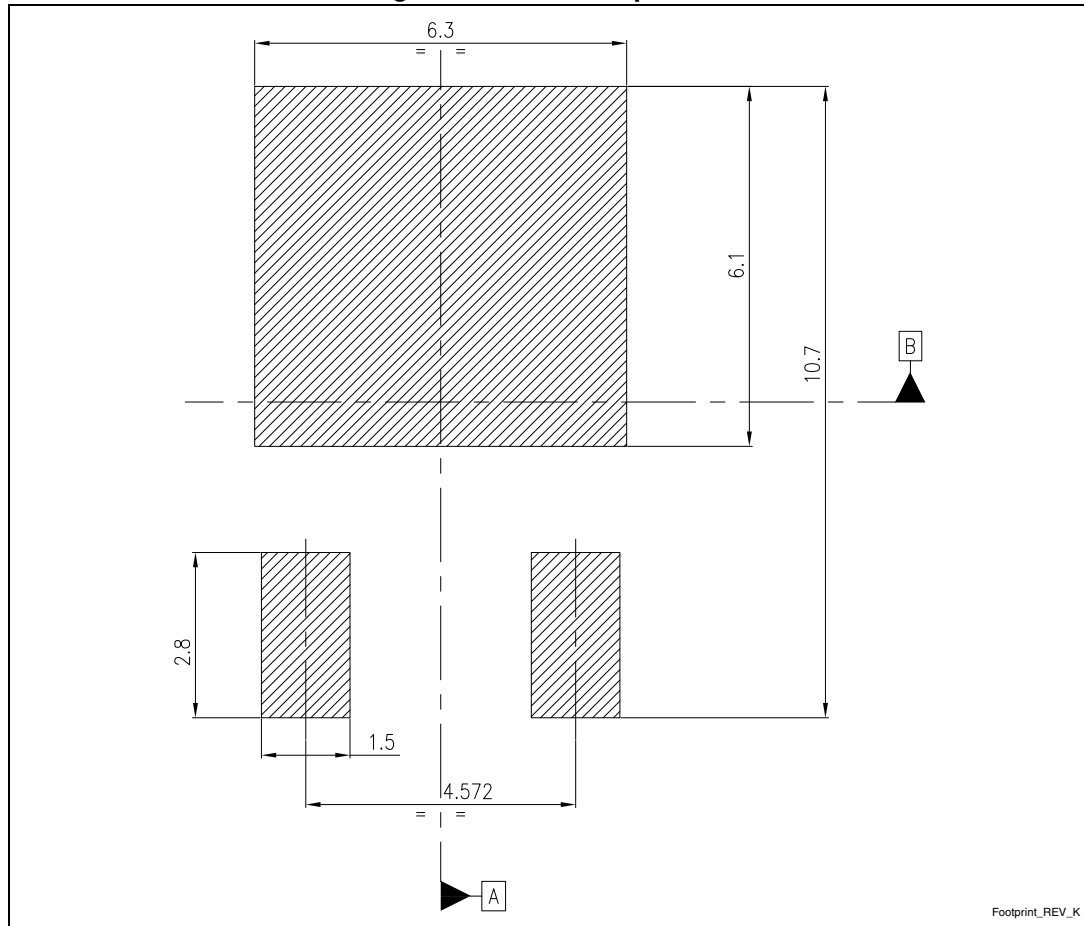


Figure 22. DPAK footprint (a)

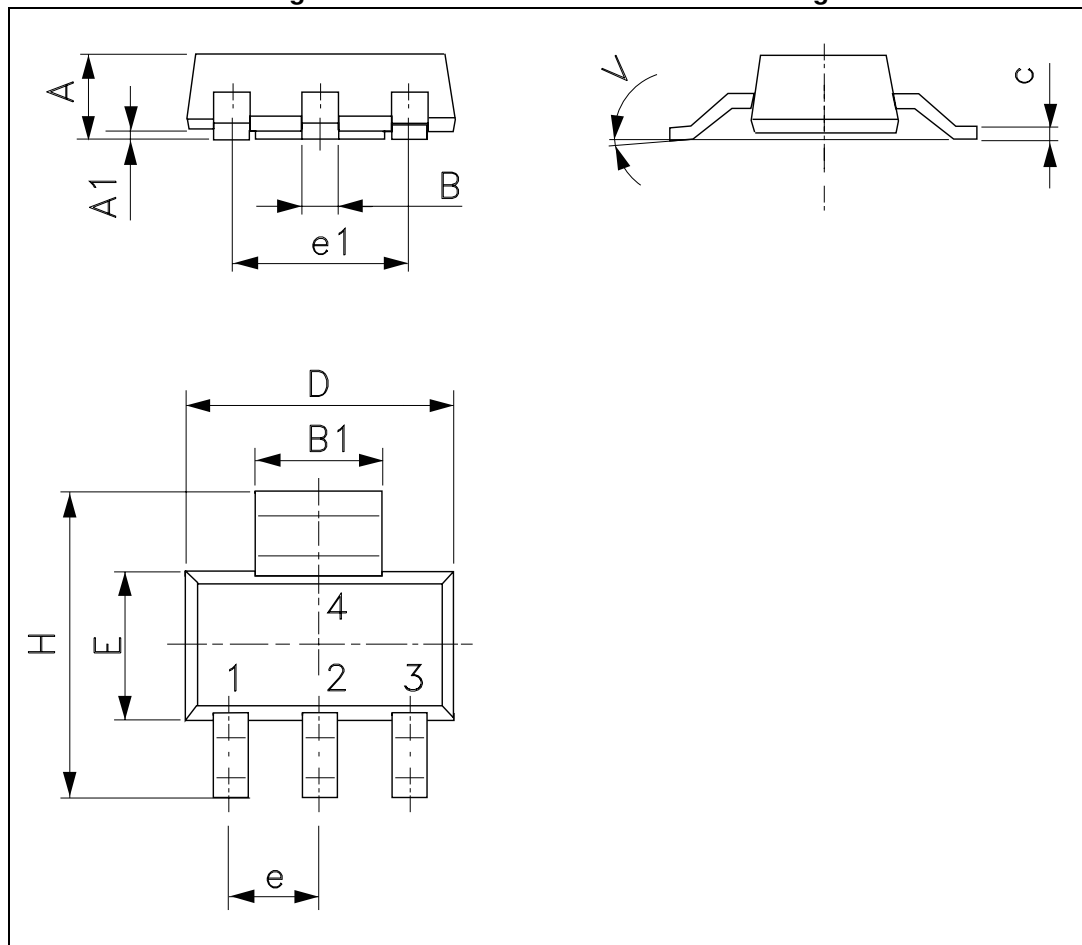


a. All dimensions are in millimeters

Table 15. SOT-223 mechanical data

Dim.	mm		
	Min.	Typ.	Max.
A			1.80
A1	0.02		0.1
B	0.60	0.70	0.85
B1	2.90	3.00	3.15
c	0.24	0.26	0.35
D	6.30	6.50	6.70
e		2.30	
e1		4.60	
E	3.30	3.50	3.70
H	6.70	7.00	7.30
V			10°

Figure 23. SOT-223 mechanical data drawing



## 7 Packaging mechanical data

Table 16. PPAK and DPAK tape and reel mechanical data

Tape			Reel		
Dim.	mm		Dim.	mm	
	Min.	Max.		Min.	Max.
A0	6.8	7	A		330
B0	10.4	10.6	B	1.5	
B1		12.1	C	12.8	13.2
D	1.5	1.6	D	20.2	
D1	1.5		G	16.4	18.4
E	1.65	1.85	N	50	
F	7.4	7.6	T		22.4
K0	2.55	2.75			
P0	3.9	4.1	Base qty.		2500
P1	7.9	8.1	Bulk qty.		2500
P2	1.9	2.1			
R	40				
T	0.25	0.35			
W	15.7	16.3			

Figure 24. Tape for PPAK and DPAK

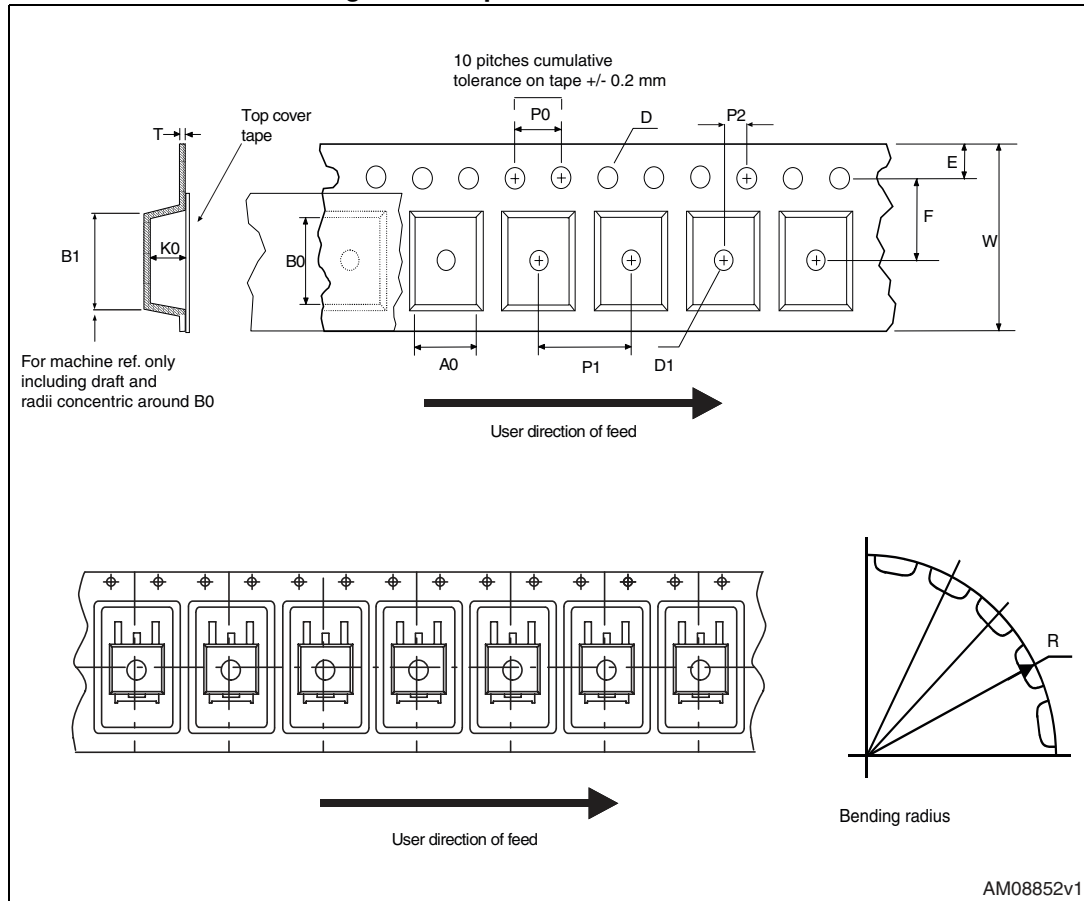
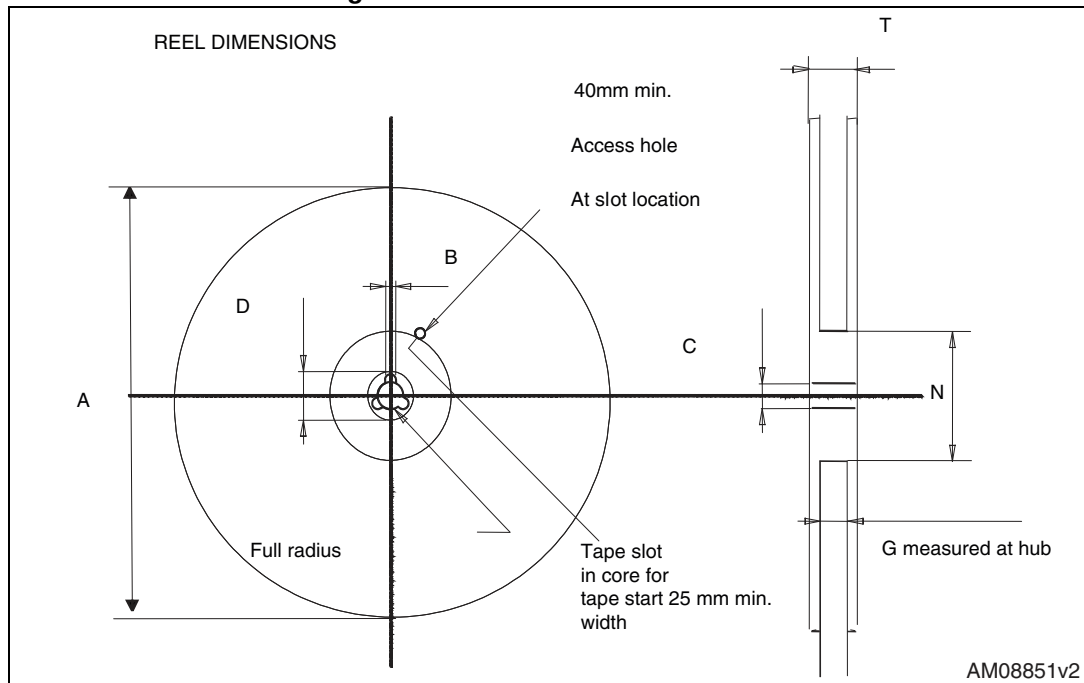


Figure 25. Reel for PPAK and DPAK



## 8 Revision history

**Table 17. Document revision history**

Date	Revision	Changes
15-Oct-2004	1	First release.
20-Oct-2005	2	Order codes updated.
14-May-2007	3	Order codes updated.
26-Jan-2009	4	Modified: eN value in Table 9 on page 10.
22-Feb-2011	5	Added: new order code Table 1 on page 1 and mechanical data.
12-Jan-2012	6	Modified: $R_{thJA}$ and $R_{thJC}$ value for SOT223 Table 4 on page 5.
08-May-2012	7	Modified: pin connections for PPAK, DPAK and SOT223 Figure 3 on page 4.
22-Nov-2013	8	Part number LD29080xx changed to LD29080. Updated the Description in cover page, Table 1: Device summary. Updated Section 5: Typical characteristics and Section 6: Package mechanical data. Added Section 7: Packaging mechanical data. Minor text changes.
13-Feb-2020	9	Updated <a href="#">Figure 23: SOT-223 mechanical data drawing</a> .

**IMPORTANT NOTICE – PLEASE READ CAREFULLY**

STMicroelectronics NV and its subsidiaries (“ST”) reserve the right to make changes, corrections, enhancements, modifications, and improvements to ST products and/or to this document at any time without notice. Purchasers should obtain the latest relevant information on ST products before placing orders. ST products are sold pursuant to ST’s terms and conditions of sale in place at the time of order acknowledgement.

Purchasers are solely responsible for the choice, selection, and use of ST products and ST assumes no liability for application assistance or the design of Purchasers’ products.

No license, express or implied, to any intellectual property right is granted by ST herein.

Resale of ST products with provisions different from the information set forth herein shall void any warranty granted by ST for such product.

ST and the ST logo are trademarks of ST. For additional information about ST trademarks, please refer to [www.st.com/trademarks](http://www.st.com/trademarks). All other product or service names are the property of their respective owners.

Information in this document supersedes and replaces information previously supplied in any prior versions of this document.

© 2020 STMicroelectronics – All rights reserved

## OUR CERTIFICATE

DiGi provide top-quality products and perfect service for customer worldwide through standardization, technological innovation and continuous improvement. DiGi through third-party certification, we stricly control the quality of products and services. Welcome your RFQ to

Email: [Info@DiGi-Electronics.com](mailto:Info@DiGi-Electronics.com)



Tel: +00 852-30501935

RFQ Email: [Info@DiGi-Electronics.com](mailto:Info@DiGi-Electronics.com)

DiGi is a global authorized distributor of electronic components.