

M24256-BRMN6TP Datasheet

www.digi-electronics.com

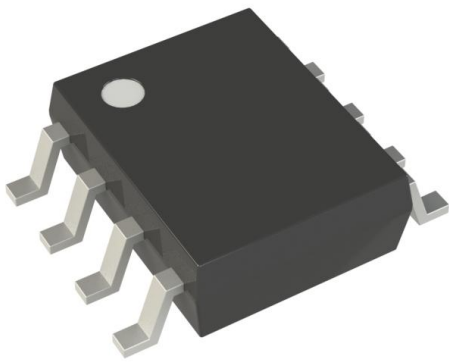

<https://www.DiGi-Electronics.com>

DiGi Electronics Part Number	M24256-BRMN6TP-DG
Manufacturer	STMicroelectronics
Manufacturer Product Number	M24256-BRMN6TP
Description	IC EEPROM 256KBIT I2C 1MHZ 8SOIC
Detailed Description	EEPROM Memory IC 256Kbit I2C 1 MHz 450 ns 8-SOIC

This model M24256-BRMN6TP is available at DiGi.Electronics.

DiGi Electronics offers a global database of semiconductor and electronic component datasheets.

We welcome your inquiries regarding pricing, lead time, or other product-related questions.

 [Request a Quote](#)

 [Datasheet Search](#)



Tel: +00 852-30501935

RFQ Email: Info@DiGi-Electronics.com

DiGi is a global authorized distributor of electronic components.

Purchase and inquiry

Manufacturer Product Number:

M24256-BRMN6TP

Series:

-

DiGi-Electronics Programmable:

Verified

Memory Format:

EEPROM

Memory Size:

256Kbit

Memory Interface:

I2C

Write Cycle Time - Word, Page:

5ms

Voltage - Supply:

1.8V ~ 5.5V

Mounting Type:

Surface Mount

Supplier Device Package:

8-SOIC

Manufacturer:

STMicroelectronics

Product Status:

Active

Memory Type:

Non-Volatile

Technology:

EEPROM

Memory Organization:

32K x 8

Clock Frequency:

1 MHz

Access Time:

450 ns

Operating Temperature:

-40°C ~ 85°C (TA)

Package / Case:

8-SOIC (0.154", 3.90mm Width)

Base Product Number:

M24256

Environmental & Export classification

RoHS Status:

ROHS3 Compliant

REACH Status:

REACH Unaffected

HTSUS:

8542.32.0051

Moisture Sensitivity Level (MSL):

1 (Unlimited)

ECCN:

EAR99

256-Kbit serial I²C bus EEPROM

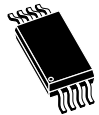

TSSOP8 (DW)
169 mil width



SO8N (MN)
150 mil width

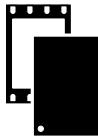

UFD8FN8 (MC)
DFN8 - 2x3 mm



WLSCP (CU)



WLSCP (CS)

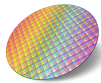

Unsaan wafer

Product status link

[M24256-BF](#)

[M24256-DF](#)

[M24256-BR](#)

[M24256-DR](#)

[M24256-BW](#)

Features

- Compatible with following I²C bus modes:
 - 1 MHz
 - 400 kHz
 - 100 kHz
- Memory array:
 - 256 Kbit (32 Kbyte) of EEPROM
 - Page size: 64 byte
 - Additional write lockable page (M24256-D order codes)
- Single supply voltage and high speed:
 - 1 MHz clock from 1.7 V to 5.5 V
- Write:
 - Byte write within 5 ms
 - Page write within 5 ms
- Operating temperature range:
 - from -40 °C up to +85 °C
- Random and sequential read modes
- Write protect of the whole memory array
- Enhanced ESD/latch-Up protection
- More than 4 million write cycles
- More than 200-years data retention

Packages

- RoHS-compliant and Halogen-free (ECOPACK2)
- SO8 ECOPACK2
- TSSOP8 ECOPACK2
- UFD8FN8 ECOPACK2
- WLSCP ECOPACK2
- Unsaan wafer (each die is tested)



1 Description

The M24256 is a 256-Kbit I²C-compatible EEPROM (electrically erasable programmable memory) organized as 32 K × 8 bits.

The M24256-BW can operate with a supply voltage from 2.5 V to 5.5 V, the M24256-BR AND M24256-DR can operate with a supply voltage from 1.8 V to 5.5 V, and the M24256-BF and M24256-DF can operate with a supply voltage from 1.7 V to 5.5 V. All these devices operate with a clock frequency of 1 MHz (or less), over an ambient temperature range of -40 °C / +85 °C. The M24256-D offers an additional page, named the identification page (64 byte). The identification page can be used to store sensitive application parameters which can be (later) permanently locked in read-only mode.

Figure 1. Logic diagram

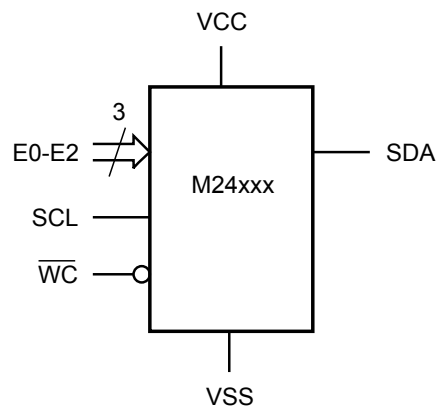
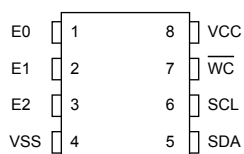

Table 1. Signal names

Signal name	Function	Direction
E2, E1, E0	Chip enable	Input
SDA	Serial data	I/O
SCL	Serial clock	Input
\overline{WC}	Write control	Input
V _{CC}	Supply voltage	-
V _{SS}	Ground	-

Figure 2. 8-pin package connections, top view



1. See Section 9 Package information for package dimensions, and how to identify pin 1



Figure 3. WLCSP connections

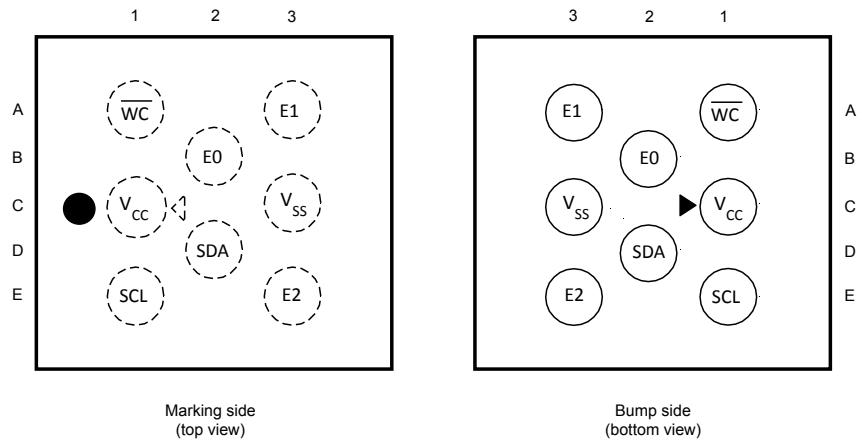

Table 2. Signal vs. bump position

Position	A	B	C	D	E
1	\overline{WC}	-	V_{CC}	-	SCL
2	-	E0	-	SDA	-
3	E1	-	V_{SS}	-	E2



2 Signal description

2.1 Serial clock (SCL)

The signal applied on the SCL input is used to strobe the data available on SDA(in) and to output the data on SDA(out).

2.2 Serial data (SDA)

SDA is an input/output used to transfer data in or data out of the device. SDA(out) is an open drain output that may be wire-OR'ed with other open drain or open collector signals on the bus. A pull-up resistor must be connected from serial data (SDA) to V_{CC} (Figure 12 indicates how to calculate the value of the pull-up resistor).

2.3 Chip enable (E2, E1, E0)

(E2,E1,E0) input signals are used to set the value that is to be looked for on the three least significant bits (b3, b2, b1) of the 7-bit device select code (see Table 3). These inputs must be tied to V_{CC} or V_{SS} , as shown in Figure 4. When not connected (left floating), these inputs are read as low (0).

Figure 4. Chip enable inputs connection

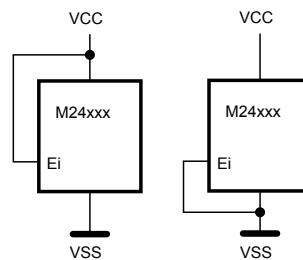

2.4 Write control (\overline{WC})

This input signal is useful for protecting the entire contents of the memory from inadvertent write operations. Write operations are disabled to the entire memory array when write control (\overline{WC}) is driven high. Write operations are enabled when write control (\overline{WC}) is either driven low or left floating.

When write control (\overline{WC}) is driven high, device select and address bytes are acknowledged, data bytes are not acknowledged.

2.5 V_{SS} (ground)

V_{SS} is the reference for the V_{CC} supply voltage.



2.6 Supply voltage (V_{CC})

2.6.1 Operating supply voltage (V_{CC})

Prior to selecting the memory and issuing instructions to it, a valid and stable V_{CC} voltage within the specified [V_{CC}(min), V_{CC}(max)] range must be applied (see Operating conditions in [Section 8 DC and AC parameters](#)). In order to secure a stable DC supply voltage, it is recommended to decouple the V_{CC} line with a suitable capacitor (usually of the order of 10 nF to 100 nF) close to the V_{CC}/V_{SS} package pins.

This voltage must remain stable and valid until the end of the transmission of the instruction and, for a write instruction, until the completion of the internal write cycle (t_w).

2.6.2 Power-up conditions

The V_{CC} voltage has to rise continuously from 0 V up to the minimum V_{CC} operating voltage (see Operating conditions in [Section 8 DC and AC parameters](#)).

2.6.3 Device reset

In order to prevent inadvertent write operations during power-up, a power-on-reset (POR) circuit is included. At power-up, the device does not respond to any instruction until V_{CC} has reached the internal reset threshold voltage. This threshold is lower than the minimum V_{CC} operating voltage (see Operating conditions in [Section 8 DC and AC parameters](#)). When V_{CC} passes over the POR threshold, the device is reset and enters the standby power mode; however, the device must not be accessed until V_{CC} reaches a valid and stable DC voltage within the specified [V_{CC}(min), V_{CC}(max)] range (see Operating conditions in [Section 8 DC and AC parameters](#)).

In a similar way, during power-down (continuous decrease in V_{CC}), the device must not be accessed when V_{CC} drops below V_{CC}(min). When V_{CC} drops below the power-on-reset threshold voltage, the device stops responding to any instruction sent to it.

2.6.4 Power-down conditions

During power-down (continuous decrease in V_{CC}), the device must be in the standby power mode (mode reached after decoding a stop condition, assuming that there is no internal write cycle in progress).



3 Memory organization

The memory is organized as shown below.

Figure 5. Block diagram

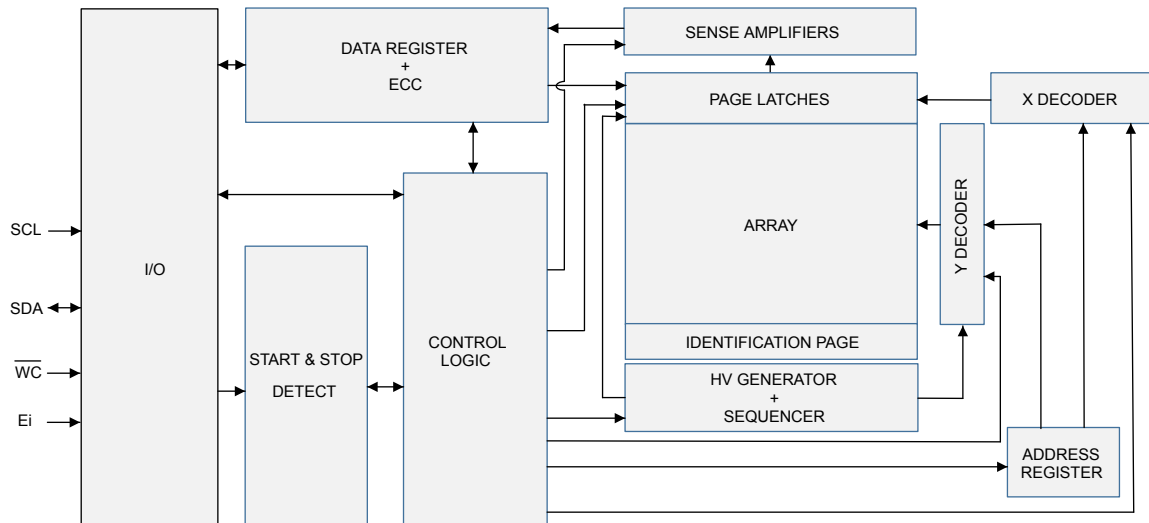



4 Device operation

The device supports the I²C protocol. This is summarized in Figure 6. Any device that sends data on to the bus is defined to be a transmitter, and any device that reads the data to be a receiver. The device that controls the data transfer is known as the bus master, and the other as the slave device. A data transfer can only be initiated by the bus master, which will also provide the serial clock for synchronization. The device is always a slave in all communications.

Figure 6. I²C bus protocol

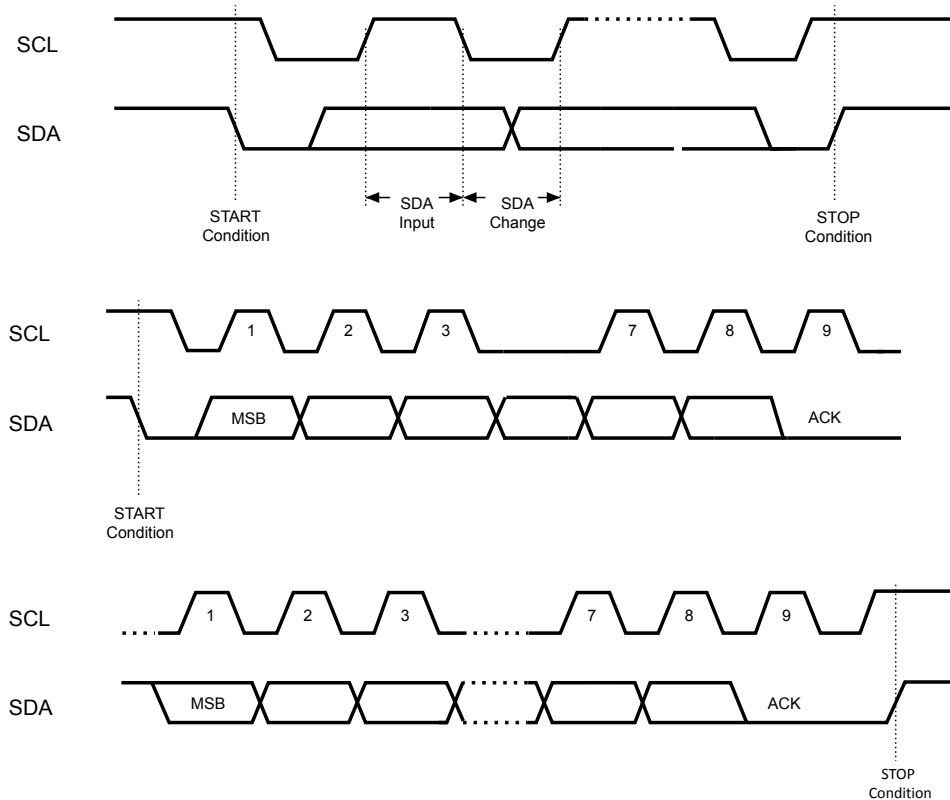



4.1 Start condition

Start is identified by a falling edge of serial data (SDA) while serial clock (SCL) is stable in the high state. A start condition must precede any data transfer instruction. The device continuously monitors (except during a write cycle) serial data (SDA) and serial clock (SCL) for a start condition.

4.2 Stop condition

Stop is identified by a rising edge of serial data (SDA) while serial clock (SCL) is stable and driven high. A stop condition terminates communication between the device and the bus master. A read instruction that is followed by NoAck can be followed by a stop condition to force the device into the standby mode.

A stop condition at the end of a write instruction triggers the internal write cycle.

4.3 Data input

During data input, the device samples serial data (SDA) on the rising edge of serial clock (SCL). For correct device operation, serial data (SDA) must be stable during the rising edge of serial clock (SCL), and the serial data (SDA) signal must change only when serial clock (SCL) is driven low.

4.4 Acknowledge bit (ACK)

The acknowledge bit is used to indicate a successful byte transfer. The bus transmitter, whether it be bus master or slave device, releases serial data (SDA) after sending eight bits of data. During the 9th clock pulse period, the receiver pulls serial data (SDA) low to acknowledge the receipt of the eight data bits.



4.5 Device addressing

To start communication between the bus master and the slave device, the bus master must initiate a Start condition. Following this, the bus master sends the device select code, shown in Table 3 (most significant bit first).

Table 3. Device select code

	Device type identifier ⁽¹⁾				Chip Enable address ⁽²⁾			R \bar{W}
	b7	b6	b5	b4	b3	b2	b1	b0
Device select code when addressing the memory array	1	0	1	0	E2	E1	E0	R \bar{W}
Device select code when accessing the Identification page	1	0	1	1	E2	E1	E0	R \bar{W}

1. The most significant bit, b7, is sent first.
2. E0, E1 and E2 are compared with the value read on input pins E0, E1 and E2.

When the device select code is received, the device only responds if the chip enable address is the same as the value on the chip enable (E2, E1, E0) inputs.

The 8th bit is the Read/Write bit (R \bar{W}). This bit is set to 1 for read and 0 for write operations.

If a match occurs on the device select code, the corresponding device gives an acknowledgement on serial data (SDA) during the 9th bit time. If the device does not match the device select code, it deselects itself from the bus, and goes into standby mode.



5 Instructions

5.1 Write operations

Following a start condition the bus master sends a device select code with the R/W bit (\overline{RW}) reset to 0. The device acknowledges this, as shown in [Figure 7](#), and waits for two address bytes. The device responds to each address byte with an acknowledge bit, and then waits for the data byte.

Table 4. Most significant address byte

A15	A14	A13	A12	A11	A10	A9	A8
-----	-----	-----	-----	-----	-----	----	----

Table 5. Least significant address byte

A7	A6	A5	A4	A3	A2	A1	A0
----	----	----	----	----	----	----	----

When the bus master generates a stop condition immediately after a data byte Ack bit (in the “10th bit” time slot), either at the end of a byte write or a page write, the internal write cycle t_W is triggered. A stop condition at any other time slot does not trigger the internal write cycle.

After the stop condition and the successful completion of an internal write cycle (t_W), the device internal address counter is automatically incremented to point to the next byte after the last modified byte.

During the internal write cycle, serial data (SDA) is disabled internally, and the device does not respond to any requests.

If the write control input (\overline{WC}) is driven high, the write instruction is not executed and the accompanying data bytes are *not* acknowledged, as shown in [Figure 8](#).



5.1.1 Byte write

After the device select code and the address bytes, the bus master sends one data byte. If the addressed location is write-protected, by write control (\overline{WC}) being driven high, the device replies with NoAck, and the location is not modified. If, instead, the addressed location is not write-protected, the device replies with Ack. The bus master terminates the transfer by generating a stop condition, as shown in Figure 7.

Figure 7. Write mode sequences with $\overline{WC} = 0$ (data write enabled)

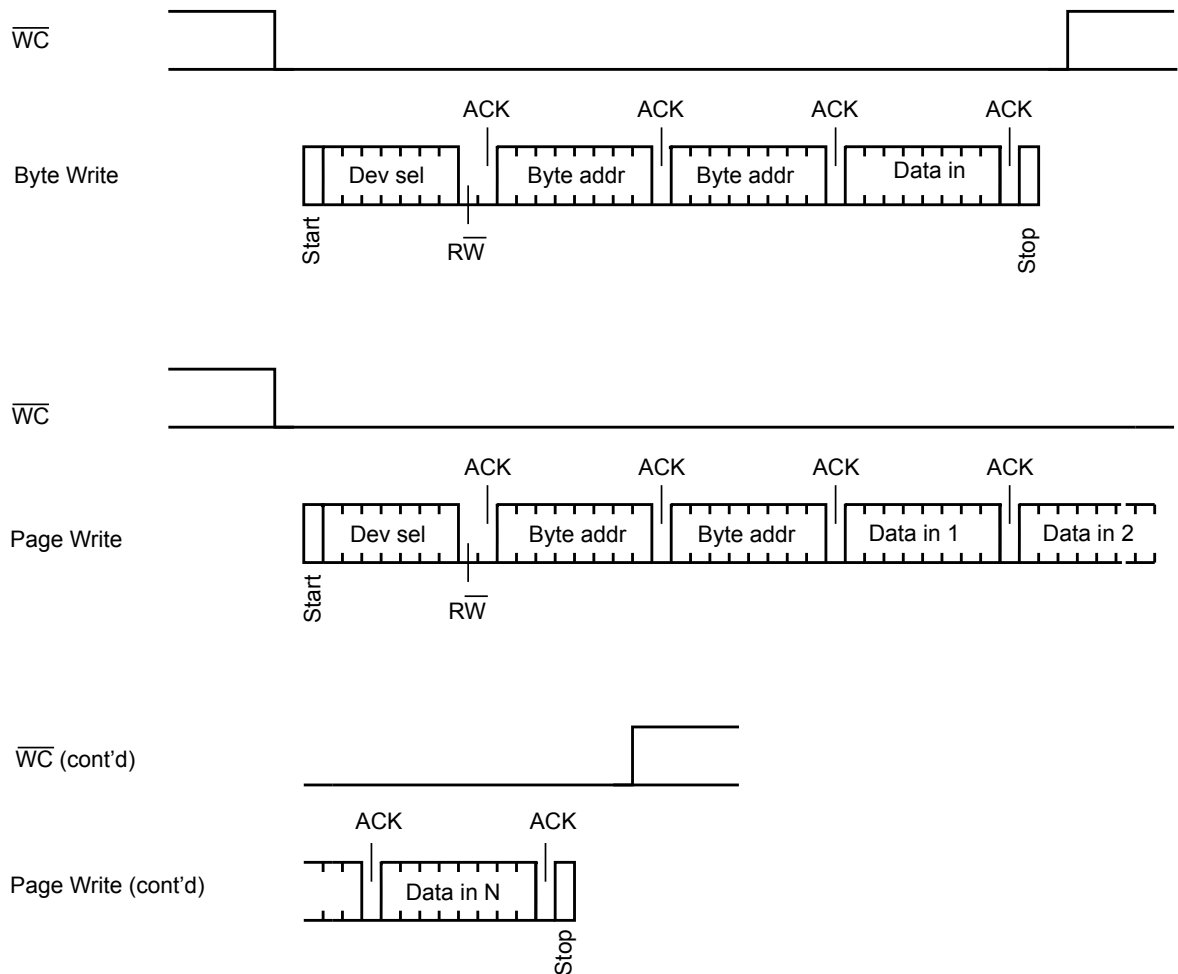



5.1.2 Page write

The page write mode allows up to 64 byte to be written in a single write cycle, provided that they are all located in the same page in the memory: that is, the most significant memory address bits, A15/A6, are the same. If more bytes are sent than will fit up to the end of the page, a “roll-over” occurs, i.e. the bytes exceeding the page end are written on the same page, from location 0.

The bus master sends from 1 to 64 byte of data, each of which is acknowledged by the device if write control (\overline{WC}) is low. If write control (\overline{WC}) is high, the contents of the addressed memory location are not modified, and each data byte is followed by a NoAck, as shown in Figure 8. After each transferred byte, the internal page address counter is incremented.

The transfer is terminated by the bus master generating a stop condition.

Figure 8. Write mode sequences with $\overline{WC} = 1$ (data write inhibited)

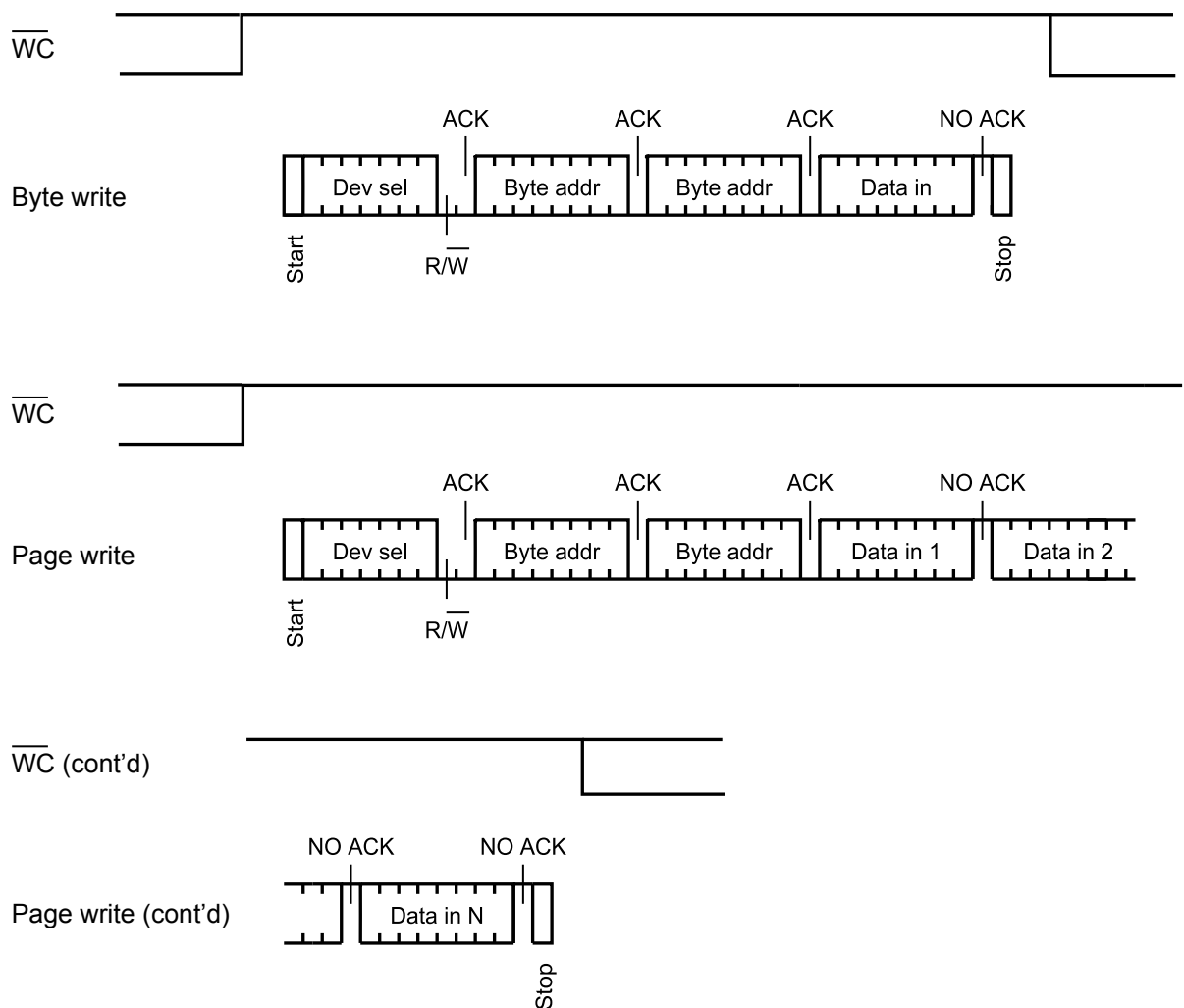



5.1.3 Write identification page (M24256-D only)

The identification page (64 byte) is an additional page which can be written and (later) permanently locked in read-only mode. It is written by issuing the write identification page instruction. This instruction uses the same protocol and format as page write (into memory array), except for the following differences:

- Device type identifier = 1011b
- MSB address bits A15/A6 are don't care except for address bit A10 which must be '0'. LSB address bits A5/A0 define the byte address inside the Identification page.

If the identification page is locked, the data bytes transferred during the write identification page instruction are not acknowledged (NoAck).

5.1.4 Lock identification page (M24256-D only)

The lock identification page instruction (Lock ID) permanently locks the identification page in read-only mode. The lock ID instruction is similar to byte write (into memory array) with the following specific conditions:

- Device type identifier = 1011b
- Address bit A10 must be '1'; all other address bits are don't care
- The data byte must be equal to the binary value xxxx xx1x, where x is don't care

5.1.5 ECC (error correction code) and write cycling

The error correction code (ECC) is an internal logic function which is transparent for the I²C communication protocol.

The ECC logic is implemented on each group of four EEPROM bytes (A group of four bytes is located at addresses $[4*N, 4*N+1, 4*N+2, 4*N+3]$, where N is an integer). Inside a group, if a single bit out of the four bytes happens to be erroneous during a read operation, the ECC detects this bit and replaces it with the correct value. The read reliability is therefore much improved.

Even if the ECC function is performed on groups of four bytes, a single byte can be written/cycled independently. In this case, the ECC function also writes/cycles the three other bytes located in the same group (A group of four bytes is located at addresses $[4*N, 4*N+1, 4*N+2, 4*N+3]$, where N is an integer). As a consequence, the maximum cycling budget is defined at group level and the cycling can be distributed over the 4 bytes of the group: the sum of the cycles seen by byte0, byte1, byte2 and byte3 of the same group must remain below the maximum value defined Table 11.



5.1.6 Minimizing write delays by polling on ACK

The maximum write time (t_w) is shown in AC characteristics tables in Section 8, but the typical time is shorter. To make use of this, a polling sequence can be used by the bus master.

The sequence, as shown in Figure 9, is:

- Initial condition: a write cycle is in progress.
- Step 1: the bus master issues a Start condition followed by a device select code (the first byte of the new instruction).
- Step 2: if the device is busy with the internal write cycle, no Ack is returned and the bus master goes back to step 1. If the device has terminated the internal write cycle, it responds with an Ack, indicating that the device is ready to receive the second part of the instruction (the first byte of this instruction having been sent during Step 1).

Figure 9. Write cycle polling flowchart using ACK

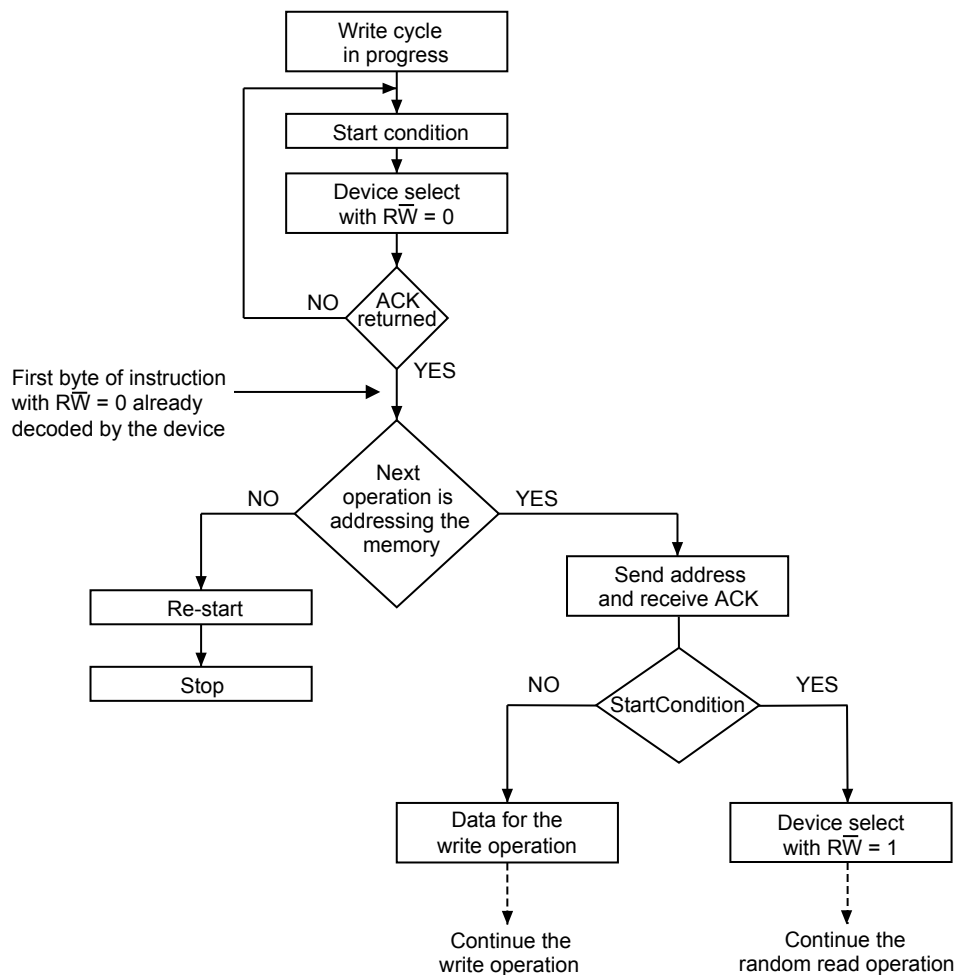

1. The seven most significant bits of the device select code of a random read (bottom right box in the figure) must be identical to the seven most significant bits of the device select code of the write (polling instruction in the figure).



5.2 Read operations

Read operations are performed independently of the state of the write control (\overline{WC}) signal.

After the successful completion of a read operation, the device internal address counter is incremented by one, to point to the next byte address.

For the read instructions, after each byte read (data out), the device waits for an acknowledgement (data in) during the 9th bit time. If the bus master does not acknowledge during this 9th time, the device terminates the data transfer and switches to its standby mode.

Figure 10. Read mode sequences

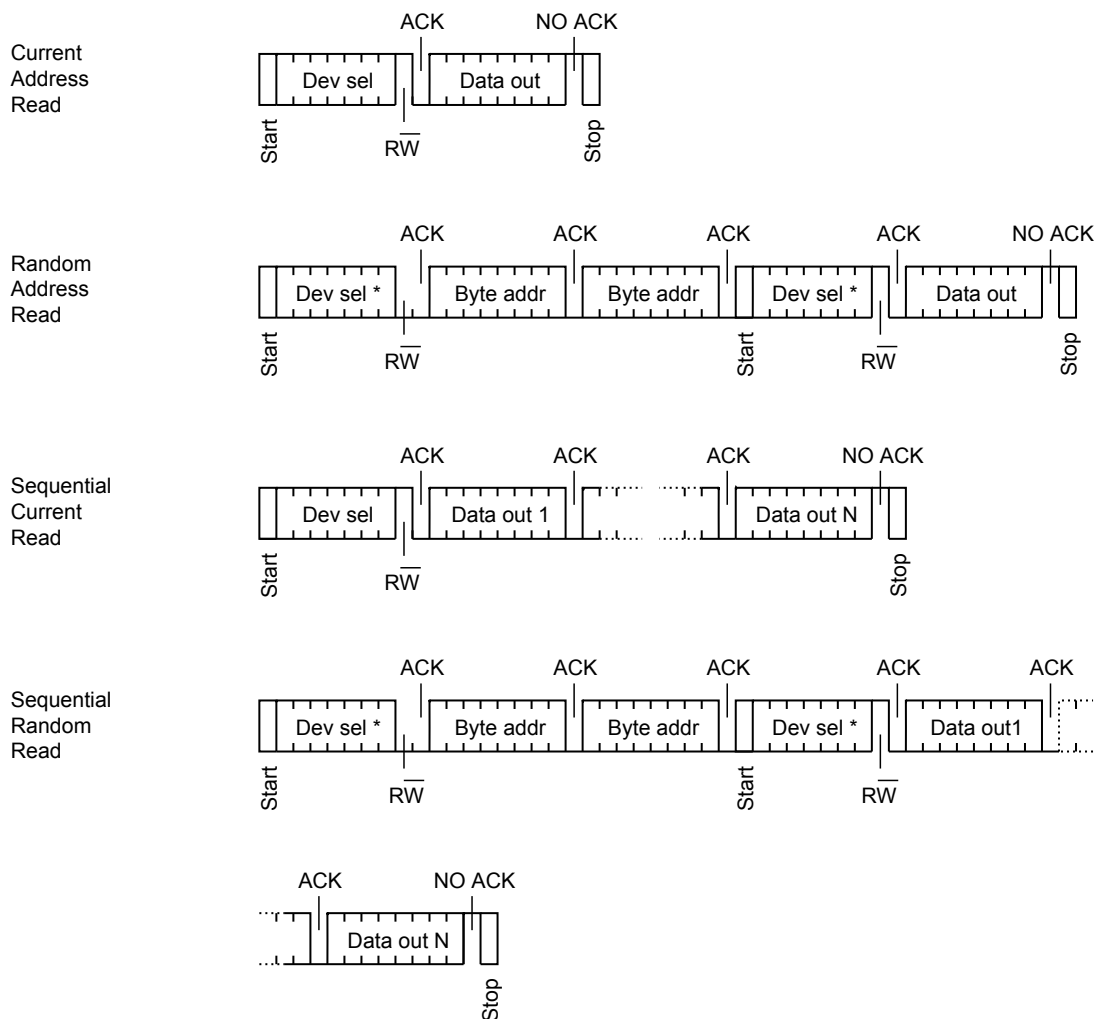



5.2.1 Random address read

A dummy write is first performed to load the address into this address counter (as shown in [Figure 10](#)) but without sending a stop condition. Then, the bus master sends another start condition, and repeats the device select code, with the \overline{RW} bit set to 1. The device acknowledges this, and outputs the contents of the addressed byte. The bus master must not acknowledge the byte, and terminates the transfer with a stop condition.

5.2.2 Current address read

For the current address read operation, following a start condition, the bus master only sends a device select code with the R/W bit set to 1. The device acknowledges this, and outputs the byte addressed by the internal address counter. The counter is then incremented. The bus master terminates the transfer with a stop condition, as shown in [Figure 10](#), without acknowledging the byte.

Note that the address counter value is defined by instructions accessing either the memory or the identification page. When accessing the Identification page, the address counter value is loaded with the byte location in the identification page, therefore the next current address read in the memory uses this new address counter value. When accessing the memory, it is safer to always use the random address read instruction (this instruction loads the address counter with the byte location to read in the memory, see [Section 5.2.1 Random address read](#)) instead of the current address Read instruction.

5.2.3 Sequential read

This operation can be used after a current address read or a random address read. The bus master does not acknowledge the data byte output, and sends additional clock pulses so that the device continues to output the next byte in sequence. To terminate the stream of bytes, the bus master must not acknowledge the last byte, and must generate a Stop condition, as shown in [Figure 10](#).

The output data comes from consecutive addresses, with the internal address counter automatically incremented after each byte output. After the last memory address, the address counter “rolls-over”, and the device continues to output data from memory address 00h.

5.3 Read identification page (M24256-D only)

The identification page (64 bytes) is an additional page which can be written and (later) permanently locked in Read-only mode.

The identification page can be read by issuing an read identification page instruction. This instruction uses the same protocol and format as the random address read (from memory array) with device type identifier defined as 1011b. The MSB address bits A15/A6 are don't care, the LSB address bits A5/A0 define the byte address inside the identification page. The number of bytes to read in the ID page must not exceed the page boundary (e.g.: when reading the identification page from location 10d, the number of bytes should be less than or equal to 54, as the ID page boundary is 64 bytes).



5.4 Read the lock status (M24256-D only)

The locked/unlocked status of the identification page can be checked by transmitting a specific truncated command [identification page write instruction + one data byte] to the device. The device returns an acknowledge bit if the identification page is unlocked, otherwise a NoAck bit if the identification page is locked.

Right after this, it is recommended to transmit to the device a start condition followed by a stop condition, so that:

- Start: the truncated command is not executed because the start condition resets the device internal logic,
- Stop: the device is then set back into standby mode by the stop condition.



6 Initial delivery state

The device is delivered with all the memory array bits and Identification page bits set to 1 (each byte contains FFh).



7 Maximum rating

Stressing the device outside the ratings listed in Table 6 may cause permanent damage to the device. These are stress ratings only, and operation of the device at these, or any other conditions outside those indicated in the operating sections of this specification, is not implied. Exposure to absolute maximum rating conditions for extended periods may affect device reliability.

Table 6. Absolute maximum ratings

Symbol	Parameter	Min.	Max.	Unit
-	Ambient operating temperature	-40	130	°C
T _{STG}	Storage temperature	-65	150	°C
T _{LEAD}	Lead temperature during soldering	see note ⁽¹⁾		°C
I _{OL}	DC output current (SDA = 0)	-	5	mA
V _{IO}	Input or output range	-0.50	6.5	V
V _{CC}	Supply voltage	-0.50	6.5	V
V _{ESD}	Electrostatic pulse (Human Body model) ⁽²⁾	-	4000	V

1. Compliant with JEDEC Std J-STD-020D (for small body, Sn-Pb or Pb-free assembly), the ST ECOPACK 7191395 specification, and the European directive on Restrictions of Hazardous Substances (RoHS directive 2011/65/EU of July 2011).
2. Positive and negative pulses applied on different combinations of pin connections, according to AEC-Q100-002 (compliant with ANSI/ESDA/JEDEC JS-001-2012 standard, C1=100 pF, R1=1500 Ω).



8 DC and AC parameters

This section summarizes the operating and measurement conditions, and the DC and AC characteristics of the device.

Table 7. Operating conditions (voltage range W)

Symbol	Parameter	Min.	Max.	Unit
V_{CC}	Supply voltage	2.5	5.5	V
T_A	Ambient operating temperature	-40	85	°C
f_C	Operating clock frequency	-	1	MHz

Table 8. Operating conditions (voltage range R)

Symbol	Parameter	Min.	Max.	Unit
V_{CC}	Supply voltage	1.8	5.5	V
T_A	Ambient operating temperature	-40	85	°C
f_C	Operating clock frequency	-	1	MHz

Table 9. Operating conditions (voltage range F)

Symbol	Parameter	Min.	Max.	Unit
V_{CC}	Supply voltage	1.7	5.5	V
T_A	Ambient operating temperature	-40	85	°C
f_C	Operating clock frequency	-	1	MHz

Table 10. AC measurement conditions

Symbol	Parameter	Min.	Max.	Unit
C_{bus}	Load capacitance	-	100	pF
-	SCL input rise/fall time, SDA input fall time	-	50	ns
-	Input levels	0.2 V_{CC} to 0.8 V_{CC}		V
-	Input and output timing reference levels	0.3 V_{CC} to 0.7 V_{CC}		V



Figure 11. AC measurement I/O waveform

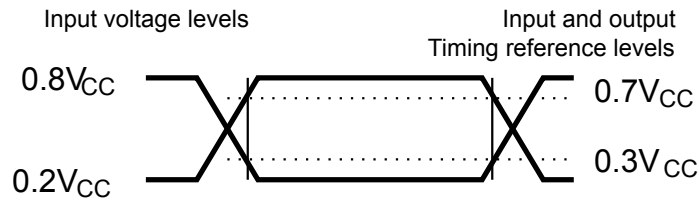

Table 11. Input parameters

Symbol	Parameter ⁽¹⁾	Test condition	Min.	Max.	Unit
C_{IN}	Input capacitance (SDA)	-	-	8	pF
C_{IN}	Input capacitance (other pins)	-	-	6	pF
Z_L	Input impedance (E2, E1, E0, \overline{WC}) ⁽²⁾	$V_{IN} < 0.3 V_{CC}$	30	-	k Ω
Z_H		$V_{IN} > 0.7 V_{CC}$	500	-	k Ω

1. Characterized only, not tested in production.
2. E2, E1, E0 input impedance when the memory is selected (after a Start condition).

Table 12. Cycling performance by groups of four bytes

Symbol	Parameter	Test condition	Max.	Unit
Ncycle	Write cycle endurance ⁽¹⁾	$T_A \leq 25^\circ\text{C}$, $V_{CC}(\text{min}) < V_{CC} < V_{CC}(\text{max})$	4,000,000	Write cycle ⁽²⁾
		$T_A = 85^\circ\text{C}$, $V_{CC}(\text{min}) < V_{CC} < V_{CC}(\text{max})$	1,200,000	

1. The write cycle endurance is defined by characterization and qualification. For devices embedding the ECC functionality (see ECC (error correction code) and write cycling), the write cycle endurance is defined for group of four bytes located at addresses $[4*N, 4*N+1, 4*N+2, 4*N+3]$ where N is an integer.
2. A Write cycle is executed when either a page write, a byte write, a write identification page or a lock identification page instruction is decoded. When using the byte write, the page write or the write identification page, refer also to Section 5.1.5 ECC (error correction code) and write cycling

Table 13. Memory cell data retention

Parameter	Test condition	Min.	Unit
Data retention ⁽¹⁾	$T_A = 55^\circ\text{C}$	200	Year

1. The data retention behaviour is checked in production, while the data retention limit defined in this table is extracted from characterization and qualification results.



Table 14. DC characteristics (M24256-BW, device grade 6)

Symbol	Parameter	Test conditions (in addition to those in Table 7)	Min.	Max.	Unit
I_{LI}	Input leakage current (SCL, SDA, E2, E1, E0)	$V_{IN} = V_{SS}$ or V_{CC} , device in Standby mode	-	± 2	μA
I_{LO}	Output leakage current	SDA in Hi-Z, external voltage applied on SDA: V_{SS} or V_{CC}	-	± 2	μA
I_{CC}	Supply current (Read)	$V_{CC} = 2.5 V$, $f_C = 400 kHz$ (rise/fall time < 50 ns)	-	1	mA
		$V_{CC} = 5.5 V$, $f_C = 400 kHz$ (rise/fall time < 50 ns)	-	2	
		$2.5 V \leq V_{CC} \leq 5.5 V$, $f_C = 1 MHz$ (rise/fall time < 50 ns)	-	2.5	
I_{CC0}	Supply current (Write)	During t_W , $2.5 V \leq V_{CC} \leq 5.5 V$	-	2 ⁽¹⁾	mA
I_{CC1}	Standby supply current	Device not selected ⁽²⁾ , $V_{IN} = V_{SS}$ or V_{CC} , $V_{CC} = 2.5 V$	-	2	μA
		Device not selected ⁽²⁾ , $V_{IN} = V_{SS}$ or V_{CC} , $V_{CC} = 5.5 V$	-	3	μA
V_{IL}	Input low voltage ⁽³⁾ (SCL, SDA, \overline{WC} , E2, E1, E0)	-	-0.45	$0.3 V_{CC}$	V
V_{IH}	Input high voltage (SCL, SDA)	-	$0.7 V_{CC}$	6.5	V
	Input high voltage (\overline{WC} , E2, E1, E0) ⁽⁴⁾	-	$0.7 V_{CC}$	$V_{CC}+0.6$	V
V_{OL}	Output low voltage	$I_{OL} = 2.1 mA$, $V_{CC} = 2.5 V$ or $I_{OL} = 3 mA$, $V_{CC} = 5.5 V$	-	0.4	V

1. Characterized value, not tested in production.
2. The device is not selected after power-up, after a read instruction (after the stop condition), or after the completion of the internal write cycle t_W (t_W is triggered by the correct decoding of a write instruction).
3. E_i inputs should be tied to V_{SS} (see Section 2.3 Chip enable (E2, E1, E0)).
4. E_i inputs should be tied to V_{CC} (see Section 2.3 Chip enable (E2, E1, E0)).



Table 15. DC characteristics (M24256-BR, M24256-DR device grade 6)

Symbol	Parameter	Test conditions ⁽¹⁾ (in addition to those in Table 8)	Min.	Max.	Unit
I_{LI}	Input leakage current (E0, E1, E2, SCL, SDA)	$V_{IN} = V_{SS}$ or V_{CC} , device in Standby mode	-	± 2	μA
I_{LO}	Output leakage current	SDA in Hi-Z, external voltage applied on SDA: V_{SS} or V_{CC}	-	± 2	μA
I_{CC}	Supply current (Read)	$V_{CC} = 1.8 V$, $f_c = 400 kHz$	-	0.8	mA
		$f_c = 1 MHz$	-	2.5	mA
I_{CC0}	Supply current (Write)	During t_W $1.8 V \leq V_{CC} \leq 2.5 V$	-	2 ⁽²⁾	mA
I_{CC1}	Standby supply current	Device not selected, ⁽³⁾ $V_{IN} = V_{SS}$ or V_{CC} , $V_{CC} = 1.8 V$	-	1	μA
V_{IL}	Input low voltage (SCL, SDA, \overline{WC} , E2, E1, E0) ⁽⁴⁾	$1.8 V \leq V_{CC} < 2.5 V$	-0.45	$0.25 V_{CC}$	V
V_{IH}	Input high voltage (SCL, SDA)	$1.8 V \leq V_{CC} < 2.5 V$	$0.75 V_{CC}$	6.5	V
	Input high voltage \overline{WC} , E2, E1, E0 ⁽⁵⁾	$1.8 V \leq V_{CC} < 2.5 V$	$0.75 V_{CC}$	$V_{CC} + 0.6$	V
V_{OL}	Output low voltage	$I_{OL} = 1 mA$, $V_{CC} = 1.8 V$	-	0.2	V

1. If the application uses the voltage range R device with $2.5 V < V_{CC} < 5.5 V$ and $-40^\circ C < T_A < +85^\circ C$, please refer to Table 14 instead of this table.
2. Characterized value, not tested in production.
3. The device is not selected after power-up, after a read instruction (after the stop condition), or after the completion of the internal write cycle t_W (t_W is triggered by the correct decoding of a write instruction).
4. Ei inputs should be tied to V_{SS} (see Section 2.3 Chip enable (E2, E1, E0)).
5. Ei inputs should be tied to V_{CC} (see Section 2.3 Chip enable (E2, E1, E0)).



Table 16. DC characteristics (M24256-BF, M24256-DF, device grade 6)

Symbol	Parameter	Test conditions ⁽¹⁾ (in addition to those in Table 9)	Min.	Max.	Unit
I_{LI}	Input leakage current (E0, E1, E2, SCL, SDA)	$V_{IN} = V_{SS}$ or V_{CC} device in Standby mode	-	± 2	μA
I_{LO}	Output leakage current	SDA in Hi-Z, external voltage applied on SDA: V_{SS} or V_{CC}	-	± 2	μA
I_{CC}	Supply current (Read)	$V_{CC} = 1.7 V$, $f_c = 400 kHz$	-	0.8	mA
		$f_c = 1 MHz$	-	2.5	
I_{CC0}	Supply current (Write)	During t_W $1.7 V < V_{CC} < 2.5 V$	-	2 ⁽²⁾	mA
I_{CC1}	Standby supply current	Device not selected, ⁽³⁾ $V_{IN} = V_{SS}$ or V_{CC} , $V_{CC} = 1.7 V$	-	1	μA
V_{IL}	Input low voltage (SCL, SDA, \overline{WC} , E2, E1, E0) ⁽⁴⁾	$1.7 V \leq V_{CC} < 2.5 V$	-0.45	$0.25 V_{CC}$	V
V_{IH}	Input high voltage (SCL, SDA)	$1.7 V \leq V_{CC} < 2.5 V$	$0.75 V_{CC}$	6.5	V
	Input high voltage (\overline{WC} , E2, E1, E0) ⁽⁵⁾	$1.7 V \leq V_{CC} < 2.5 V$	$0.75 V_{CC}$	$V_{CC} + 0.6$	V
V_{OL}	Output low voltage	$I_{OL} = 1 mA$, $V_{CC} = 1.7 V$	-	0.2	V

1. If the application uses the voltage range F device with $2.5 V < V_{CC} < 5.5 V$ and $-40^\circ C < T_A < +85^\circ C$, please refer to Table 14 instead of this table.
2. Characterized value, not tested in production.
3. The device is not selected after power-up, after a read instruction (after the stop condition), or after the completion of the internal write cycle t_W (t_W is triggered by the correct decoding of a write instruction).
4. Ei inputs should be tied to V_{SS} (see Section 2.3 Chip enable (E2, E1, E0)).
5. Ei inputs should be tied to V_{CC} (see Section 2.3 Chip enable (E2, E1, E0)).



Table 17. 400 kHz AC characteristics

Symbol	Alt.	Parameter	Min.	Max.	Unit
f_C	f_{SCL}	Clock frequency	-	400	kHz
t_{CHCL}	t_{HIGH}	Clock pulse width high	600	-	ns
t_{CLCH}	t_{LOW}	Clock pulse width low	1300	-	ns
$t_{QL1QL2}^{(1)}$	t_F	SDA (out) fall time	20 ⁽²⁾	300	ns
t_{XH1XH2}	t_R	Input signal rise time	(3)	(3)	ns
t_{XL1XL2}	t_F	Input signal fall time	(3)	(3)	ns
t_{DXCH}	$t_{SU:DAT}$	Data in set up time	100	-	ns
t_{CLDX}	$t_{HD:DAT}$	Data in hold time	0	-	ns
$t_{CLQX}^{(4)}$	t_{DH}	Data out hold time	100	-	ns
$t_{CLQV}^{(5)}$	t_{AA}	Clock low to next data valid (access time)	-	900	ns
t_{CHDL}	$t_{SU:STA}$	Start condition setup time	600	-	ns
t_{DLCL}	$t_{HD:STA}$	Start condition hold time	600	-	ns
t_{CHDH}	$t_{SU:STO}$	Stop condition set up time	600	-	ns
t_{DHDL}	t_{BUF}	Time between Stop condition and next Start condition	1300	-	ns
$t_{WLDL}^{(1)(6)}$	$t_{SU:WC}$	\overline{WC} set up time (before the Start condition)	0	-	μ s
$t_{DHWH}^{(1)(7)}$	$t_{HD:WC}$	\overline{WC} hold time (after the Stop condition)	1	-	μ s
t_W	t_{WR}	Internal Write cycle duration	-	5	ms
$t_{NS}^{(1)}$	-	Pulse width ignored (input filter on SCL and SDA) - single glitch	-	80	ns

1. Characterized only, not tested in production.

2. With $C_L = 10$ pF.

3. There is no min. or max. values for the input signal rise and fall times. It is however recommended by the I²C specification that the input signal rise and fall times be more than 20 ns and less than 300 ns when $f_C < 400$ kHz.

4. To avoid spurious Start and Stop conditions, a minimum delay is placed between SCL=1 and the falling or rising edge of SDA.

5. t_{CLQV} is the time (from the falling edge of SCL) required by the SDA bus line to reach either 0.3V_{CC} or 0.7V_{CC}, assuming that $R_{bus} \times C_{bus}$ time constant is within the values specified in Figure 12.

6. $\overline{WC}=0$ set up time condition to enable the execution of a WRITE command.

7. $\overline{WC}=0$ hold time condition to enable the execution of a WRITE command.



Table 18. 1 MHz AC characteristics

Symbol	Alt.	Parameter	Min.	Max.	Unit
f_C	f_{SCL}	Clock frequency	0	1	MHz
t_{CHCL}	t_{HIGH}	Clock pulse width high	260	-	ns
t_{CLCH}	t_{LOW}	Clock pulse width low	500	-	ns
t_{XH1XH2}	t_R	Input signal rise time	(1)	(1)	ns
t_{XL1XL2}	t_F	Input signal fall time	(1)	(1)	ns
$t_{QL1QL2}^{(2)}$	t_F	SDA (out) fall time	20 ⁽³⁾	120	ns
t_{DXCH}	$t_{SU:DAT}$	Data in setup time	50	-	ns
t_{CLDX}	$t_{HD:DAT}$	Data in hold time	0	-	ns
$t_{CLQX}^{(4)}$	t_{DH}	Data out hold time	100	-	ns
$t_{CLQV}^{(5)}$	t_{AA}	Clock low to next data valid (access time)	-	450	ns
t_{CHDL}	$t_{SU:STA}$	Start condition setup time	250	-	ns
t_{DLCL}	$t_{HD:STA}$	Start condition hold time	250	-	ns
t_{CHDH}	$t_{SU:STO}$	Stop condition setup time	250	-	ns
t_{DHDL}	t_{BUF}	Time between Stop condition and next Start condition	500	-	ns
$t_{WLDL}^{(2)(6)}$	$t_{SU:WC}$	\overline{WC} set up time (before the Start condition)	0	-	μs
$t_{DHWL}^{(2)(7)}$	$t_{HD:WC}$	\overline{WC} hold time (after the Stop condition)	1	-	μs
t_W	t_{WR}	Write time	-	5	ms
$t_{NS}^{(2)}$	-	Pulse width ignored (input filter on SCL and SDA)	-	50	ns

1. There is no min. or max. values for the input signal rise and fall times. It is however recommended by the I²C specification that the input signal rise and fall times be less than 120 ns when $f_C < 1$ MHz.
2. Characterized only, not tested in production.
3. With $C_L = 10$ pF.
4. To avoid spurious Start and Stop conditions, a minimum delay is placed between SCL=1 and the falling or rising edge of SDA.
5. t_{CLQV} is the time (from the falling edge of SCL) required by the SDA bus line to reach either 0.3 V_{CC} or 0.7 V_{CC} , assuming that the $R_{bus} \times C_{bus}$ time constant is within the values specified in Figure 13.
6. $\overline{WC}=0$ set up time condition to enable the execution of a WRITE command.
7. $\overline{WC}=0$ hold time condition to enable the execution of a WRITE command.



M24256-BW M24256-BR M24256-BF M24256-DR M24256-DF

DC and AC parameters

Figure 12. Maximum R_{bus} value versus bus parasitic capacitance (C_{bus}) for an I²C bus at maximum frequency $f_C = 400$ kHz

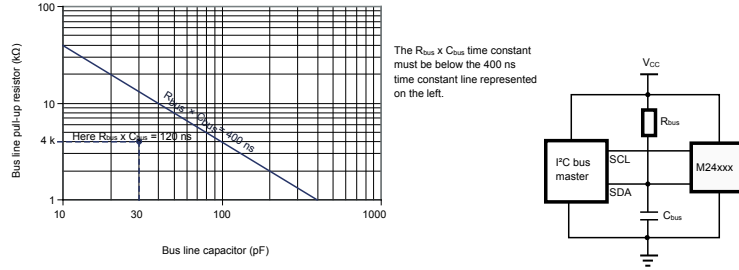
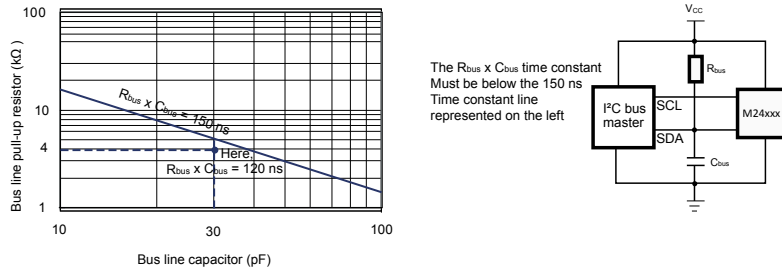

Figure 13. Maximum R_{bus} value versus bus parasitic capacitance (C_{bus}) for an I²C bus at maximum frequency $f_C = 1$ MHz





M24256-BW M24256-BR M24256-BF M24256-DR M24256-DF

DC and AC parameters

Figure 14. AC waveforms

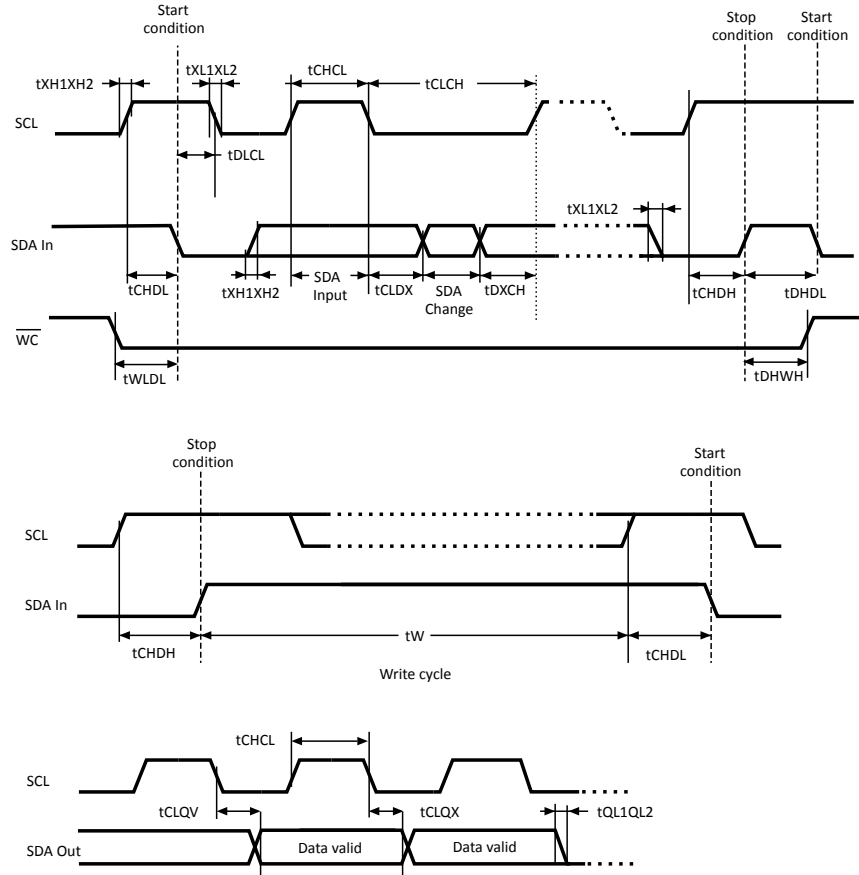



9 Package information

In order to meet environmental requirements, ST offers these devices in different grades of ECOPACK® packages, depending on their level of environmental compliance. ECOPACK® specifications, grade definitions and product status are available at: www.st.com. ECOPACK® is an ST trademark.

For die information concerning the M24256-BF delivered in unsawn wafer, please contact your nearest ST Sales Office.

9.1 UFDFPN8 (DFN8) package information

UFDFPN8 is an 8-lead, 2×3 mm, 0.55 mm thickness ultra thin profile fine pitch dual flat package.

Figure 15. UFDFPN8 - Outline

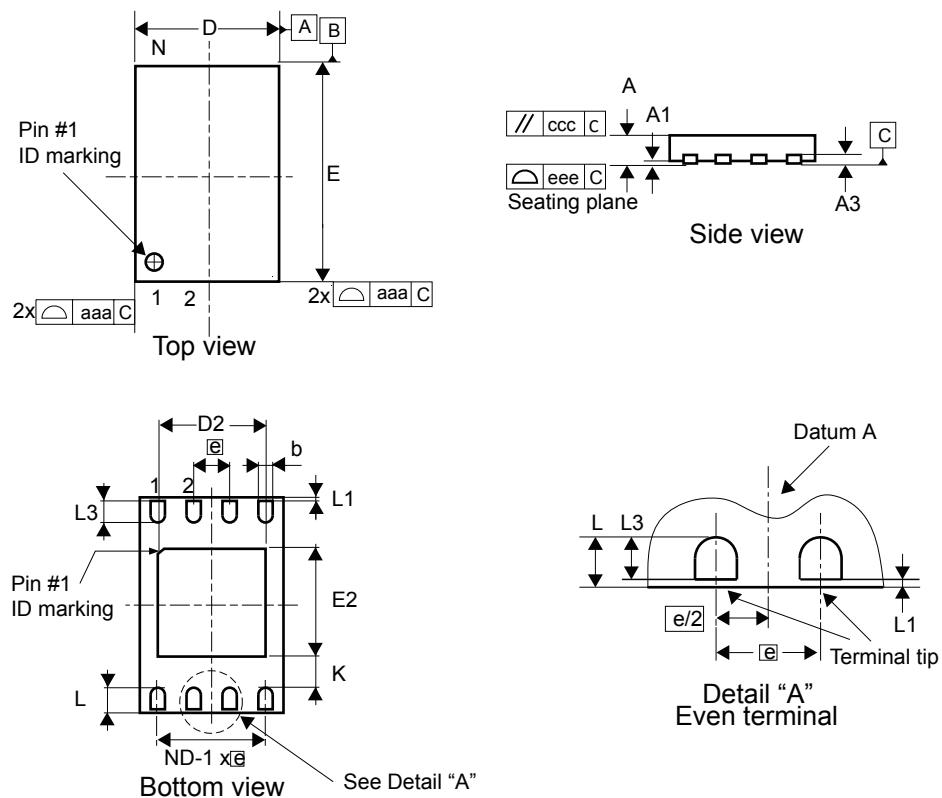

1. Maximum package warpage is 0.05 mm.
2. Exposed copper is not systematic and can appear partially or totally according to the cross section.
3. Drawing is not to scale.
4. The central pad (the area E2 by D2 in the above illustration) must be either connected to V_{SS} or left floating (not connected) in the end application.

Table 19. UFDFPN8 - Mechanical data

Symbol	millimeters			inches ⁽¹⁾		
	Min	Typ	Max	Min	Typ	Max
A	0.450	0.550	0.600	0.0177	0.0217	0.0236
A1	0.000	0.020	0.050	0.0000	0.0008	0.0020
b ⁽²⁾	0.200	0.250	0.300	0.0079	0.0098	0.0118
D	1.900	2.000	2.100	0.0748	0.0787	0.0827
D2	1.200	-	1.600	0.0472	-	0.0630
E	2.900	3.000	3.100	0.1142	0.1181	0.1220
E2	1.200	-	1.600	0.0472	-	0.0630
e	-	0.500	-	0.0197	-	-
K	0.300	-	-	0.0118	-	-
L	0.300	-	0.500	0.0118	-	0.0197
L1	-	-	0.150	-	-	0.0059
L3	0.300	-	-	0.0118	-	-
aaa	-	-	0.150	-	-	0.0059
bbb	-	-	0.100	-	-	0.0039
ccc	-	-	0.100	-	-	0.0039
ddd	-	-	0.050	-	-	0.0020
eee ⁽³⁾	-	-	0.080	-	-	0.0031

1. Values in inches are converted from mm and rounded to four decimal digits.
2. Dimension b applies to plated terminal and is measured between 0.15 and 0.30 mm from the terminal tip.
3. Applied for exposed die paddle and terminals. Exclude embedding part of exposed die paddle from measuring.

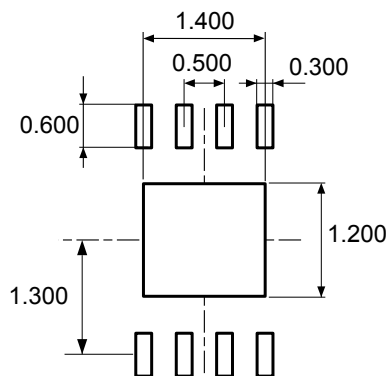
Figure 16. UFDFPN8 - Recommended footprint

1. Dimensions are expressed in millimeters.



9.2 TSSOP8 package information

TSSOP8 is an 8-lead thin shrink small outline, 3 x 6.4 mm, 0.65 mm pitch, package.

Figure 17. TSSOP8 – Outline

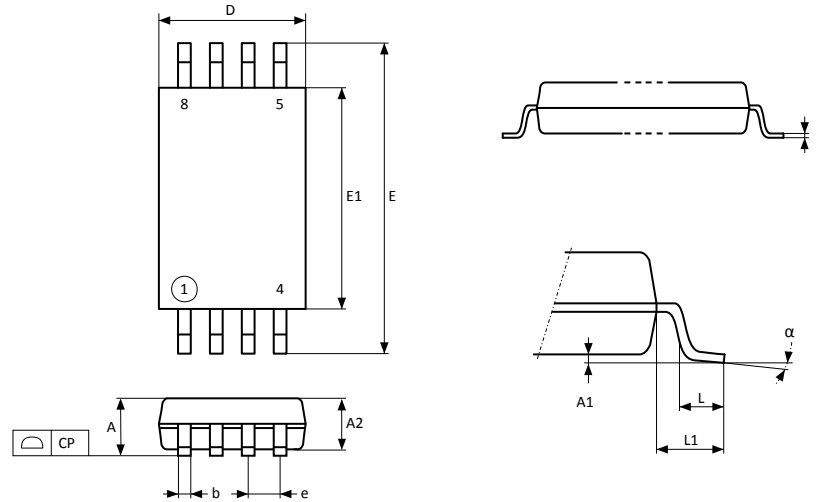

1. Drawing is not to scale.

Table 20. TSSOP8 – Mechanical data

Symbol	millimeters			inches ⁽¹⁾		
	Min.	Typ.	Max.	Min.	Typ.	Max.
A	-	-	1.200	-	-	0.0472
A1	0.050	-	0.150	0.0020	-	0.0059
A2	0.800	1.000	1.050	0.0315	0.0394	0.0413
b	0.190	-	0.300	0.0075	-	0.0118
c	0.090	-	0.200	0.0035	-	0.0079
CP	-	-	0.100	-	-	0.0039
D	2.900	3.000	3.100	0.1142	0.1181	0.1220
e	-	0.650	-	-	0.0256	-
E	6.200	6.400	6.600	0.2441	0.2520	0.2598
E1	4.300	4.400	4.500	0.1693	0.1732	0.1772
L	0.450	0.600	0.750	0.0177	0.0236	0.0295
L1	-	1.000	-	-	0.0394	-
α	0°	-	8°	0°	-	8°

1. Values in inches are converted from mm and rounded to four decimal digits.

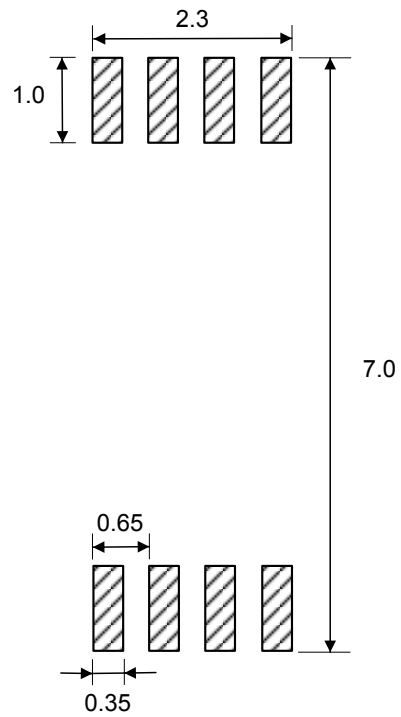
**Figure 18. TSSOP8 – Recommended footprint**

1. Dimensions are expressed in millimeters.



9.3 SO8N package information

SO8N is an 8-lead, 4.9 x 6 mm, plastic small outline, 150 mils body width, package.

Figure 19. SO8N – Outline

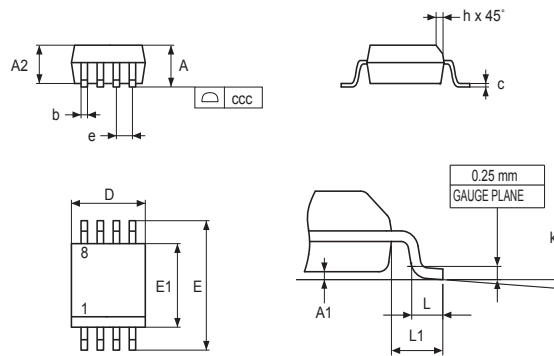

1. Drawing is not to scale.

Table 21. SO8N – Mechanical data

Symbol	millimeters			inches ⁽¹⁾		
	Min.	Typ.	Max.	Min.	Typ.	Max.
A	-	-	1.750	-	-	0.0689
A1	0.100	-	0.250	0.0039	-	0.0098
A2	1.250	-	-	0.0492	-	-
b	0.280	-	0.480	0.0110	-	0.0189
c	0.170	-	0.230	0.0067	-	0.0091
D	4.800	4.900	5.000	0.1890	0.1929	0.1969
E	5.800	6.000	6.200	0.2283	0.2362	0.2441
E1	3.800	3.900	4.000	0.1496	0.1535	0.1575
e	-	1.270	-	-	0.0500	-
h	0.250	-	0.500	0.0098	-	0.0197
k	0°	-	8°	0°	-	8°
L	0.400	-	1.270	0.0157	-	0.0500
L1	-	1.040	-	-	0.0409	-
ccc	-	-	0.100	-	-	0.0039

1. Values in inches are converted from mm and rounded to four decimal digits.



Figure 20. SO8N - Recommended footprint

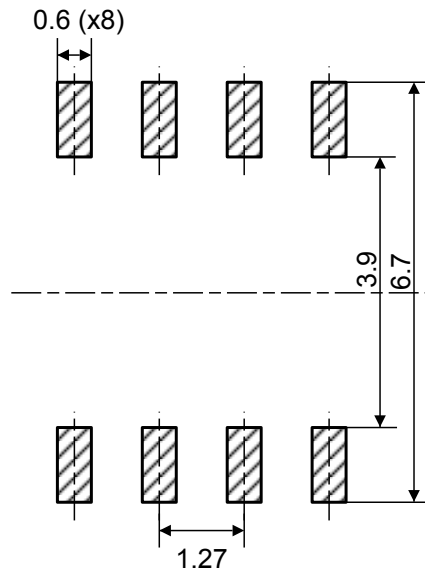

1. Dimensions are expressed in millimeters.

Table 22. WLCSP8 - Mechanical data

Symbol	millimeters			inches ⁽¹⁾		
	Min	Typ	Max	Min	Typ	Max
A	0.500	0.540	0.580	0.0197	0.0213	0.0228
A1	-	0.190	-	-	0.0075	-
A2	-	0.350	-	-	0.0138	-
b ⁽²⁾	-	0.270	-	-	0.0106	-
D	-	1.289	1.309	-	0.0507	0.0515
E	-	1.379	1.399	-	0.0542	0.0550
e	-	0.800	-	-	0.0315	-
e1	-	0.693	-	-	0.0273	-
e2	-	0.400	-	-	0.0157	-
e3	-	0.400	-	-	0.0157	-
F	-	0.342	-	-	0.0135	-
G	-	0.245	-	-	0.0096	-
H	-	0.245	-	-	0.0096	-
aaa	-	0.110	-	-	0.0043	-
bbb	-	0.110	-	-	0.0043	-
ccc	-	0.110	-	-	0.0043	-
ddd	-	0.060	-	-	0.0024	-
eee	-	0.060	-	-	0.0024	-

1. Values in inches are converted from mm and rounded to four decimal digits.
2. Dimension is measured at the maximum bump diameter parallel to primary datum Z.

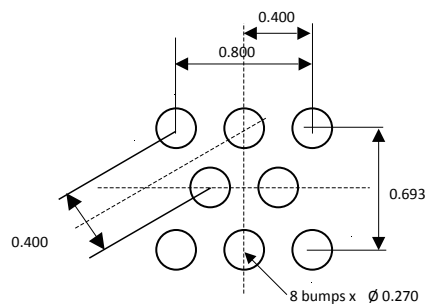
Figure 22. WLCSP8 - Recommended footprint

1. Dimensions are expressed in millimeters.



9.5 WLCSP8 (CU) package information

This WLCSP is a 8 balls, 1.289 x 1.376 mm, 0.4 mm pitch, with BSC, wafer level chip scale package

Figure 23. WLCSP8 - Outline

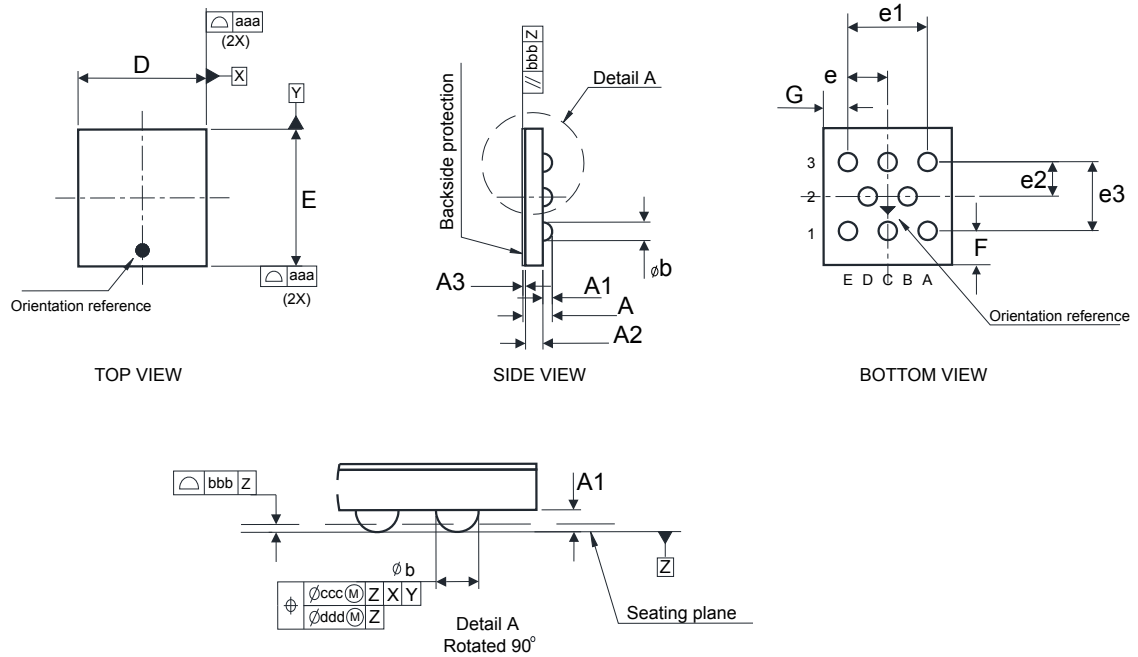

1. Drawing is not to scale.
2. Dimension is measured at the maximum bump diameter parallel to primary datum Z.
3. Primary datum Z and seating plane are defined by the spherical crowns of the bump.
4. Bump position designation per JESD 95-1, SPP-010.

Table 23. WLCSP8 - Mechanical data

	Millimeters			inches ⁽¹⁾		
	Min	Typ	Max	Min	Typ	Max
A	0.255	0.295	0.335	0.0100	0.0116	0.0132
A1	-	0.095	-	-	0.0037	-
A2	-	0.175	-	-	0.0069	-
A3	-	0.025	-	-	0.0010	-
b	-	0.185	-	-	0.0073	-
D	-	1.289	1.309	-	0.0507	0.0515
E	-	1.376	1.396	-	0.0542	0.0550
e	-	0.400	-	-	0.0157	-
e1	-	0.800	-	-	0.0315	-
e2	-	0.346	-	-	0.0136	-
e3	-	0.693	-	-	0.0273	-
F	-	0.342	-	-	0.0135	-
G	-	0.245	-	-	0.0096	-
aaa	-	0.110	-	-	0.0043	-
bbb	-	0.110	-	-	0.0043	-
ccc	-	0.110	-	-	0.0043	-
ddd	-	0.060	-	-	0.0024	-
eee	-	0.060	-	-	0.0024	-

1. Values in inches are converted from mm and rounded to the 4rd decimal place

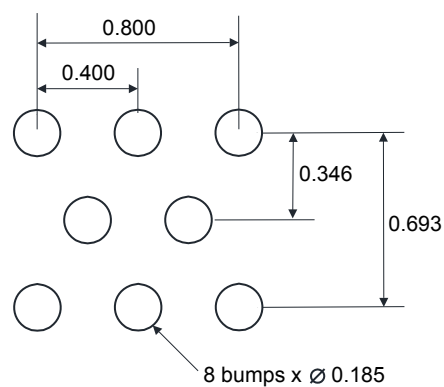
Figure 24. WLCSP8 - Recommended footprint

1. Dimensions are expressed in millimeters.



10 Ordering information

Table 24. Ordering information scheme

Example:	M24	256	- D	W	MN	6	T	P	/K
Device type									
M24 = I ² C serial access EEPROM									
Device function									
256 = 256 Kbit (32 K x 8 bit)									
Device family									
B = Without identification page D = With identification page									
Operating voltage									
W = V _{CC} = 2.5 V to 5.5 V R = V _{CC} = 1.8 V to 5.5 V F = V _{CC} = 1.7 V to 5.5 V									
Package⁽¹⁾									
MN = SO8 (150 mil width) DW = TSSOP8 (169 mil width) MC = UDFPN8 (DFN8) CS = WLCSP (chip scale package) CU = WLCSP Ultra-thin									
Device grade									
6 = Industrial: device tested with standard test flow over -40 to 85 °C									
Option									
T = Tape and reel packing blank = tube packing									
Plating technology									
P or G = ECOPACK2									
Process⁽²⁾									
/K = Manufacturing technology code									

1. ECOPACK2 (RoHS compliant and free of brominated, chlorinated and antimony oxide flame retardants).
2. These process letters appear on the device package (marking) and on the shipment box. Contact your nearest ST Sales Office for further information



Table 25. Ordering information scheme (unsawn wafer)

Example:	M24	256 -	B	F	K	W	20	I	/90
Device type⁽¹⁾									
M24 = I ² C serial access EEPROM									
Device function									
256 = 256 Kbit (32 K x 8 bit)									
Device family									
B = Without identification page									
Operating voltage									
F = V _{CC} = 1.7 V to 5.5 V									
Process									
K = F8H									
Delivery form									
W =Unsawn wafer									
Wafer thickness									
20 = Non-backlapped wafer									
Wafer testing									
I = Inkless test									
Device grade									
90 = -40°C to 85°C									

1. For all information concerning the M24256 delivered in unsawn wafer, please contact your nearest ST Sales Office.

Note: Parts marked as ES or E or accompanied by an Engineering Sample notification letter are not yet qualified and therefore not approved for use in production. ST is not responsible for any consequences resulting from such use. In no event will ST be liable for the customer using any of these engineering samples in production. ST's Quality department must be contacted prior to any decision to use these engineering samples to run a qualification activity.



Revision history

Table 26. Document revision history

Date	Revision	Changes
22-Jun-2012	26	<p>Datasheet revision 25 split into:</p> <ul style="list-style-type: none"> – M24256-125 datasheet for automotive products (range 3), – M24256-BW M24256-BR M24256-BF M24256-DR M24256-DF (this datasheet) for standard products (range 6). <p>Added:</p> <ul style="list-style-type: none"> – Reference M24256-DF – Table 1: Signal names, Table 12: Memory cell data retention <p>Updated:</p> <ul style="list-style-type: none"> – Table 17: 400 kHz AC characteristics and Table 18: 1 MHz AC characteristics: added set up and hold timing conditions on WC (t_{WLDL} and t_{DHWH}) – Figure 18: M24256-DFCS6TP/K, WLCSP 8-bump wafer-level chip scale package outline and Table 21: M24256-DFCS6TP/K, WLCSP 8-bump wafer-level chip scale package mechanical data – Cycling and data retention limits <p>Deleted:</p> <ul style="list-style-type: none"> – UFDFPN8, package revision MB
01-Aug-2012	27	Updated Figure 3: WLCSP connections and Figure 18: M24256-DFCS6TP/K, WLCSP 8-bump wafer-level chip scale package outline.
18-Sep-2012	28	<p>Changed title of Figure 3: WLCSP connections.</p> <p>Updated Section 5.2.2: Current Address Read.</p>
20-Nov-2012	29	Corrected “Device family” data in Table 24: Ordering information scheme.
17-Dec-2012	30	<p>Deleted note (3) under Table 3: Device select code.</p> <p>Modified ICCO condition in Table 15: DC characteristics (M24256-BR, M24256-DR device grade 6).</p> <p>Deleted incorrect table (Table 15. DC characteristics (M24256-R, device grade 6)).</p> <p>Updated package list in Table 24: Ordering information scheme.</p>
21-Feb-2014	31	<p>Updated Figure 3: WLCSP connections.</p> <p>Added notes 4. and 5. in Table 14 and notes 5. and 6. in Table 15 and Table 16</p>
17-Jun-2014	32	<p>Updated</p> <ul style="list-style-type: none"> – Figure 3, – note 1 on Table 12 – In Table 24 note 1 on Package and blank reference on Option.
01-Jun-2015	33	<p>Added:</p> <ul style="list-style-type: none"> – Unsawn wafer reference on cover page and Table 25: Ordering information scheme (unsawn wafer) – Figure 20: WLCSP (CS) - 8-bump, 1.289 x 1.376 mm, 0.4 mm pitch wafer level chip scale package recommended footprint – reference to Engineering samples <p>Updated:</p> <ul style="list-style-type: none"> – Section 2.6.2, Section 4.5

M24256-BW M24256-BR M24256-BF M24256-DR M24256-DF

Date	Revision	Changes
		<ul style="list-style-type: none"> – Note 2 on Table 6 – Table 18 – Note 2 on Figure 15 – Table 21 – Note 2 on Table 24 Removed: <ul style="list-style-type: none"> – Note on t_{NS} max value on Table 18
14-Mar-2018	34	Added WLCSP (CU) package in cover page and in Section 9: Package information, Table 2: Signals vs. bump position. Updated Table 10: AC measurement conditions, Table 22: WLCSP (CS)-8-bump, 1.289 x 1.376 mm, 0.4 mm pitch wafer level chip scale package mechanical data, Table 24: Ordering information scheme
19-Nov-2020	35	Updated: <ul style="list-style-type: none"> • Figure 5. Block diagram, • Table 6. Absolute maximum ratings, Table 12. Cycling performance by groups of four bytes, Table 14. DC characteristics (M24256-BW, device grade 6), Table 15. DC characteristics (M24256-BR, M24256-DR device grade 6), Table 16. DC characteristics (M24256-BF, M24256-DF, device grade 6), Table 18. 1 MHz AC characteristics, • note 1 in Table 13. Memory cell data retention • title of Figure 17. TSSOP8 – Outline and Table 20. TSSOP8 – Mechanical data; Figure 19. SO8N – Outline, Table 21. SO8N – Mechanical data and Figure 20. SO8N - Recommended footprint; Figure 21. WLCSP8 - Outline, Table 22. WLCSP8 - Mechanical data and Figure 22. WLCSP8 - Recommended footprint; Figure 23. WLCSP8 - Outline, Table 23. WLCSP8 - Mechanical data and Figure 24. WLCSP8 - Recommended footprint Added: <ul style="list-style-type: none"> • , Figure 18. TSSOP8 – Recommended footprint



Contents

1	Description	2
2	Signal description	4
2.1	Serial Clock (SCL)	4
2.2	Serial Data (SDA)	4
2.3	Chip Enable (E2, E1, E0)	4
2.4	Write Control (WC)	4
2.5	VSS (ground)	4
2.6	Supply voltage (VCC)	5
2.6.1	Operating supply voltage (VCC)	5
2.6.2	Power-up conditions	5
2.6.3	Device reset	5
2.6.4	Power-down conditions	5
3	Memory organization	6
4	Device operation	7
4.1	Start condition	8
4.2	Stop condition	8
4.3	Data input	8
4.4	Acknowledge bit (ACK)	8
4.5	Device addressing	9
5	Instructions	10
5.1	Write operations	10
5.1.1	Byte Write	11
5.1.2	Page Write	12
5.1.3	Write identification page (M24256-D only)	13
5.1.4	Lock identification page (M24256-D only)	13
5.1.5	ECC (Error Correction Code) and Write cycling	13
5.1.6	Minimizing Write delays by polling on ACK	14
5.2	Read operations	15
5.2.1	Random Address Read	16
5.2.2	Current Address Read	16



5.2.3	Sequential Read	16
5.3	Read identification page (M24256-D only)	16
5.4	Read the lock status (M24256-D only)	17
6	Initial delivery state	18
7	Maximum rating	19
8	DC and AC parameters	20
9	Package information	29
9.1	UFDFPN8 (DFN8) package information	29
9.2	TSSOP8 package information	31
9.3	SO8N package information	33
9.4	WLCSP8 (CS) package information	35
9.5	WLCSP8 (CU) package information	37
10	Ordering information	39
	Revision history	41



List of tables

Table 1.	Signal names	2
Table 2.	Signal vs. bump position	3
Table 3.	Device select code	9
Table 4.	Most significant address byte	10
Table 5.	Least significant address byte	10
Table 6.	Absolute maximum ratings	19
Table 7.	Operating conditions (voltage range W)	20
Table 8.	Operating conditions (voltage range R)	20
Table 9.	Operating conditions (voltage range F)	20
Table 10.	AC measurement conditions	20
Table 11.	Input parameters	21
Table 12.	Cycling performance by groups of four bytes	21
Table 13.	Memory cell data retention	21
Table 14.	DC characteristics (M24256-BW, device grade 6)	22
Table 15.	DC characteristics (M24256-BR, M24256-DR device grade 6)	23
Table 16.	DC characteristics (M24256-BF, M24256-DF, device grade 6)	24
Table 17.	400 kHz AC characteristics	25
Table 18.	1 MHz AC characteristics	26
Table 19.	UFDFPN8 - Mechanical data	30
Table 20.	TSSOP8 – Mechanical data	31
Table 21.	SO8N – Mechanical data	33
Table 22.	WLCSP8 - Mechanical data	36
Table 23.	WLCSP8 - Mechanical data	38
Table 24.	Ordering information scheme	39
Table 25.	Ordering information scheme (unsawn wafer)	40
Table 26.	Document revision history	41



List of figures

Figure 1.	Logic diagram	2
Figure 2.	8-pin package connections, top view	2
Figure 3.	WLCSP connections	3
Figure 4.	Chip enable inputs connection	4
Figure 5.	Block diagram	6
Figure 6.	I ² C bus protocol	7
Figure 7.	Write mode sequences with $\overline{WC} = 0$ (data write enabled)	11
Figure 8.	Write mode sequences with $\overline{WC} = 1$ (data write inhibited)	12
Figure 9.	Write cycle polling flowchart using ACK	14
Figure 10.	Read mode sequences	15
Figure 11.	AC measurement I/O waveform	21
Figure 12.	Maximum R_{bus} value versus bus parasitic capacitance (C_{bus}) for an I ² C bus at maximum frequency $f_C = 400$ kHz	27
Figure 13.	Maximum R_{bus} value versus bus parasitic capacitance (C_{bus}) for an I ² C bus at maximum frequency $f_C = 1$ MHz	27
Figure 14.	AC waveforms	28
Figure 15.	UFDFPN8 - Outline	29
Figure 16.	UFDFPN8 - Recommended footprint	30
Figure 17.	TSSOP8 – Outline	31
Figure 18.	TSSOP8 – Recommended footprint	32
Figure 19.	SO8N – Outline	33
Figure 20.	SO8N - Recommended footprint	34
Figure 21.	WLCSP8 - Outline	35
Figure 22.	WLCSP8 - Recommended footprint	36
Figure 23.	WLCSP8 - Outline	37
Figure 24.	WLCSP8 - Recommended footprint	38

**IMPORTANT NOTICE – PLEASE READ CAREFULLY**

STMicroelectronics NV and its subsidiaries (“ST”) reserve the right to make changes, corrections, enhancements, modifications, and improvements to ST products and/or to this document at any time without notice. Purchasers should obtain the latest relevant information on ST products before placing orders. ST products are sold pursuant to ST’s terms and conditions of sale in place at the time of order acknowledgement.

Purchasers are solely responsible for the choice, selection, and use of ST products and ST assumes no liability for application assistance or the design of Purchasers’ products.

No license, express or implied, to any intellectual property right is granted by ST herein.

Resale of ST products with provisions different from the information set forth herein shall void any warranty granted by ST for such product.

ST and the ST logo are trademarks of ST. For additional information about ST trademarks, please refer to www.st.com/trademarks. All other product or service names are the property of their respective owners.

Information in this document supersedes and replaces information previously supplied in any prior versions of this document.

© 2020 STMicroelectronics – All rights reserved

OUR CERTIFICATE

DiGi provide top-quality products and perfect service for customer worldwide through standardization, technological innovation and continuous improvement. DiGi through third-party certification, we stricly control the quality of products and services. Welcome your RFQ to

Email: Info@DiGi-Electronics.com



Tel: +00 852-30501935

RFQ Email: Info@DiGi-Electronics.com

DiGi is a global authorized distributor of electronic components.