

M34C02-LDW6TP Datasheet

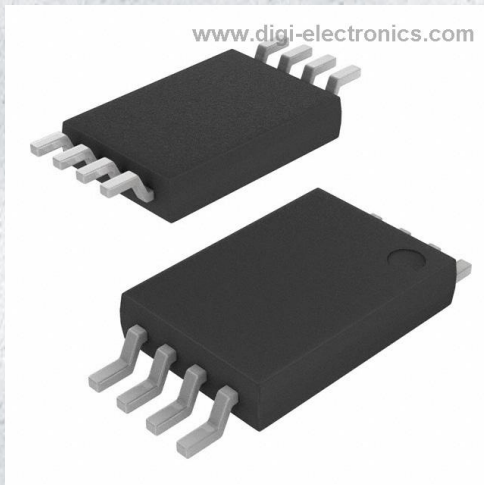

<https://www.DiGi-Electronics.com>

DiGi Electronics Part Number	M34C02-LDW6TP-DG
Manufacturer	STMicroelectronics
Manufacturer Product Number	M34C02-LDW6TP
Description	IC EEPROM 2KBIT I2C 8TSSOP
Detailed Description	EEPROM Memory IC 2Kbit I2C 400 kHz 900 ns 8-TSSOP

This model M34C02-LDW6TP is available at DiGi Electronics.

DiGi Electronics offers a global database of semiconductor and electronic component datasheets.

We welcome your inquiries regarding pricing, lead time, or other product-related questions.

 [Request a Quote](#)

 [Datasheet Search](#)



Tel: +00 852-30501935

RFQ Email: Info@DiGi-Electronics.com

DiGi is a global authorized distributor of electronic components.

Purchase and inquiry

Manufacturer Product Number:

M34C02-LDW6TP

Series:

-

DiGi-Electronics Programmable:

Not Verified

Memory Format:

EEPROM

Memory Size:

2Kbit

Memory Interface:

I2C

Write Cycle Time - Word, Page:

10ms

Voltage - Supply:

2.2V ~ 5.5V

Mounting Type:

Surface Mount

Supplier Device Package:

8-TSSOP

Manufacturer:

STMicroelectronics

Product Status:

Obsolete

Memory Type:

Non-Volatile

Technology:

EEPROM

Memory Organization:

256 x 8

Clock Frequency:

400 kHz

Access Time:

900 ns

Operating Temperature:

-40°C ~ 85°C (TA)

Package / Case:

8-TSSOP (0.173", 4.40mm Width)

Base Product Number:

M34C02

Environmental & Export classification

RoHS Status:

ROHS3 Compliant

REACH Status:

REACH Unaffected

HTSUS:

8542.32.0051

Moisture Sensitivity Level (MSL):

1 (Unlimited)

ECCN:

OBSOLETE



M34C02

2 Kbit Serial I²C Bus EEPROM For DIMM Serial Presence Detect

FEATURES SUMMARY

- Software Data Protection for lower 128 Bytes
- Two Wire I²C Serial Interface
- 100kHz and 400kHz Transfer Rates
- Single Supply Voltage:
 - 2.5 to 5.5V up to 400kHz for M34C02-W
 - 2.2 to 5.5V up to 400kHz for M34C02-L
 - 1.8 to 5.5V up to 400kHz for M34C02-R
 - 1.7 to 3.6V up to 100kHz for M34C02-F
- BYTE and PAGE WRITE (up to 16 bytes)
- RANDOM and SEQUENTIAL READ Modes
- Self-Timed Programming Cycle
- Automatic Address Incrementing
- Enhanced ESD/Latch-Up Protection
- More than 1 Million Erase/Write Cycles
- More than 40 Year Data Retention
- Packages
 - ECOPACK® (RoHS compliant)

Table 1. Product List

Reference	Part Number
M34C02	M34C02-W
	M34C02-L
	M34C02-R
	M34C02-F

Figure 1. Packages

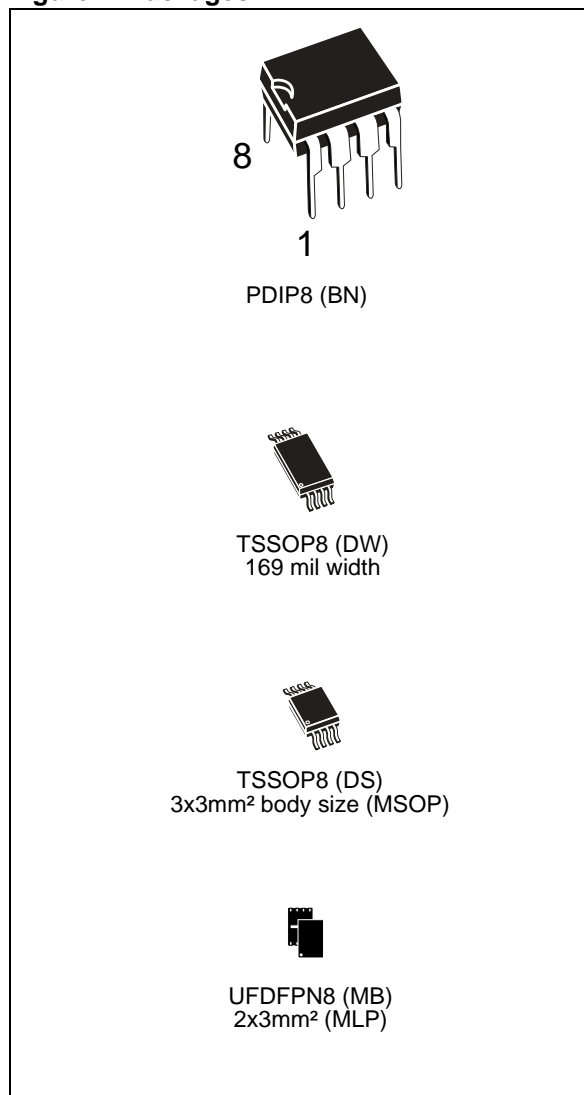

M34C02**TABLE OF CONTENTS**

FEATURES SUMMARY	1
Table 1. Product List	1
Figure 1. Packages	1
SUMMARY DESCRIPTION	4
Figure 2. Logic Diagram	4
Figure 3. DIP, TSSOP and MLP Connections (Top View)	4
Table 2. Signal Names	4
Device Internal Reset	5
SIGNAL DESCRIPTION	6
Serial Clock (SCL)	6
Serial Data (SDA)	6
Chip Enable (E0, E1, E2)	6
Figure 4. Chip Enable input connection	6
Write Control (\overline{WC})	6
Figure 5. Maximum RP Value versus Bus Parasitic Capacitance (C) for an I ² C Bus	6
Figure 6. I ² C Bus Protocol	7
Table 3. Device Select Code	7
DEVICE OPERATION	8
Start Condition	8
Stop Condition	8
Acknowledge Bit (ACK)	8
Data Input	8
Memory Addressing	8
Table 4. Operating Modes	8
Figure 7. Setting the Write Protection Register ($\overline{WC} = 0$)	9
Setting the Software Write-Protection	9
Figure 8. Result of Setting the Write Protection	9
Figure 9. Write Mode Sequences in a Non Write-Protected Area	10
Write Operations	10
Byte Write	10
Page Write	10
Figure 10. Write Cycle Polling Flowchart using ACK	11
Minimizing System Delays by Polling On ACK	11
Figure 11. Read Mode Sequences	12
Read Operations	12
Random Address Read	12
Current Address Read	12
Sequential Read	13
Acknowledge in Read Mode	13
USE WITHIN A DRAM DIMM	13

Programming the M34C02	13
Table 5. DRAM DIMM Connections.	13
INITIAL DELIVERY STATE	13
Figure 12. Serial Presence Detect Block Diagram	14
MAXIMUM RATING	15
Table 6. Absolute Maximum Ratings	15
DC AND AC PARAMETERS	16
Table 7. Operating Conditions (M34C02-W)	16
Table 8. Operating Conditions (M34C02-L)	16
Table 9. Operating Conditions (M34C02-R)	16
Table 10. Operating Conditions (M34C02-F)	16
Table 11. AC Measurement Conditions	17
Figure 13. AC Measurement I/O Waveform	17
Table 12. Input Parameters	17
Table 13. DC Characteristics (M34C02-W)	18
Table 14. DC Characteristics (M34C02-L)	18
Table 15. DC Characteristics (M34C02-R)	19
Table 16. DC Characteristics (M34C02-F)	19
Table 17. AC Characteristics (M34C02-W, M34C02-L, M34C02-R)	20
Table 18. AC Characteristics (M34C02-F)	20
Figure 14. AC Waveforms	21
PACKAGE MECHANICAL	22
Figure 15. PDIP8 – 8 pin Plastic DIP, 0.25mm lead frame, Package Outline	22
Table 19. PDIP8 – 8 pin Plastic DIP, 0.25mm lead frame, Package Mechanical Data	22
Figure 16. UDFPN8 (MLP8) 8-lead Ultra thin Fine pitch Dual Flat Package No lead 2x3mm ² , Package Outline	23
Table 20. UDFPN8 (MLP8) 8-lead Ultra thin Fine pitch Dual Flat Package No lead 2x3mm ² , Package Mechanical Data	23
Figure 17. TSSOP8 – 8 lead Thin Shrink Small Outline, Package Outline	24
Table 21. TSSOP8 – 8 lead Thin Shrink Small Outline, Package Mechanical Data	24
Figure 18. TSSOP8 3x3mm ² – 8 lead Thin Shrink Small Outline, 3x3mm ² body size, Outline	25
Table 22. TSSOP8 3x3mm ² – 8 lead Thin Shrink Small Outline, 3x3mm ² body size, Data	25
PART NUMBERING	26
Table 23. Ordering Information Scheme	26
REVISION HISTORY	27
Table 24. Revision History	27

M34C02

SUMMARY DESCRIPTION

The M34C02 is a 2Kbit serial EEPROM memory able to lock permanently the data in its first half (from location 00h to 7Fh). This facility has been designed specifically for use in DRAM DIMMs (dual interline memory modules) with Serial Presence Detect. All the information concerning the DRAM module configuration (such as its access speed, its size, its organization) can be kept write protected in the first half of the memory.

This bottom half of the memory area can be write-protected using a specially designed software write protection mechanism. By sending the device a specific sequence, the first 128 Bytes of the memory become permanently write protected. Care must be taken when using this sequence as its effect cannot be reversed. In addition, the device allows the entire memory area to be write protected, using the \overline{WC} input (for example by tying this input to V_{CC}).

These I²C-compatible electrically erasable programmable memory (EEPROM) devices are organized as 256x8 bits.

In order to meet environmental requirements, ST offers these devices in ECOPACK® packages.

ECOPACK® packages are Lead-free and RoHS compliant.

ECOPACK is an ST trademark. ECOPACK specifications are available at: www.st.com.

Figure 2. Logic Diagram

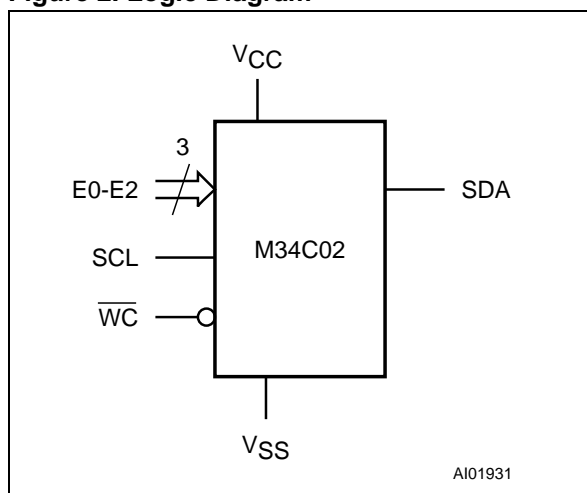

I²C uses a two wire serial interface, comprising a bi-directional data line and a clock line. The device carries a built-in 4-bit Device Type Identifier code (1010) in accordance with the I²C bus definition to

access the memory area and a second Device Type Identifier Code (0110) to access the Protection Register. These codes are used together with three chip enable inputs (E2, E1, E0) so that up to eight 2Kbit devices may be attached to the I²C bus and selected individually.

The device behaves as a slave device in the I²C protocol, with all memory operations synchronized by the serial clock. Read and Write operations are initiated by a START condition, generated by the bus master. The START condition is followed by a Device Select Code and \overline{RW} bit (as described in Table 3.), terminated by an acknowledge bit.

When writing data to the memory, the memory inserts an acknowledge bit during the 9th bit time, following the bus master's 8-bit transmission. When data is read by the bus master, the bus master acknowledges the receipt of the data byte in the same way. Data transfers are terminated by a STOP condition after an Ack for WRITE, and after a NoAck for READ.

Figure 3. DIP, TSSOP and MLP Connections (Top View)

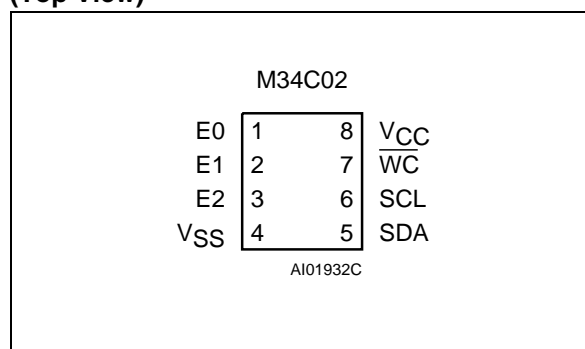

Note: See [PACKAGE MECHANICAL](#) section for package dimensions, and how to identify pin-1.

Table 2. Signal Names

E0, E1, E2	Chip Enable
SDA	Serial Data
SCL	Serial Clock
\overline{WC}	Write Control
VCC	Supply Voltage
VSS	Ground

Device Internal Reset

In order to prevent inadvertent Write operations during Power-up, a Power On Reset (POR) circuit is included. At Power-up (continuous rise up of VCC), the device will not respond to any instruction until the VCC has reached the Power On Reset threshold voltage (this threshold is lower than the minimum VCC operating voltage (as defined in [Table 7.](#) to [Table 10.](#)). When VCC has passed over the POR threshold, the device is reset and is in Standby Power mode.

Prior to selecting and issuing instructions to the memory, a valid and stable VCC voltage must be applied. This voltage must remain stable and valid until the end of the transmission of the instruction and, for a Write instruction, until the completion of the internal write cycle (t_w).

At Power-down (continuous decay of VCC), as soon as VCC drops from the normal operating voltage, below the Power On Reset threshold voltage, the device stops responding to any instruction sent to it.

M34C02

SIGNAL DESCRIPTION

Serial Clock (SCL)

This input signal is used to strobe all data in and out of the device. In applications where this signal is used by slave devices to synchronize the bus to a slower clock, the bus master must have an open drain output, and a pull-up resistor can be connected from Serial Clock (SCL) to V_{CC} . (Figure 5. indicates how the value of the pull-up resistor can be calculated). In most applications, though, this method of synchronization is not employed, and so the pull-up resistor is not necessary, provided that the bus master has a push-pull (rather than open drain) output.

Serial Data (SDA)

This bi-directional signal is used to transfer data in or out of the device. It is an open drain output that may be wire-OR'ed with other open drain or open collector signals on the bus. A pull up resistor must be connected from Serial Data (SDA) to V_{CC} . (Figure 5. indicates how the value of the pull-up resistor can be calculated).

Chip Enable (E0, E1, E2)

These input signals are used to set the value that is to be looked for on the three least significant bits (b3, b2, b1) of the 7-bit Device Select Code. These

inputs must be tied to V_{CC} or V_{SS} to establish the Device Select Code.

Figure 4. Chip Enable input connection

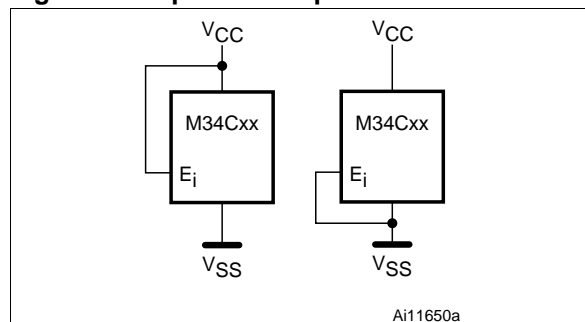

Write Control (\overline{WC})

This input signal is provided for protecting the contents of the whole memory from inadvertent write operations. Write Control (\overline{WC}) is used to enable (when driven Low) or disable (when driven High) write instructions to the entire memory area or to the Protection Register.

When Write Control (\overline{WC}) is tied Low or left unconnected, the write protection of the first half of the memory is determined by the status of the Protection Register.

Figure 5. Maximum RP Value versus Bus Parasitic Capacitance (C) for an I²C Bus

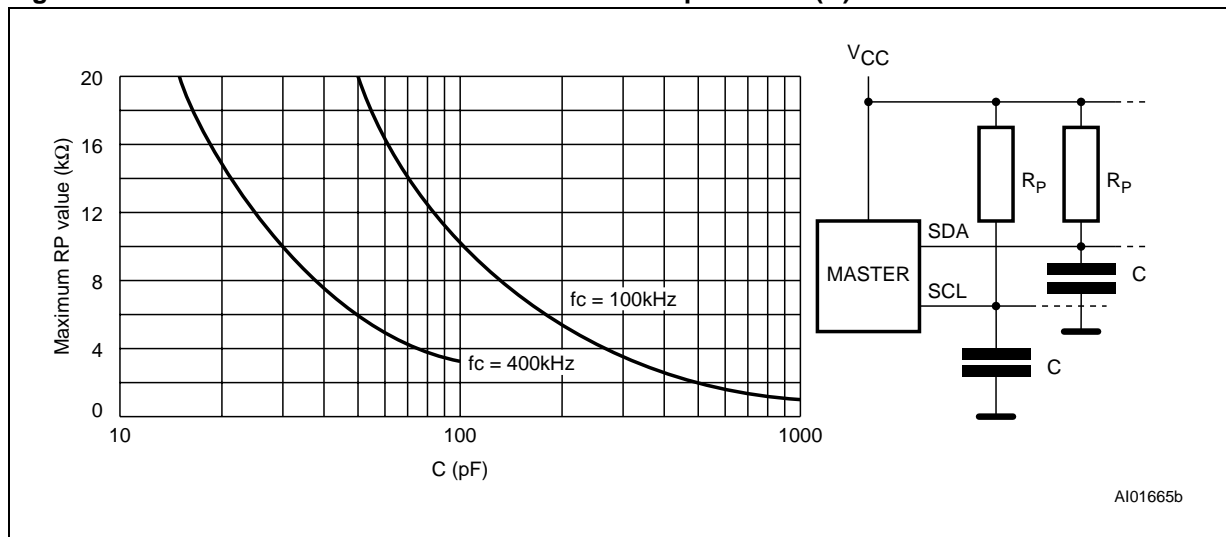

Figure 6. I²C Bus Protocol

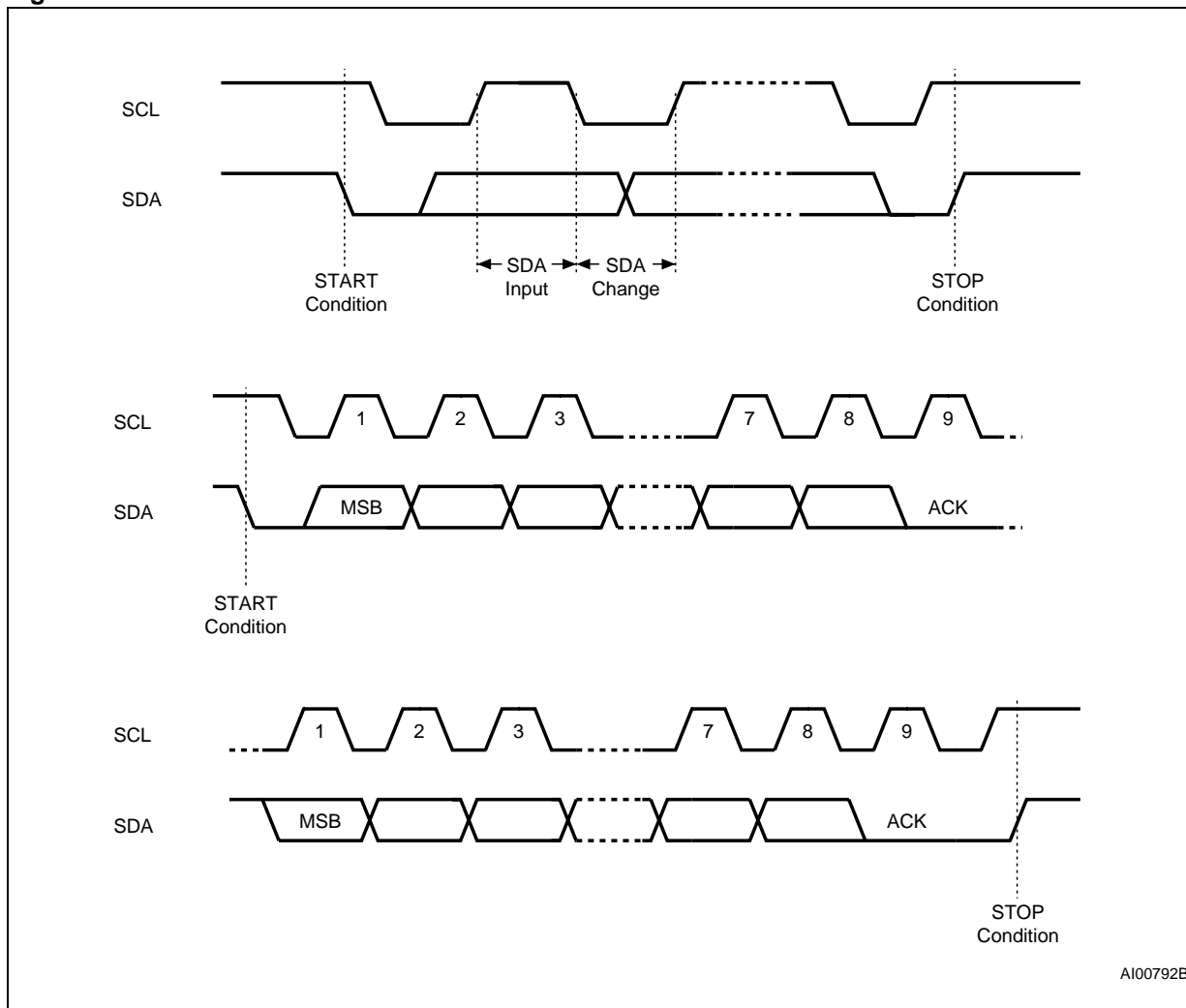

Table 3. Device Select Code

	Device Type Identifier ¹				Chip Enable Address ²			R \bar{W}
	b7	b6	b5	b4	b3	b2	b1	b0
Memory Area Select Code (two arrays)	1	0	1	0	E2	E1	E0	R \bar{W}
Protection Register Select Code	0	1	1	0	E2	E1	E0	R \bar{W}

Note: 1. The most significant bit, b7, is sent first.

2. E0, E1 and E2 are compared against the respective external pins on the memory device.

M34C02

DEVICE OPERATION

The device supports the I²C protocol. This is summarized in Figure 6.. Any device that sends data on to the bus is defined to be a transmitter, and any device that reads the data to be a receiver. The device that controls the data transfer is known as the bus master, and the other as the slave device. A data transfer can only be initiated by the bus master, which will also provide the serial clock for synchronization. The memory device is always a slave in all communication.

Start Condition

Start is identified by a falling edge of Serial Data (SDA) while Serial Clock (SCL) is stable in the High state. A Start condition must precede any data transfer command. The device continuously monitors (except during a Write cycle) Serial Data (SDA) and Serial Clock (SCL) for a Start condition, and will not respond unless one is given.

Stop Condition

Stop is identified by a rising edge of Serial Data (SDA) while Serial Clock (SCL) is stable and driven High. A Stop condition terminates communication between the device and the bus master. A Read command that is followed by NoAck can be followed by a Stop condition to force the device into the Stand-by mode. A Stop condition at the end of a Write command triggers the internal EEPROM Write cycle.

Acknowledge Bit (ACK)

The acknowledge bit is used to indicate a successful byte transfer. The bus transmitter, whether it be bus master or slave device, releases Serial Data (SDA) after sending eight bits of data. During the 9th clock pulse period, the receiver pulls Serial Data (SDA) Low to acknowledge the receipt of the eight data bits.

Data Input

During data input, the device samples Serial Data (SDA) on the rising edge of Serial Clock (SCL). For correct device operation, Serial Data (SDA) must be stable during the rising edge of Serial Clock (SCL), and the Serial Data (SDA) signal must change *only* when Serial Clock (SCL) is driven Low.

Memory Addressing

To start communication between the bus master and the slave device, the bus master must initiate a Start condition. Following this, the bus master sends the Device Select Code, shown in Table 3. (on Serial Data (SDA), most significant bit first).

The Device Select Code consists of a 4-bit Device Type Identifier, and a 3-bit Chip Enable "Address" (E2, E1, E0). To address the memory array, the 4-bit Device Type Identifier is 1010b; to address the Protection Register, it is 0110b.

Up to eight memory devices can be connected on a single I²C bus. Each one is given a unique 3-bit code on the Chip Enable (E0, E1, E2) inputs. When the Device Select Code is received, the device only responds if the Chip Enable Address is the same as the value on the Chip Enable (E0, E1, E2) inputs.

The 8th bit is the Read/Write bit (\overline{RW}). This bit is set to 1 for Read and 0 for Write operations.

If a match occurs on the Device Select code, the corresponding device gives an acknowledgment on Serial Data (SDA) during the 9th bit time. If the device does not match the Device Select code, it deselected itself from the bus, and goes into Stand-by mode.

Table 4. Operating Modes

Mode	\overline{RW} bit	\overline{WC} ¹	Bytes	Initial Sequence
Current Address Read	1	X	1	START, Device Select, $\overline{RW} = 1$
Random Address Read	0	X	1	START, Device Select, $\overline{RW} = 0$, Address
	1	X		reSTART, Device Select, $\overline{RW} = 1$
Sequential Read	1	X	≥ 1	Similar to Current or Random Address Read
Byte Write	0	V_{IL}	1	START, Device Select, $\overline{RW} = 0$
Page Write	0	V_{IL}	≤ 16	START, Device Select, $\overline{RW} = 0$

Note: 1. X = V_{IH} or V_{IL} .

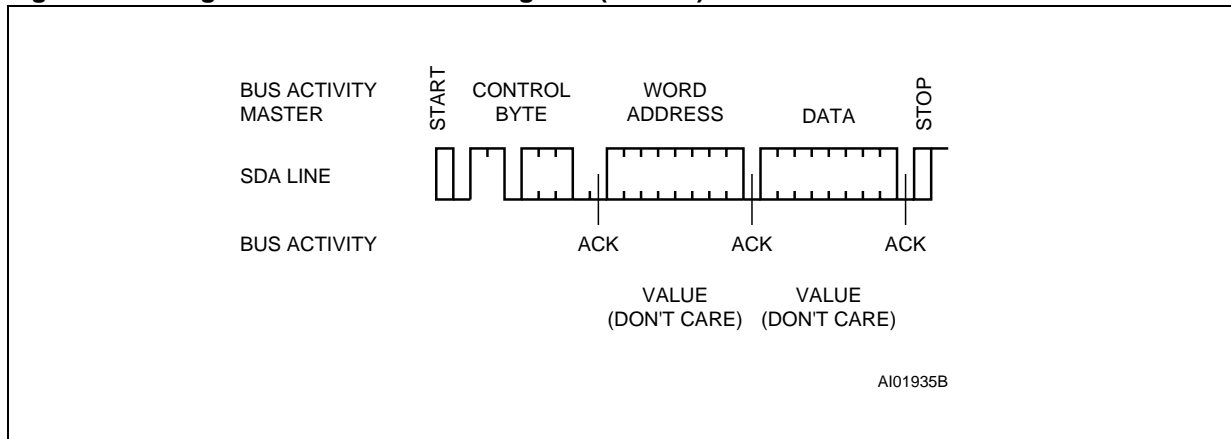
Figure 7. Setting the Write Protection Register ($\overline{WC} = 0$)

Setting the Software Write-Protection

The M34C02 has a hardware write-protection feature, using the Write Control (\overline{WC}) signal. This signal can be driven High or Low, and must be held constant for the whole instruction sequence. When Write Control (\overline{WC}) is held Low, the whole memory array (addresses 00h to FFh) is write protected. When Write Control (\overline{WC}) is held High, the write protection of the memory array is dependent on whether software write-protection has been set.

Software write-protection allows the bottom half of the memory area (addresses 00h to 7Fh) to be permanently write protected irrespective of subsequent states of the Write Control (\overline{WC}) signal.

The write protection feature is activated by writing once to the Protection Register. The Protection

Register is accessed with the device select code set to 0110b (as shown in Table 3.), and the E2, E1 and E0 bits set according to the states being applied on the E2, E1 and E0 signals. As for any other write command, Write Control (\overline{WC}) needs to be held Low. Address and data bytes must be sent with this command, but their values are all ignored, and are treated as Don't Care. Once the Protection Register has been written, the write protection of the first 128 Bytes of the memory is enabled, and it is not possible to unprotect these 128 Bytes, even if the device is powered off and on, and regardless the state of Write Control (\overline{WC}).

When the Protection Register has been written, the M34C02 no longer responds to the device type identifier 0110b in either read or write mode.

Figure 8. Result of Setting the Write Protection

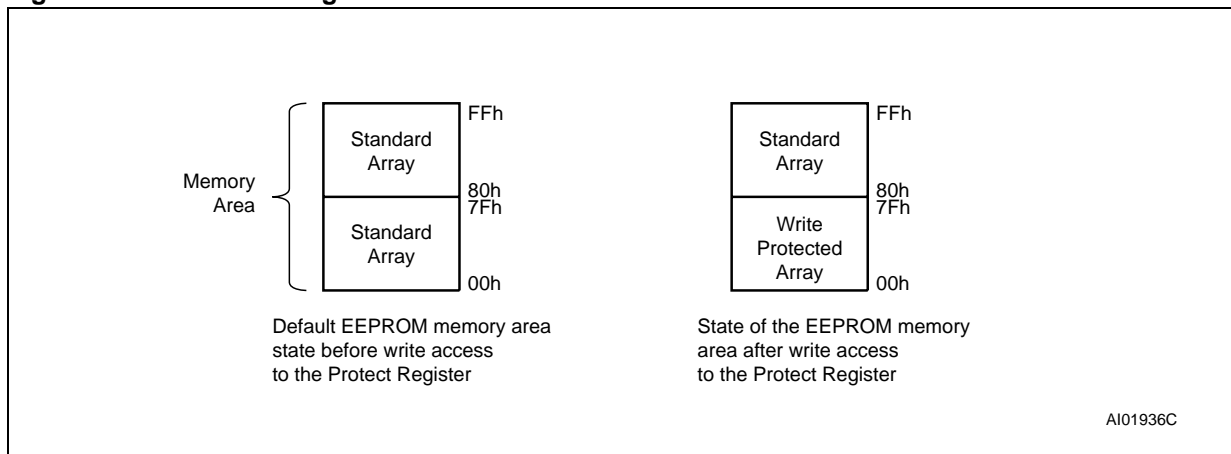

M34C02

Figure 9. Write Mode Sequences in a Non Write-Protected Area

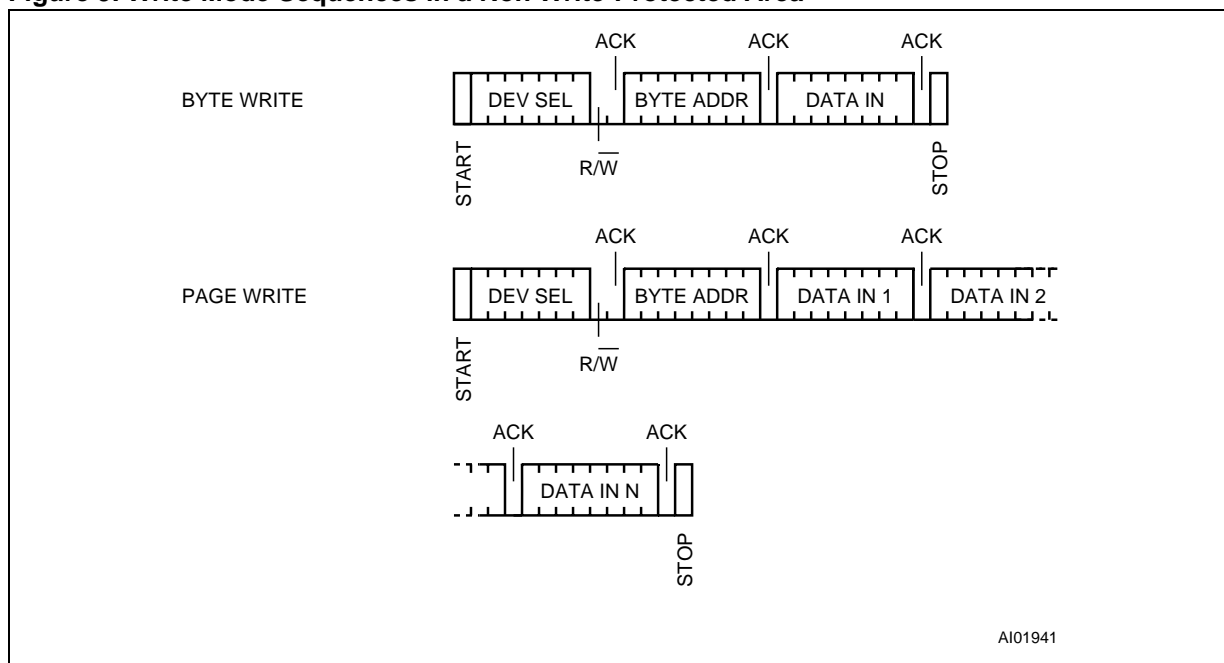

Write Operations

Following a Start condition the bus master sends a Device Select Code with the R/W bit reset to 0. The device acknowledges this, as shown in Figure 9., and waits for an address byte. The device responds to the address byte with an acknowledge bit, and then waits for the data byte.

When the bus master generates a Stop condition immediately after the Ack bit (in the “10th bit” time slot), either at the end of a Byte Write or a Page Write, the internal memory Write cycle is triggered. A Stop condition at any other time slot does not trigger the internal Write cycle.

During the internal Write cycle, Serial Data (SDA) and Serial Clock (SCL) are ignored, and the device does not respond to any requests.

Byte Write

After the Device Select Code and the address byte, the bus master sends one data byte. If the addressed location is hardware write-protected, the device replies to the data byte with NoAck, and the location is not modified. If, instead, the addressed location is not Write-protected, the device

replies with Ack. The bus master terminates the transfer by generating a Stop condition, as shown in Figure 9..

Page Write

The Page Write mode allows up to 16 bytes to be written in a single Write cycle, provided that they are all located in the same page in the memory: that is, the most significant memory address bits are the same. If more bytes are sent than will fit up to the end of the page, a condition known as ‘roll-over’ occurs. This should be avoided, as data starts to become overwritten in an implementation dependent way.

The bus master sends from 1 to 16 bytes of data, each of which is acknowledged by the device if Write Control (WC) is Low. If the addressed location is hardware write-protected, the device replies to the data byte with NoAck, and the locations are not modified. After each byte is transferred, the internal byte address counter (the 4 least significant address bits only) is incremented. The transfer is terminated by the bus master generating a Stop condition.

Figure 10. Write Cycle Polling Flowchart using ACK

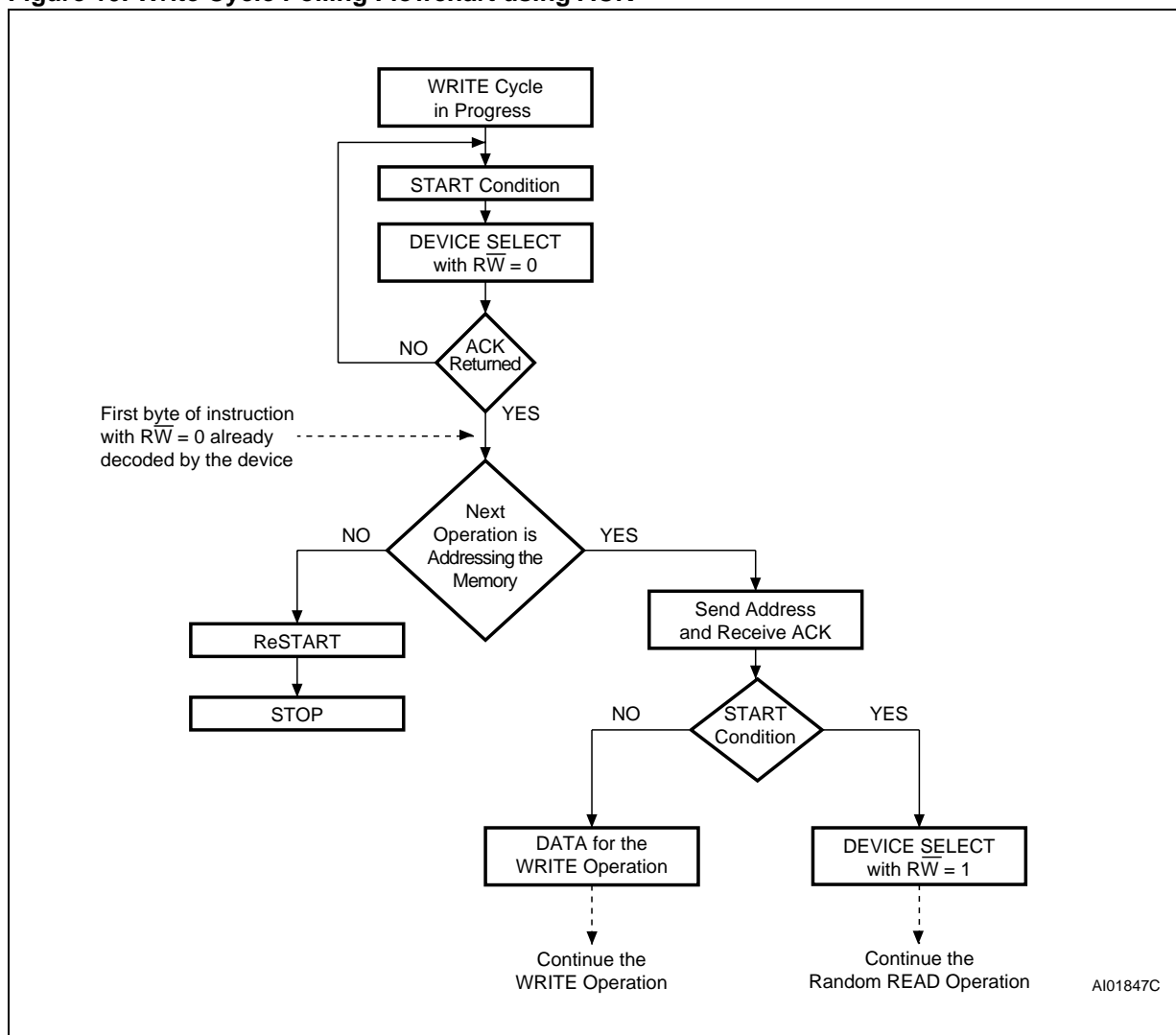

Minimizing System Delays by Polling On ACK

During the internal Write cycle, the device disconnects itself from the bus, and writes a copy of the data from its internal latches to the memory cells. The maximum Write time (t_w) is shown in [Table 17](#) and [Table 18](#), but the typical time is shorter. To make use of this, a polling sequence can be used by the bus master.

The sequence, as shown in [Figure 10](#), is:

- Initial condition: a Write cycle is in progress.
- Step 1: the bus master issues a Start condition followed by a Device Select Code (the first byte of the new instruction).
- Step 2: if the device is busy with the internal Write cycle, no Ack will be returned and the bus master goes back to Step 1. If the device has terminated the internal Write cycle, it responds with an Ack, indicating that the device is ready to receive the second part of the instruction (the first byte of this instruction having been sent during Step 1).

M34C02

Figure 11. Read Mode Sequences

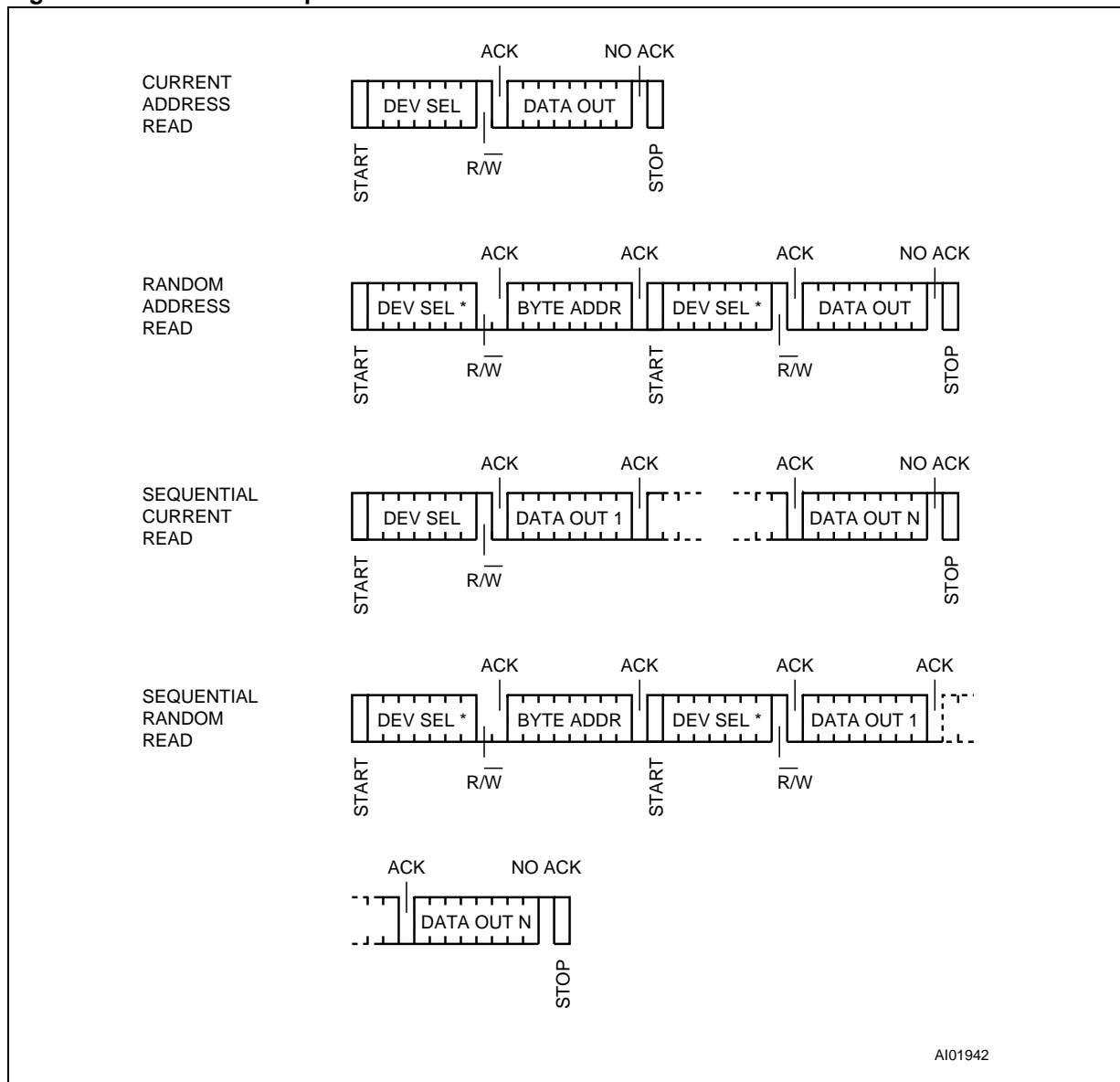

Note: 1. The seven most significant bits of the Device Select Code of a Random Read (in the 1st and 3rd bytes) must be identical.

Read Operations

Read operations are performed independently of whether hardware or software protection has been set.

The device has an internal address counter which is incremented each time a byte is read.

Random Address Read

A dummy Write is first performed to load the address into this address counter (as shown in Figure 11.) but *without* sending a Stop condition. Then, the bus master sends another Start condition, and repeats the Device Select Code, with the R/W bit set to 1. The device acknowledges this,

and outputs the contents of the addressed byte. The bus master must *not* acknowledge the byte, and terminates the transfer with a Stop condition.

Current Address Read

For the Current Address Read operation, following a Start condition, the bus master only sends a Device Select Code with the R/W bit set to 1. The device acknowledges this, and outputs the byte addressed by the internal address counter. The counter is then incremented. The bus master terminates the transfer with a Stop condition, as shown in Figure 11., *without* acknowledging the byte.

Sequential Read

This operation can be used after a Current Address Read or a Random Address Read. The bus master *does* acknowledge the data byte output, and sends additional clock pulses so that the device continues to output the next byte in sequence. To terminate the stream of bytes, the bus master must *not* acknowledge the last byte, and *must* generate a Stop condition, as shown in [Figure 11](#).

The output data comes from consecutive addresses, with the internal address counter automatically incremented after each byte output. After the last memory address, the address counter 'rolls-over', and the device continues to output data from memory address 00h.

Acknowledge in Read Mode

For all Read commands, the device waits, after each byte read, for an acknowledgment during the 9th bit time. If the bus master does not drive Serial Data (SDA) Low during this time, the device terminates the data transfer and switches to its Stand-by mode.

USE WITHIN A DRAM DIMM

In the application, the M34C02 is soldered directly in the printed circuit module. The 3 Chip Enable inputs (pins 1, 2 and 3) are wired at V_{CC} or V_{SS} through the DIMM socket (see [Table 5](#)). The pull-up resistors needed for normal behavior of the I²C bus are connected on the I²C bus of the motherboard (as shown in [Figure 12](#)).

The Write Control (\overline{WC}) of the M34C02 can be left unconnected. However, connecting it to V_{SS} is recommended, to maintain full read and write access.

Programming the M34C02

When the M34C02 is delivered, full read and write access is given to the whole memory array. It is

recommended that the first step is to use the test equipment to write the module information (such as its access speed, its size, its organization) to the first half of the memory, starting from the first memory location. When the data has been validated, the test equipment can send a Write command to the Protection Register, using the device select code '01100000b' followed by an address and data byte (made up of Don't Care values) as shown in [Figure 7](#). The first 128 bytes of the memory area are then write-protected, and the M34C02 will no longer respond to the specific device select code '0110000xb'. It is not possible to reverse this sequence.

Table 5. DRAM DIMM Connections

DIMM Position	E2	E1	E0
0	V_{SS}	V_{SS}	V_{SS}
1	V_{SS}	V_{SS}	V_{CC}
2	V_{SS}	V_{CC}	V_{SS}
3	V_{SS}	V_{CC}	V_{CC}
4	V_{CC}	V_{SS}	V_{SS}
5	V_{CC}	V_{SS}	V_{CC}
6	V_{CC}	V_{CC}	V_{SS}
7	V_{CC}	V_{CC}	V_{CC}

INITIAL DELIVERY STATE

The device is delivered with the memory array erased: all bits are set to 1 (each byte contains FFh).

M34C02

Figure 12. Serial Presence Detect Block Diagram

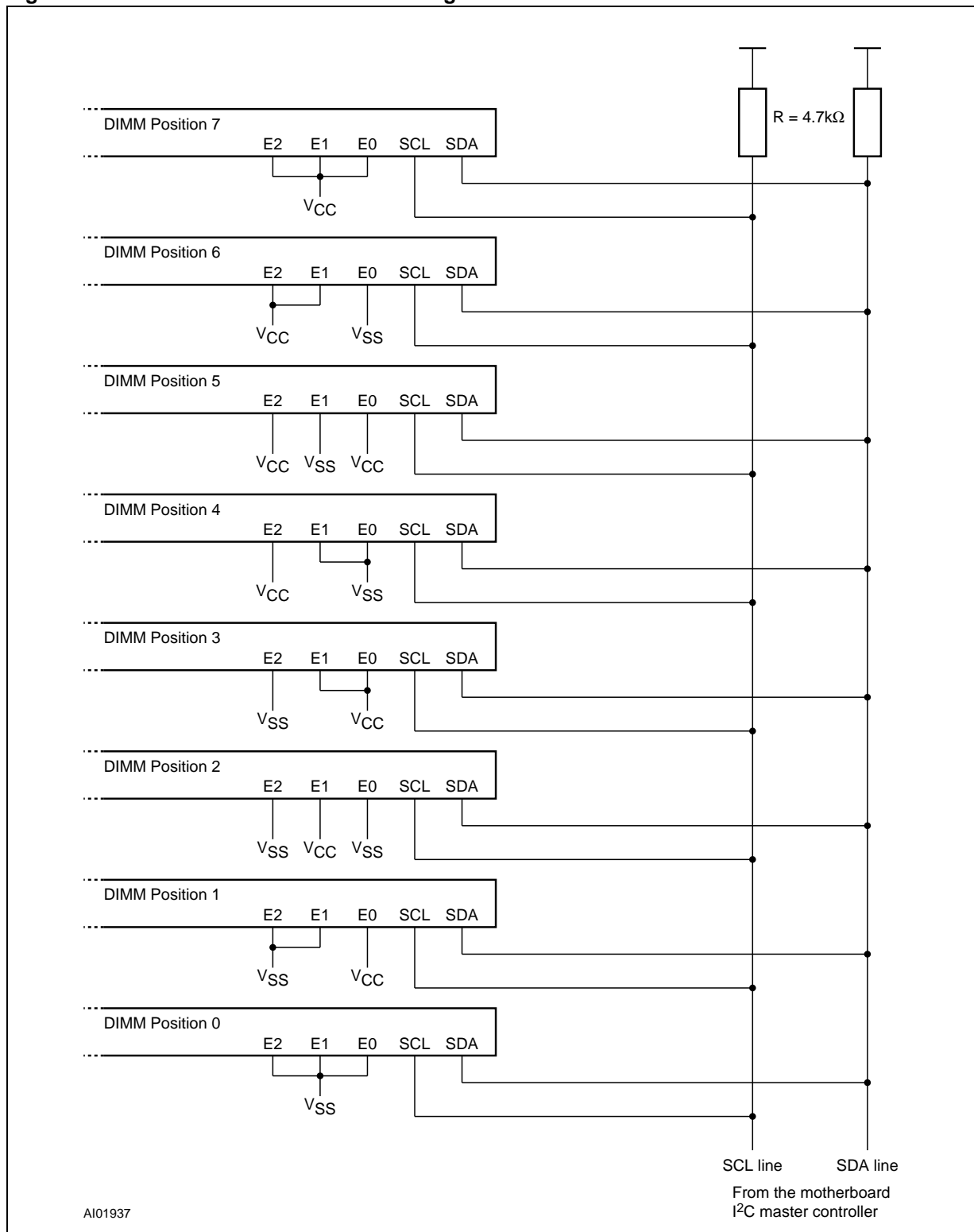

- Note:
1. E0, E1 and E2 are wired at each DIMM socket in a binary sequence for a maximum of 8 devices.
 2. Common clock and common data are shared across all the devices.
 3. Pull-up resistors are required on all SDA and SCL bus lines (typically 4.7 kΩ) because these lines are open drain when used as outputs.

MAXIMUM RATING

Stressing the device above the rating listed in the "Absolute Maximum Ratings" table may cause permanent damage to the device. These are stress ratings only and operation of the device at these or any other conditions above those indicated in the Operating sections of this specification is not im-

plied. Exposure to Absolute Maximum Rating conditions for extended periods may affect device reliability. Refer also to the STMicroelectronics SURE Program and other relevant quality documents.

Table 6. Absolute Maximum Ratings

Symbol	Parameter	Min.	Max.	Unit
T _A	Ambient Operating Temperature	-40	90	°C
T _{STG}	Storage Temperature	-65	150	°C
T _{LEAD}	Lead Temperature during Soldering ¹	See Note: 1.		°C
V _{IO}	Input or Output Voltage	-0.50	6.5	V
V _{CC}	Supply Voltage	-0.50	6.5	V
V _{ESD}	Electrostatic Discharge Voltage (Human Body model) ²	-4000	4000	V

Note: 1. Compliant with JEDEC Std J-STD-020C (for small body, Sn-Pb or Pb assembly), the ST ECOPACK[®] 7191395 specification, and the European directive on Restrictions on Hazardous Substances (RoHS) 2002/95/EU.

2. JEDEC Std JESD22-A114A (C1=100 pF, R1=1500 Ω, R2=500 Ω)

M34C02**DC AND AC PARAMETERS**

This section summarizes the operating and measurement conditions, and the DC and AC characteristics of the device. The parameters in the DC and AC Characteristic tables that follow are derived from tests performed under the Measure-

ment Conditions summarized in the relevant tables. Designers should check that the operating conditions in their circuit match the measurement conditions when relying on the quoted parameters.

Table 7. Operating Conditions (M34C02-W)

Symbol	Parameter	Min.	Max.	Unit
V _{CC}	Supply Voltage	2.5	5.5	V
T _A	Ambient Operating Temperature	-40	85	°C

Table 8. Operating Conditions (M34C02-L)

Symbol	Parameter	Min.	Max.	Unit
V _{CC}	Supply Voltage	2.2	5.5	V
T _A	Ambient Operating Temperature	-40	85	°C

Table 9. Operating Conditions (M34C02-R)

Symbol	Parameter	Min.	Max.	Unit
V _{CC}	Supply Voltage	1.8	5.5	V
T _A	Ambient Operating Temperature	-40	85	°C

Table 10. Operating Conditions (M34C02-F)

Symbol	Parameter	Min.	Max.	Unit
V _{CC}	Supply Voltage	1.7	3.6	V
T _A	Ambient Operating Temperature	0	70	°C

Table 11. AC Measurement Conditions

Symbol	Parameter	Min.	Max.	Unit
C_L	Load Capacitance	100		pF
	Input Rise and Fall Times		50	ns
	Input Levels	0.2V _{CC} to 0.8V _{CC}		V
	Input and Output Timing Reference Levels	0.3V _{CC} to 0.7V _{CC}		V

Figure 13. AC Measurement I/O Waveform

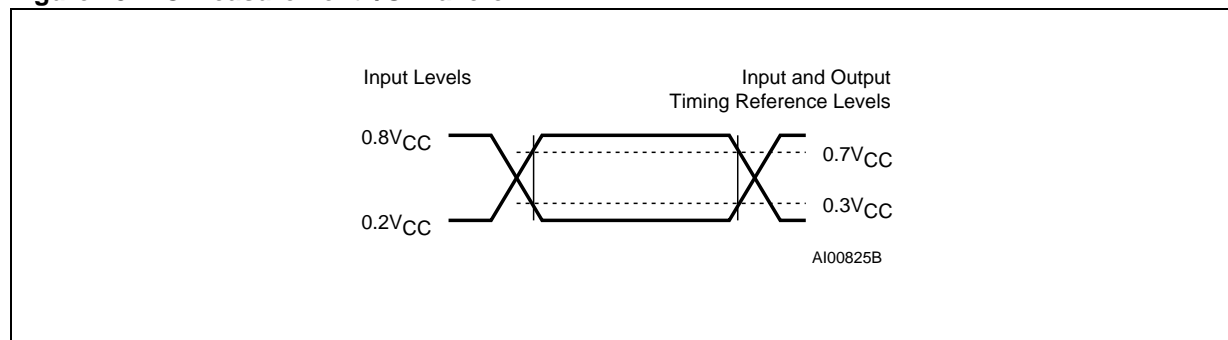

Table 12. Input Parameters

Symbol	Parameter ^{1,2}	Test Condition	Min.	Max.	Unit
C_{IN}	Input Capacitance (SDA)			8	pF
C_{IN}	Input Capacitance (other pins)			6	pF
Z_{WCL}	\overline{WC} Input Impedance	$V_{IN} < 0.3 V$	15	70	k Ω
Z_{WCH}	\overline{WC} Input Impedance	$V_{IN} > 0.7V_{CC}$	500		k Ω
t_{NS}	Pulse width ignored (Input Filter on SCL and SDA)	Single glitch		100	ns

Note: 1. $T_A = 25^\circ C$, $f = 400kHz$
 2. Sampled only, not 100% tested.

M34C02**Table 13. DC Characteristics (M34C02-W)**

Symbol	Parameter	Test Condition (in addition to those in Table 7.)	Min.	Max.	Unit
I_{LI}	Input Leakage Current (SCL, SDA, E0, E1, and E2)	$V_{IN} = V_{SS}$ or V_{CC}		± 2	μA
I_{LO}	Output Leakage Current	$V_{OUT} = V_{SS}$ or V_{CC} , SDA in Hi-Z		± 2	μA
I_{CC}	Supply Current	$V_{CC}=5V$, $f_c=400kHz$ (rise/fall time < 30ns)		2	mA
		$V_{CC}=2.5V$, $f_c=400kHz$ (rise/fall time < 30ns)		1	mA
I_{CC1}	Stand-by Supply Current	$V_{IN} = V_{SS}$ or V_{CC} , $V_{CC} = 5 V$		1	μA
		$V_{IN} = V_{SS}$ or V_{CC} , $V_{CC} = 2.5 V$		0.5	μA
V_{IL}	Input Low Voltage ⁽¹⁾		-0.45	$0.3V_{CC}$	V
V_{IH}	Input High Voltage ⁽¹⁾		$0.7V_{CC}$	$V_{CC}+1$	V
V_{OL}	Output Low Voltage	$I_{OL} = 2.1 mA$, $V_{CC} = 2.5 V$		0.4	V

Note: 1. The voltage source driving only E0, E1 and E2 inputs must provide an impedance of less than 1kOhm.

Table 14. DC Characteristics (M34C02-L)

Symbol	Parameter	Test Condition (in addition to those in Table 8.)	Min.	Max.	Unit
I_{LI}	Input Leakage Current (SCL, SDA)	$V_{IN} = V_{SS}$ or V_{CC}		± 2	μA
I_{LO}	Output Leakage Current	$V_{OUT} = V_{SS}$ or V_{CC} , SDA in Hi-Z		± 2	μA
I_{CC}	Supply Current	$V_{CC}=5V$, $f_c=400kHz$ (rise/fall time < 30ns)		2	mA
		$V_{CC}=2.5V$, $f_c=400kHz$ (rise/fall time < 30ns)		1	mA
		$V_{CC}=2.2V$, $f_c=400kHz$ (rise/fall time < 30ns)		1	mA
I_{CC1}	Stand-by Supply Current	$V_{IN} = V_{SS}$ or V_{CC} , $V_{CC} = 5 V$		1	μA
		$V_{IN} = V_{SS}$ or V_{CC} , $2.2V \leq V_{CC} < 2.5V$		0.5	μA
V_{IL}	Input Low Voltage (E2, E1, E0, SCL, SDA)		-0.3	$0.3V_{CC}$	V
	Input Low Voltage (\overline{WC})		-0.3	0.5	V
V_{IH}	Input High Voltage (E2, E1, E0, SCL, SDA, \overline{WC})		$0.7V_{CC}$	$V_{CC}+1$	V
V_{OL}	Output Low Voltage	$I_{OL} = 3mA$, $V_{CC} = 5V$		0.4	V
		$I_{OL} = 2.1mA$, $2.2V \leq V_{CC} < 2.5V$		0.4	V

Table 15. DC Characteristics (M34C02-R)

Symbol	Parameter	Test Condition (in addition to those in Table 9.)	Min.	Max.	Unit
I_{LI}	Input Leakage Current (SCL, SDA, E0, E1 and E2)	$V_{IN} = V_{SS} \text{ or } V_{CC}$		± 2	μA
I_{LO}	Output Leakage Current	$V_{OUT} = V_{SS} \text{ or } V_{CC}$, SDA in Hi-Z		± 2	μA
I_{CC}	Supply Current	$V_{CC} = 5\text{V}$, $f_c = 400\text{kHz}$ (rise/fall time < 30ns)		2	mA
		$V_{CC} = 2.5\text{V}$, $f_c = 400\text{kHz}$ (rise/fall time < 30ns)		1	mA
		$V_{CC} = 1.8\text{V}$, $f_c = 400\text{kHz}$ (rise/fall time < 30ns)		1	mA
I_{CC1}	Stand-by Supply Current	$V_{IN} = V_{SS} \text{ or } V_{CC}$, $V_{CC} = 5\text{V}$		1	μA
		$V_{IN} = V_{SS} \text{ or } V_{CC}$, $1.8\text{V} \leq V_{CC} < 2.5\text{V}$		0.5	μA
V_{IL}	Input Low Voltage ⁽¹⁾	$2.5\text{V} \leq V_{CC} \leq 5.5\text{V}$	-0.3	$0.3 V_{CC}$	V
		$1.8\text{V} \leq V_{CC} < 2.5\text{V}$	-0.3	$0.25 V_{CC}$	V
V_{IH}	Input High Voltage ⁽¹⁾		$0.7V_{CC}$	$V_{CC}+1$	V
V_{OL}	Output Low Voltage	$I_{OL} = 3\text{mA}$, $V_{CC} = 5\text{V}$		0.4	V
		$I_{OL} = 2.1\text{mA}$, $2.2\text{V} \leq V_{CC} < 2.5\text{V}$		0.4	V
		$I_{OL} = 0.15\text{mA}$, $V_{CC} = 1.8\text{V}$		0.2	V

Note: 1. The voltage source driving only E0, E1 and E2 inputs must provide an impedance of less than 1kOhm.

Table 16. DC Characteristics (M34C02-F)

Symbol	Parameter	Test Condition (in addition to those in Table 10.)	Min. ¹	Max. ¹	Unit
I_{LI}	Input Leakage Current (SCL, SDA, E0, E1 and E2)	$V_{IN} = V_{SS} \text{ or } V_{CC}$		± 2	μA
I_{LO}	Output Leakage Current	$V_{OUT} = V_{SS} \text{ or } V_{CC}$, SDA in Hi-Z		± 2	μA
I_{CC}	Supply Current	$V_{CC} = 1.7\text{V}$, $f_c = 100\text{kHz}$ (rise/fall time < 30ns)		1	mA
I_{CC1}	Stand-by Supply Current	$V_{IN} = V_{SS} \text{ or } V_{CC}$, $V_{CC} = 3.6\text{V}$		1	μA
		$V_{IN} = V_{SS} \text{ or } V_{CC}$, $1.7\text{V} \leq V_{CC} < 2.5\text{V}$		0.5	μA
V_{IL}	Input Low Voltage ⁽²⁾	$2.5\text{V} \leq V_{CC} \leq 3.6\text{V}$	-0.3	$0.3 V_{CC}$	V
		$1.7\text{V} \leq V_{CC} < 2.5\text{V}$	-0.3	$0.25 V_{CC}$	V
V_{IH}	Input High Voltage ⁽²⁾		$0.7V_{CC}$	$V_{CC}+1$	V
V_{OL}	Output Low Voltage	$I_{OL} = 2.1\text{mA}$, $2.2\text{V} \leq V_{CC} \leq 3.6\text{V}$		0.4	V
		$I_{OL} = 0.15\text{mA}$, $V_{CC} = 1.7\text{V}$		0.2	V

Note: 1. Preliminary Data.

2. The voltage source driving only E0, E1 and E2 inputs must provide an impedance of less than 1kOhm.

M34C02**Table 17. AC Characteristics (M34C02-W, M34C02-L, M34C02-R)**

Test conditions specified in Table 11. and Table 7. or Table 8.					
Symbol	Alt.	Parameter	Min.	Max.	Unit
f_c	f_{SCL}	Clock Frequency		400	kHz
t_{CHCL}	t_{HIGH}	Clock Pulse Width High	600		ns
t_{CLCH}	t_{LOW}	Clock Pulse Width Low	1300		ns
t_{DL1DL2}^2	t_F	SDA Fall Time	20	300	ns
t_{DXCX}	$t_{SU:DAT}$	Data In Set Up Time	100		ns
t_{CLDX}	$t_{HD:DAT}$	Data In Hold Time	0		ns
t_{CLQX}	t_{DH}	Data Out Hold Time	200		ns
t_{CLQV}^3	t_{AA}	Clock Low to Next Data Valid (Access Time)	200	900	ns
t_{CHDX}^1	$t_{SU:STA}$	Start Condition Set Up Time	600		ns
t_{DLCL}	$t_{HD:STA}$	Start Condition Hold Time	600		ns
t_{CHDH}	$t_{SU:STO}$	Stop Condition Set Up Time	600		ns
t_{DHDL}	t_{BUF}	Time between Stop Condition and Next Start Condition	1300		ns
t_W	t_{WR}	Write Time		10	ms

Note: 1. For a reSTART condition, or following a Write cycle.

2. Sampled only, not 100% tested.

3. To avoid spurious START and STOP conditions, a minimum delay is placed between SCL=1 and the falling or rising edge of SDA.

Table 18. AC Characteristics (M34C02-F)

Test conditions specified in Table 11. and Table 9. or Table 10.					
Symbol	Alt.	Parameter	Min.	Max.	Unit
f_c	f_{SCL}	Clock Frequency		100	kHz
t_{CHCL}	t_{HIGH}	Clock Pulse Width High	4000		ns
t_{CLCH}	t_{LOW}	Clock Pulse Width Low	4700		ns
t_{DL1DL2}^2	t_F	SDA Fall Time	20	300	ns
t_{DXCX}	$t_{SU:DAT}$	Data In Set Up Time	250		ns
t_{CLDX}	$t_{HD:DAT}$	Data In Hold Time	0		ns
t_{CLQX}	t_{DH}	Data Out Hold Time	200		ns
t_{CLQV}^3	t_{AA}	Clock Low to Next Data Valid (Access Time)	200	3500	ns
t_{CHDX}^1	$t_{SU:STA}$	Start Condition Set Up Time	4700		ns
t_{DLCL}	$t_{HD:STA}$	Start Condition Hold Time	4000		ns
t_{CHDH}	$t_{SU:STO}$	Stop Condition Set Up Time	4000		ns
t_{DHDL}	t_{BUF}	Time between Stop Condition and Next Start Condition	4700		ns
t_W	t_{WR}	Write Time		10	ms

Note: 1. For a reSTART condition, or following a Write cycle.

2. Sampled only, not 100% tested.

3. To avoid spurious START and STOP conditions, a minimum delay is placed between SCL=1 and the falling or rising edge of SDA.

Figure 14. AC Waveforms

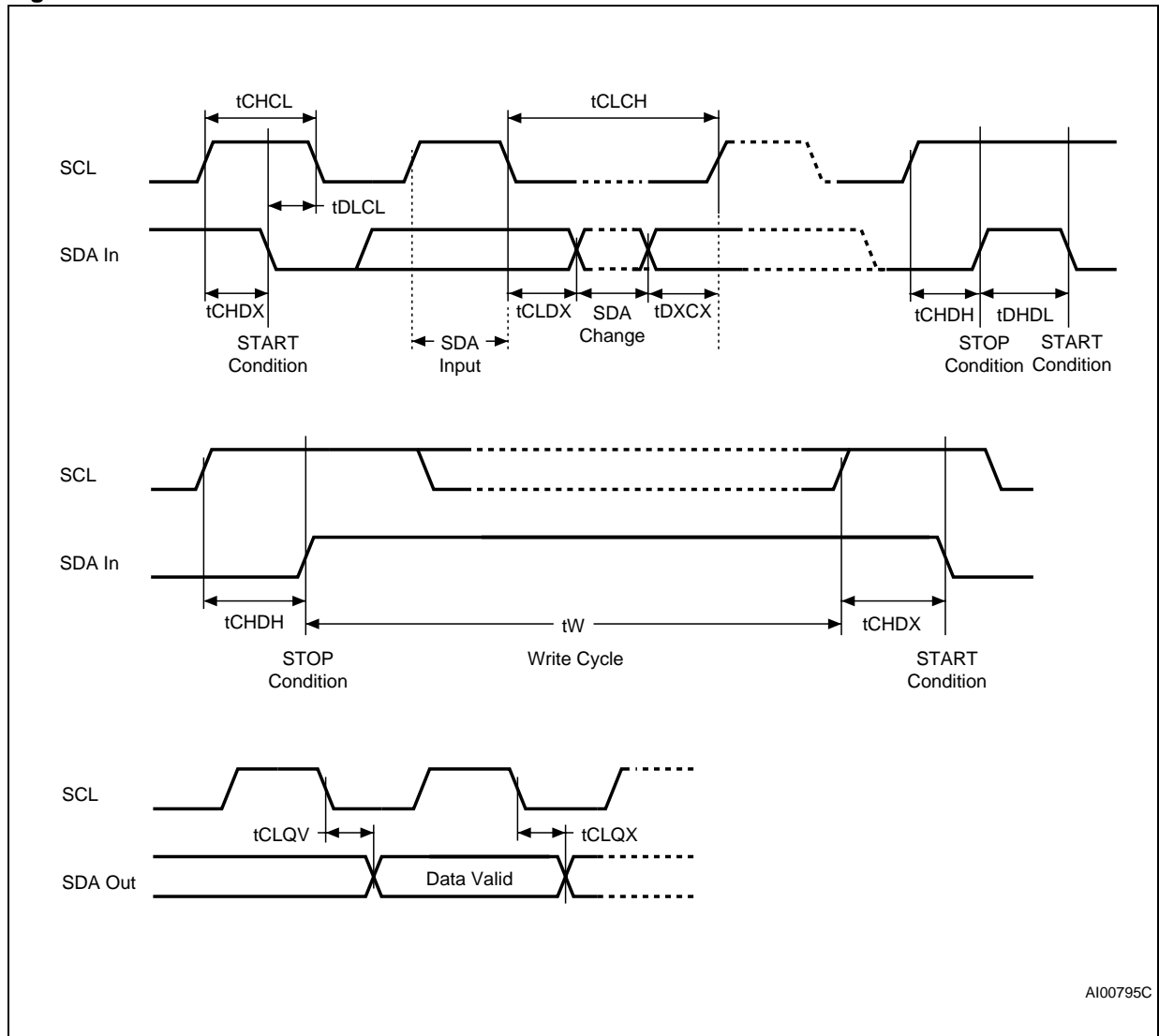

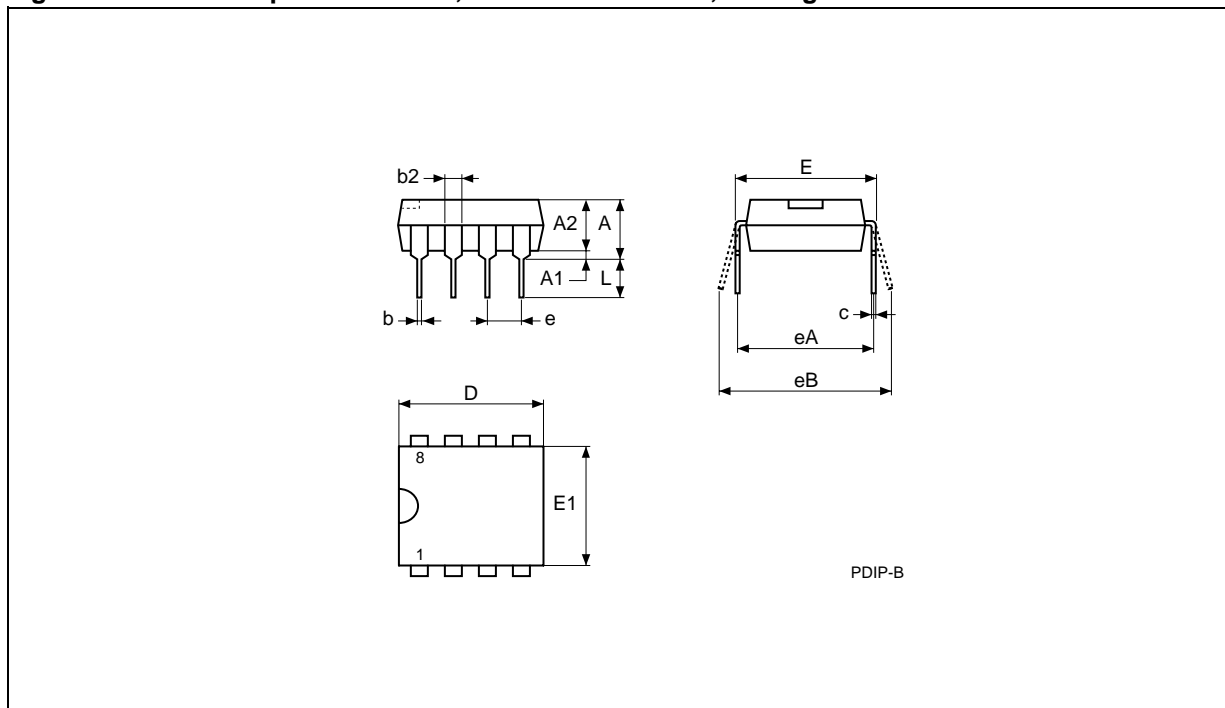
M34C02**PACKAGE MECHANICAL****Figure 15. PDIP8 – 8 pin Plastic DIP, 0.25mm lead frame, Package Outline**

Note: Drawing is not to scale.

Table 19. PDIP8 – 8 pin Plastic DIP, 0.25mm lead frame, Package Mechanical Data

Symb.	mm			inches		
	Typ.	Min.	Max.	Typ.	Min.	Max.
A			5.33			0.210
A1		0.38			0.015	
A2	3.30	2.92	4.95	0.130	0.115	0.195
b	0.46	0.36	0.56	0.018	0.014	0.022
b2	1.52	1.14	1.78	0.060	0.045	0.070
c	0.25	0.20	0.36	0.010	0.008	0.014
D	9.27	9.02	10.16	0.365	0.355	0.400
E	7.87	7.62	8.26	0.310	0.300	0.325
E1	6.35	6.10	7.11	0.250	0.240	0.280
e	2.54	–	–	0.100	–	–
eA	7.62	–	–	0.300	–	–
eB			10.92			0.430
L	3.30	2.92	3.81	0.130	0.115	0.150

Figure 16. UFDFPN8 (MLP8) 8-lead Ultra thin Fine pitch Dual Flat Package No lead 2x3mm², Package Outline

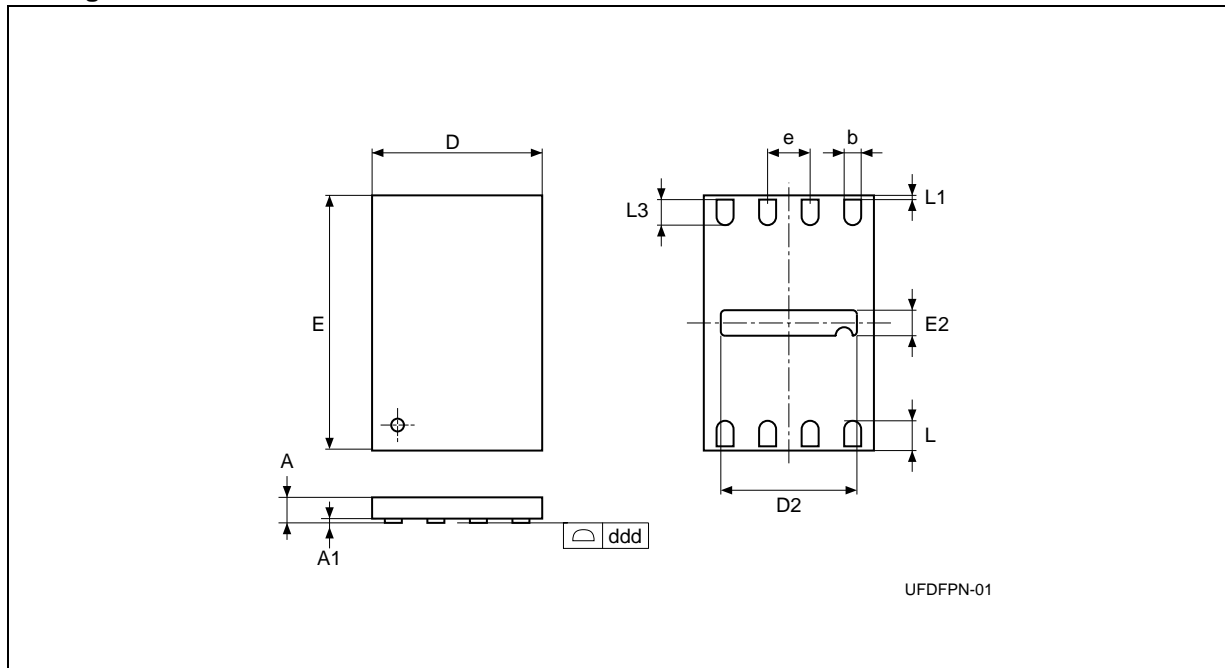

Note: 1. Drawing is not to scale.

2. The central pad (the area E2 by D2 in the above illustration) is pulled, internally, to V_{SS}. It must not be allowed to be connected to any other voltage or signal line on the PCB, for example during the soldering process.

Table 20. UFDFPN8 (MLP8) 8-lead Ultra thin Fine pitch Dual Flat Package No lead 2x3mm², Package Mechanical Data

Symbol	mm			inches		
	Typ.	Min.	Max.	Typ.	Min.	Max.
A	0.55	0.50	0.60	0.022	0.020	0.024
A1		0.00	0.05		0.000	0.002
b	0.25	0.20	0.30	0.010	0.008	0.012
D	2.00			0.079		
D2		1.55	1.65		0.061	0.065
ddd			0.05			0.002
E	3.00			0.118		
E2		0.15	0.25		0.006	0.010
e	0.50	–	–	0.020	–	–
L	0.45	0.40	0.50	0.018	0.016	0.020
L1			0.15			0.006
L3		0.30			0.012	
N	8			8		

M34C02

Figure 17. TSSOP8 – 8 lead Thin Shrink Small Outline, Package Outline

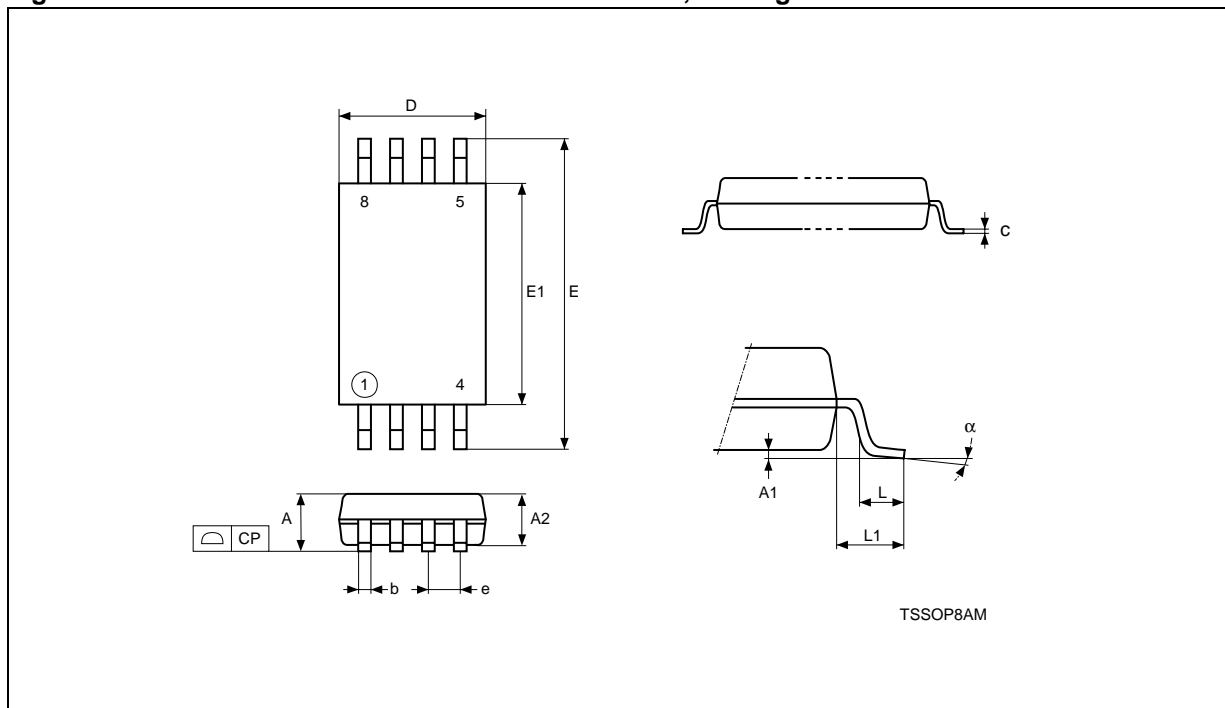

Note: Drawing is not to scale.

Table 21. TSSOP8 – 8 lead Thin Shrink Small Outline, Package Mechanical Data

Symbol	mm			inches		
	Typ.	Min.	Max.	Typ.	Min.	Max.
A			1.200			0.0472
A1		0.050	0.150		0.0020	0.0059
A2	1.000	0.800	1.050	0.0394	0.0315	0.0413
b		0.190	0.300		0.0075	0.0118
c		0.090	0.200		0.0035	0.0079
CP			0.100			0.0039
D	3.000	2.900	3.100	0.1181	0.1142	0.1220
e	0.650	–	–	0.0256	–	–
E	6.400	6.200	6.600	0.2520	0.2441	0.2598
E1	4.400	4.300	4.500	0.1732	0.1693	0.1772
L	0.600	0.450	0.750	0.0236	0.0177	0.0295
L1	1.000			0.0394		
α		0°	8°		0°	8°

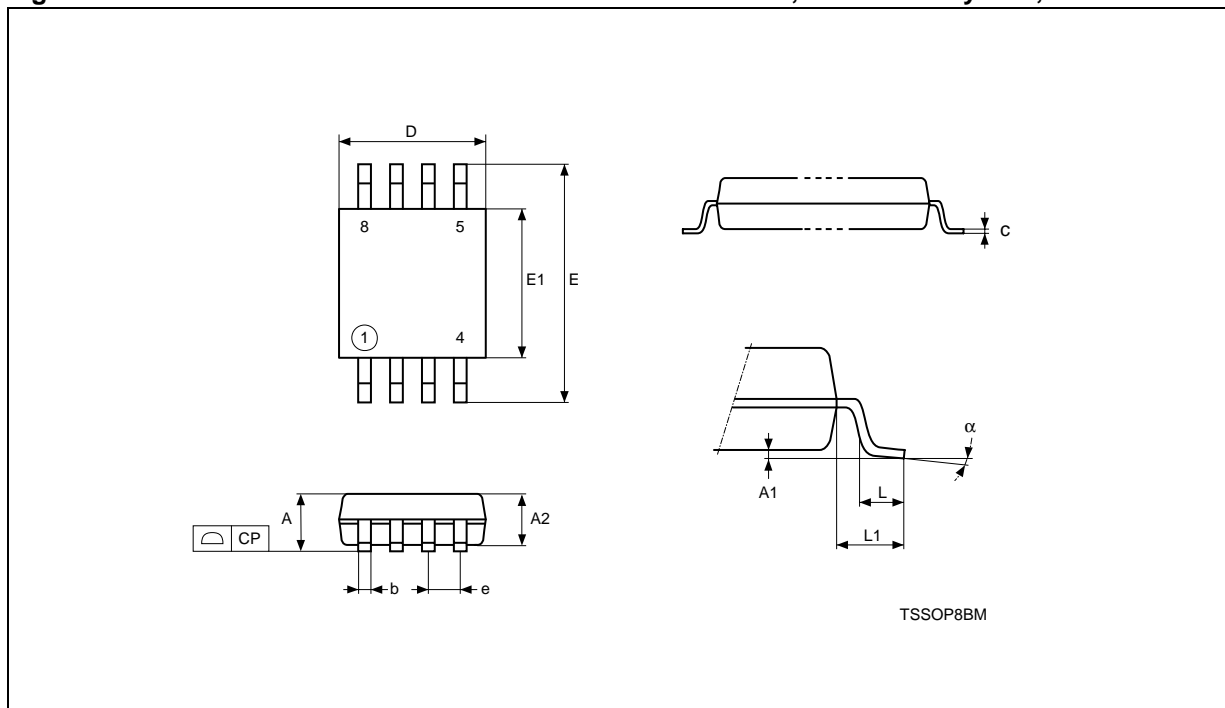
Figure 18. TSSOP8 3x3mm² – 8 lead Thin Shrink Small Outline, 3x3mm² body size, Outline

Note: Drawing is not to scale.

Table 22. TSSOP8 3x3mm² – 8 lead Thin Shrink Small Outline, 3x3mm² body size, Data

Symbol	mm			inches		
	Typ.	Min.	Max.	Typ.	Min.	Max.
A			1.100			0.0433
A1		0.050	0.150		0.0020	0.0059
A2	0.850	0.750	0.950	0.0335	0.0295	0.0374
b		0.250	0.400		0.0098	0.0157
c		0.130	0.230		0.0051	0.0091
D	3.000	2.900	3.100	0.1181	0.1142	0.1220
E	4.900	4.650	5.150	0.1929	0.1831	0.2028
E1	3.000	2.900	3.100	0.1181	0.1142	0.1220
e	0.650	–	–	0.0256	–	–
CP			0.100			0.0039
L	0.550	0.400	0.700	0.0217	0.0157	0.0276
L1	0.950			0.0374		
α		0°	6°		0°	6°

M34C02**PART NUMBERING****Table 23. Ordering Information Scheme**

Example:	M34C02	-	W	MB	6	T	P
Device Type M34 = ASSP I ² C serial access EEPROM							
Device Function 02 = 2 Kbit (256 x 8)							
Operating Voltage W = V _{CC} = 2.5 to 5.5V (400kHz) L = V _{CC} = 2.2 to 5.5V (400kHz) R = V _{CC} = 1.8 to 5.5V (400kHz) F = V _{CC} = 1.7 to 3.6V (100kHz)							
Package BN ¹ = PDIP8 MB = UDFDFPN8 (MLP8) DW = TSSOP8 (169 mil width) DS = TSSOP8 (3x3mm ² body size, MSOP8)							
Device Grade 6 = Industrial temperature range, -40 to 85 °C. Device tested with standard test flow 1 = Temperature range 0 to 70 °C. Device tested with standard test flow							
Option blank = Standard Packing T = Tape and Reel Packing							
Plating Technology blank = Standard SnPb plating P or G = ECOPACK® (RoHS compliant)							

Note: 1. Package available only on request.

For a list of available options (speed, package, etc.) or for further information on any aspect of this device, please contact your nearest ST Sales Office.

The category of second Level Interconnect is marked on the package and on the inner box label, in compliance with JEDEC Standard JESD97. The maximum ratings related to soldering conditions are also marked on the inner box label.

REVISION HISTORY

Table 24. Revision History

Date	Rev.	Description of Revision
27-Dec-1999	2.0	Adjustments to the formatting. 0 to 70°C temperature range removed from DC and AC tables. No change to description of device, or parameters
07-Dec-2000	2.1	New definition of lead soldering temperature absolute rating for certain packages
13-Mar-2001	2.2	-R voltage range added
18-Jul-2002	2.3	TSSOP8 (3x3mm ² body size) package (MSOP8) added
22-May-2002	2.4	VDFPN8 package (MLP8) added
21-Jul-2003	3.0	Document reformatted. -F voltage range added.
17-Mar-2004	4.0	Table of Contents added. MLP package changed. Absolute Maximum Ratings for $V_{IO}(\min)$ and $V_{CC}(\min)$ changed. Soldering temperature information clarified for RoHS compliant devices. Device grade information clarified
14-Apr-2004	5.0	Typos corrected in Ordering Information example
26-Aug-2004	6.0	Device Grade clarified. Product List summary table added
30-Nov-2004	7.0	SO8 package removed.
14-Oct-2005	8.0	M34C02-R operating frequency upgraded to 400 kHz. Modified Device Internal Reset, page 5, Figure 5. , Maximum RP Value versus Bus Parasitic Capacitance (C) for an I²C Bus, Table 12. , Input Parameters, I_{CC1} values in Table 13. , DC Characteristics (M34C02-W), Table 15. , DC Characteristics (M34C02-R), Table 16. , DC Characteristics (M34C02-F) and moved M34C02-R to Table 17. , AC Characteristics (M34C02-W, M34C02-L, M34C02-R) . Added Figure 4. , Chip Enable input connection . Added EcoPack® and Ambient Operating Temperature information.

M34C02

Information furnished is believed to be accurate and reliable. However, STMicroelectronics assumes no responsibility for the consequences of use of such information nor for any infringement of patents or other rights of third parties which may result from its use. No license is granted by implication or otherwise under any patent or patent rights of STMicroelectronics. Specifications mentioned in this publication are subject to change without notice. This publication supersedes and replaces all information previously supplied. STMicroelectronics products are not authorized for use as critical components in life support devices or systems without express written approval of STMicroelectronics.

The ST logo is a registered trademark of STMicroelectronics.
ECOPACK is a registered trademark of STMicroelectronics.
All other names are the property of their respective owners

© 2005 STMicroelectronics - All rights reserved

STMicroelectronics group of companies
Australia - Belgium - Brazil - Canada - China - Czech Republic - Finland - France - Germany - Hong Kong - India - Israel - Italy - Japan -
Malaysia - Malta - Morocco - Singapore - Spain - Sweden - Switzerland - United Kingdom - United States of America
www.st.com

OUR CERTIFICATE

DiGi provide top-quality products and perfect service for customer worldwide through standardization, technological innovation and continuous improvement. DiGi through third-party certification, we stricly control the quality of products and services. Welcome your RFQ to

Email: Info@DiGi-Electronics.com



Tel: +00 852-30501935

RFQ Email: Info@DiGi-Electronics.com

DiGi is a global authorized distributor of electronic components.