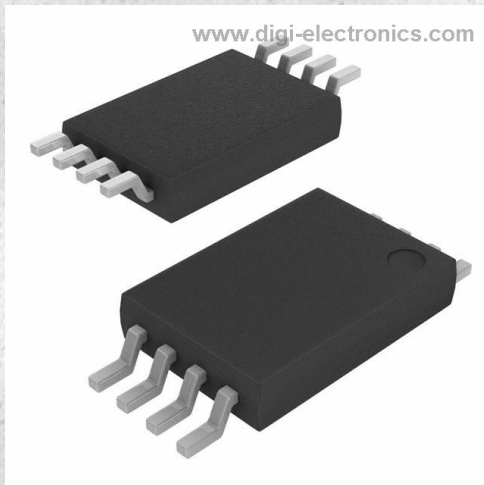


M95040-DRDW3TP/K Datasheet



<https://www.DiGi-Electronics.com>

DiGi Electronics Part Number	M95040-DRDW3TP/K-DG
Manufacturer	STMicroelectronics
Manufacturer Product Number	M95040-DRDW3TP/K
Description	IC EEPROM 4KBIT SPI 20MHZ 8TSSOP
Detailed Description	EEPROM Memory IC 4Kbit SPI 20 MHz 8-TSSOP

This model M95040-DRDW3TP/K is available at DiGi Electronics.

DiGi Electronics offers a global database of semiconductor and electronic component datasheets.

We welcome your inquiries regarding pricing, lead time, or other product-related questions.

 [Request a Quote](#)

 [Datasheet Search](#)



Tel: +00 852-30501935

RFQ Email: Info@DiGi-Electronics.com

DiGi is a global authorized distributor of electronic components.

Purchase and inquiry

Manufacturer Product Number:

M95040-DRDW3TP/K

Series:

-

DiGi-Electronics Programmable:

Not Verified

Memory Format:

EEPROM

Memory Size:

4Kbit

Memory Interface:

SPI

Write Cycle Time - Word, Page:

4ms

Operating Temperature:

-40°C ~ 125°C (TA)

Qualification:

AEC-Q100

Package / Case:

8-TSSOP (0.173", 4.40mm Width)

Base Product Number:

M95040

Manufacturer:

STMicroelectronics

Product Status:

Active

Memory Type:

Non-Volatile

Technology:

EEPROM

Memory Organization:

512 x 8

Clock Frequency:

20 MHz

Voltage - Supply:

1.8V ~ 5.5V

Grade:

Automotive

Mounting Type:

Surface Mount

Supplier Device Package:

8-TSSOP

Environmental & Export classification

RoHS Status:

ROHS3 Compliant

REACH Status:

REACH Unaffected

HTSUS:

8542.32.0051

Moisture Sensitivity Level (MSL):

1 (Unlimited)

ECCN:

EAR99



Automotive 4-Kbit serial SPI bus EEPROM with high-speed clock



SO8N
(150 mil width)



TSSOP8
(169 mil width)



WFDFPN8 - DFN8
(2 x 3 mm)

Features

Grade

- AEC-Q100 grade 0 qualification



SPI interface

- Compatible with the serial peripheral interface (SPI) bus

Memory

- 4-Kbit (512-byte) of EEPROM
- Page size: 16-byte
- Write protection by block: 1/4, 1/2, or whole memory
- Additional write-lockable page (identification page)

Supply voltage

- 1.7 to 5.5 V up to 125 °C and 2.5 to 5.5 V up to 145 °C

Temperature

- -40 °C to +125 °C for range 3 and -40 °C to +145 °C for range 4

High-speed clock frequency

- 20 MHz for $V_{CC} \geq 4.5$ V
- 10 MHz for $V_{CC} \geq 2.5$ V
- 5 MHz for $V_{CC} \geq 1.7$ V

Write cycle time

- Byte and page write within 4 ms

Write cycle endurance

- 4 million write cycles at 25 °C
- 1.2 million write cycles at 85 °C
- 600 k write cycles at 125 °C
- 400 k write cycles at 145 °C

Advanced features

- Schmitt trigger inputs for noise filtering
- ESD human body model 4000 V

Data retention

- 100 years at 25 °C and 50 years at 125 °C

Packages

- SO8N, TSSOP8, and WFDFPN8 (ECOPACK2-compliant)

Product status

M95040-A125

M95040-A145

Product label



1 Description

The M95040-A125 and M95040-A145 are 4-Kbit serial EEPROM (electrically erasable programmable memory) automotive-grade devices capable of operating up to 145 °C. They comply with the high reliability automotive standard AEC-Q100 grade 0, and are accessed through a simple serial SPI-compatible interface running at up to 20 MHz.

The devices are byte-alterable memories (512 × 8 bits), organized as 32 pages of 16 bytes, in which the data integrity is significantly improved thanks to an embedded error correction code logic.

The M95040-A125 and M95040-A145 offer an additional identification page (16 bytes), where the ST device identification can be read. This page can also store sensitive application parameters, which can later be permanently locked in read-only mode.

Figure 1. Logic diagram

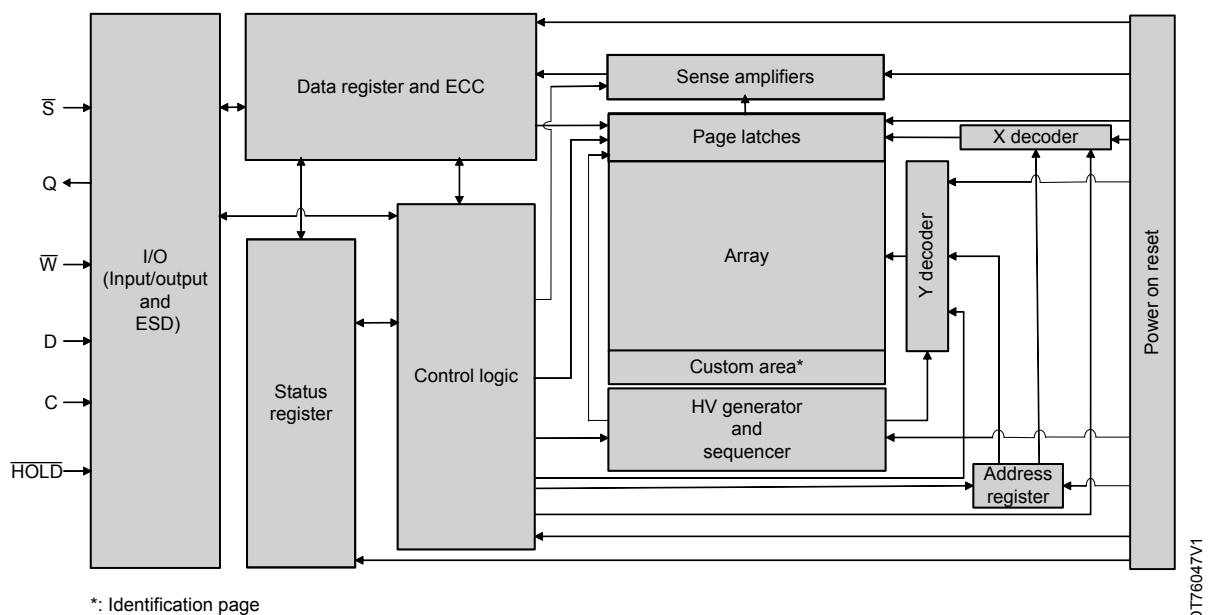
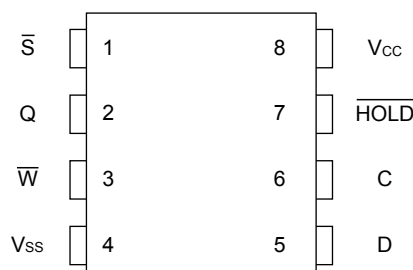


Figure 2. 8-pin package connections



1. See Section 9: Package information for package dimensions and how to identify pin 1.



Table 1. Signal names

Signal name	Description
C	Serial clock
D	Serial data input
Q	Serial data output
\bar{S}	Chip select
\bar{W}	Write protect
HOLD	Hold
V _{CC}	Supply voltage
V _{SS}	Ground



2 Signal description

All input signals must be held high or low (according to voltages of V_{IH} or V_{IL} , as specified in Table 11 and Table 12). These signals are described in the following subsections.

2.1 Serial data output (Q)

This output signal is used to transfer data serially out of the device during a read operation. Data are shifted out on the falling edge of the serial clock (C), the most significant bit (MSB) first. In all other cases, the serial data output is in high impedance.

2.2 Serial data input (D)

This input signal is used to transfer data serially into the device. D input receives instructions, addresses, and the data to be written. Values are latched on the rising edge of the serial clock (C), the most significant bit (MSB) first.

2.3 Serial clock (C)

This input signal provides the timing of the serial interface. Instructions, addresses, or data present at serial data input (D) are latched on the rising edge of the serial clock (C). Data on serial data output (Q) change after the falling edge.

2.4 Chip select (\overline{S})

Driving chip select (\overline{S}) low enables the device to start communication. Driving chip select high deselects the device and serial data output enters the high impedance state.

2.5 Hold condition (\overline{HOLD})

The \overline{HOLD} signal is used to pause any serial communications with the device without resetting the clocking sequence.

To enter the hold condition, the device must be selected, with chip select (\overline{S}) low. During this condition, the serial data output (Q) is in high-Z, and the serial data input (D) and the serial clock (C) are don't care.

2.6 Write protect (\overline{W})

This pin is used to write-protect the status register.

2.7 V_{SS} ground

V_{SS} is the reference for all signals, including the V_{CC} .

2.8 V_{CC} supply voltage

V_{CC} is the supply voltage pin.



3 Operating features

3.1 Active power and standby power modes

When chip select is low, the device is selected and in the active power mode. When it is high, the device is deselected. If a write cycle is not in progress, the device goes in standby power mode, and its consumption drops to I_{CC1} , as specified in Table 11 and Table 12.

3.2 SPI modes

The device can be driven by a microcontroller with its SPI peripheral running in one of the two following modes:

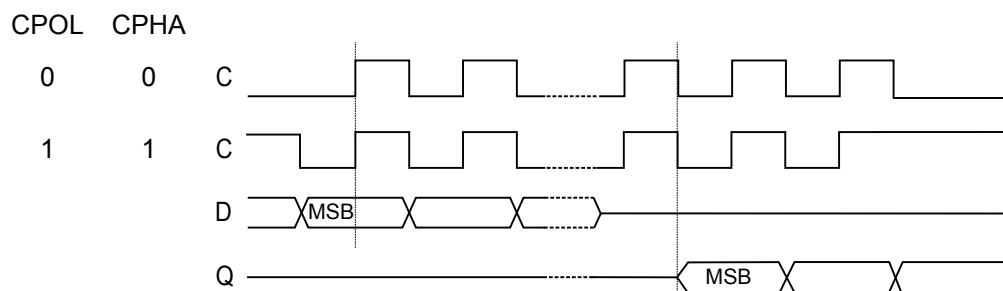
- CPOL = 0, CPHA = 0
- CPOL = 1, CPHA = 1

For these two modes, the input data are latched on the rising edge of the serial clock, and the output data are available from the falling edge of the serial clock.

The difference between the two modes, as shown in Figure 3, is the clock polarity when the bus controller is in standby mode and not transferring data:

- C remains at 0 for (CPOL = 0, CPHA = 0)
- C remains at 1 for (CPOL = 1, CPHA = 1)

Figure 3. Supported SPI modes



DT142674V2

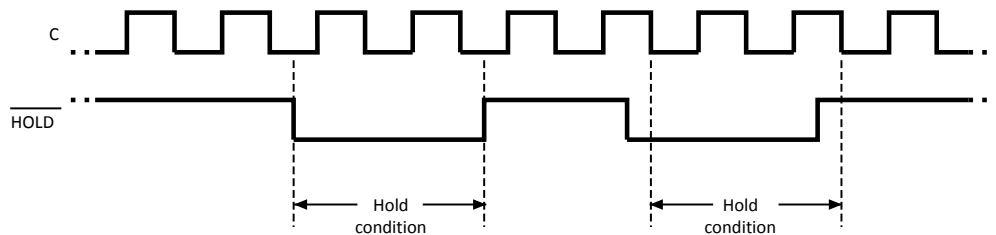


3.3 Hold mode

The hold ($\overline{\text{HOLD}}$) signal is used to pause any serial communications with the device without resetting the clocking sequence.

The hold mode starts when the hold signal is driven low and the serial clock is low (as shown in Figure 4). During the hold mode, the serial data output is high impedance, and the signals present on serial data input and serial clock are not decoded. The hold mode ends when the hold signal is driven high and the C is or becomes low.

Figure 4. Hold mode activation



Deselecting the device while it is in hold mode resets the paused communication.

3.4 Protocol control and data protection

3.4.1 Protocol control

The chip select input offers a built-in safety feature, as it is edge as well as level-sensitive. After power-up, the device is not selected until a falling edge has first been detected. This ensures that chip select must have been high prior to going low, to start the first operation.

To ensure that the write commands (WRITE, WRSR, WRID, LID) are accepted and executed correctly, the following conditions must be met:

- A write enable (WREN) instruction sets the write enable latch (WEL) bit.
- During the entire command, a falling edge followed by a low state on chip select must be decoded.
- The instruction, address, and input data must be sent as multiples of eight bits.
- The command must include at least one data byte.
- The chip select must be driven high exactly after a data byte boundary.

Write commands can be discarded at any time by a rising edge on chip select outside of a byte boundary.

To execute read commands (READ, RDSR, RDID, RDLS), the device must decode:

- A falling edge and a low level on chip select during the entire command
- The instruction and address as multiples of eight bits (byte)

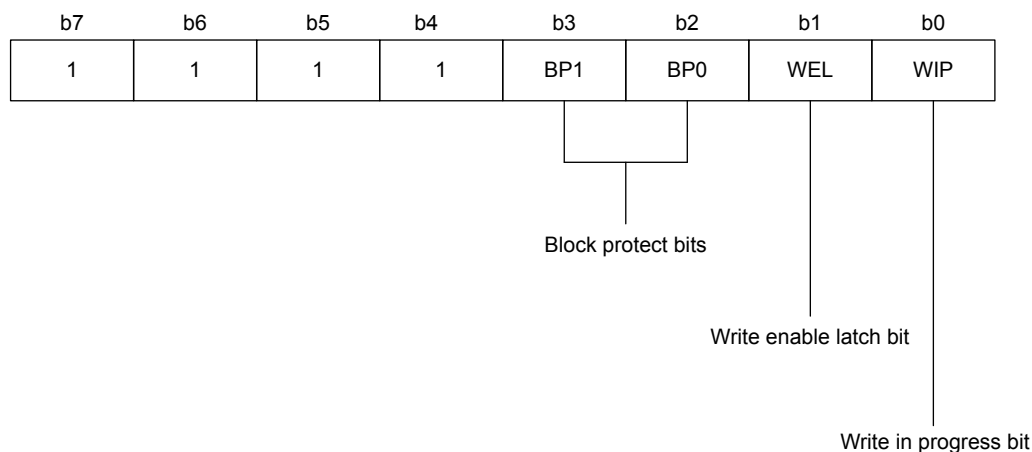
From this step, data bits are shifted out until the rising edge on chip select.



3.4.2 Status register and data protection

The status register format is shown in Figure 5.

Figure 5. Status register format



DT76043V2

Note: The bits b7 to b4 are always read as 1.

WIP bit

The WIP bit (write in progress) is a read-only flag that indicates the ready/busy state of the device. When a write command (WRITE, WRSR, WRID, LID) is decoded and a write cycle (t_w) is in progress, the device is busy, and the WIP bit is set to 1. When WIP = 0, the device is ready to decode a new command.

During a write cycle, continuously reading the WIP bit detects when the device becomes ready (WIP = 0) to decode a new command.

WEL bit

The WEL (write enable latch) bit is a flag that indicates the status of the internal write enable latch.

When WEL is:

- 1: the write instructions (WRITE, WRSR, WRID, and LID) are executed
- 0: any decoded write instruction is not executed

The WEL bit is set to 1 with the WREN instruction, and reset after the following events:

- Completion of the write disable (WRDI) instruction
- Completion of write instructions (WRITE, WRSR, WRID, and LID), including the write cycle time t_w
- Power-up

BP1 and BP0 bits

The block protect bits (BP1, BP0) are nonvolatile. BP1 and BP0 define the size of the memory block to protect against write instructions, as defined in Figure 5. These bits are written using the write status register (WRSR) instruction.



Table 2. Write-protected block size

Status register bits		Protected block	Protected array addresses
BP1	BP0		
0	0	None	None
0	1	Upper quarter	180h - 1FFh
1	0	Upper half	100h - 1FFh
1	1	Whole memory	000h - 1FFh, and the identification page

3.5 Identification page

The M95040-A125 and M95040-A145 offer an identification page (16-byte) in addition to the 4-Kbit memory. The identification page contains two fields:

- Device identification: the first three bytes are programmed by STMicroelectronics with the device identification code, as shown in Table 3.
- Application parameters: the byte after the device identification code is available for application-specific data.

Note: If the end application does not need to read the device identification code, this field can be overwritten and used to store application-specific data. Once these data are written, the whole identification page should be permanently locked in read-only mode.

The read, write, lock identification page instructions are detailed in Instructions.

Table 3. Device identification bytes

Address in identification page	Content	Value
00h	ST manufacturer code	20h
01h	SPI family code	00h
02h	Memory density code	09h (4-Kbitt)



4 Instructions

Each command is composed of bytes (the most significant bit, MSB, is transmitted first), initiated with the instruction byte, as summarized in Table 4.

If an invalid instruction is sent (one not contained in Table 4), the device automatically enters a wait state until deselected.

Table 4. Instruction set

Instruction	Description	Instruction format
WREN	Write enable	0000 X110 ⁽¹⁾
WRDI	Write disable	0000 X100
RDSR	Read status register	0000 X101
WRSR	Write status register	0000 X001
READ	Read from memory array	0000 A8011 ⁽²⁾
WRITE	Write to memory array	0000 A8010 ⁽²⁾
RDID	Read identification page	1000 0011
WRID	Write identification page	1000 0010
RDLS	Reads the identification page lock status	1000 0011
LID	Locks the identification page in read-only mode	1000 0010

1. X = don't care.

2. A8 = 1 for the upper half of the memory array and 0 for the lower half.

For read and write commands in the memory array and identification page, the address is defined through one address byte and one bit (b3) of the instruction byte as explained in Table 5.

Table 5. Significant bits within the address byte

Instruction	Bit b3 of the instruction byte								LSB address byte							
									b7	b6	b5	b4	b3	b2	b1	b0
READ or WRITE	X ⁽¹⁾	X	X	X	X	X	X	A8 ⁽²⁾	A7	A6	A5	A4	A3	A2	A1	A0
RDID or WRID	0	0	0	0	0	0	0	0	0	0	0	A4	A3	A2	A1	A0
RDLS or LID	0	0	0	0	0	0	0	0	1	0	0	0	0	0	0	0

1. X = The bit is don't care.

2. A: Significant address bit.

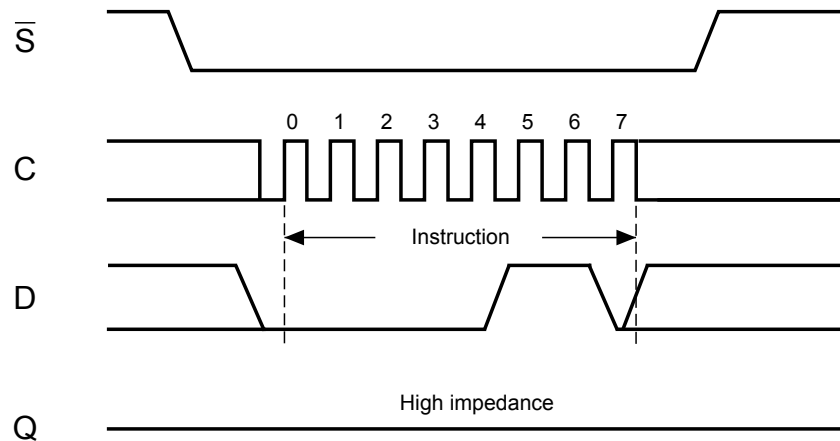


4.1 Write enable (WREN)

The write enable latch (WEL) bit must be set before each WRITE, WRSR, WRID, and LID instruction. The only way to do this is to send a write enable instruction to the device.

As shown in Figure 6, to send this instruction to the device, chip select (\bar{S}) is driven low, and the bits of the instruction byte are shifted in on serial data input (D). The device then enters a wait state and waits to be deselected by \bar{S} being driven high, and the WEL bit is set.

Figure 6. Write enable (WREN) sequence



DIT1377V1

4.2 Write disable (WRDI)

One way to reset the WEL bit is to send a write disable instruction to the device.

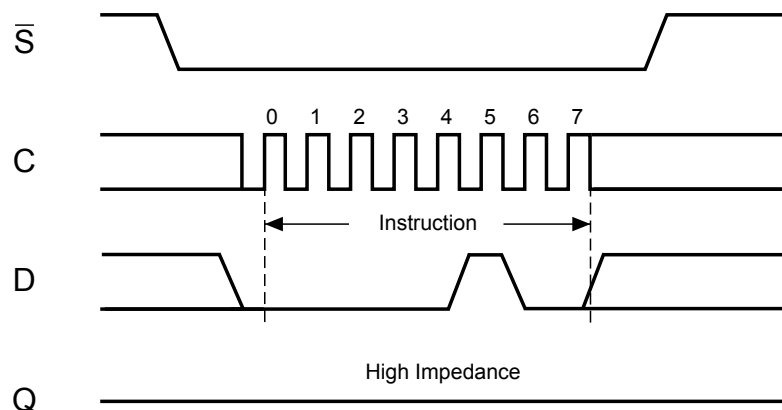
As shown in Figure 7, to send this instruction to the device, chip select (\bar{S}) is driven low, and the bits of the instruction byte are shifted in on serial data input (D). The device then enters a wait state and waits for the device to be deselected, by \bar{S} being driven high.

If a write cycle is currently in progress, the WRDI instruction is decoded and executed. The WEL bit is reset to 0 with no effect on the ongoing write cycle.

The write enable latch (WEL) bit, in fact, becomes reset by any of the following events:

- Power-up
- WRDI instruction execution
- WRSR instruction completion
- WRITE instruction completion
- Write protect (\bar{W}) line being held low

Figure 7. Write disable (WRDI) sequence



DIT1378V1



4.3 Read status register (RDSR)

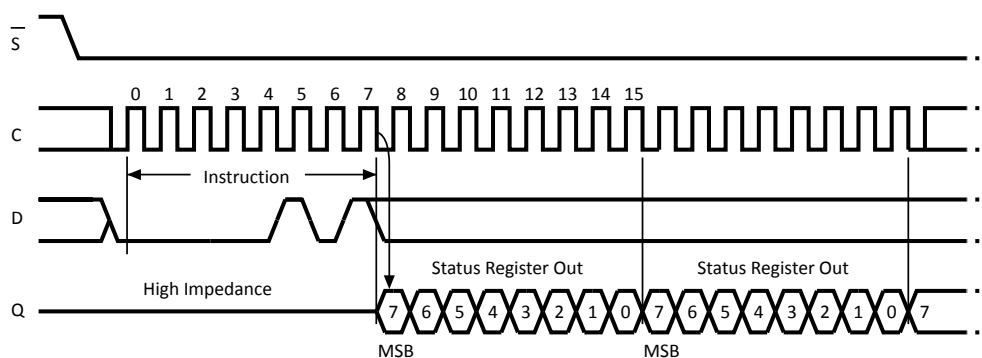
The read status register (RDSR) instruction is used to read the content of the status register.

As shown in Figure 8, to send this instruction to the device, chip select is first driven low. The bits of the instruction byte are shifted in (MSB first) on serial data input, the status register content is then shifted out (MSB first) on serial data output.

If chip select continues to be driven low, the status register content is continuously shifted out.

The status register can always be read, even if a write cycle (t_W) is in progress. The status register functionality is detailed in Section 3.4.2: Status register and data protection.

Figure 8. Read status register (RDSR) sequence





4.4 Write status register (WRSR)

The write status register (WRSR) instruction allows new values to be written to the status register. Before it can be accepted, a write enable (WREN) instruction must previously have been executed.

The write status register (WRSR) instruction is entered (MSB first) by driving chip select (\overline{S}) low, sending the instruction code followed by the data byte on serial data input (D), and driving the chip select (\overline{S}) signal high.

This instruction allows the user to change the values of the BP1 and BP0 bits which define the size of the area that is to be treated as read only, as defined in Table 2. Write-protected block size.

The contents of the BP1 and BP0 bits are updated after the completion of the WRSR instruction, including the write cycle (t_W).

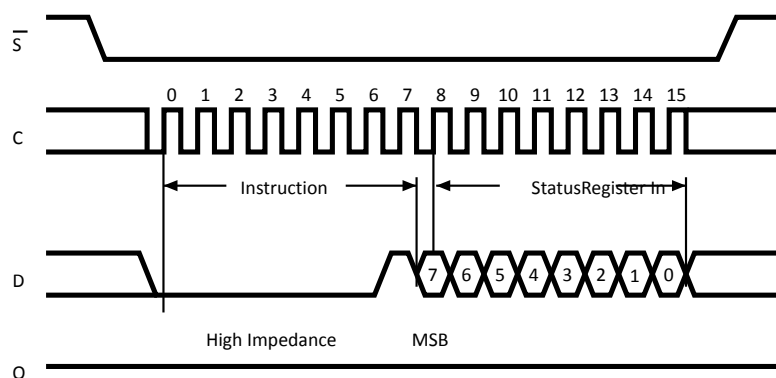
The write status register (WRSR) instruction has no effect on bits from b7 to b4, b1, and b0 bits in the status register (see Figure 5. Status register format).

The status register functionality is detailed in Section 3.4.2: Status register and data protection.

The instruction is not accepted, and is not executed under the following conditions:

- If the write enable latch (WEL) bit has not been set to 1 by executing a write enable instruction just before.
- If a write cycle is already in progress.
- If the device has not been deselected by chip select (\overline{S}) being driven high, after the eighth bit, b0, of the data byte has been latched in.
- If write protect (\overline{W}) is low during the WRSR command (instruction, address, and data).

Figure 9. Write status register (WRSR) sequence





4.5 Read from memory array (READ)

The READ instruction is used to read the content of the memory.

As shown in Figure 10, to send this instruction to the device, chip select (\bar{S}) is first driven low.

The bits of the instruction byte and address bytes are shifted in (MSB first) on serial data input (D). The most significant address bit, A8, is embedded as bit b3 of the instruction byte, as shown in Table 4. Instruction set. The address is loaded into an internal address register, and the byte of data at that address is shifted out on serial data output (Q).

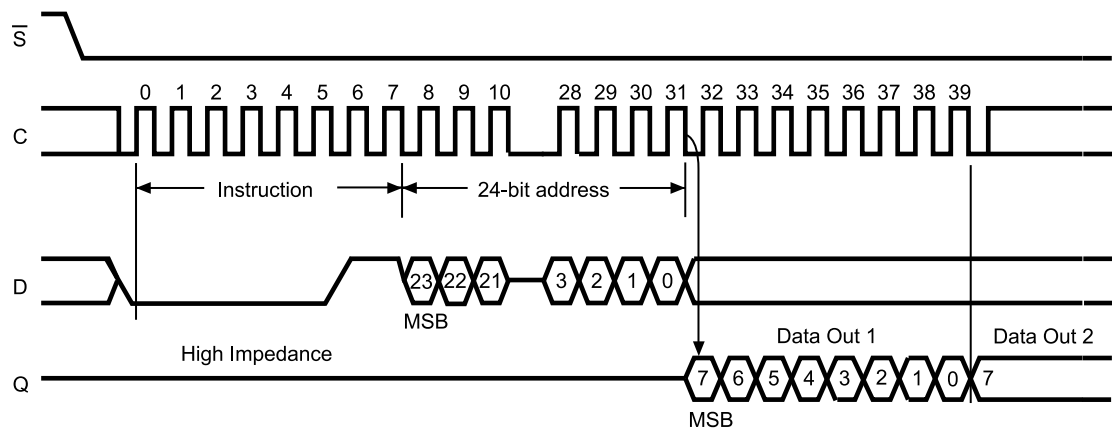
If chip select (\bar{S}) continues to be driven low, the internal address register is automatically incremented, and the next byte of data is shifted out. The whole memory can therefore be read with a single READ instruction.

When the highest address is reached, the address counter rolls over to zero, allowing the read cycle to continue indefinitely.

The read cycle is terminated by driving chip select (\bar{S}) high at any time when the data bits are shifted out on serial data output (Q).

The instruction is not accepted, and is not executed, if a write cycle is currently in progress.

Figure 10. Read from memory array (READ) sequence



1. Depending on the memory size, as shown in Table 5, the most significant address bits are don't care.

DT13878aV3

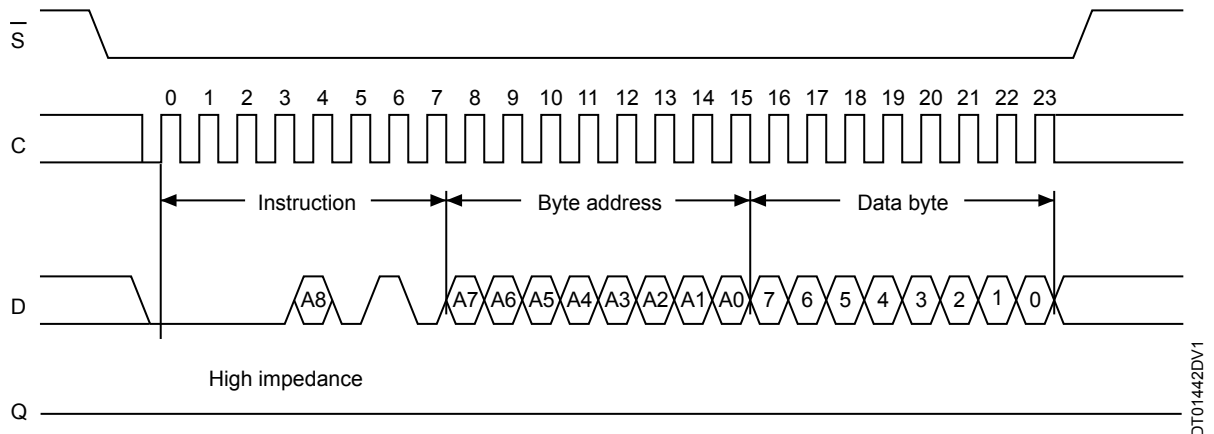


4.6 Write to memory array (WRITE)

The WRITE instruction is used to write new data in the memory.

As shown in Figure 11, to send this instruction to the device, chip select (\overline{S}) is first driven low. The bits of the instruction byte, address byte, and at least one data byte are then shifted in (MSB first) on the serial data input (D). The most significant address bit, A8, is embedded as bit b3 of the instruction byte, as shown in Table 4. Instruction set. The instruction is terminated by driving chip select (S) high at a data byte boundary. Figure 11 shows a single byte write.

Figure 11. Byte write (WRITE) sequence



DT01442DV1

A page write is used to write several bytes of the same page with a single internal write cycle.

For a page write, chip select (\overline{S}) has to remain low, as shown in Figure 12, so that the next data bytes are shifted in. Each time a new data byte is shifted in, the least significant bits of the internal address counter are incremented. If the address counter exceeds the page boundary (the page size is 16-byte), the internal address pointer rolls over to the beginning of the same page where the next data bytes are written. If more than 16-byte are received, only the last 16-byte are written.

For both byte write and page write, the self-timed write cycle starts from the rising edge of chip select (\overline{S}), and continues for a period t_W (as specified in Table 13).

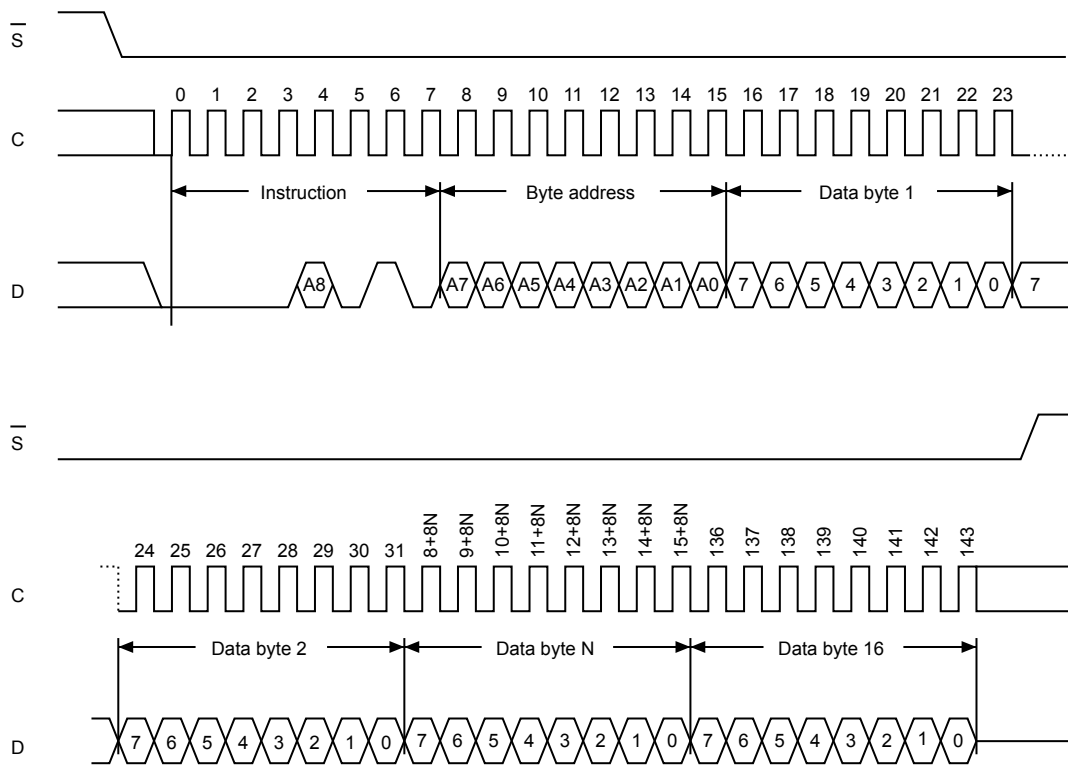
The instruction is discarded, and is not executed, under the following conditions:

- If a write cycle is already in progress
- If the write protect (\overline{W}) is low or if the addressed page is in the region protected by the block protect (BP1 and BP0) bits
- If one of the conditions defined in Section 3.4.1: Protocol control is not satisfied

Note: The self-timed write cycle t_W is internally executed as a sequence of two consecutive events: [erase addressed byte(s)], followed by [program addressed byte(s)]. An erased bit is read as 0 and a programmed bit is read as 1.



Figure 12. Page write (WRITE) sequence



DTT604V1



4.7 Read identification page (RDID)

This instruction is used to read the identification page.

The chip select (\bar{S}) signal is first driven low. The bits of the instruction byte and address byte are then shifted in (MSB first) on serial data input (D). Address bit A8 must be 0 and the other upper address bits are don't care (it might be easier to define these bits as 0). The data byte pointed to by the lower address bits [A4:A0] is shifted out (MSB first) on serial data output (Q).

The first byte addressed can be any byte within the identification page.

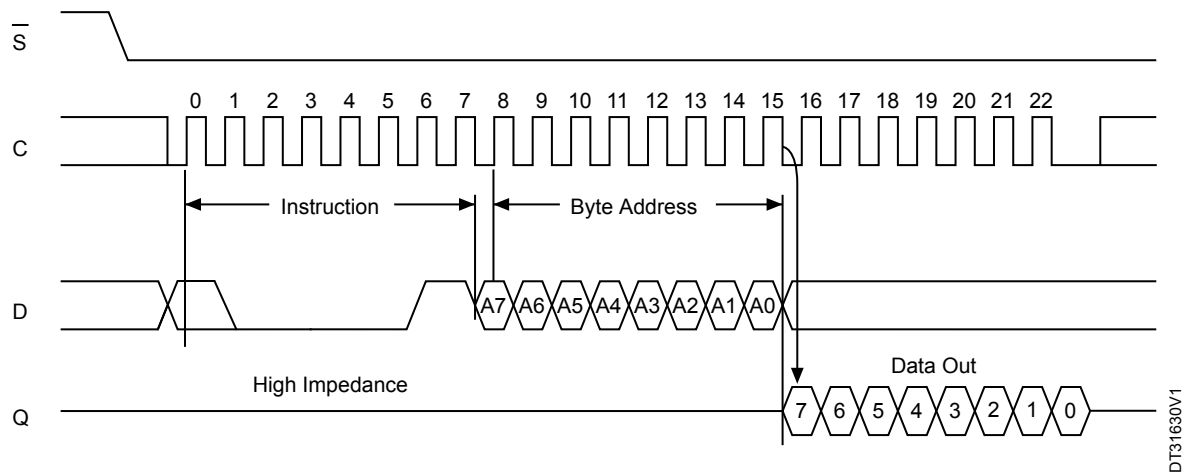
If chip select (\bar{S}) continues to be driven low, the internal address register is automatically incremented and the byte of data at the new address is shifted out.

Note: *There is no roll-over feature in the identification page. The address of the byte to read must not exceed the page boundary.*

The read cycle is terminated by driving chip select (\bar{S}) high. The rising edges of the chip select (\bar{S}) signal can occur at any time when the data bits are shifted out.

The instruction is not accepted, and is not executed, if a write cycle is currently in progress.

Figure 13. Read identification page sequence



The first three bytes of the identification page provide information about the device itself. Refer to [Section 3.5: Identification page](#) for more information.



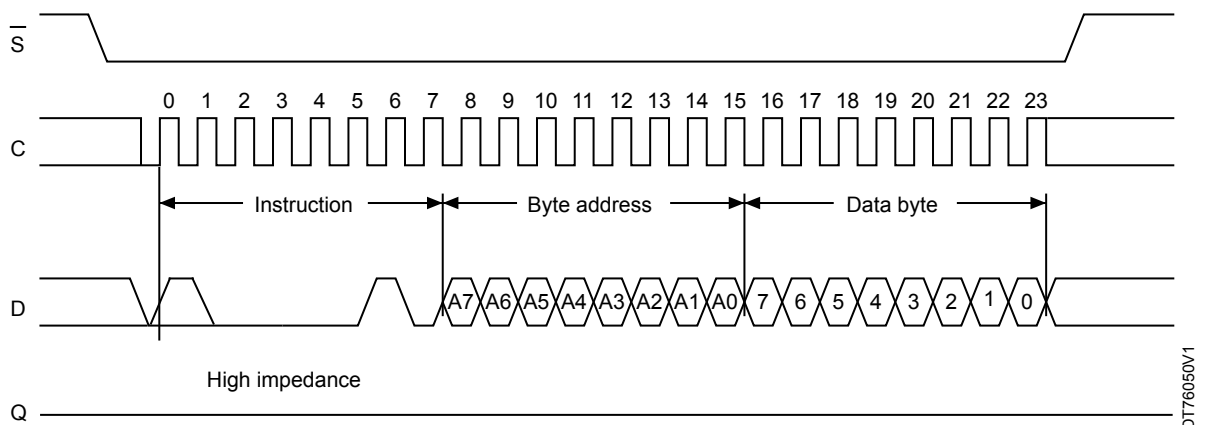
4.8 Write identification page (WRID)

This instruction is used to write the identification page.

The chip select signal (\bar{S}) is first driven low, and then the bits of the instruction byte, address byte, and at least one data byte are shifted in (MSB first) on serial data input (D). The address bit A8 must be 0 and the other upper address bits are don't care (it might be easier to define these bits as 0). The lower address bits [A4:A0] define the byte address inside the identification page.

The self-timed write cycle starts from the rising edge of chip select (\bar{S}), and continues for a period t_W (as specified in Table 13).

Figure 14. Write identification page sequence



DT76050V1

Note: The first three bytes of the identification page offer the device identification code (refer to Section 3.5: Identification page for more information). Using the WRID command on the first three bytes overwrites the device identification code.

The instruction is discarded, and is not executed, under the following conditions:

- If a write cycle is already in progress
- If the block protect bits (BP1,BP0) = (1,1)
- If one of the conditions defined in Section 3.4.1: Protocol control is not satisfied.



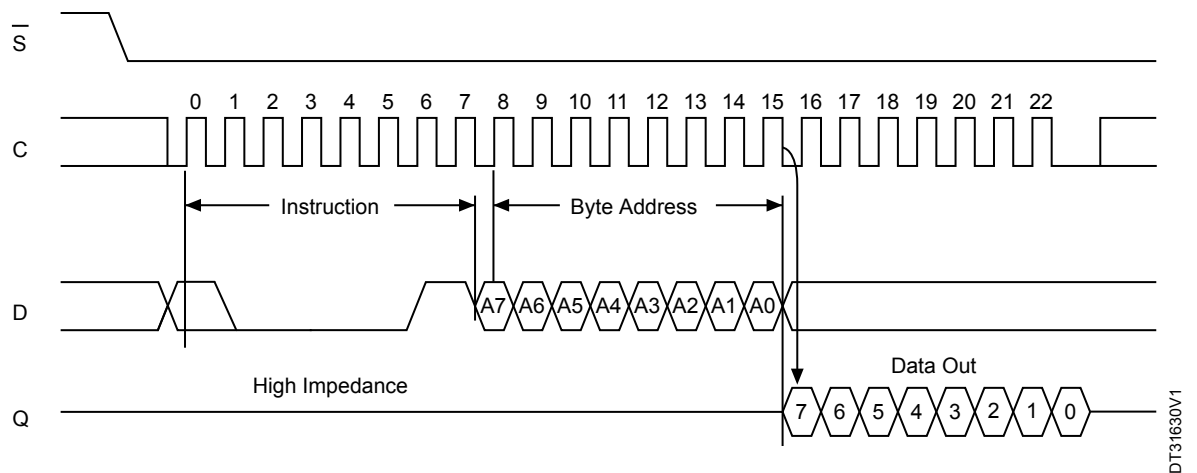
4.9 Read lock status (RDLS)

The read lock status instruction (see [Section 4: Instructions](#)) is used to check whether the identification page is locked or not in read-only mode. The read lock status sequence is defined with the chip select (\overline{S}) first driven low. The bits of the instruction byte and address bytes are then shifted in on serial data input (D). Address bit A7 must be 1; all other address bits are don't care. The lock bit is the LSB (least significant bit) of the byte read on serial data output (Q). It is at 1 when the lock is active and at 0 when the lock is not active. If chip select (\overline{S}) continues to be driven low, the same data byte is shifted out. The read cycle is terminated by driving chip select (\overline{S}) high.

The read lock status instruction is not accepted and not executed if a write cycle is currently in progress.

The instruction sequence is shown in [Figure 15](#).

Figure 15. Read lock status sequence



4.10 Lock identification page (LID)

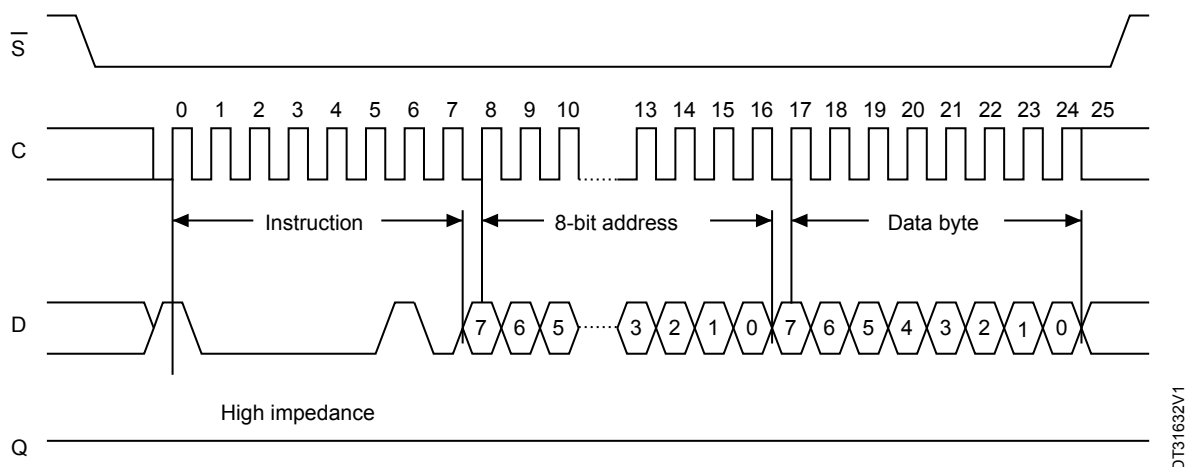
The LID command is used to permanently lock the identification page in read-only mode.

The LID instruction is issued by:

- Driving chip select (\overline{S}) low
- Sending (MSB first) the instruction code, the address and a data byte on serial data input (D)
- Driving chip select (\overline{S}) high

In the address sent, A7 must be equal to 1. All other address bits are don't care (it is easier to define these bits as 0, as shown in [Table 5](#)). The data byte sent must be equal to the binary value xxxx xx1x, where x = don't care.

The LID instruction is terminated by driving chip select (\overline{S}) high at a data byte boundary, otherwise, the instruction is not executed.


Figure 16. Lock ID sequence


DT31632V1

Driving chip select (\bar{S}) high at a byte boundary of the input data triggers the self-timed write cycle which duration is t_W (specified in Table 13). The instruction sequence is shown in Figure 16.

The instruction is discarded, and is not executed, under the following conditions:

- If a write cycle is already in progress
- If (BP1, BP0) = (1,1)
- If one of the conditions defined in Section 3.4.1: Protocol control is not satisfied



5 Application design recommendations

5.1 Supply voltage (V_{CC})

5.1.1 Operating supply voltage (V_{CC})

Before selecting the memory and issuing instructions to it, a valid and stable V_{CC} voltage within the specified [$V_{CC(min)}$, $V_{CC(max)}$] range must be applied (see [Table 11](#) and [Table 12](#)).

This voltage must remain stable and valid until the end of the transmission of the instruction and, for a write instruction, until the completion of the internal write cycle (t_W). To secure a stable DC supply voltage, it is recommended to decouple the V_{CC} line with a suitable capacitor (usually 10 nF to 100 nF) close to the V_{CC}/V_{SS} package pins.

5.1.2 Power-up conditions

When the power supply is turned on, V_{CC} continuously rises from V_{SS} to V_{CC} . During this time, the chip select (\bar{S}) line is not allowed to float but must follow the V_{CC} voltage. The \bar{S} line must be connected to V_{CC} via a suitable pull-up resistor (see [Figure 17. Bus controller and memory devices on the SPI bus](#)).

The V_{CC} voltage has to rise continuously from 0 V up to the minimum V_{CC} operating voltage defined in [Table 11](#) and [Table 12](#).

To prevent inadvertent write operations during power-up, a power-on-reset (POR) circuit is included.

At power-up, the device does not respond to any instruction until V_{CC} reaches the internal threshold voltage (this threshold is defined in the [Table 11](#) and [Table 12](#) as V_{RES}).

When V_{CC} passes over the POR threshold, the device is reset and in the following state:

- Standby power mode
- Deselected
- Status register values:
 - Write enable latch (WEL) bit is reset to 0.
 - Write in progress (WIP) bit is reset to 0.
 - BP1, and BP0 bits remain unchanged (nonvolatile bits).
- Not in the hold condition

When the V_{CC} has reached a stable value within the [$V_{CC(min)}$, $V_{CC(max)}$] range, the device is ready to operate.



5.1.3 Power-down

During power-down, when V_{CC} continuously decreases below the minimum operating voltage defined in Table 11 and Table 12, the device must be:

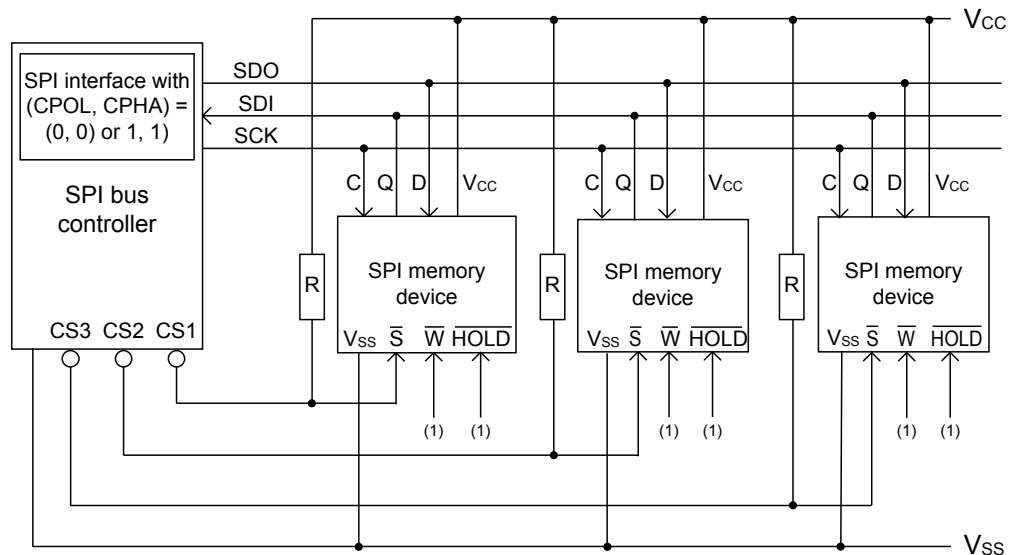
- Deselected (chip select \overline{S}) must be allowed to follow the voltage applied on V_{CC})
- Standby power mode (there must not be any internal write cycle in progress).

Similarly to power-up, during power-down, when V_{CC} decreases, the device must not be accessed when V_{CC} drops below $V_{CC}(\min)$. When V_{CC} drops below the power-on-reset threshold voltage, the device stops responding to any instructions sent to it.

5.2 Implementing devices on SPI bus

Figure 17 shows an example of three devices, connected to the SPI bus controller. Only one device is selected at a time, so that only the selected device drives the serial data output (Q) line. All the other devices outputs are then in high impedance.

Figure 17. Bus controller and memory devices on the SPI bus



DT74592V2

Note: The write protect (\overline{W}) and hold (\overline{HOLD}) signals must be driven high or low as appropriate.

A pull-up resistor connected on each \overline{S} input (represented in Figure 17) ensures that each device is not selected if the bus controller leaves the \overline{S} line in the high impedance state.

5.3 ECC (error correction code)

The error correction code (ECC x 1) is an internal logic function, which is transparent for the SPI communication protocol.

The ECC x 1 logic is implemented on each byte of the memory array. If a single bit out of the byte happens to be erroneous during a read operation, the ECC x 1 detects this bit and replaces it with the correct value. The read reliability is therefore much improved.



6 Delivery state

The device is delivered with:

- The memory array set to all 1s (each byte = FFh)
- Status register: bit BP1 = 0 and BP0 = 0
- Identification page: the first three bytes define the device identification code (value defined in [Table 3](#)). The content of the following byte is don't care.



7 Absolute maximum ratings

Stressing the device outside the ratings listed in Table 6 can permanently damage it. These are stress ratings only, and operation of the device at these, or any other conditions outside those indicated in the operating sections of this specification, is not implied. Exposure to absolute maximum rating conditions for extended periods may affect device reliability.

Table 6. Absolute maximum ratings

Symbol	Parameter	Min.	Max.	Unit
T _{AMB}	Ambient operating temperature	-40	150	°C
T _{STG}	Storage temperature	-65	150	
T _{LEAD}	Lead temperature during soldering	See note ⁽¹⁾		
V _O	Output voltage on Q pin	-0.50	V _{CC} + 0.6	V
V _I	Input voltage	-0.50	6.5	
I _{OL}	DC output current (Q = 0)	-	5	mA
I _{OH}	DC output current (Q = 1)	-	5	
V _{CC}	Supply voltage	-0.50	6.5	V
V _{ESD}	Electrostatic discharge voltage (human body model) ⁽²⁾	-	4000	V

1. Compliant with JEDEC standard J-STD-020 (for small-body, Sn-Pb or Pb free assembly), the ST ECOPACK 7191395 specification, and the European directive on restrictions on hazardous substances (RoHS directive 2011/65/EU of July 2011).
2. Positive and negative pulses are applied to pin pairs in accordance with AEC-Q100-002, compliant with ANSI/ESDA/JEDEC JS-001, C1 = 100 pF, R1 = 1500 Ω, R2 = 500 Ω).



8 DC and AC parameters

This section summarizes the operating conditions and the DC/AC characteristics of the device.

Table 7. Cycling performance by byte

Symbol	Parameter	Conditions	Min.	Max.	Unit
NCycle	Write cycles endurance	$T_A \leq 25\text{ °C}$, $1.7\text{ V} \leq V_{CC} \leq 5.5\text{ V}$	-	4 000 000	Write cycles ⁽¹⁾
		$T_A = 85\text{ °C}$, $1.7\text{ V} \leq V_{CC} \leq 5.5\text{ V}$	-	1 200 000	
		$T_A = 125\text{ °C}$, $1.7\text{ V} \leq V_{CC} \leq 5.5\text{ V}$	-	600 000	
		$T_A = 145\text{ °C}^{(2)}$, $2.5\text{ V} \leq V_{CC} \leq 5.5\text{ V}$	-	400 000	

1. A write cycle is executed when either a page write, a byte write, a WRSR, a WRID, or a LID instruction is decoded. When using the byte write, the page write or the WRID, refer also to [Section 5.3: ECC \(error correction code\)](#).
2. For temperature range 4 only.

Table 8. Operating conditions (voltage range W, temperature range 4)

Symbol	Parameter	Conditions	Min.	Max.	Unit
V_{CC}	Supply voltage	-	2.5	5.5	V
T_A	Ambient operating temperature	-	-40	145	°C
f_C	Operating clock frequency	$5.5\text{ V} \geq V_{CC} \geq 2.5\text{ V}$, capacitive load on Q pin $\leq 100\text{ pF}$	-	10	MHz

Table 9. Operating conditions (voltage range R, temperature range 3)

Symbol	Parameter	Conditions	Min.	Max.	Unit
V_{CC}	Supply voltage	-	1.7	5.5	V
T_A	Ambient operating temperature	-	-40	125	°C
f_C	Operating clock frequency	$V_{CC} \geq 2.5\text{ V}$, capacitive load on Q pin $\leq 100\text{ pF}$	-	10	MHz
		$V_{CC} \geq 1.7\text{ V}$, capacitive load on Q pin $\leq 100\text{ pF}$	-	5	

Table 10. Operating conditions (voltage range R, temperature range 3) for high-speed communications

Symbol	Parameter	Conditions	Min.	Max.	Unit
V_{CC}	Supply voltage	-	4.5	5.5	V
T_A	Ambient operating temperature	-	-40	85	°C
f_C	Operating clock frequency	$V_{CC} \geq 4.5\text{ V}$, capacitive load on Q pin $\leq 60\text{ pF}$	-	20	MHz



Table 11. DC characteristics (voltage range W, temperature range 4)

Symbol	Parameter	Test conditions (in addition to the conditions specified in Table 8)	Min.	Max.	Unit
$C_{OUT}^{(1)}$	Output capacitance (Q)	$V_{OUT} = 0\text{ V}$	-	8	pF
$C_{IN}^{(1)}$	Input capacitance	$V_{IN} = 0\text{ V}$	-	6	
I_{LI}	Input leakage current	$V_{IN} = V_{SS}$ or V_{CC}	-	2	μA
I_{LO}	Output leakage current	$\bar{S} = V_{CC}$, $V_{OUT} = V_{SS}$ or V_{CC}	-	3	
I_{CC}	Supply current (read)	$V_{CC} = 2.5\text{ V}$, $f_C = 10\text{ MHz}$, $C = 0.1 V_{CC}/0.9 V_{CC}$, Q = open	-	2	mA
		$V_{CC} = 5.5\text{ V}$, $f_C = 10\text{ MHz}$, $C = 0.1 V_{CC}/0.9 V_{CC}$, Q = open	-	4	
I_{CC0}	Supply current (write)	$2.5\text{ V} \leq V_{CC} < 5.5\text{ V}$, averaged during t_W , $\bar{S} = V_{CC}$	-	2 ⁽¹⁾	mA
I_{CC1}	Supply current (Standby mode)	$T_A = 85\text{ °C}$, $V_{CC} = 2.5\text{ V}$, $\bar{S} = V_{CC}$ $V_{IN} = V_{SS}$ or V_{CC}	-	2	μA
		$T_A = 85\text{ °C}$, $V_{CC} = 5.5\text{ V}$, $\bar{S} = V_{CC}$ $V_{IN} = V_{SS}$ or V_{CC}	-	3	
		$T_A = 125\text{ °C}$, $V_{CC} = 2.5\text{ V}$, $\bar{S} = V_{CC}$ $V_{IN} = V_{SS}$ or V_{CC}	-	15	
		$T_A = 125\text{ °C}$, $V_{CC} = 5.5\text{ V}$, $\bar{S} = V_{CC}$ $V_{IN} = V_{SS}$ or V_{CC}	-	20	
		$T_A = 145\text{ °C}$, $V_{CC} = 2.5\text{ V}$, $\bar{S} = V_{CC}$ $V_{IN} = V_{SS}$ or V_{CC}	-	25	
		$T_A = 145\text{ °C}$, $V_{CC} = 5.5\text{ V}$, $\bar{S} = V_{CC}$ $V_{IN} = V_{SS}$ or V_{CC}	-	40	
		$T_A = 145\text{ °C}$, $V_{CC} = 5.5\text{ V}$, $\bar{S} = V_{CC}$ $V_{IN} = V_{SS}$ or V_{CC}	-	40	
V_{IL}	Input low voltage	-	-0.45	$0.3 V_{CC}$	V
V_{IH}	Input high voltage	-	$0.7 V_{CC}$	$V_{CC} + 1$	
V_{OL}	Output low voltage	$I_{OL} = 2\text{ mA}$	-	0.4	
V_{OH}	Output high voltage	$I_{OH} = -2\text{ mA}$	$0.8 V_{CC}$	-	
$V_{RES}^{(1)}$	Internal reset threshold voltage	-	0.5	1.5	

1. Evaluated by characterization - Not tested in production.



Table 12. DC characteristics (voltage range R, temperature range 3)

Symbol	Parameter	Test conditions (in addition to the conditions specified in Table 9)	Min.	Max.	Unit
$C_{OUT}^{(1)}$	Output capacitance (Q)	$V_{OUT} = 0\text{ V}$	-	8	pF
$C_{IN}^{(1)}$	Input capacitance	$V_{IN} = 0\text{ V}$	-	6	
I_{LI}	Input leakage current	$V_{IN} = V_{SS}\text{ or }V_{CC}$	-	2	μA
I_{LO}	Output leakage current	$\bar{S} = V_{CC}, V_{OUT} = V_{SS}\text{ or }V_{CC}$	-	3	
I_{CC}	Supply current (read)	$V_{CC} = 1.7\text{ V}, f_C = 5\text{ MHz},$ $C = 0.1\text{ V}_{CC}/0.9\text{ V}_{CC}, Q = \text{open}$	-	2	mA
		$V_{CC} = 2.5\text{ V}, f_C = 10\text{ MHz},$ $C = 0.1\text{ V}_{CC}/0.9\text{ V}_{CC}, Q = \text{open}$	-	2	
		$V_{CC} = 5.5\text{ V}, f_C = 20\text{ MHz}^{(2)}$ $C = 0.1\text{ V}_{CC}/0.9\text{ V}_{CC}, Q = \text{open}$	-	5	
I_{CC0}	Supply current (write)	$1.7\text{ V} \leq V_{CC} < 5.5\text{ V}$, averaged during t_W , $\bar{S} = V_{CC}$	-	$2^{(1)}$	mA
I_{CC1}	Supply current (Standby power mode)	$T_A = 85\text{ }^\circ\text{C}, V_{CC} = 1.7\text{ V}, \bar{S} = V_{CC}$ $V_{IN} = V_{SS}\text{ or }V_{CC}$	-	1	μA
		$T_A = 85\text{ }^\circ\text{C}, V_{CC} = 2.5\text{ V}, \bar{S} = V_{CC}$ $V_{IN} = V_{SS}\text{ or }V_{CC}$	-	2	
		$T_A = 125\text{ }^\circ\text{C}, V_{CC} = 5.5\text{ V}, \bar{S} = V_{CC}$ $V_{IN} = V_{SS}\text{ or }V_{CC}$	-	3	
		$T_A = 125\text{ }^\circ\text{C}, V_{CC} = 1.7\text{ V}, \bar{S} = V_{CC}$ $V_{IN} = V_{SS}\text{ or }V_{CC}$	-	15	
		$T_A = 125\text{ }^\circ\text{C}, V_{CC} = 2.5\text{ V}, \bar{S} = V_{CC}$ $V_{IN} = V_{SS}\text{ or }V_{CC}$	-	15	
		$T_A = 125\text{ }^\circ\text{C}, V_{CC} = 5.5\text{ V}, \bar{S} = V_{CC}$ $V_{IN} = V_{SS}\text{ or }V_{CC}$	-	20	
V_{IL}	Input low voltage	$1.7\text{ V} \leq V_{CC} < 2.5\text{ V}$	-0.45	0.25 V_{CC}	V
		$2.5\text{ V} \leq V_{CC} < 5.5\text{ V}$	-0.45	0.3 V_{CC}	
V_{IH}	Input high voltage	$1.7\text{ V} \leq V_{CC} < 2.5\text{ V}$	0.75 V_{CC}	$V_{CC} + 1$	
		$2.5\text{ V} \leq V_{CC} < 5.5\text{ V}$	0.7 V_{CC}	$V_{CC} + 1$	
V_{OL}	Output low voltage	$V_{CC} = 1.7\text{ V}, I_{OL} = 1\text{ mA}$	-	0.3	
		$V_{CC} \geq 2.5\text{ V}, I_{OL} = 2\text{ mA}$	-	0.4	
V_{OH}	Output high voltage	$V_{CC} = 1.7\text{ V}, I_{OH} = 1\text{ mA}$	0.8 V_{CC}	-	
		$V_{CC} \geq 2.5\text{ V}, I_{OH} = -2\text{ mA}$	0.8 V_{CC}	-	
$V_{RES}^{(1)}$	Internal reset threshold voltage	-	0.5	1.5	

1. Evaluated by characterization - Not tested in production.

2. When $-40\text{ }^\circ\text{C} < T_A < 85\text{ }^\circ\text{C}$.



Table 13. AC characteristics

Symbol	Alt.	Parameter	Min.	Max.	Min	Max.	Min	Max.	Unit
			Test conditions specified in Table 9		Test conditions specified in Table 8 and Table 9		Test conditions specified in Table 10		
f_C	f_{SCK}	Clock frequency	-	5	-	10	-	20	MHz
t_{SLCH}	t_{CSS1}	\bar{S} active setup time	60	-	30	-	15	-	ns
t_{SHCH}	t_{CSS2}	\bar{S} not active setup time	60	-	30	-	15	-	
t_{SHSL}	t_{CS}	\bar{S} deselect time	90	-	40	-	20	-	
t_{CHSH}	t_{CSH}	\bar{S} active hold time	60	-	30	-	15	-	
t_{CHSL}	-	\bar{S} not active hold time	60	-	30	-	15	-	
$t_{CH}^{(1)}$	t_{CLH}	Clock high time	80	-	40	-	20	-	
$t_{CL}^{(1)}$	t_{CLL}	Clock low time	80	-	40	-	20	-	
$t_{CLCH}^{(2)}$	t_{RC}	Clock rise time	-	2	-	2	-	2	μ s
$t_{CHCL}^{(2)}$	t_{FC}	Clock fall time	-	2	-	2	-	2	
t_{DVCH}	t_{DSU}	Data in setup time	20	-	10	-	5	-	ns
t_{CHDX}	t_{DH}	Data in hold time	20	-	10	-	10	-	
t_{HHCH}	-	Clock low hold time after HOLD not active	60	-	30	-	15	-	
t_{HLCH}	-	Clock low hold time after HOLD active	60	-	30	-	15	-	
t_{CLHL}	-	Clock low set-up time before HOLD active	0	-	0	-	0	-	
t_{CLHH}	-	Clock low set-up time before HOLD not active	0	-	0	-	0	-	
$t_{SHQZ}^{(2)}$	t_{DIS}	Output disable time	-	80	-	40	-	20	
$t_{CLQV}^{(3)}$	t_V	Clock low to output valid	-	80	-	40	-	20	
t_{CLQX}	t_{HO}	Output hold time	0	-	0	-	0	-	
$t_{QLQH}^{(2)}$	t_{RO}	Output rise time	-	20	-	20	-	20	
$t_{QHQL}^{(2)}$	t_{FO}	Output fall time	-	20	-	20	-	20	
t_{HHQV}	t_{LZ}	HOLD high to output valid	-	80	-	40	-	20	
$t_{HLQZ}^{(2)}$	t_{HZ}	HOLD low to output high-Z	-	80	-	40	-	20	
t_W	t_{WC}	Write time	-	4	-	4	-	4	ms

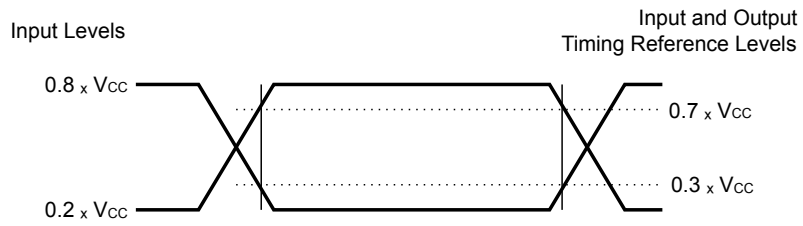
1. $t_{CH} + t_{CL}$ must never be lower than the shortest possible clock period, $1/f_C(\max)$.

2. Evaluated by characterization - Not tested in production.

3. t_{CLQV} must be compatible with t_{CL} (clock low time): if t_{SU} is the Read setup time of the SPI bus master, t_{CL} must be equal to (or greater than) $t_{CLQV} + t_{SU}$.

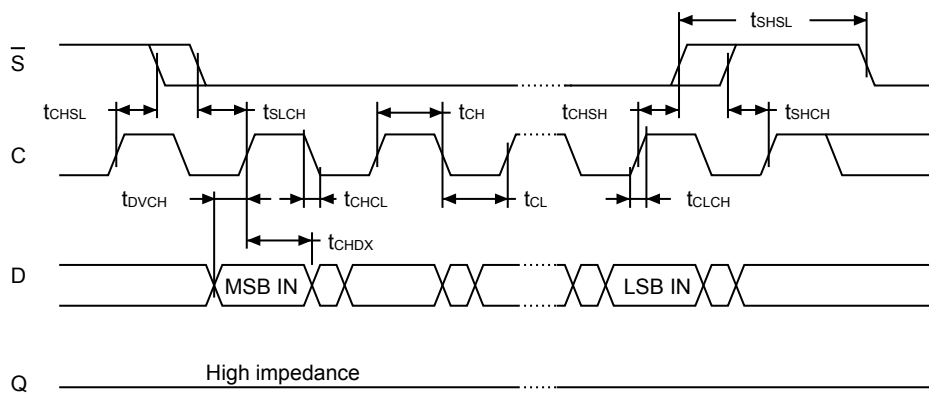


Figure 18. AC measurement I/O waveform



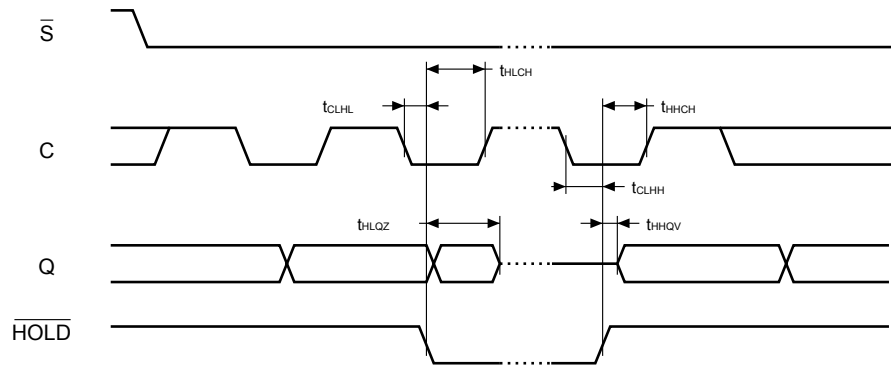
DT00825cV2

Figure 19. Serial input timing

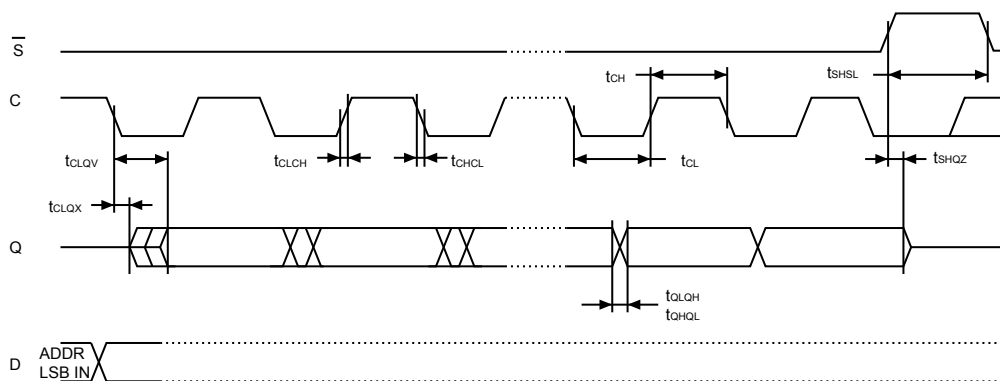


DT01447dV2

Figure 20. Hold timing



DT01448cV2


Figure 21. Serial output timing


DT014489V2



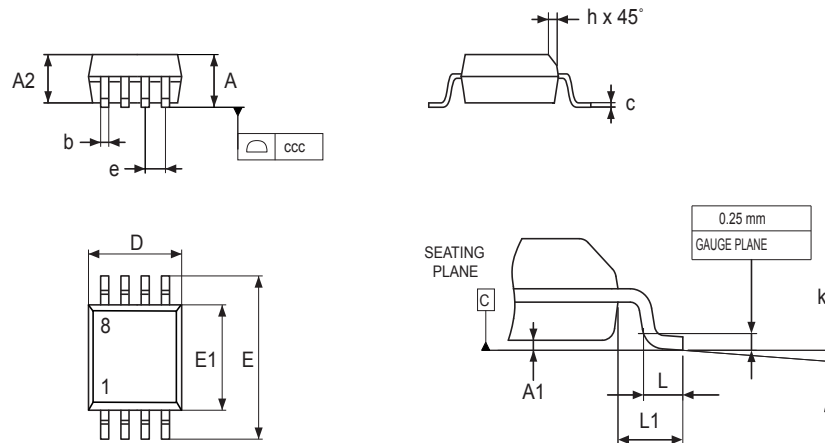
9 Package information

To meet environmental requirements, ST offers these devices in different grades of ECOPACK packages, depending on their level of environmental compliance. ECOPACK specifications, grade definitions, and product status are available at: www.st.com. ECOPACK is an ST trademark.

9.1 SO8N package information

This SO8N is an 8-lead, 4.9 x 6 mm, plastic small outline, 150 mils body width, package.

Figure 22. SO8N - Outline



1. Drawing is not to scale.

07_SO8_ME_V2

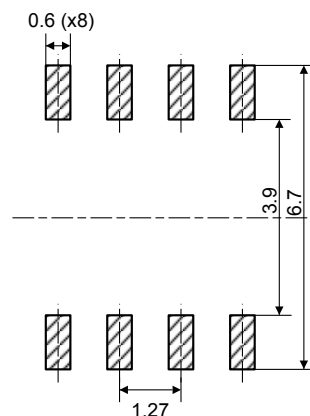
Table 14. SO8N - Mechanical data

Symbol	millimeters			inches ⁽¹⁾		
	Min.	Typ.	Max.	Min.	Typ.	Max.
A	-	-	1.750	-	-	0.0689
A1	0.100	-	0.250	0.0039	-	0.0098
A2	1.250	-	-	0.0492	-	-
b	0.280	-	0.480	0.0110	-	0.0189
c	0.170	-	0.230	0.0067	-	0.0091
D ⁽²⁾	4.800	4.900	5.000	0.1890	0.1929	0.1969
E	5.800	6.000	6.200	0.2283	0.2362	0.2441
E1 ⁽³⁾	3.800	3.900	4.000	0.1496	0.1535	0.1575
e	-	1.270	-	-	0.0500	-
h	0.250	-	0.500	0.0098	-	0.0197
k	0°	-	8°	0°	-	8°
L	0.400	-	1.270	0.0157	-	0.0500
L1	-	1.040	-	-	0.0409	-
ccc	-	-	0.100	-	-	0.0039

1. Values in inches are converted from mm and rounded to four decimal digits.
2. Dimension D does not include mold flash, protrusions, or gate burrs. Mold flash, protrusions, or gate burrs shall not exceed 0.15 mm per side.
3. Dimension E1 does not include interlead flash or protrusions. Interlead flash or protrusions shall not exceed 0.25 mm per side.

Note: The package top may be smaller than the package bottom. Dimensions D and E1 are determined at the outermost extremes of the plastic body exclusive of mold flash, tie bar burrs, gate burrs, and interleads flash, but including any mismatch between the top and bottom of the plastic body. The measurement side for mold flash, protrusions, or gate burrs is the bottom side.

Figure 23. SO8N - Footprint example



07_SO8N_FP_V2

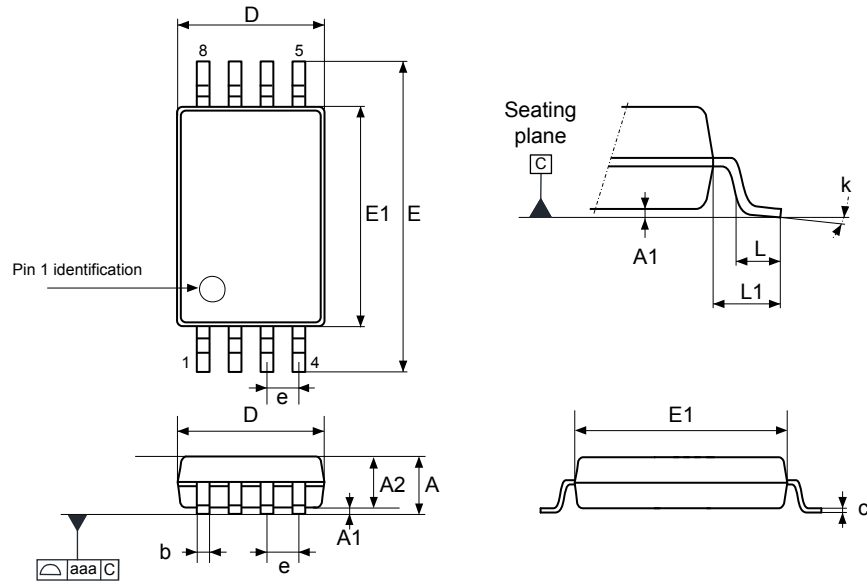
1. Dimensions are expressed in millimeters.



9.2 TSSOP8 package information

This TSSOP is an 8-lead, 3 x 6.4 mm, 0.65 mm pitch, thin shrink small outline package.

Figure 24. TSSOP8 – Outline



DT_6P_A_TSSOP8_ME_V4

1. Drawing is not to scale.

Table 15. TSSOP8 - Mechanical data

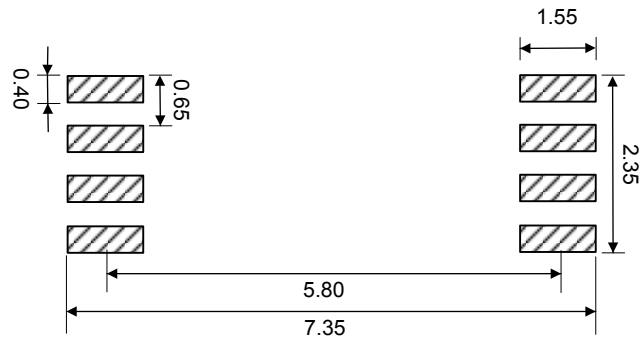
Symbol	millimeters			inches ⁽¹⁾		
	Min.	Typ.	Max.	Min.	Typ.	Max.
A	-	-	1.200	-	-	0.0472
A1	0.050	-	0.150	0.0020	-	0.0059
A2	0.800	1.000	1.050	0.0315	0.0394	0.0413
b	0.190	-	0.300	0.0075	-	0.0118
c	0.090	-	0.200	0.0035	-	0.0079
D ⁽²⁾	2.900	3.000	3.100	0.1142	0.1181	0.1220
e	-	0.650	-	-	0.0256	-
E	6.200	6.400	6.600	0.2441	0.2520	0.2598
E1 ⁽³⁾	4.300	4.400	4.500	0.1693	0.1732	0.1772
L	0.450	0.600	0.750	0.0177	0.0236	0.0295
L1	-	1.000	-	-	0.0394	-
k	0°	-	8°	0°	-	8°
aaa	-	-	0.100	-	-	0.0039

1. Values in inches are converted from mm and rounded to four decimal digits.
2. Dimension D does not include mold flash, protrusions, or gate burrs. Mold flash, protrusions, or gate burrs shall not exceed 0.15 mm per side.
3. Dimension E1 does not include interlead flash or protrusions. Interlead flash or protrusions shall not exceed 0.25 mm per side.



Note: The package top may be smaller than the package bottom. Dimensions *D* and *E1* are determined at the outermost extremes of the plastic body exclusive of the mold flash, tie bar burrs, gate burrs, and interleads flash, but including any mismatch between the top and bottom of the plastic body. The measurement side for the mold flash, protrusions, or gate burrs is the bottom side.

Figure 25. TSSOP8 – Footprint example



DT_6P_TSSOP8_FP_V2

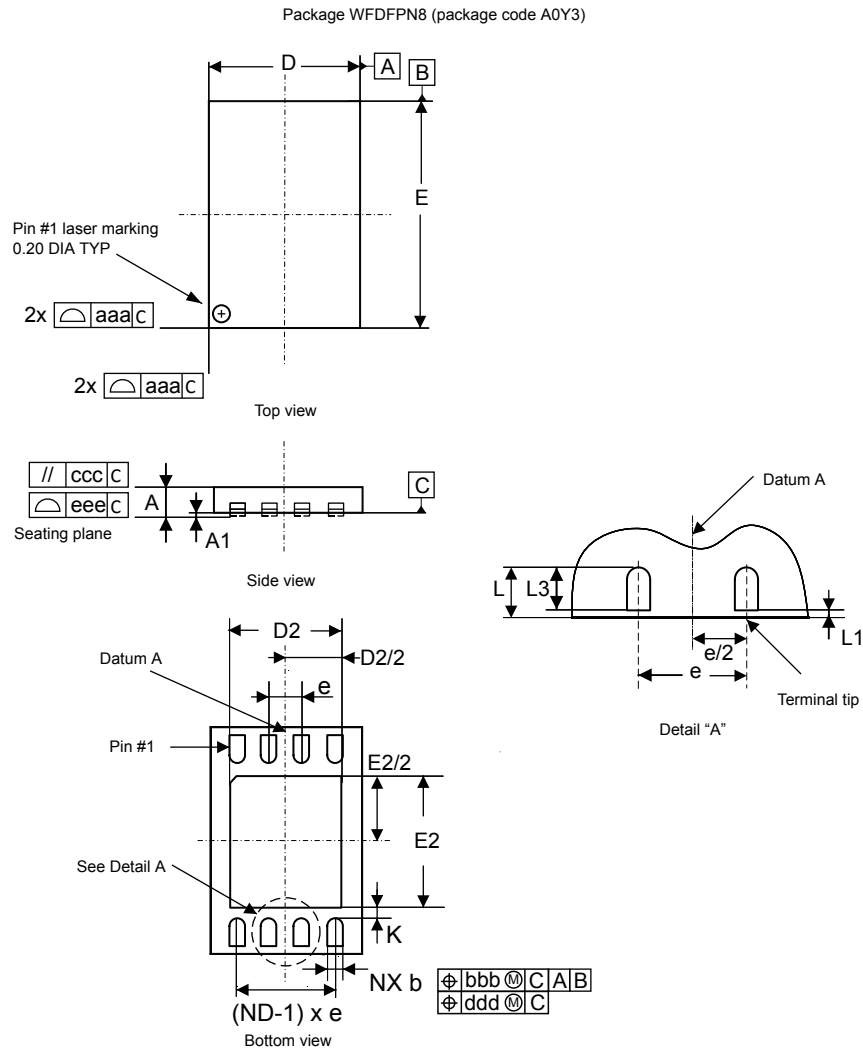
1. Dimensions are expressed in millimeters.



9.3 WFDFPN8 (DFN8) package information

This WFDFPN8 is a 8-lead, 2 x 3 mm, 0.5 mm pitch very very thin fine pitch dual flat package.

Figure 26. WFDFPN8 (DFN8) – Outline



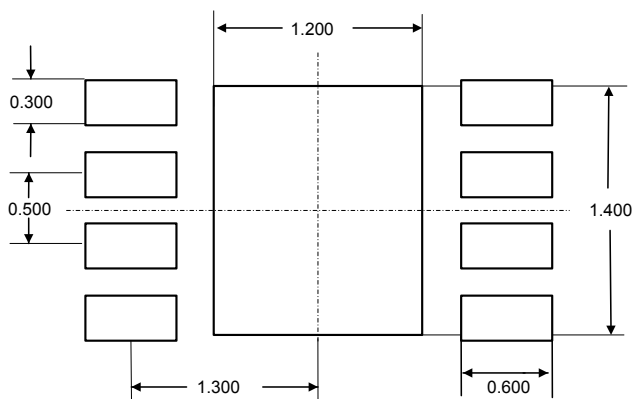
1. Drawing is not to scale.
2. Exposed copper is not systematic and can appear partially or totally according to the cross section.

Table 16. WFDFPN8 (DFN8) – Mechanical data

Symbol	millimeters			inches ⁽¹⁾		
	Min.	Typ.	Max.	Min.	Typ.	Max.
A	0.700	0.750	0.800	0.0276	0.0295	0.0315
A1	0.025	0.045	0.065	0.0010	0.0018	0.0026
b ⁽²⁾	0.200	0.250	0.300	0.0079	0.0098	0.0118
D	1.900	2.000	2.100	0.0748	0.0787	0.0827
E	2.900	3.000	3.100	0.1142	0.1181	0.1220
e	-	0.500	-	-	0.0197	-
L1	-	-	0.150	-	-	0.0059
L3	0.300	-	-	0.0118	-	-
D2	1.400	-	1.600	0.0551	-	0.0630
E2	1.200	-	1.400	0.0472	-	0.0551
K	0.400	-	-	0.0157	-	-
L	0.300	-	0.500	0.0118	-	0.0197
NX ⁽³⁾				8		
ND ⁽³⁾				4		
aaa	-	-	0.150	-	-	0.0059
bbb ⁽⁴⁾	-	-	0.100	-	-	0.0039
ccc	-	-	0.100	-	-	0.0039
ddd	-	-	0.050	-	-	0.0020
eee ⁽⁵⁾	-	-	0.080	-	-	0.0031

1. Values in inches are converted from mm and rounded to four decimal digits.
2. Dimension b applies to plated terminal and is measured between 0.15 and 0.30 mm from the terminal tip.
3. N is the number of terminals, ND is the number of terminals on "D" sides.
4. Max package warpage is 0.05 mm.
5. Applied for exposed die paddle and terminals. Exclude embedding part of exposed die paddle from measuring.

Figure 27. WFDFPN8 (DFN8) – Footprint example



Note: The central pad (the area E2 by D2 in the Figure 26) must be either connected to V_{SS} or left floating (not connected) in the end application.



10 Ordering information

Table 17. Ordering information scheme

Example:	M95	040-D	W	DW	4	T	P	/K
Device type								
M95 = SPI serial access EEPROM								
Device function								
040-D = 4-Kbit (512-byte) with additional identification page								
Operating voltage								
W = $V_{CC} = 2.5$ to 5.5 V								
R = $V_{CC} = 1.7$ to 5.5 V								
Package⁽¹⁾								
MN = SO8 (150 mil width)								
DW = TSSOP8 (169 mil width)								
MF = WDFPN8 (DFN8 2 x 3 mm)								
Device grade								
3 = Temperature range: -40 to 125 °C.								
4 = Temperature range: -40 to 145 °C.								
Option								
Blank = Tube packing								
T = Tape and reel packing								
Plating technology								
P or G = RoHS compliant and halogen-free (ECOPACK2)								
Process								
/K = Manufacturing technology CMOSF8H								

1. All packages are ECOPACK2 (RoHS-compliant and free of brominated, chlorinated and antimony-oxide flame retardants).

Note: For a list of available options (speed, package, etc.) or for further information on any aspect of this device, contact your nearest ST sales office.

Note: Parts marked as "ES" or "E" are not yet qualified and therefore not approved for use in production. ST is not responsible for any consequences resulting from such use. In no event will ST be liable for the customer using any of these engineering samples in production. ST's Quality department must be contacted prior to any decision to use these engineering samples to run a qualification activity.



Revision history

Table 18. Document revision history

Date	Revision	Changes
05-Apr-2013	1	Initial release.
05-Sep-2013	2	Added WFDFPN8 (MF) package. Removed UFDFPN8 (MLP8) package. Updated: – Section 4.4: Write Status Register (WRSR): replaced “Bits b7, b6, b5, b4 are always read as 0” by “Bits b7, b6, b5, b4 are always read as 1”. – Note (1) under Table 7: Absolute maximum ratings.
11-Dec-2013	3	Updated Figure 24: WFDFPN8 (MLP8) – 8-lead, 2 x 3 mm, 0.5 mm pitch very very thin fine pitch dual flat package outline. Document status changed from “Preliminary Data” to “Production Data”. Data retention modified from “40 years at 50 °C” to “50 years at 125 °C”.
26-Sept-2014	4	Updated Note 2 below Table 7: Absolute maximum ratings. Updated Table 13: DC characteristics (voltage range R, temperature range 3). Updated Table 17: WFPN8 (MLP8) – 8-lead, 2 x 3 mm, 0.5 mm pitch very very thin fine pitch dual flat package mechanical data. Updated Table 18: Ordering information scheme. Added Note 2 below Figure 24: WFDFPN8 (MLP8) – 8-lead, 2 x 3 mm, 0.5 mm pitch very very thin fine pitch dual flat package outline.
12-Jan-2015	5	Updated Table 17: WFPN8 (MLP8) – 8-lead, 2 x 3 mm, 0.5 mm pitch very very thin fine pitch dual flat package mechanical data Updated Figure 24: WFDFPN8 (MLP8) – 8-lead, 2 x 3 mm, 0.5 mm pitch very very thin fine pitch dual flat package outline Added paragraph: Engineering samples on page 39
16-Feb-2016	6	Updated – Section 9: Package mechanical data – VCC min value.
12-Dec-2024	7	Added: • 10Y longevity Updated: • Features • Figure 1. Logic diagram • Section 9.3: WFDFPN8 (DFN8) package information • Table 17. Ordering information scheme



Contents

1	Description	2
2	Signal description	4
2.1	Serial data output (Q)	4
2.2	Serial data input (D)	4
2.3	Serial clock (C)	4
2.4	Chip select (\overline{S})	4
2.5	Hold condition (\overline{HOLD})	4
2.6	Write protect (\overline{W})	4
2.7	V_{SS} ground	4
2.8	V_{CC} supply voltage	4
3	Operating features	5
3.1	Active power and standby power modes	5
3.2	SPI modes	5
3.3	Hold mode	6
3.4	Protocol control and data protection	6
3.4.1	Protocol control	6
3.4.2	Status register and data protection	7
3.5	Identification page	8
4	Instructions	9
4.1	Write enable (WREN)	10
4.2	Write disable (WRDI)	10
4.3	Read status register (RDSR)	11
4.4	Write status register (WRSR)	12
4.5	Read from memory array (READ)	13
4.6	Write to memory array (WRITE)	14
4.7	Read identification page (RDID)	16
4.8	Write identification page (WRID)	17
4.9	Read lock status (RDLS)	18
4.10	Lock identification page (LID)	18
5	Application design recommendations	20
5.1	Supply voltage (V_{CC})	20
5.1.1	Operating supply voltage (V_{CC})	20
5.1.2	Power-up conditions	20
5.1.3	Power-down	21



5.2	Implementing devices on SPI bus.....	21
5.3	ECC (error correction code).....	21
6	Delivery state.....	22
7	Absolute maximum ratings	23
8	DC and AC parameters	24
9	Package information.....	30
9.1	SO8N package information	30
9.2	TSSOP8 package information	32
9.3	WFDFPN8 (DFN8) package information	34
10	Ordering information	36
	Revision history	37



List of figures

Figure 1.	Logic diagram	2
Figure 2.	8-pin package connections	2
Figure 3.	Supported SPI modes	5
Figure 4.	Hold mode activation	6
Figure 5.	Status register format	7
Figure 6.	Write enable (WREN) sequence	10
Figure 7.	Write disable (WRDI) sequence	10
Figure 8.	Read status register (RDSR) sequence	11
Figure 9.	Write status register (WRSR) sequence	12
Figure 10.	Read from memory array (READ) sequence	13
Figure 11.	Byte write (WRITE) sequence	14
Figure 12.	Page write (WRITE) sequence	15
Figure 13.	Read identification page sequence	16
Figure 14.	Write identification page sequence	17
Figure 15.	Read lock status sequence	18
Figure 16.	Lock ID sequence	19
Figure 17.	Bus controller and memory devices on the SPI bus	21
Figure 18.	AC measurement I/O waveform	28
Figure 19.	Serial input timing	28
Figure 20.	Hold timing	28
Figure 21.	Serial output timing	29
Figure 22.	SO8N - Outline	30
Figure 23.	SO8N - Footprint example	31
Figure 24.	TSSOP8 – Outline	32
Figure 25.	TSSOP8 – Footprint example	33
Figure 26.	WFDFPN8 (DFN8) – Outline	34
Figure 27.	WFDFPN8 (DFN8) – Footprint example	35



List of tables

Table 1.	Signal names	3
Table 2.	Write-protected block size	8
Table 3.	Device identification bytes	8
Table 4.	Instruction set	9
Table 5.	Significant bits within the address byte	9
Table 6.	Absolute maximum ratings	23
Table 7.	Cycling performance by byte	24
Table 8.	Operating conditions (voltage range W, temperature range 4)	24
Table 9.	Operating conditions (voltage range R, temperature range 3)	24
Table 10.	Operating conditions (voltage range R, temperature range 3) for high-speed communications	24
Table 11.	DC characteristics (voltage range W, temperature range 4)	25
Table 12.	DC characteristics (voltage range R, temperature range 3)	26
Table 13.	AC characteristics	27
Table 14.	SO8N - Mechanical data	31
Table 15.	TSSOP8 - Mechanical data	32
Table 16.	WFDFPN8 (DFN8) – Mechanical data	35
Table 17.	Ordering information scheme	36
Table 18.	Document revision history	37

**IMPORTANT NOTICE – READ CAREFULLY**

STMicroelectronics NV and its subsidiaries (“ST”) reserve the right to make changes, corrections, enhancements, modifications, and improvements to ST products and/or to this document at any time without notice. Purchasers should obtain the latest relevant information on ST products before placing orders. ST products are sold pursuant to ST’s terms and conditions of sale in place at the time of order acknowledgment.

Purchasers are solely responsible for the choice, selection, and use of ST products and ST assumes no liability for application assistance or the design of purchasers’ products.

No license, express or implied, to any intellectual property right is granted by ST herein.

Resale of ST products with provisions different from the information set forth herein shall void any warranty granted by ST for such product.

ST and the ST logo are trademarks of ST. For additional information about ST trademarks, refer to www.st.com/trademarks. All other product or service names are the property of their respective owners.

Information in this document supersedes and replaces information previously supplied in any prior versions of this document.

© 2024 STMicroelectronics – All rights reserved

OUR CERTIFICATE

DiGi provide top-quality products and perfect service for customer worldwide through standardization, technological innovation and continuous improvement. DiGi through third-party certification, we stricly control the quality of products and services. Welcome your RFQ to

Email: Info@DiGi-Electronics.com



Tel: +00 852-30501935

RFQ Email: Info@DiGi-Electronics.com

DiGi is a global authorized distributor of electronic components.