

STB14NK60ZT4 Datasheet

www.digi-electronics.com

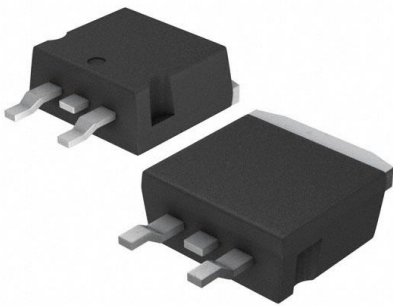

<https://www.DiGi-Electronics.com>

DiGi Electronics Part Number	STB14NK60ZT4-DG
Manufacturer	STMicroelectronics
Manufacturer Product Number	STB14NK60ZT4
Description	MOSFET N-CH 600V 13.5A D2PAK
Detailed Description	N-Channel 600 V 13.5A (Tc) 160W (Tc) Surface Mount D2PAK

This model STB14NK60ZT4 is available at DiGi Electronics.

DiGi Electronics offers a global database of semiconductor and electronic component datasheets.

We welcome your inquiries regarding pricing, lead time, or other product-related questions.

 [Request a Quote](#)

 [Datasheet Search](#)



Tel: +00 852-30501935

RFQ Email: Info@DiGi-Electronics.com

DiGi is a global authorized distributor of electronic components.

Purchase and inquiry

Manufacturer Product Number:

STB14NK60ZT4

Series:

SuperMESH™

FET Type:

N-Channel

Drain to Source Voltage (Vdss):

600 V

Drive Voltage (Max Rds On, Min Rds On):

10V

Vgs(th) (Max) @ Id:

4.5V @ 100µA

Vgs (Max):

±30V

FET Feature:

-

Operating Temperature:

-55°C ~ 150°C (Tj)

Supplier Device Package:

D2PAK

Base Product Number:

STB14

Manufacturer:

STMicroelectronics

Product Status:

Active

Technology:

MOSFET (Metal Oxide)

Current - Continuous Drain (Id) @ 25°C:

13.5A (Tc)

Rds On (Max) @ Id, Vgs:

500mOhm @ 6A, 10V

Gate Charge (Qg) (Max) @ Vgs:

75 nC @ 10 V

Input Capacitance (Ciss) (Max) @ Vds:

2220 pF @ 25 V

Power Dissipation (Max):

160W (Tc)

Mounting Type:

Surface Mount

Package / Case:

TO-263-3, D2PAK (2 Leads + Tab), TO-263AB

Environmental & Export classification

RoHS Status:

ROHS3 Compliant

REACH Status:

REACH Unaffected

HTSUS:

8541.29.0095

Moisture Sensitivity Level (MSL):

1 (Unlimited)

ECCN:

EAR99



STB14NK60ZT4, STP14NK60ZFP

N-channel 600 V, 0.45 Ω typ., 13.5 A SuperMESH™
Power MOSFETs in D²PAK and TO-220FP packages

Datasheet - production data

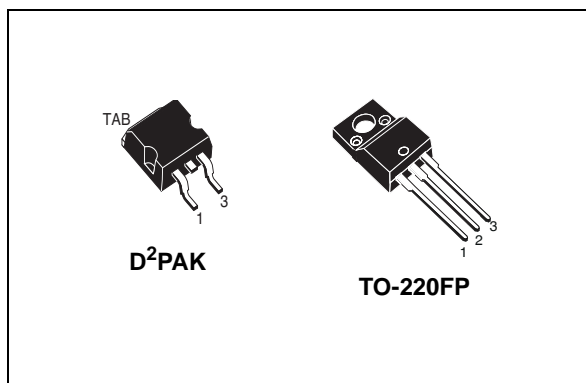
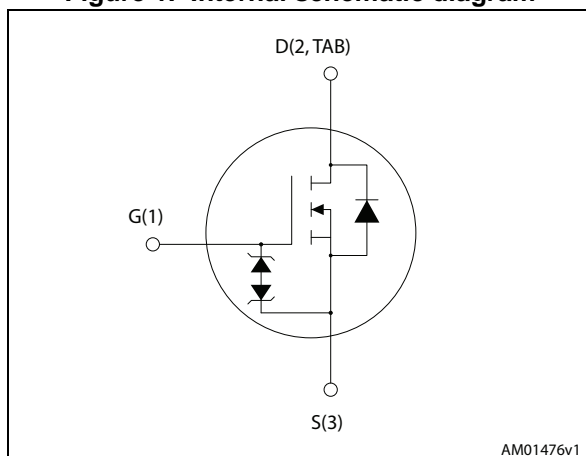

Figure 1. Internal schematic diagram



Features

Order codes	V _{DS}	R _{DS(on)} max.	I _D	P _{TOT}
STB14NK60ZT4	600 V	0.5 Ω	13.5 A	160 W
STP14NK60ZFP				40 W

- Extremely high dv/dt capability
- 100% avalanche tested
- Gate charge minimized
- Very low intrinsic capacitances
- Very good manufacturing repeatability
- Zener-protected

Applications

- Switching applications

Description

These devices are N-channel Zener-protected Power MOSFETs developed using STMicroelectronics' SuperMESH™ technology, achieved through optimization of ST's well established strip-based PowerMESH™ layout. In addition to a significant reduction in on-resistance, this device is designed to ensure a high level of dv/dt capability for the most demanding applications.

Table 1. Device summary

Order codes	Marking	Package	Packaging
STB14NK60ZT4	B14NK60Z	D ² PAK	Tape and reel
STP14NK60ZFP	P14NK60ZFP	TO-220FP	Tube

Contents

1	Electrical ratings	3
2	Electrical characteristics	4
2.1	Electrical characteristics (curves)	6
3	Test circuits	9
4	Package mechanical data	10
4.1	D ² PAK, STB14NK60ZT4	11
4.2	TO-220FP, STP14NK60ZFP	14
5	Packaging mechanical data	16
6	Revision history	18

1 Electrical ratings

Table 2. Absolute maximum ratings

Symbol	Parameter	Value		Unit
		D ² PAK	TO-220FP	
V _{DS}	Drain-source voltage	600		V
V _{DGR}	Drain-gate voltage (R _{GS} = 20 kΩ)	600		V
V _{GS}	Gate-source voltage	± 30		V
I _D	Drain current (continuous) at T _C = 25°C	13.5	13.5 ⁽¹⁾	A
I _D	Drain current (continuous) at T _C =100°C	8.5	8.5 ⁽¹⁾	A
I _{DM} ⁽²⁾	Drain current (pulsed)	54	54 ⁽¹⁾	A
P _{TOT}	Total dissipation at T _C = 25°C	160	40	W
	Derating factor	1.28	0.32	W/°C
ESD	Gate-source human body model (R= 1.5 kΩ, C= 100pF)	4		kV
dv/dt ⁽³⁾	Peak diode recovery voltage slope	4.5		V/ns
V _{ISO}	Insulation withstand voltage (RMS) from all three leads to external heat sink (t = 1 s, T _C = 25 °C)		2500	V
T _J T _{stg}	Operating junction temperature Storage temperature	-55 to 150		°C

- Limited by maximum junction temperature
- Pulse width limited by safe operating area
- I_{SD} ≤ 13.5A, di/dt ≤ 200A/μs, V_{DD} ≤ V_{(BR)DSS}, T_J ≤ T_{JMAX}.

Table 3. Thermal data

Symbol	Parameter	Value		Unit
		D ² PAK	TO-220FP	
R _{thj-case}	Thermal resistance junction-case max	0.78	3.1	°C/W
R _{thj-amb}	Thermal resistance junction-ambient max	62.5	62.5	°C/W

Table 4. Avalanche characteristics

Symbol	Parameter	Value	Unit
I _{AS}	Avalanche current, repetitive or not-repetitive (pulse width limited by T _{Jmax})	12	A
E _{AS}	Single pulse avalanche energy (starting T _J =25°C, I _D =I _{AR} , V _{dd} =50 V)	300	mJ

2 Electrical characteristics

($T_{CASE}=25^{\circ}C$ unless otherwise specified)

Table 5. On/off states

Symbol	Parameter	Test conditions	Min.	Typ.	Max.	Unit
$V_{(BR)DSS}$	Drain-source breakdown voltage	$I_D = 1 \text{ mA}, V_{GS} = 0$	600			V
I_{DSS}	Zero gate voltage drain current ($V_{GS} = 0$)	$V_{DS} = 600 \text{ V}$			1	μA
		$V_{DS} = 600 \text{ V}, T_C = 125^{\circ}C$			50	μA
I_{GSS}	Gate body leakage current ($V_{DS} = 0$)	$V_{GS} = \pm 30 \text{ V}$			± 10	μA
$V_{GS(th)}$	Gate threshold voltage	$V_{DS} = V_{GS}, I_D = 100 \mu\text{A}$	3	3.75	4.5	V
$R_{DS(on)}$	Static drain-source on resistance	$V_{GS} = 10 \text{ V}, I_D = 6 \text{ A}$		0.45	0.5	Ω

Table 6. Dynamic

Symbol	Parameter	Test conditions	Min.	Typ.	Max.	Unit
C_{iss}	Input capacitance	$V_{DS} = 25\text{V}, f = 1 \text{ MHz}, V_{GS} = 0$	-	2220	-	pF
C_{oss}	Output capacitance		-	240	-	pF
C_{rss}	Reverse transfer capacitance		-	57	-	pF
$C_{oss \text{ eq}}^{(1)}$	Equivalent output capacitance	$V_{GS} = 0, V_{DS} = 0 \text{ V to } 480 \text{ V}$	-	122	-	pF
Q_g	Total gate charge	$V_{DD} = 480 \text{ V}, I_D = 12 \text{ A}, V_{GS} = 10 \text{ V}$	-	75	-	nC
Q_{gs}	Gate-source charge		-	13.2	-	nC
Q_{gd}	Gate-drain charge		-	38.6	-	nC

1. $C_{oss \text{ eq}}$ is defined as a constant equivalent capacitance giving the same charging time as C_{oss} when V_{DS} increases from 0 to 80% V_{DSS}

Table 7. Switching times

Symbol	Parameter	Test conditions	Min.	Typ.	Max.	Unit
$t_{d(on)}$	Turn-on delay time	$V_{DD}=300\text{ V}$, $I_D=6\text{ A}$, $R_G=4.7\ \Omega$, $V_{GS}=10\text{ V}$ (see Figure 17)	-	26	-	ns
t_r	Rise time		-	18	-	ns
$t_{d(off)}$	Turn-off delay time		-	62	-	ns
t_f	Fall time		-	13	-	ns
$t_{r(Voff)}$	Off-voltage rise time	$V_{DD}=480\text{ V}$, $I_D=12\text{ A}$, $R_G=4.7\ \Omega$, $V_{GS}=10\text{ V}$ (see Figure 19)	-	12	-	ns
t_f	Fall time		-	9.5	-	ns
t_c	Cross-over time		-	22	-	ns

Table 8. Source drain diode

Symbol	Parameter	Test conditions	Min	Typ.	Max	Unit
I_{SD}	Source-drain current		-		12	A
$I_{SDM}^{(1)}$	Source-drain current (pulsed)		-		48	A
$V_{SD}^{(2)}$	Forward on voltage	$I_{SD}=12\text{ A}$, $V_{GS}=0$	-		1.6	V
t_{rr}	Reverse recovery time	$I_{SD}=12\text{ A}$, $di/dt = 100\text{ A}/\mu\text{s}$, $V_{DD}=50\text{ V}$	-	490		ns
Q_{rr}	Reverse recovery charge		-	4.7		μC
I_{RRM}	Reverse recovery current		-	19.3		A
t_{rr}	Reverse recovery time	$I_{SD}=12\text{ A}$, $di/dt = 100\text{ A}/\mu\text{s}$, $V_{DD}=50\text{ V}$, $T_j=150\text{ }^\circ\text{C}$	-	664		ns
Q_{rr}	Reverse recovery charge		-	6.8		μC
I_{RRM}	Reverse recovery current		-	20.5		A

1. Pulse width limited by safe operating area

2. Pulsed: pulse duration=300 μs , duty cycle 1.5%

Table 9. Gate-source Zener diode

Symbol	Parameter	Test conditions	Min	Typ.	Max.	Unit
$V_{(BR)GSO}$	Gate-source breakdown voltage	$I_{GS} = \pm 1\text{ mA}$, $I_D=0$	30	-	-	V

The built-in back-to-back Zener diodes have specifically been designed to enhance the device's ESD capability. In this respect the Zener voltage is appropriate to achieve an efficient and cost-effective intervention to protect the device's integrity. These integrated Zener diodes thus avoid the usage of external components.

2.1 Electrical characteristics (curves)

Figure 2. Safe operating area for D²PAK

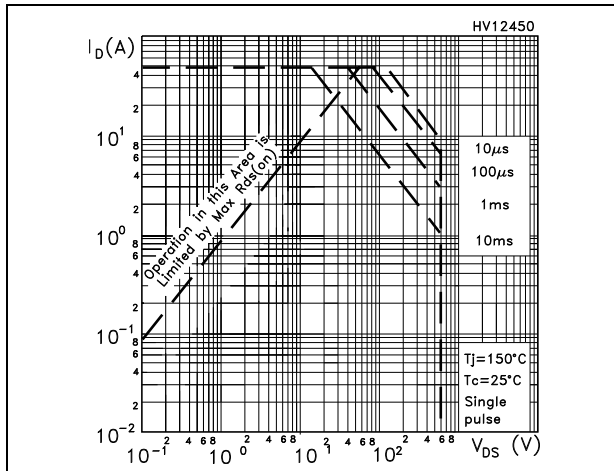

Figure 3. Thermal impedance for D²PAK

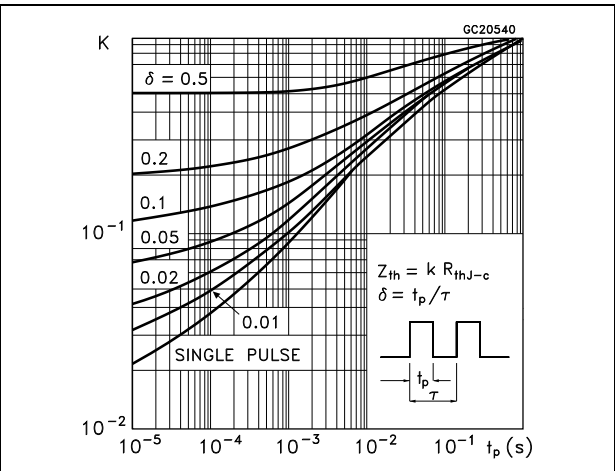

Figure 4. Safe operating area for TO-220FP

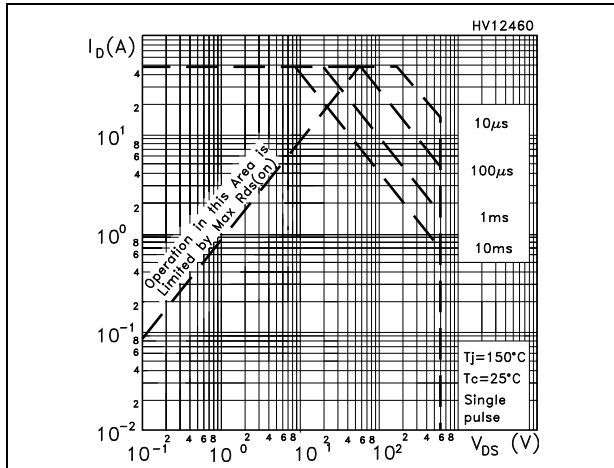

Figure 5. Thermal impedance for TO-220FP

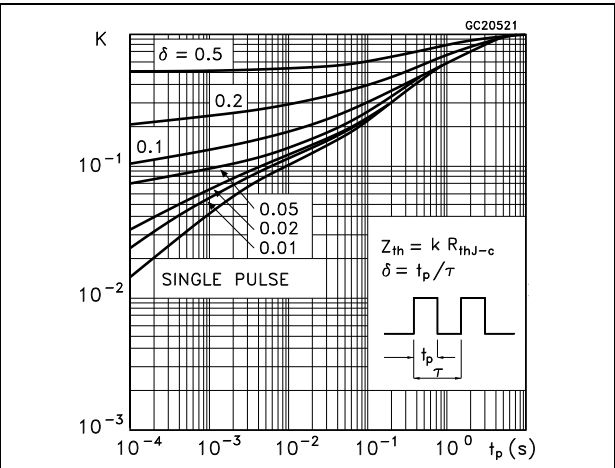

Figure 6. Output characteristics

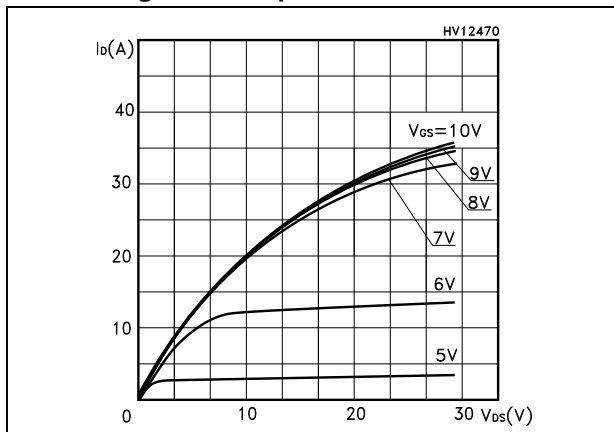
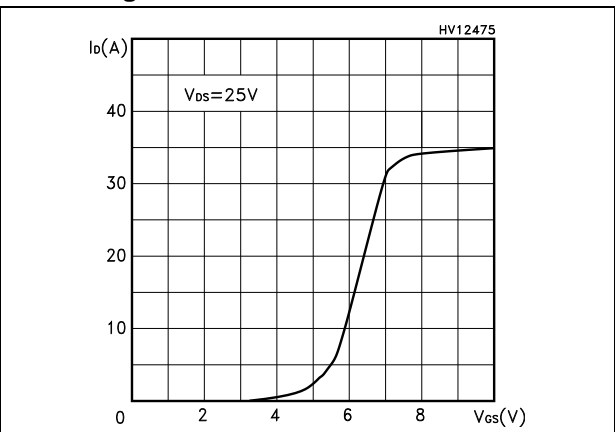

Figure 7. Transfer characteristics



STB14NK60ZT4, STP14NK60ZFP

Electrical characteristics

Figure 8. Transconductance

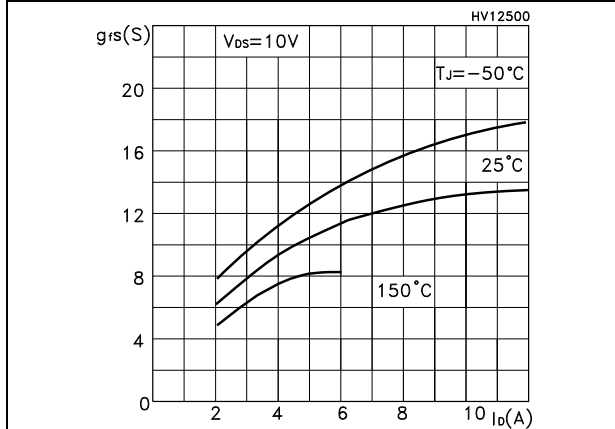

Figure 9. Static drain-source on-resistance

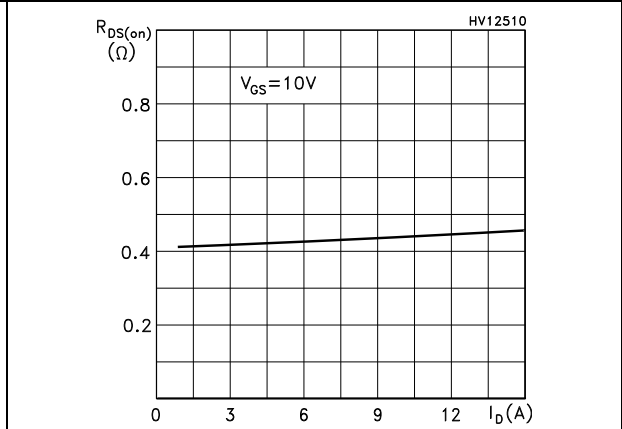

Figure 10. Gate charge vs gate-source voltage

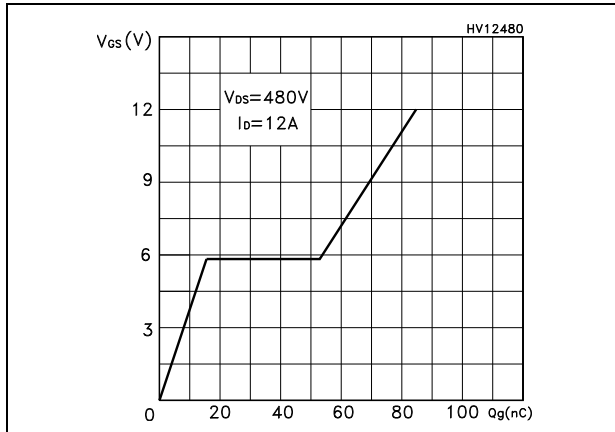

Figure 11. Capacitance variations

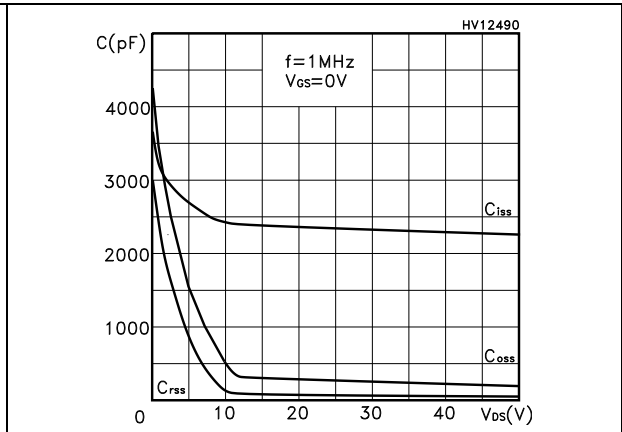

Figure 12. Normalized gate threshold voltage vs temperature

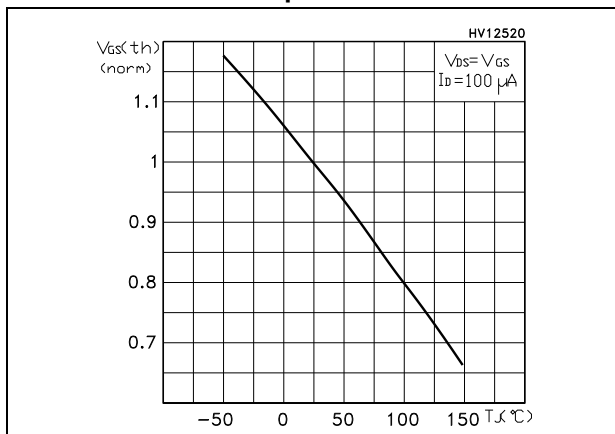
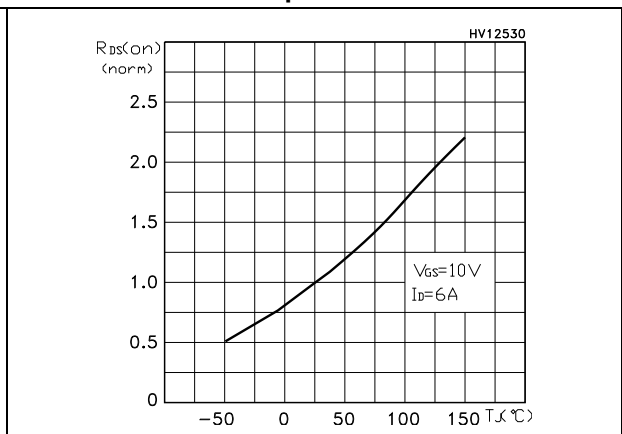

Figure 13. Normalized on-resistance vs temperature



Electrical characteristics

STB14NK60ZT4, STP14NK60ZFP

Figure 14. Source-drain diode forward characteristics

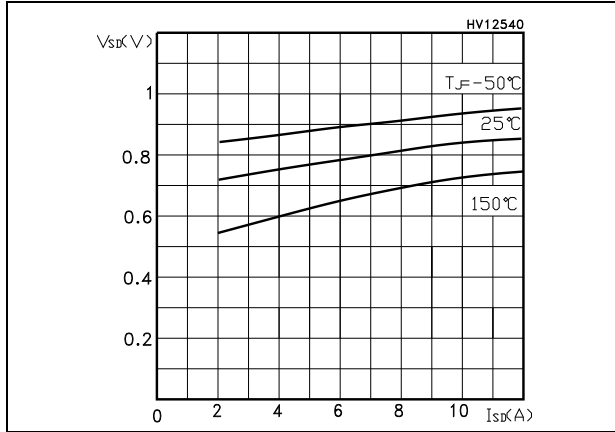

Figure 15. Normalized $V_{(BR)DSS}$ vs temperature

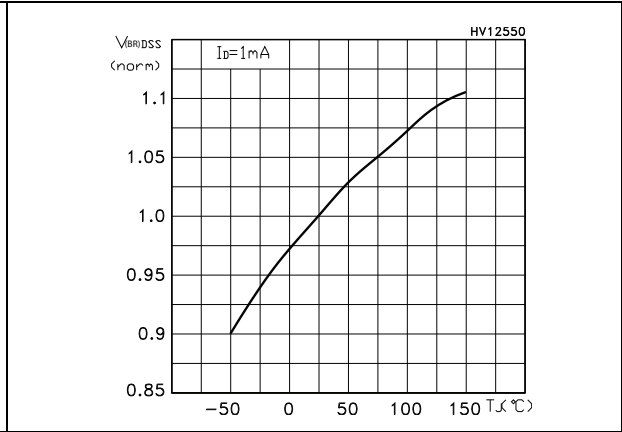
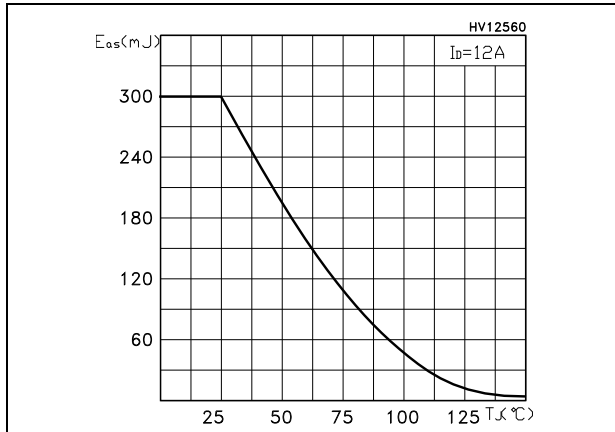

Figure 16. Maximum avalanche energy vs temperature



3 Test circuits

Figure 17. Switching times test circuit for resistive load

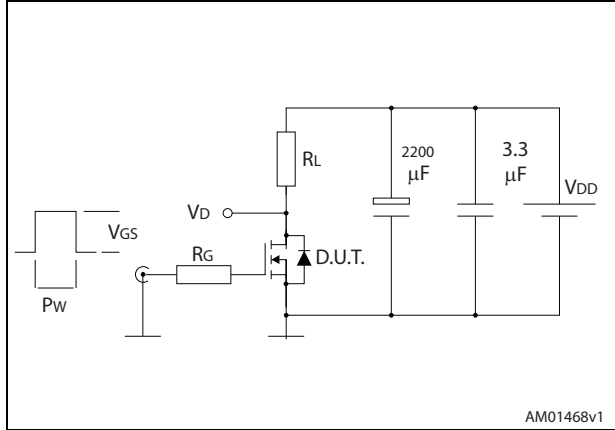

Figure 18. Gate charge test circuit

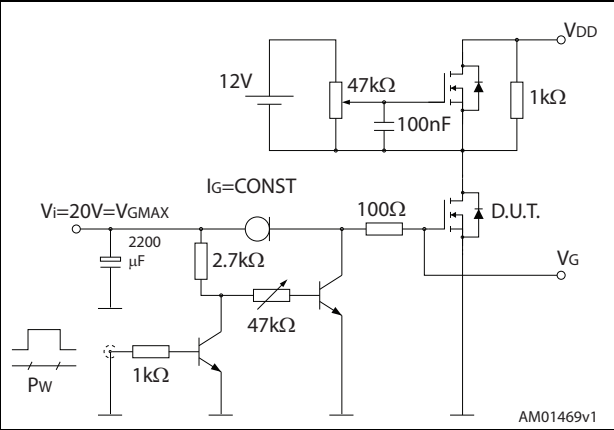

Figure 19. Test circuit for inductive load switching and diode recovery times

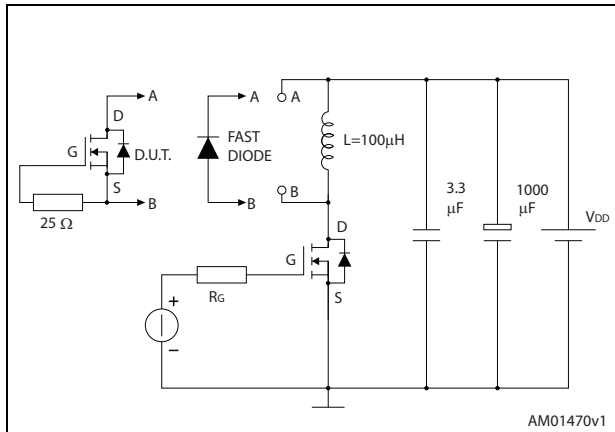

Figure 20. Unclamped inductive load test circuit

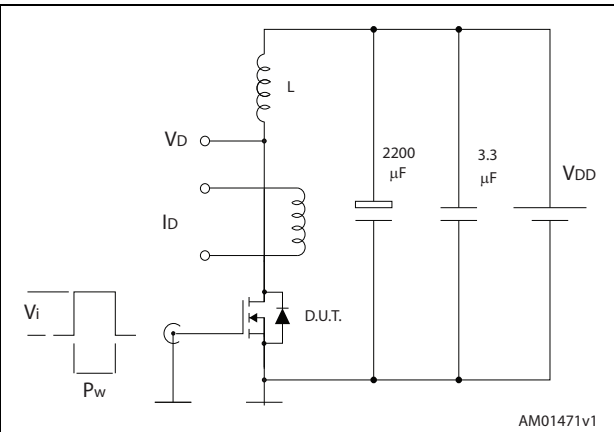

Figure 21. Unclamped inductive waveform

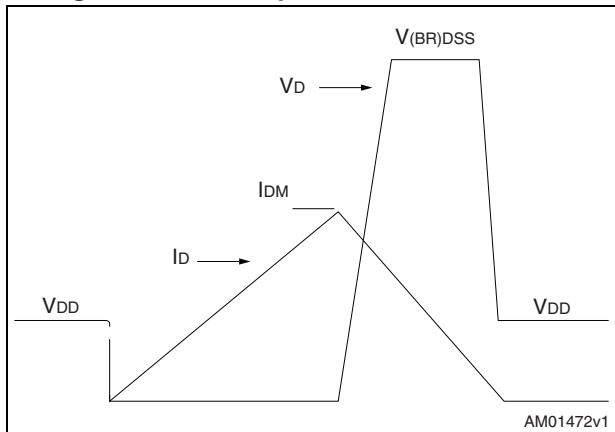
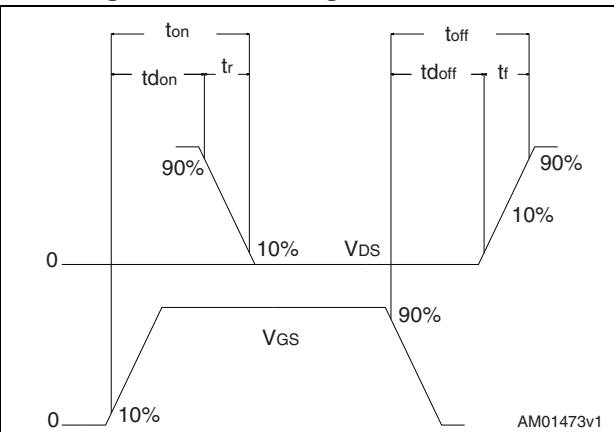

Figure 22. Switching time waveform



4 Package mechanical data

In order to meet environmental requirements, ST offers these devices in different grades of ECOPACK[®] packages, depending on their level of environmental compliance. ECOPACK[®] specifications, grade definitions and product status are available at: www.st.com. ECOPACK[®] is an ST trademark.

4.1 D²PAK, STB14NK60ZT4Figure 23. D²PAK (TO-263) drawing

Table 10. D²PAK (TO-263) mechanical data

Dim.	mm		
	Min.	Typ.	Max.
A	4.40		4.60
A1	0.03		0.23
b	0.70		0.93
b2	1.14		1.70
c	0.45		0.60
c2	1.23		1.36
D	8.95		9.35
D1	7.50		
E	10		10.40
E1	8.50		
e		2.54	
e1	4.88		5.28
H	15		15.85
J1	2.49		2.69
L	2.29		2.79
L1	1.27		1.40
L2	1.30		1.75
R		0.4	
V2	0°		8°

Figure 24. D²PAK footprint^(a)

a. All dimension are in millimeters

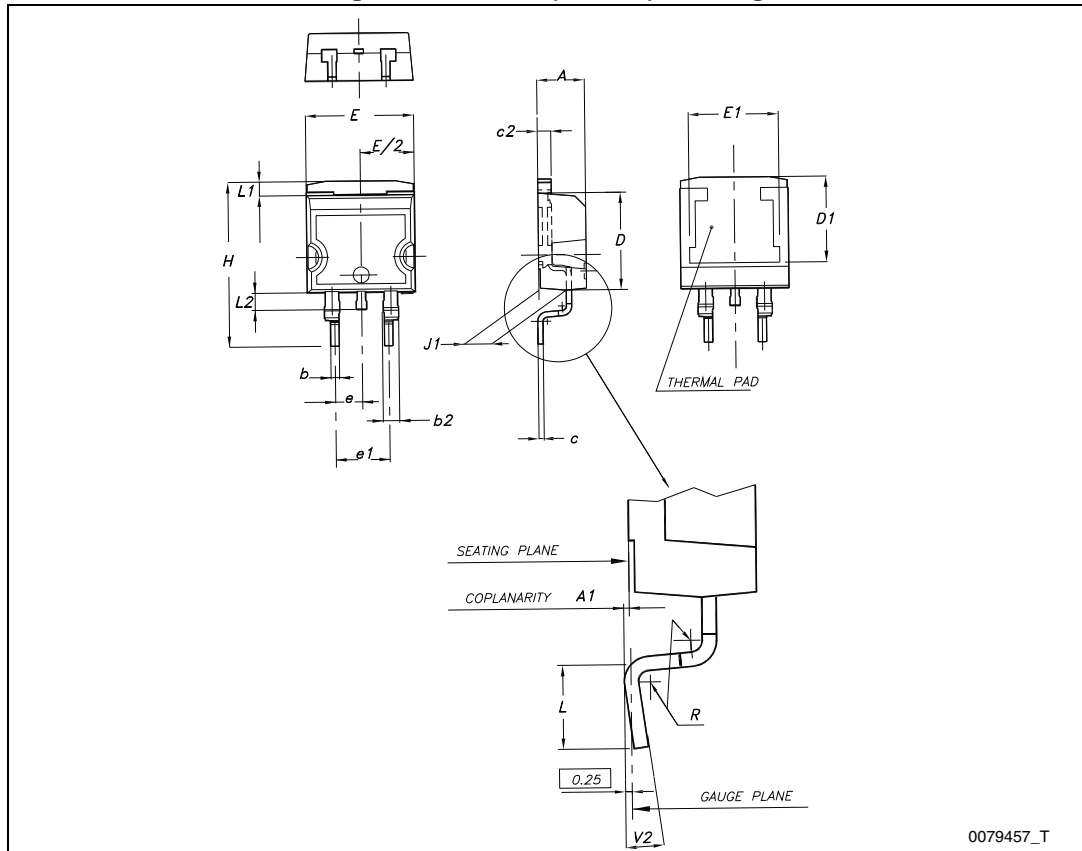
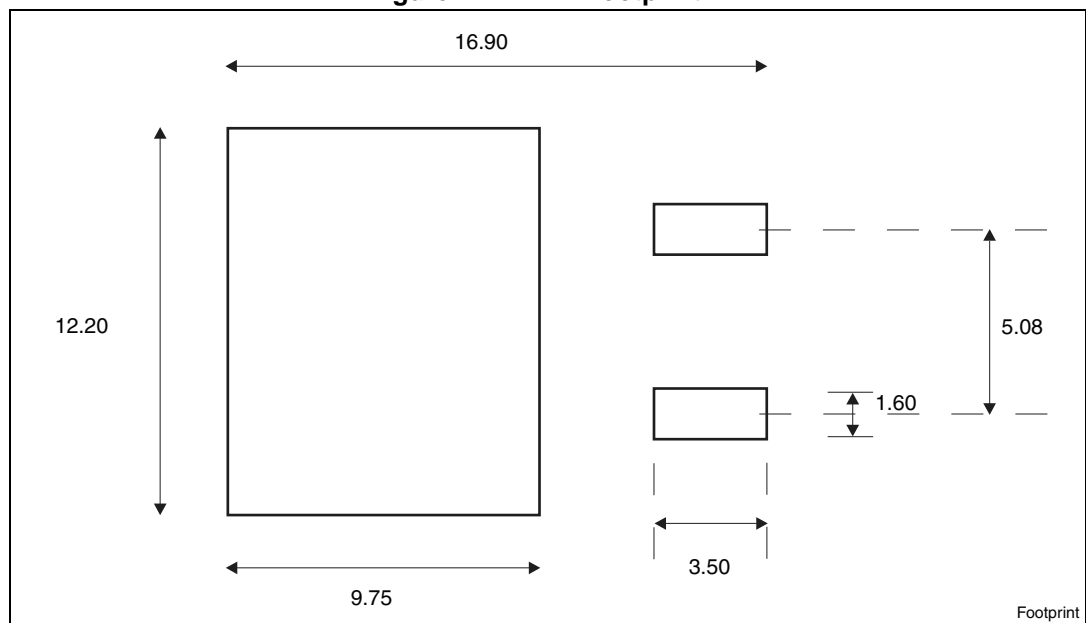
4.2 TO-220FP, STP14NK60ZFP

Figure 25. TO-220FP drawing

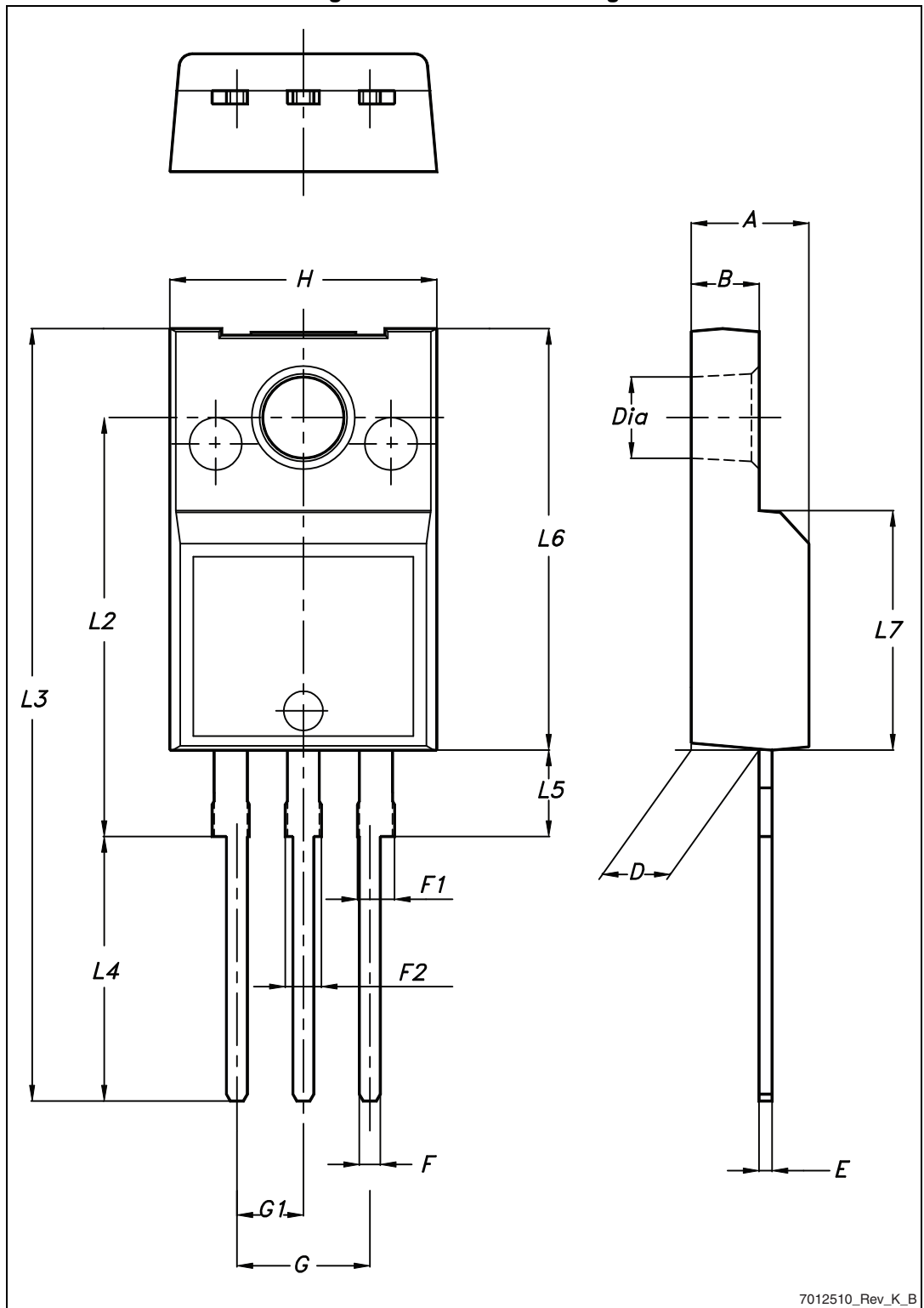

Table 11. TO-220FP mechanical data

Dim.	mm		
	Min.	Typ.	Max.
A	4.4		4.6
B	2.5		2.7
D	2.5		2.75
E	0.45		0.7
F	0.75		1
F1	1.15		1.70
F2	1.15		1.70
G	4.95		5.2
G1	2.4		2.7
H	10		10.4
L2		16	
L3	28.6		30.6
L4	9.8		10.6
L5	2.9		3.6
L6	15.9		16.4
L7	9		9.3
Ø	3		3.2

5 Packaging mechanical data

Figure 26. Tape

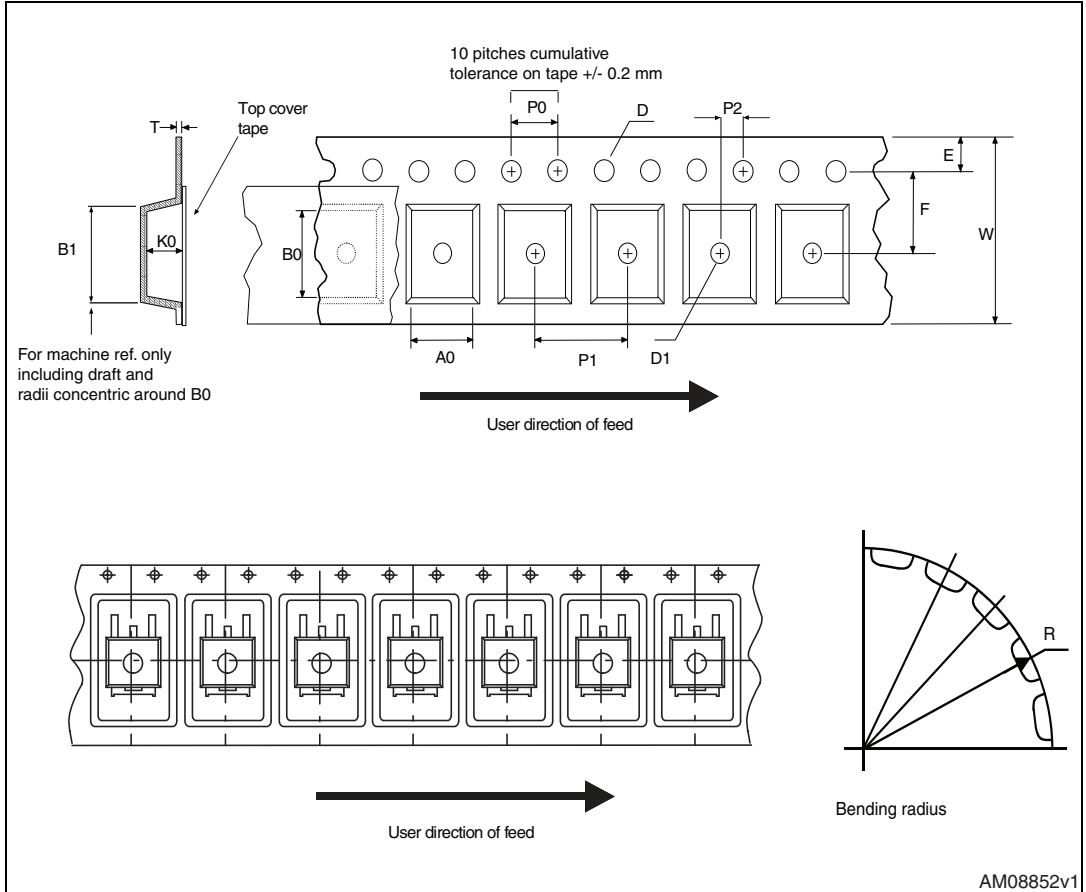
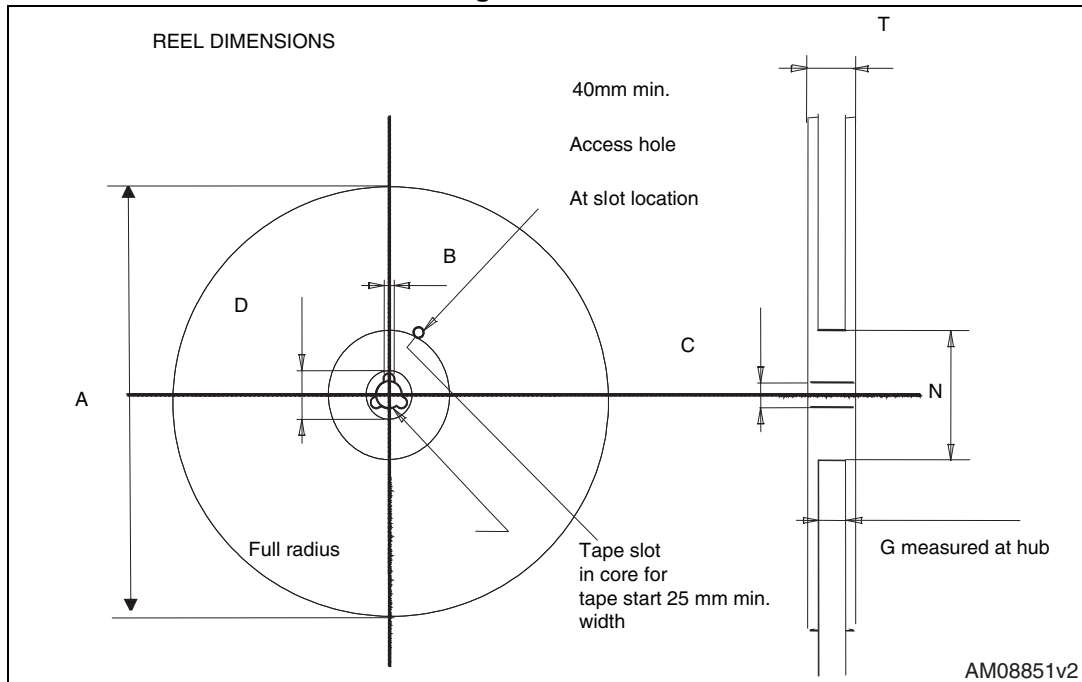

Figure 27. Reel

Table 12. D²PAK (TO-263) tape and reel mechanical data

Tape			Reel		
Dim.	mm		Dim.	mm	
	Min.	Max.		Min.	Max.
A0	10.5	10.7	A		330
B0	15.7	15.9	B	1.5	
D	1.5	1.6	C	12.8	13.2
D1	1.59	1.61	D	20.2	
E	1.65	1.85	G	24.4	26.4
F	11.4	11.6	N	100	
K0	4.8	5.0	T		30.4
P0	3.9	4.1			
P1	11.9	12.1	Base qty		1000
P2	1.9	2.1	Bulk qty		1000
R	50				
T	0.25	0.35			
W	23.7	24.3			

6 Revision history

Table 13. Document revision history

Date	Revision	Changes
06-May-2014	1	Initial release. Part numbers previously included in datasheet DocID8984

STB14NK60ZT4, STP14NK60ZFP

Please Read Carefully:

Information in this document is provided solely in connection with ST products. STMicroelectronics NV and its subsidiaries ("ST") reserve the right to make changes, corrections, modifications or improvements, to this document, and the products and services described herein at any time, without notice.

All ST products are sold pursuant to ST's terms and conditions of sale.

Purchasers are solely responsible for the choice, selection and use of the ST products and services described herein, and ST assumes no liability whatsoever relating to the choice, selection or use of the ST products and services described herein.

No license, express or implied, by estoppel or otherwise, to any intellectual property rights is granted under this document. If any part of this document refers to any third party products or services it shall not be deemed a license grant by ST for the use of such third party products or services, or any intellectual property contained therein or considered as a warranty covering the use in any manner whatsoever of such third party products or services or any intellectual property contained therein.

UNLESS OTHERWISE SET FORTH IN ST'S TERMS AND CONDITIONS OF SALE ST DISCLAIMS ANY EXPRESS OR IMPLIED WARRANTY WITH RESPECT TO THE USE AND/OR SALE OF ST PRODUCTS INCLUDING WITHOUT LIMITATION IMPLIED WARRANTIES OF MERCHANTABILITY, FITNESS FOR A PARTICULAR PURPOSE (AND THEIR EQUIVALENTS UNDER THE LAWS OF ANY JURISDICTION), OR INFRINGEMENT OF ANY PATENT, COPYRIGHT OR OTHER INTELLECTUAL PROPERTY RIGHT.

ST PRODUCTS ARE NOT DESIGNED OR AUTHORIZED FOR USE IN: (A) SAFETY CRITICAL APPLICATIONS SUCH AS LIFE SUPPORTING, ACTIVE IMPLANTED DEVICES OR SYSTEMS WITH PRODUCT FUNCTIONAL SAFETY REQUIREMENTS; (B) AERONAUTIC APPLICATIONS; (C) AUTOMOTIVE APPLICATIONS OR ENVIRONMENTS, AND/OR (D) AEROSPACE APPLICATIONS OR ENVIRONMENTS. WHERE ST PRODUCTS ARE NOT DESIGNED FOR SUCH USE, THE PURCHASER SHALL USE PRODUCTS AT PURCHASER'S SOLE RISK, EVEN IF ST HAS BEEN INFORMED IN WRITING OF SUCH USAGE, UNLESS A PRODUCT IS EXPRESSLY DESIGNATED BY ST AS BEING INTENDED FOR "AUTOMOTIVE, AUTOMOTIVE SAFETY OR MEDICAL" INDUSTRY DOMAINS ACCORDING TO ST PRODUCT DESIGN SPECIFICATIONS. PRODUCTS FORMALLY ESCC, QML OR JAN QUALIFIED ARE DEEMED SUITABLE FOR USE IN AEROSPACE BY THE CORRESPONDING GOVERNMENTAL AGENCY.

Resale of ST products with provisions different from the statements and/or technical features set forth in this document shall immediately void any warranty granted by ST for the ST product or service described herein and shall not create or extend in any manner whatsoever, any liability of ST.

ST and the ST logo are trademarks or registered trademarks of ST in various countries.

Information in this document supersedes and replaces all information previously supplied.

The ST logo is a registered trademark of STMicroelectronics. All other names are the property of their respective owners.

© 2014 STMicroelectronics - All rights reserved

STMicroelectronics group of companies

Australia - Belgium - Brazil - Canada - China - Czech Republic - Finland - France - Germany - Hong Kong - India - Israel - Italy - Japan - Malaysia - Malta - Morocco - Philippines - Singapore - Spain - Sweden - Switzerland - United Kingdom - United States of America

www.st.com



OUR CERTIFICATE

DiGi provide top-quality products and perfect service for customer worldwide through standardization, technological innovation and continuous improvement. DiGi through third-party certification, we stricly control the quality of products and services. Welcome your RFQ to

Email: Info@DiGi-Electronics.com



Tel: +00 852-30501935

RFQ Email: Info@DiGi-Electronics.com

DiGi is a global authorized distributor of electronic components.