

STD16NF06T4 Datasheet



<https://www.DiGi-Electronics.com>

DiGi Electronics Part Number	STD16NF06T4-DG
Manufacturer	STMicroelectronics
Manufacturer Product Number	STD16NF06T4
Description	MOSFET N-CH 60V 16A DPAK
Detailed Description	N-Channel 60 V 16A (Tc) 40W (Tc) Surface Mount DPAK

This model STD16NF06T4 is available at DiGi Electronics.

DiGi Electronics offers a global database of semiconductor and electronic component datasheets.

We welcome your inquiries regarding pricing, lead time, or other product-related questions.

 [Request a Quote](#)

 [Datasheet Search](#)



Tel: +00 852-30501935

RFQ Email: Info@DiGi-Electronics.com

DiGi is a global authorized distributor of electronic components.

Purchase and inquiry

Manufacturer Product Number:

STD16NF06T4

Series:

STripFET™ II

FET Type:

N-Channel

Drain to Source Voltage (Vdss):

60 V

Drive Voltage (Max Rds On, Min Rds On):

10V

Vgs(th) (Max) @ Id:

2V @ 250µA

Vgs (Max):

±20V

FET Feature:

-

Operating Temperature:

-55°C ~ 175°C (Tj)

Supplier Device Package:

DPAK

Base Product Number:

STD16

Manufacturer:

STMicroelectronics

Product Status:

Active

Technology:

MOSFET (Metal Oxide)

Current - Continuous Drain (Id) @ 25°C:

16A (Tc)

Rds On (Max) @ Id, Vgs:

70mOhm @ 8A, 10V

Gate Charge (Qg) (Max) @ Vgs:

14.1 nC @ 10 V

Input Capacitance (Ciss) (Max) @ Vds:

400 pF @ 15 V

Power Dissipation (Max):

40W (Tc)

Mounting Type:

Surface Mount

Package / Case:

TO-252-3, DPAK (2 Leads + Tab), SC-63

Environmental & Export classification

RoHS Status:

ROHS3 Compliant

REACH Status:

REACH Unaffected

HTSUS:

8541.29.0095

Moisture Sensitivity Level (MSL):

1 (Unlimited)

ECCN:

EAR99



STD16NF06

N-Channel 60V - 0.060Ω - 16A - DPAK
STripFET™ II Power MOSFET

General features

Type	V _{DSS}	R _{DS(on)}	I _D
STD16NF06	60V	<0.070Ω	16A

- Typical R_{DS(on)} = 0.060Ω
- Exceptional dv/dt Capability
- 100% Avalanche Tested
- Application Oriented Characterization

Description

This Power MOSFET is the latest development of STMicroelectronics unique "Single Feature Size™" strip-based process. The resulting transistor shows extremely high packing density for low on-resistance, rugged avalanche characteristics and less critical alignment steps therefore a remarkable manufacturing reproducibility

Applications

- Audio Amplifiers
- Power Tools
- Automotive Environment

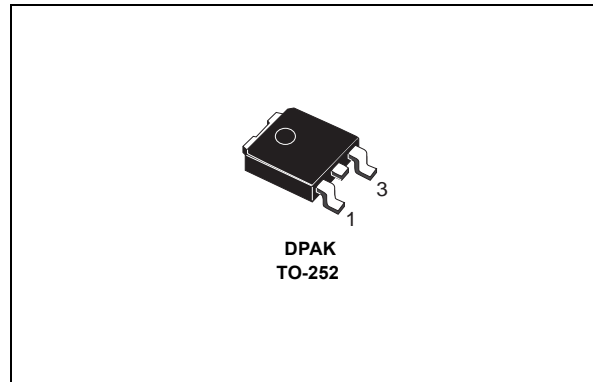

Internal schematic diagram

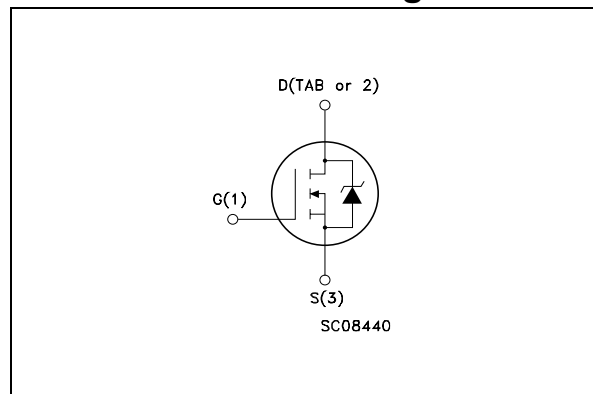

Order codes

Part Number	Marking	Package	Packaging
STD16NF06T4	D16NF06	TO-252	TAPE & REEL

1 Electrical ratings

Table 1. Absolute maximum ratings

Symbol	Parameter	Value	Unit
V_{DS}	Drain-source Voltage ($V_{GS} = 0V$)	60	V
V_{DGR}	Drain-gate Voltage ($R_{GS} = 20\text{ k}\Omega$)	60	V
V_{GS}	Gate-Source Voltage	± 20	V
I_D	Drain Current (continuous) at $T_C = 25^\circ\text{C}$	16	A
I_D	Drain Current (continuous) at $T_C = 100^\circ\text{C}$	11	A
I_{DM} <i>Note 4</i>	Drain Current (pulsed)	64	A
P_{TOT}	Total Dissipation at $T_C = 25^\circ\text{C}$	40	W
	Derating Factor	0.27	W/ $^\circ\text{C}$
dv/dt	Peak Diode Recovery voltage slope	10.5	V/ns
EAS	Single Pulse Avalanche Energy	178	mJ
T_J T_{stg}	Operating Junction Temperature Storage Temperature	-55 to 175	$^\circ\text{C}$

Table 2. Thermal data

R_{thJC}	Thermal Resistance Junction-case Max	3.75	$^\circ\text{C}/\text{W}$
R_{thJA}	Thermal Resistance Junction-amb Max	100	$^\circ\text{C}/\text{W}$
T_I	Maximum Lead Temperature For Soldering Purpose	275	$^\circ\text{C}$

2 Electrical characteristics

($T_{CASE} = 25\text{ }^{\circ}\text{C}$ unless otherwise specified)

Table 3. On/off states

Symbol	Parameter	Test Conditions	Min.	Typ.	Max.	Unit
$V_{(BR)DSS}$	Drain-Source Breakdown Voltage	$I_D = 250\mu\text{A}$ $V_{GS} = 0$	60			V
I_{DSS}	Zero Gate Voltage Drain Current ($V_{GS} = 0$)	$V_{DS} = \text{Max Rating}$ $V_{DS} = \text{Max Rating}$ $T_C = 125^{\circ}\text{C}$			1 10	μA μA
I_{GSS}	Gate Body Leakage Current ($V_{DS} = 0$)	$V_{GS} = \pm 20\text{V}$			± 100	μA
$V_{GS(th)}$	Gate Threshold Voltage	$V_{DS} = V_{GS}$ $I_D = 250\mu\text{A}$	2			V
$R_{DS(on)}$	Static Drain-Source On Resistance	$V_{GS} = 10\text{V}$ $I_D = 8\text{A}$		0.060	0.070	Ω

Table 4. Dynamic

Symbol	Parameter	Test Conditions	Min.	Typ.	Max.	Unit
g_{fs} <i>Note 5</i>	Forward Transconductance	$V_{DS} = 25\text{V}$ $I_D = 8\text{A}$		6		S
C_{iss} C_{oss} C_{rss}	Input Capacitance Output Capacitance Reverse Transfer Capacitance	$V_{DS} = 15\text{V}$, $f = 1\text{MHz}$, $V_{GS} = 0$		400 103 41.5		pF pF pF
Q_g Q_{gs} Q_{gd}	Total Gate Charge Gate-Source Charge Gate-Drain Charge	$V_{DD} = 30$ $I_D = 16\text{A}$ $V_{GS} = 10\text{V}$ <i>Figure 14 on page 7</i>		14.1 2.8 5.4		nC nC nC

Table 5. Switching times

Symbol	Parameter	Test Conditions	Min.	Typ.	Max.	Unit
$t_{d(on)}$ t_r	Turn-on Delay Time Rise Time	$V_{DD} = 30\text{V}$, $I_D = 8\text{A}$, $R_G = 4.7\Omega$, $V_{GS} = 10\text{V}$ <i>Figure 13 on page 7</i>		4 15		ns ns
$t_{d(off)}$ t_f	Off voltage Rise Time FallTime	$V_{DD} = 30\text{V}$, $I_D = 8\text{A}$, $R_G = 4.7\Omega$, $V_{GS} = 10\text{V}$ <i>Figure 15 on page 7</i>		16 5.5		ns ns

Table 6. Source drain diode

Symbol	Parameter	Test Conditions	Min.	Typ.	Max.	Unit
I_{SD}	Source-drain Current				16	A
I_{SDM} <i>Note 4</i>	Source-drain Current (pulsed)				64	A
V_{SD} <i>Note 5</i>	Forward on Voltage	$I_{SD} = 8A$ $V_{GS} = 0$			1.5	V
t_{rr}	Reverse Recovery Time	$I_{SD} = 16A$, $di/dt = 100A/\mu s$, $V_{DD} = 20V$, $T_J = 150^\circ C$ <i>Figure 15 on page 7</i>		49		ns
Q_{rr}	Reverse Recovery Charge			78		μC
I_{RRM}	Reverse Recovery Current			3.2		A

Note: 1 Value limited by wire bonding

2 Garanted when external $R_g=4.7 \Omega$ and $t_f < t_{fmax}$.

3 Starting $T_J = 25^\circ C$, $I_D = 19A$, $V_{DD} = 18V$

4 Pulse width limited by safe operating area

5 Pulsed: pulse duration = $300\mu s$, duty cycle 1.5%

2.1 Electrical characteristics (curves)

Figure 1. Safe Operating Area

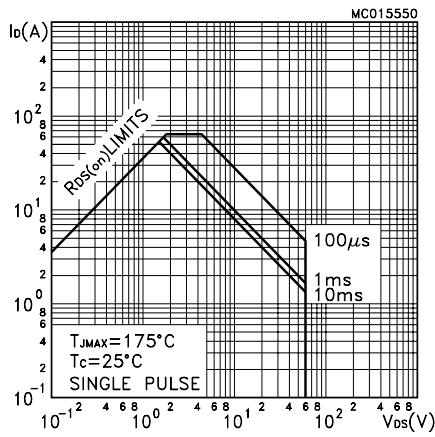

Figure 2. Thermal Impedance

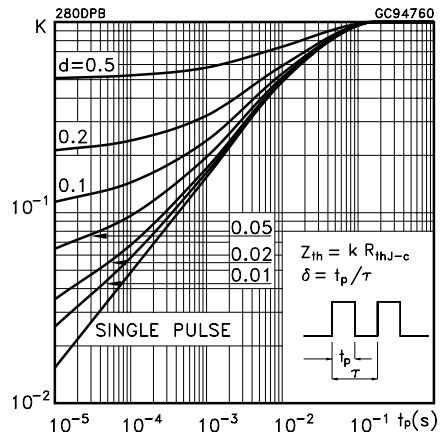

Figure 3. Output Characteristics

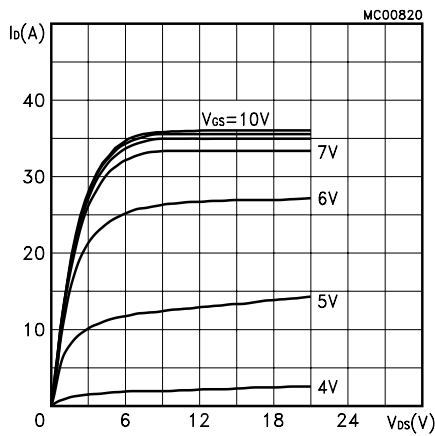

Figure 4. Transfer Characteristics

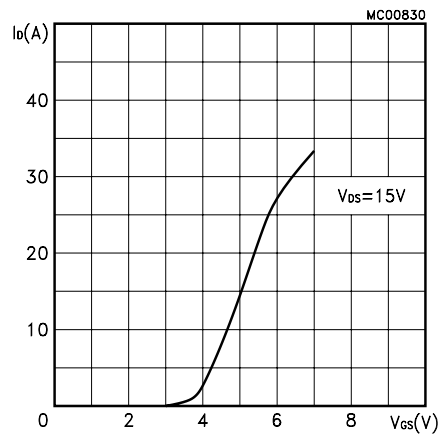

Figure 5. Transconductance

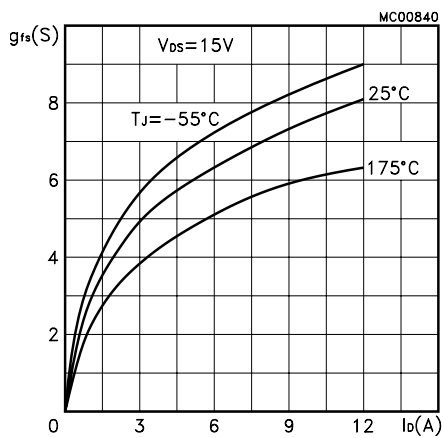

Figure 6. Static Drain-Source on Resistance

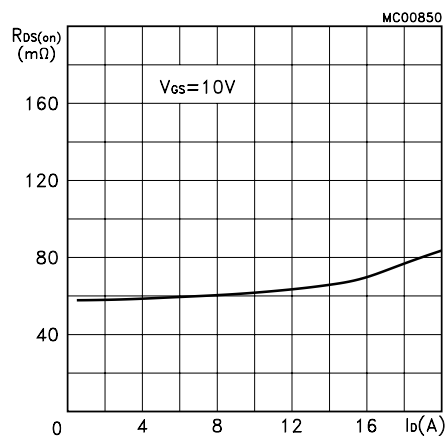

Figure 7. Gate Charge vs Gate-Source Voltage Figure 8. Capacitance Variations

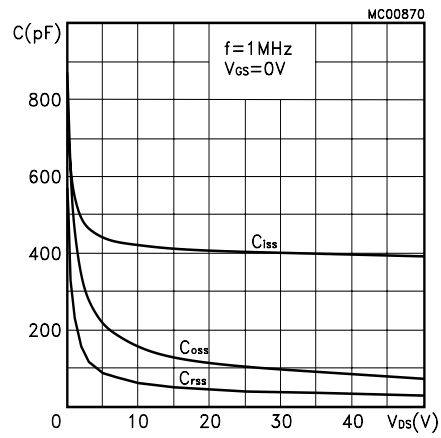
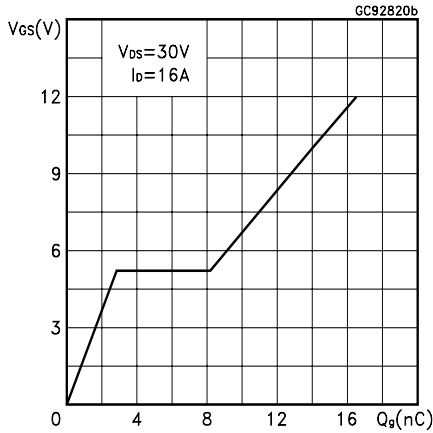

Figure 9. Normalized Gate Threshold Voltage vs Temperature Figure 10. Normalized on Resistance vs Temperature

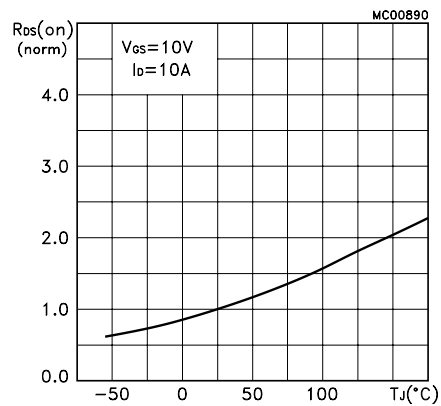
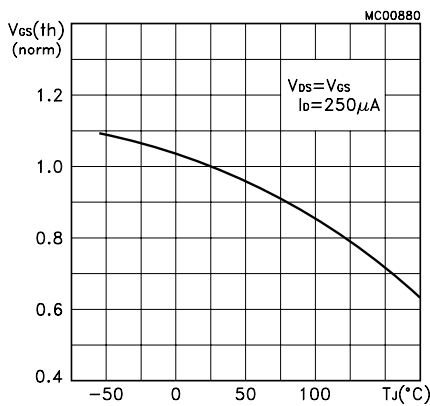
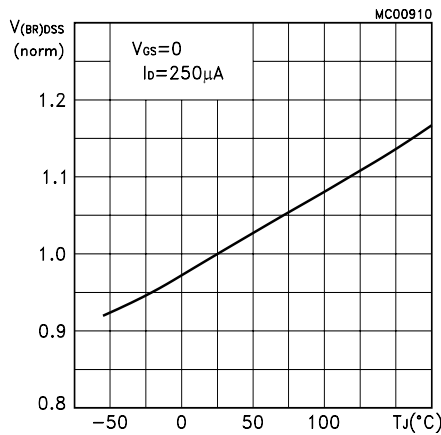
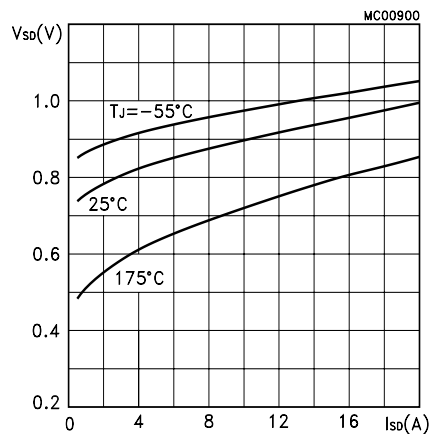

Figure 11. Source-drain Diode Forward Characteristics

Figure 12. Normalized Breakdown Voltage vs Temperature



3 Test circuits

Figure 13. Switching Times Test Circuit For Resistive Load

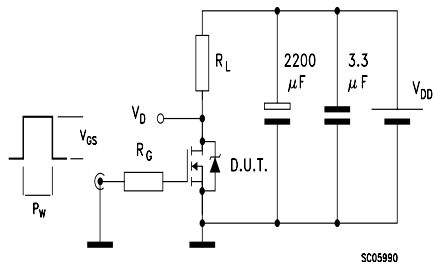

Figure 14. Gate Charge Test Circuit

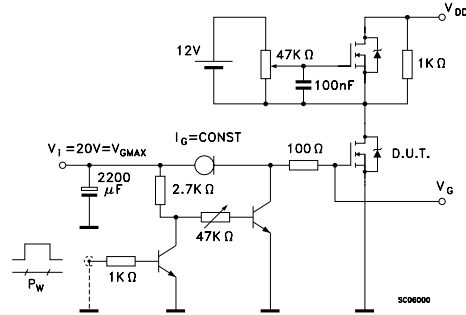

Figure 15. Test Circuit For Inductive Load Switching and Diode Recovery Times

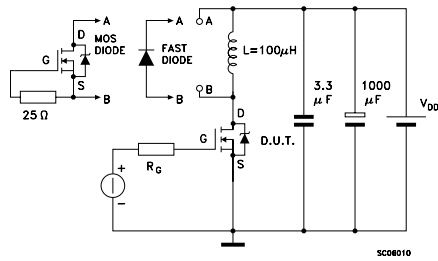

Figure 17. Unclamped Inductive Load Test Circuit

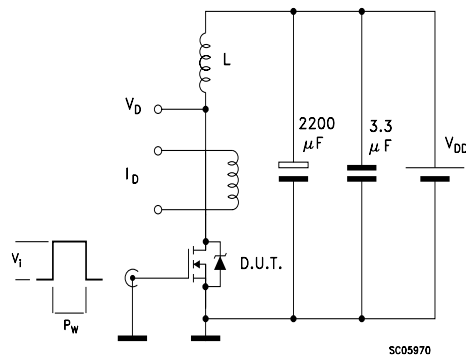
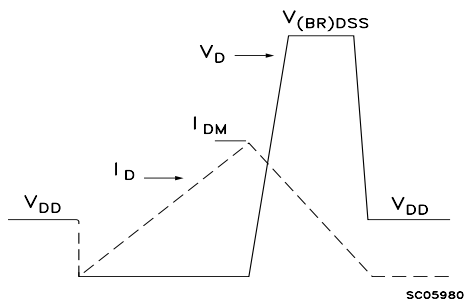

Figure 16. Unclamped Inductive Waveform



4 Package mechanical data

In order to meet environmental requirements, ST offers these devices in ECOPACK® packages. These packages have a Lead-free second level interconnect . The category of second level interconnect is marked on the package and on the inner box label, in compliance with JEDEC Standard JESD97. The maximum ratings related to soldering conditions are also marked on the inner box label. ECOPACK is an ST trademark. ECOPACK specifications are available at: www.st.com

TO-252 (DPAK) MECHANICAL DATA

DIM.	mm			inch		
	MIN.	TYP.	MAX.	MIN.	TYP.	MAX.
A	2.2		2.4	0.086		0.094
A1	0.9		1.1	0.035		0.043
A2	0.03		0.23	0.001		0.009
B	0.64		0.9	0.025		0.035
B2	5.2		5.4	0.204		0.212
C	0.45		0.6	0.017		0.023
C2	0.48		0.6	0.019		0.023
D	6		6.2	0.236		0.244
E	6.4		6.6	0.252		0.260
G	4.4		4.6	0.173		0.181
H	9.35		10.1	0.368		0.397
L2		0.8			0.031	
L4	0.6		1	0.023		0.039

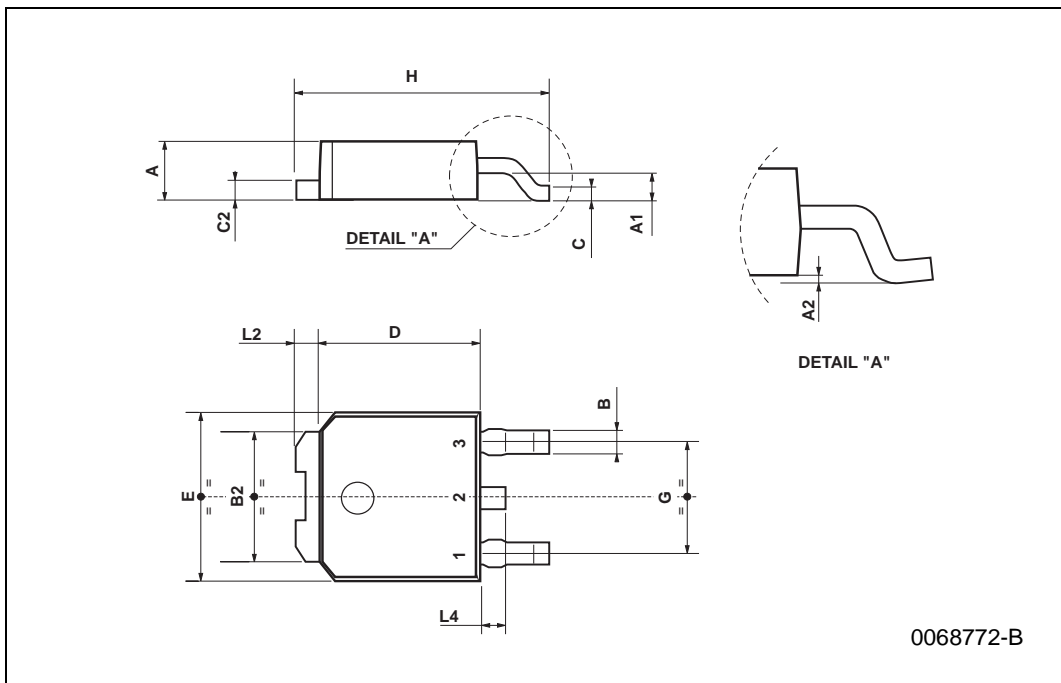

5 Revision History

Date	Revision	Description of changes
10-Jan-2006	1	First release

Information furnished is believed to be accurate and reliable. However, STMicroelectronics assumes no responsibility for the consequences of use of such information nor for any infringement of patents or other rights of third parties which may result from its use. No license is granted by implication or otherwise under any patent or patent rights of STMicroelectronics. Specifications mentioned in this publication are subject to change without notice. This publication supersedes and replaces all information previously supplied. STMicroelectronics products are not authorized for use as critical components in life support devices or systems without express written approval of STMicroelectronics.

The ST logo is a registered trademark of STMicroelectronics.
All other names are the property of their respective owners

© 2006 STMicroelectronics - All rights reserved

STMicroelectronics group of companies

Australia - Belgium - Brazil - Canada - China - Czech Republic - Finland - France - Germany - Hong Kong - India - Israel - Italy - Japan -
Malaysia - Malta - Morocco - Singapore - Spain - Sweden - Switzerland - United Kingdom - United States of America

www.st.com



OUR CERTIFICATE

DiGi provide top-quality products and perfect service for customer worldwide through standardization, technological innovation and continuous improvement. DiGi through third-party certification, we stricly control the quality of products and services. Welcome your RFQ to

Email: Info@DiGi-Electronics.com



Tel: +00 852-30501935

RFQ Email: Info@DiGi-Electronics.com

DiGi is a global authorized distributor of electronic components.