

STD70N2LH5 Datasheet



<https://www.DiGi-Electronics.com>

DiGi Electronics Part Number	STD70N2LH5-DG
Manufacturer	STMicroelectronics
Manufacturer Product Number	STD70N2LH5
Description	MOSFET N-CH 25V 48A DPAK
Detailed Description	N-Channel 25 V 48A (Tc) 60W (Tc) Surface Mount DPAK

This model STD70N2LH5 is available at DiGi Electronics.

DiGi Electronics offers a global database of semiconductor and electronic component datasheets.

We welcome your inquiries regarding pricing, lead time, or other product-related questions.

 [Request a Quote](#)

 [Datasheet Search](#)



Tel: +00 852-30501935

RFQ Email: Info@DiGi-Electronics.com

DiGi is a global authorized distributor of electronic components.

Purchase and inquiry

Manufacturer Product Number:

STD70N2LH5

Series:

STripFET™ V

FET Type:

N-Channel

Drain to Source Voltage (Vdss):

25 V

Drive Voltage (Max Rds On, Min Rds On):

5V, 10V

Vgs(th) (Max) @ Id:

1V @ 250μA

Vgs (Max):

±22V

FET Feature:

-

Operating Temperature:

-55°C ~ 175°C (Tj)

Supplier Device Package:

DPAK

Base Product Number:

STD70N

Manufacturer:

STMicroelectronics

Product Status:

Obsolete

Technology:

MOSFET (Metal Oxide)

Current - Continuous Drain (Id) @ 25°C:

48A (Tc)

Rds On (Max) @ Id, Vgs:

7.1mOhm @ 24A, 10V

Gate Charge (Qg) (Max) @ Vgs:

8 nC @ 5 V

Input Capacitance (Ciss) (Max) @ Vds:

1300 pF @ 25 V

Power Dissipation (Max):

60W (Tc)

Mounting Type:

Surface Mount

Package / Case:

TO-252-3, DPAK (2 Leads + Tab), SC-63

Environmental & Export classification

RoHS Status:

ROHS3 Compliant

REACH Status:

REACH Unaffected

HTSUS:

8541.29.0095

Moisture Sensitivity Level (MSL):

1 (Unlimited)

ECCN:

EAR99



STD70N2LH5 STU70N2LH5

N-channel 25 V, 0.006 Ω , 48 A - DPAK - IPAK
STripFET™ V Power MOSFET

Preliminary Data

Features

Type	V _{DSS}	R _{DS(on)} max	I _D
STD70N2LH5	25 V	0.0071 Ω	48 A
STU70N2LH5	25 V	0.0075 Ω	48 A

- R_{DS(on)} * Q_g industry benchmark
- Extremely low on-resistance R_{DS(on)}
- Very low switching gate charge
- High avalanche ruggedness
- Low gate drive power losses

Application

- Switching applications

Description

This product utilizes the 5th generation of design rules of ST's proprietary STripFET™ technology. The lowest available R_{DS(on)}*Q_g, in the standard packages, makes this device suitable for the most demanding DC-DC converter applications, where high power density is to be achieved.

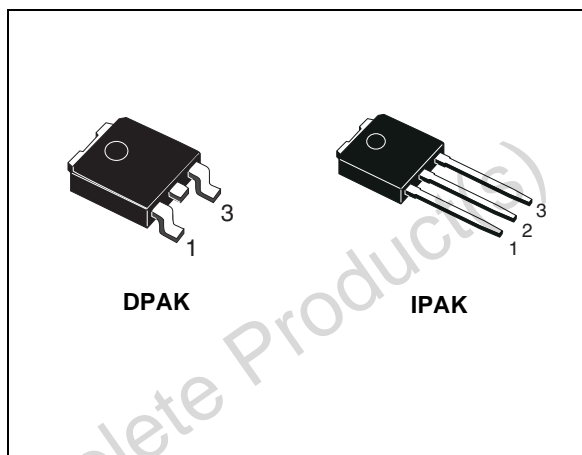

Figure 1. Internal schematic diagram

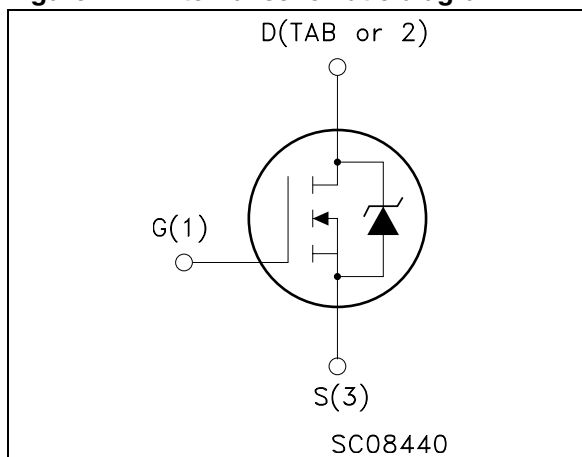

Table 1. Device summary

Order codes	Marking	Package	Packaging
STD70N2LH5	70N2LH5	DPAK	Tape & reel
STU70N2LH5	70N2LH5	IPAK	Tube

1 Electrical ratings

Table 2. Absolute maximum ratings

Symbol	Parameter	Value	Unit
V_{DS}	Drain-source voltage ($V_{GS}=0$)	25	V
V_{GS}	Gate-Source voltage	± 22	V
$I_D^{(1)}$	Drain current (continuous) at $T_C = 25\text{ }^\circ\text{C}$	48	A
I_D	Drain current (continuous) at $T_C = 100\text{ }^\circ\text{C}$	43	A
$I_{DM}^{(2)}$	Drain current (pulsed)	192	A
P_{TOT}	Total dissipation at $T_C = 25\text{ }^\circ\text{C}$	60	W
	Derating factor	0.4	W/ $^\circ\text{C}$
$E_{AS}^{(3)}$	Single pulse avalanche energy	TBD	mJ
T_j T_{stg}	Operating junction temperature Storage temperature	-55 to 175	$^\circ\text{C}$

1. Limited by wire bonding
2. Pulse width limited by safe operating area
3. Starting $T_j = 25\text{ }^\circ\text{C}$, $I_D = 24\text{ A}$, $V_{DD} = 12\text{ V}$

Table 3. Thermal resistance

Symbol	Parameter	Value	Unit
$R_{thj-case}$	Thermal resistance junction-case max	2.5	$^\circ\text{C/W}$
$R_{thj-amb}$	Thermal resistance junction-case max	100	$^\circ\text{C/W}$
T_j	Maximum lead temperature for soldering purpose	275	$^\circ\text{C}$

2 Electrical characteristics

($T_{CASE} = 25^{\circ}\text{C}$ unless otherwise specified)

Table 4. Static

Symbol	Parameter	Test conditions	Min.	Typ.	Max.	Unit
$V_{(BR)DSS}$	Drain-source breakdown Voltage	$I_D = 250 \mu\text{A}$, $V_{GS} = 0$	25			V
I_{DSS}	Zero gate voltage drain current ($V_{GS} = 0$)	$V_{DS} = 25 \text{ V}$ $V_{DS} = 25 \text{ V}$, $T_C = 125^{\circ}\text{C}$			1 10	μA μA
I_{GSS}	Gate body leakage current ($V_{DS} = 0$)	$V_{GS} = \pm 22 \text{ V}$			± 100	nA
$V_{GS(th)}$	Gate threshold voltage	$V_{DS} = V_{GS}$, $I_D = 250 \mu\text{A}$	1			V
$R_{DS(on)}$	Static drain-source on resistance	$V_{GS} = 10 \text{ V}$, $I_D = 24 \text{ A}$ SMD version		0.006	0.0071	Ω
		$V_{GS} = 10 \text{ V}$, $I_D = 24 \text{ A}$		0.0064	0.0075	Ω
		$V_{GS} = 5 \text{ V}$, $I_D = 24 \text{ A}$ SMD version		0.008	0.01	Ω
		$V_{GS} = 5 \text{ V}$, $I_D = 24 \text{ A}$		0.0084	0.0104	Ω

Table 5. Dynamic

Symbol	Parameter	Test conditions	Min	Typ.	Max.	Unit
C_{iss}	Input capacitance	$V_{DS} = 25 \text{ V}$, $f = 1 \text{ MHz}$, $V_{GS} = 0$		1300		pF
C_{oss}	Output capacitance			300		pF
C_{rss}	Reverse transfer capacitance			50		pF
Q_g	Total gate charge	$V_{DD} = 15 \text{ V}$, $I_D = 48 \text{ A}$		8		nC
Q_{gs}	Gate-source charge	$V_{GS} = 5 \text{ V}$		TBD		nC
Q_{gd}	Gate-drain charge	(Figure 3)		TBD		nC
Q_{gs1}	Pre V_{th} gate-to-source charge	$V_{DD} = 15 \text{ V}$, $I_D = 48 \text{ A}$		TBD		nC
Q_{gs2}	Post V_{th} gate-to-source charge	$V_{GS} = 5 \text{ V}$ (Figure 8)		TBD		nC
R_G	Gate input resistance	$f = 1 \text{ MHz}$ gate bias Bias = 0 test signal level = 20 mV open drain		1.1		Ω

Electrical characteristics

STD70N2LH5 - STU70N2LH5

Table 6. Switching on/off (resistive load)

Symbol	Parameter	Test conditions	Min.	Typ.	Max.	Unit
$t_{d(on)}$ t_r	Turn-on delay time Rise time	$V_{DD}=10\text{ V}$, $I_D=24\text{ A}$, $R_G=4.7\ \Omega$, $V_{GS}=10\text{ V}$ (Figure 2 and Figure 7)		TBD TBD		ns ns
$t_{d(off)}$ t_f	Turn-off delay time Fall time	$V_{DD}=10\text{ V}$, $I_D=24\text{ A}$, $R_G=4.7\ \Omega$, $V_{GS}=10\text{ V}$ (Figure 2 and Figure 7)		TBD TBD		ns ns

Table 7. Source drain diode

Symbol	Parameter	Test conditions	Min.	Typ.	Max.	Unit
I_{SD}	Source-drain current				48	A
I_{SDM}	Source-drain current (pulsed) ⁽¹⁾				192	A
V_{SD}	Forward on voltage	$I_{SD}=24\text{ A}$, $V_{GS}=0$			1.1	V
t_{rr}	Reverse recovery time	$I_{SD}=48\text{ A}$, $di/dt=100\text{ A}/\mu\text{s}$, $V_{DD}=20\text{ V}$, $T_j=25\text{ }^\circ\text{C}$ (Figure 4)		TBD		ns
Q_{rr}	Reverse recovery charge			TBD		nC
I_{RRM}	Reverse recovery current			TBD		A

1. Pulsed: pulse duration = 300 μs , duty cycle 1.5%

3 Test circuit

Figure 2. Switching times test circuit for resistive load

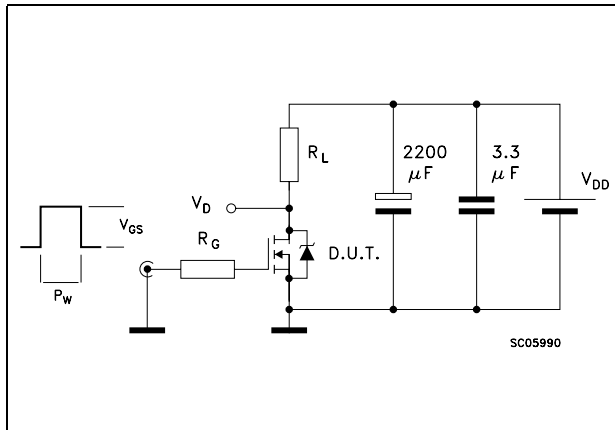

Figure 3. Gate charge test circuit

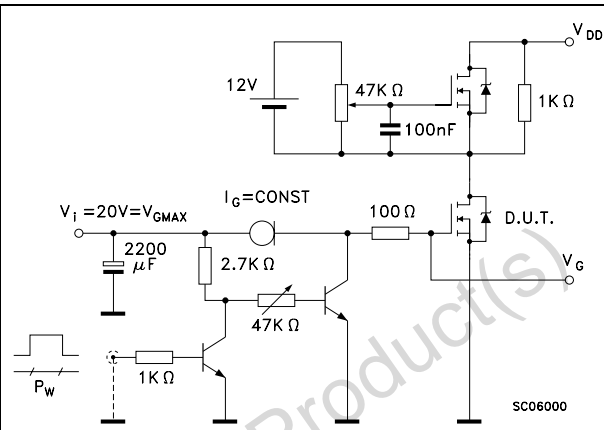

Figure 4. Test circuit for inductive load switching and diode recovery times

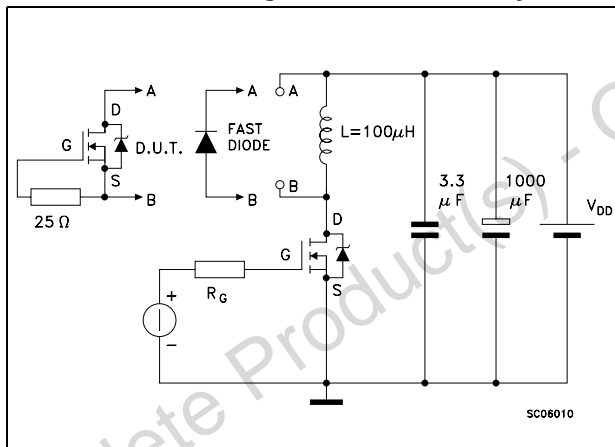

Figure 5. Unclamped Inductive load test circuit

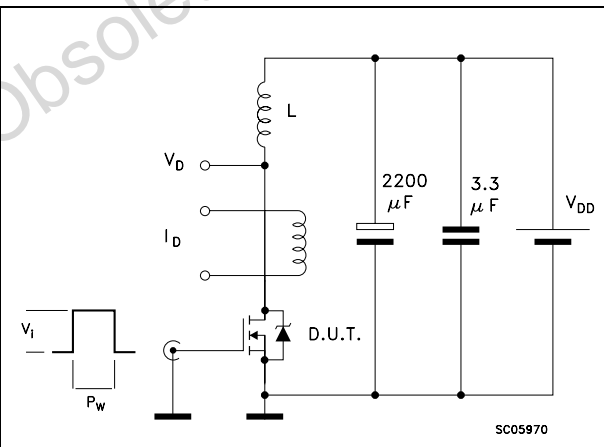

Figure 6. Unclamped inductive waveform

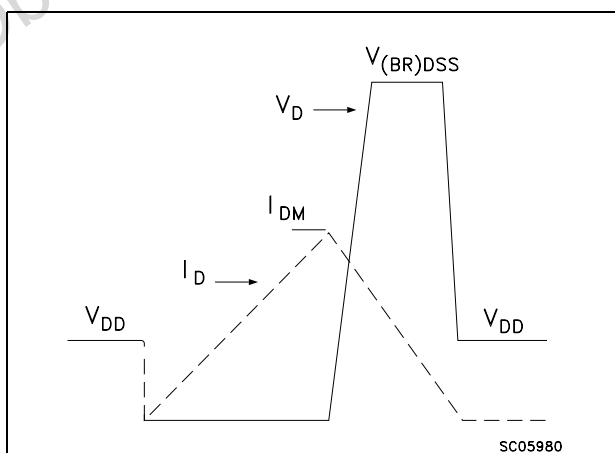

Figure 7. Switching time waveform

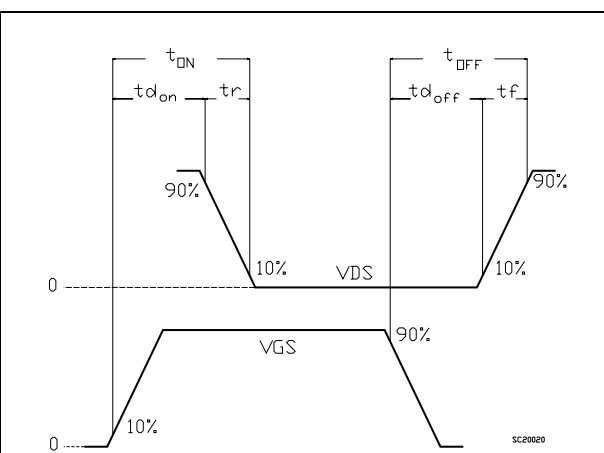
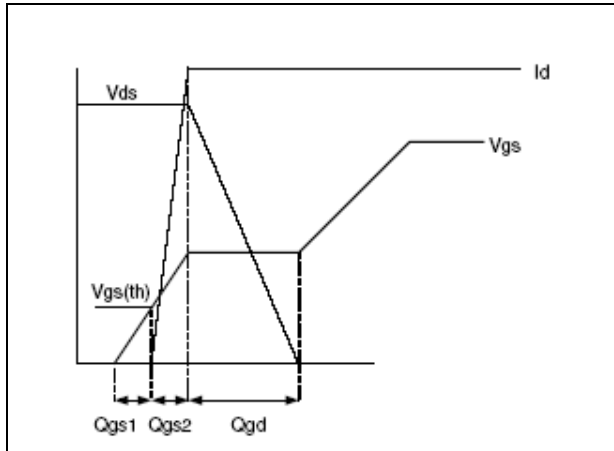

Figure 8. Gate charge waveform



Obsolete Product(s) - Obsolete Product(s)

4 Package mechanical data

In order to meet environmental requirements, ST offers these devices in ECOPACK® packages. These packages have a lead-free second level interconnect. The category of second level interconnect is marked on the package and on the inner box label, in compliance with JEDEC Standard JESD97. The maximum ratings related to soldering conditions are also marked on the inner box label. ECOPACK is an ST trademark. ECOPACK specifications are available at: www.st.com

Obsolete Product(s) - Obsolete Product(s)

DPAK MECHANICAL DATA

DIM.	mm.			inch		
	MIN.	TYP.	MAX.	MIN.	TYP.	MAX.
A	2.2		2.4	0.086		0.094
A1	0.9		1.1	0.035		0.043
A2	0.03		0.23	0.001		0.009
B	0.64		0.9	0.025		0.035
b4	5.2		5.4	0.204		0.212
C	0.45		0.6	0.017		0.023
C2	0.48		0.6	0.019		0.023
D	6		6.2	0.236		0.244
D1		5.1			0.200	
E	6.4		6.6	0.252		0.260
E1		4.7			0.185	
e		2.28			0.090	
e1	4.4		4.6	0.173		0.181
H	9.35		10.1	0.368		0.397
L	1			0.039		
(L1)		2.8			0.110	
L2		0.8			0.031	
L4	0.6		1	0.023		0.039
R		0.2			0.008	
V2	0°		8°	0°		8°

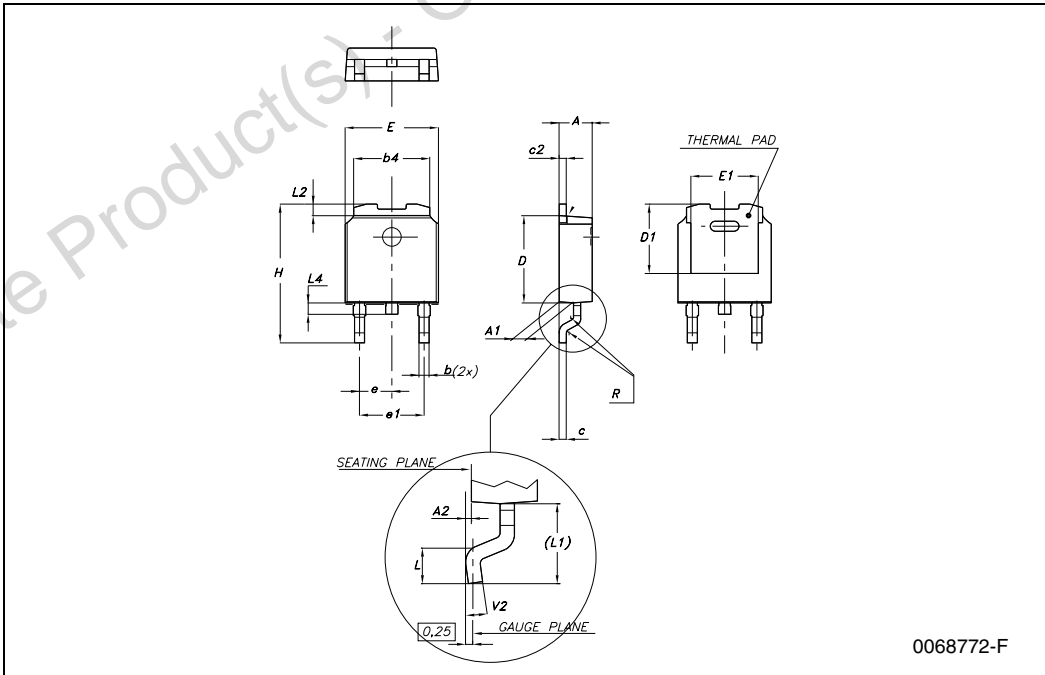

0068772-F

TO-251 (IPAK) MECHANICAL DATA

DIM.	mm			inch		
	MIN.	TYP.	MAX.	MIN.	TYP.	MAX.
A	2.2		2.4	0.086		0.094
A1	0.9		1.1	0.035		0.043
A3	0.7		1.3	0.027		0.051
B	0.64		0.9	0.025		0.031
B2	5.2		5.4	0.204		0.212
B3			0.85			0.033
B5		0.3			0.012	
B6			0.95			0.037
C	0.45		0.6	0.017		0.023
C2	0.48		0.6	0.019		0.023
D	6		6.2	0.236		0.244
E	6.4		6.6	0.252		0.260
G	4.4		4.6	0.173		0.181
H	15.9		16.3	0.626		0.641
L	9		9.4	0.354		0.370
L1	0.8		1.2	0.031		0.047
L2		0.8	1		0.031	0.039

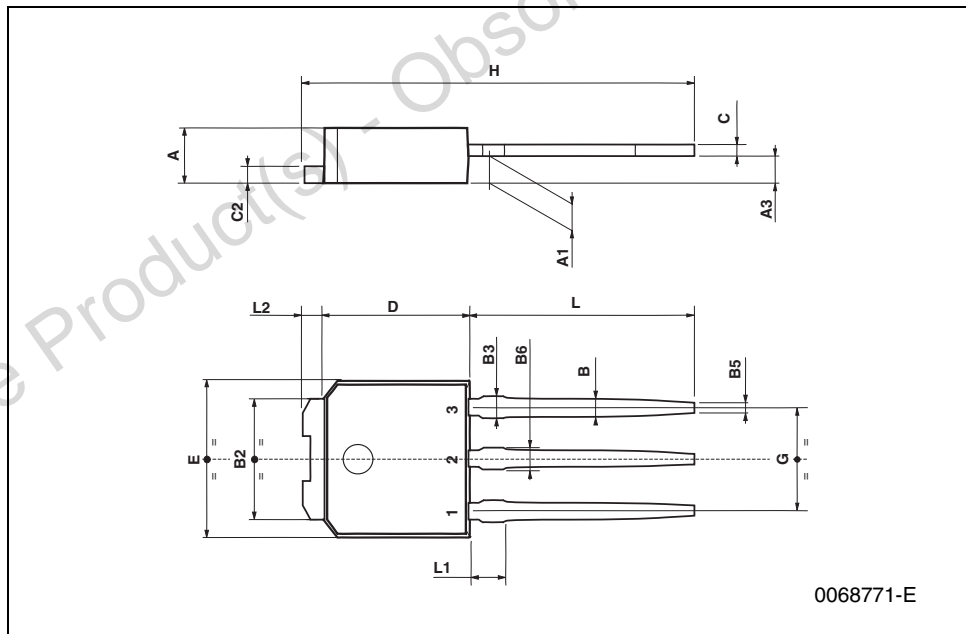

5 Packaging mechanical data

DPAK FOOTPRINT

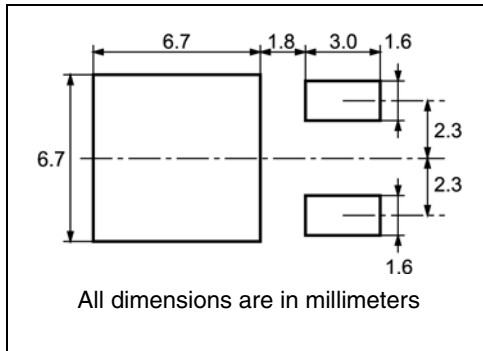

TAPE AND REEL SHIPMENT

40 mm min. Access hole at slot location

Tape slot in core for tape start 2.5mm min. width

G measured at hub

DIM.	mm		inch	
	MIN.	MAX.	MIN.	MAX.
A		330		12.992
B	1.5		0.059	
C	12.8	13.2	0.504	0.520
D	20.2		0.795	
G	16.4	18.4	0.645	0.724
N	50		1.968	
T		22.4		0.881

BASE QTY	BULK QTY
2500	2500

TAPE MECHANICAL DATA

DIM.	mm		inch	
	MIN.	MAX.	MIN.	MAX.
A0	6.8	7	0.267	0.275
B0	10.4	10.6	0.409	0.417
B1		12.1		0.476
D	1.5	1.6	0.059	0.063
D1	1.5		0.059	
E	1.65	1.85	0.065	0.073
F	7.4	7.6	0.291	0.299
K0	2.55	2.75	0.100	0.108
P0	3.9	4.1	0.153	0.161
P1	7.9	8.1	0.311	0.319
P2	1.9	2.1	0.075	0.082
R	40		1.574	
W	15.7	16.3	0.618	0.641

10 pitches cumulative tolerance on tape +/- 0.2 mm

Center line of cavity

User Direction of Feed

Bending radius R min.

FEED DIRECTION

For machine ref. only including draft and radii concentric around B0

6 Revision history

Table 8. Document revision history

Date	Revision	Changes
16-Jan-2008	1	First release
23-Sep-2008	2	V_{GS} value has been changed on Table 2 and Table 5

Obsolete Product(s) - Obsolete Product(s)

Please Read Carefully:

Information in this document is provided solely in connection with ST products. STMicroelectronics NV and its subsidiaries ("ST") reserve the right to make changes, corrections, modifications or improvements, to this document, and the products and services described herein at any time, without notice.

All ST products are sold pursuant to ST's terms and conditions of sale.

Purchasers are solely responsible for the choice, selection and use of the ST products and services described herein, and ST assumes no liability whatsoever relating to the choice, selection or use of the ST products and services described herein.

No license, express or implied, by estoppel or otherwise, to any intellectual property rights is granted under this document. If any part of this document refers to any third party products or services it shall not be deemed a license grant by ST for the use of such third party products or services, or any intellectual property contained therein or considered as a warranty covering the use in any manner whatsoever of such third party products or services or any intellectual property contained therein.

UNLESS OTHERWISE SET FORTH IN ST'S TERMS AND CONDITIONS OF SALE ST DISCLAIMS ANY EXPRESS OR IMPLIED WARRANTY WITH RESPECT TO THE USE AND/OR SALE OF ST PRODUCTS INCLUDING WITHOUT LIMITATION IMPLIED WARRANTIES OF MERCHANTABILITY, FITNESS FOR A PARTICULAR PURPOSE (AND THEIR EQUIVALENTS UNDER THE LAWS OF ANY JURISDICTION), OR INFRINGEMENT OF ANY PATENT, COPYRIGHT OR OTHER INTELLECTUAL PROPERTY RIGHT.

UNLESS EXPRESSLY APPROVED IN WRITING BY AN AUTHORIZED ST REPRESENTATIVE, ST PRODUCTS ARE NOT RECOMMENDED, AUTHORIZED OR WARRANTED FOR USE IN MILITARY, AIR CRAFT, SPACE, LIFE SAVING, OR LIFE SUSTAINING APPLICATIONS, NOR IN PRODUCTS OR SYSTEMS WHERE FAILURE OR MALFUNCTION MAY RESULT IN PERSONAL INJURY, DEATH, OR SEVERE PROPERTY OR ENVIRONMENTAL DAMAGE. ST PRODUCTS WHICH ARE NOT SPECIFIED AS "AUTOMOTIVE GRADE" MAY ONLY BE USED IN AUTOMOTIVE APPLICATIONS AT USER'S OWN RISK.

Resale of ST products with provisions different from the statements and/or technical features set forth in this document shall immediately void any warranty granted by ST for the ST product or service described herein and shall not create or extend in any manner whatsoever, any liability of ST.

ST and the ST logo are trademarks or registered trademarks of ST in various countries.

Information in this document supersedes and replaces all information previously supplied.

The ST logo is a registered trademark of STMicroelectronics. All other names are the property of their respective owners.

© 2008 STMicroelectronics - All rights reserved

STMicroelectronics group of companies

Australia - Belgium - Brazil - Canada - China - Czech Republic - Finland - France - Germany - Hong Kong - India - Israel - Italy - Japan - Malaysia - Malta - Morocco - Singapore - Spain - Sweden - Switzerland - United Kingdom - United States of America

www.st.com

OUR CERTIFICATE

DiGi provide top-quality products and perfect service for customer worldwide through standardization, technological innovation and continuous improvement. DiGi through third-party certification, we stricly control the quality of products and services. Welcome your RFQ to

Email: Info@DiGi-Electronics.com



Tel: +00 852-30501935

RFQ Email: Info@DiGi-Electronics.com

DiGi is a global authorized distributor of electronic components.