

# STDRIVE601 Datasheet



www.digi-electronics.com

<https://www.DiGi-Electronics.com>

DiGi Electronics Part Number	STDRIVE601-DG
Manufacturer	<a href="#">STMicroelectronics</a>
Manufacturer Product Number	STDRIVE601
Description	IC HALF BRIDGE DRIVER 28SO
Detailed Description	Half Bridge (3) Driver DC Motors, General Purpose Power MOSFET, IGBT 28-SO

This model STDRIVE601 is available at DiGi Electronics.

DiGi Electronics offers a global database of semiconductor and electronic component datasheets.

We welcome your inquiries regarding pricing, lead time, or other product-related questions.

 [Request a Quote](#)

 [Datasheet Search](#)



Tel: +00 852-30501935

RFQ Email: [Info@DiGi-Electronics.com](mailto:Info@DiGi-Electronics.com)

DiGi is a global authorized distributor of electronic components.

## Purchase and inquiry

Manufacturer Product Number:

STDRIVE601

Series:

-

Output Configuration:

Half Bridge (3)

Interface:

Analog, Logic

Technology:

Power MOSFET, IGBT

Current - Output / Channel:

-

Voltage - Supply:

9V ~ 20V

Operating Temperature:

-40°C ~ 125°C (TJ)

Fault Protection:

Over Current, Over Temperature, UVLO

Package / Case:

28-SOIC (0.295", 7.50mm Width)

Base Product Number:

STDRIVE601

Manufacturer:

STMicroelectronics

Product Status:

Active

Applications:

DC Motors, General Purpose

Load Type:

Capacitive and Resistive

Rds On (Typ):

350hm

Current - Peak Output:

350mA

Voltage - Load:

580V

Features:

Bootstrap Circuit

Mounting Type:

Surface Mount

Supplier Device Package:

28-SO

## Environmental & Export classification

RoHS Status:

ROHS3 Compliant

REACH Status:

REACH Unaffected

HTSUS:

8542.39.0001

Moisture Sensitivity Level (MSL):

3 (168 Hours)

ECCN:

EAR99

## Triple half-bridge high-voltage gate driver

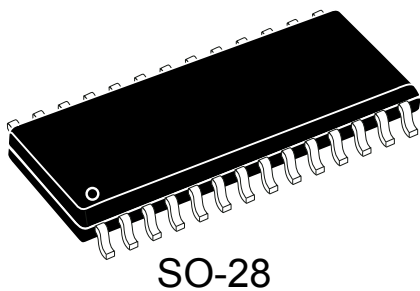

SO-28

### Features

- High voltage rail up to 600 V
- Driver current capability:
  - 200 mA source current @ 25 °C
  - 350 mA sink current @ 25 °C
- dV/dt transient immunity  $\pm 50$  V/ns
- Gate driving voltage range from 9 V to 20 V
- Overall input-output propagation delay: 85 ns
- Matched propagation delay for all channels
- 3.3 V, 5 V TTL/CMOS inputs with hysteresis
- Integrated bootstrap diodes
- Comparator for fast overcurrent protection
- Smart shutdown function
- Interlocking and deadtime function
- Dedicated Enable pin
- UVLO function on low-side and high-sides

### Applications

- 3-phase motor drives
- Inverters

### Description

The STDRIVE601 is a high voltage device manufactured with BCD6s offline technology. It is a single-chip with three half-bridge gate drivers for N-channel power MOSFETs or IGBTs suitable for 3-phase applications.

All device outputs can sink and source 350 mA and 200 mA respectively. Prevention from cross conduction is ensured by interlocking and deadtime function.

The device has dedicated input pins for each output and a shutdown pin. The logic inputs are CMOS/TTL compatible down to 3.3 V for easy interfacing with control devices. Matched delays between low-side and high-side sections guarantee no cycle distortion and allow high frequency operation.

The STDRIVE601 embeds a comparator featuring advanced SmartSD function also integrated in the device, ensuring fast and effective protection against fault events like overcurrent, overtemperature, etc.

Dedicated UVLO protection on the low-sides and each of the high-side driving sections allow to prevent the power switches from operating in low efficiency or dangerous conditions.

The integrated bootstrap diodes as well as all of the integrated features of this IC make the application PCB design easier, more compact and simpler, thus reducing the overall bill of material.

The device is available in SO-28 package.

#### Product status link

STDRIVE601

#### Product summary

Order code	STDRIVE601	STDRIVE601TR
Package	SO-28	
Packing	Tube	Tape & Reel

#### Product label



# 1 Block diagram

Figure 1. Block diagram

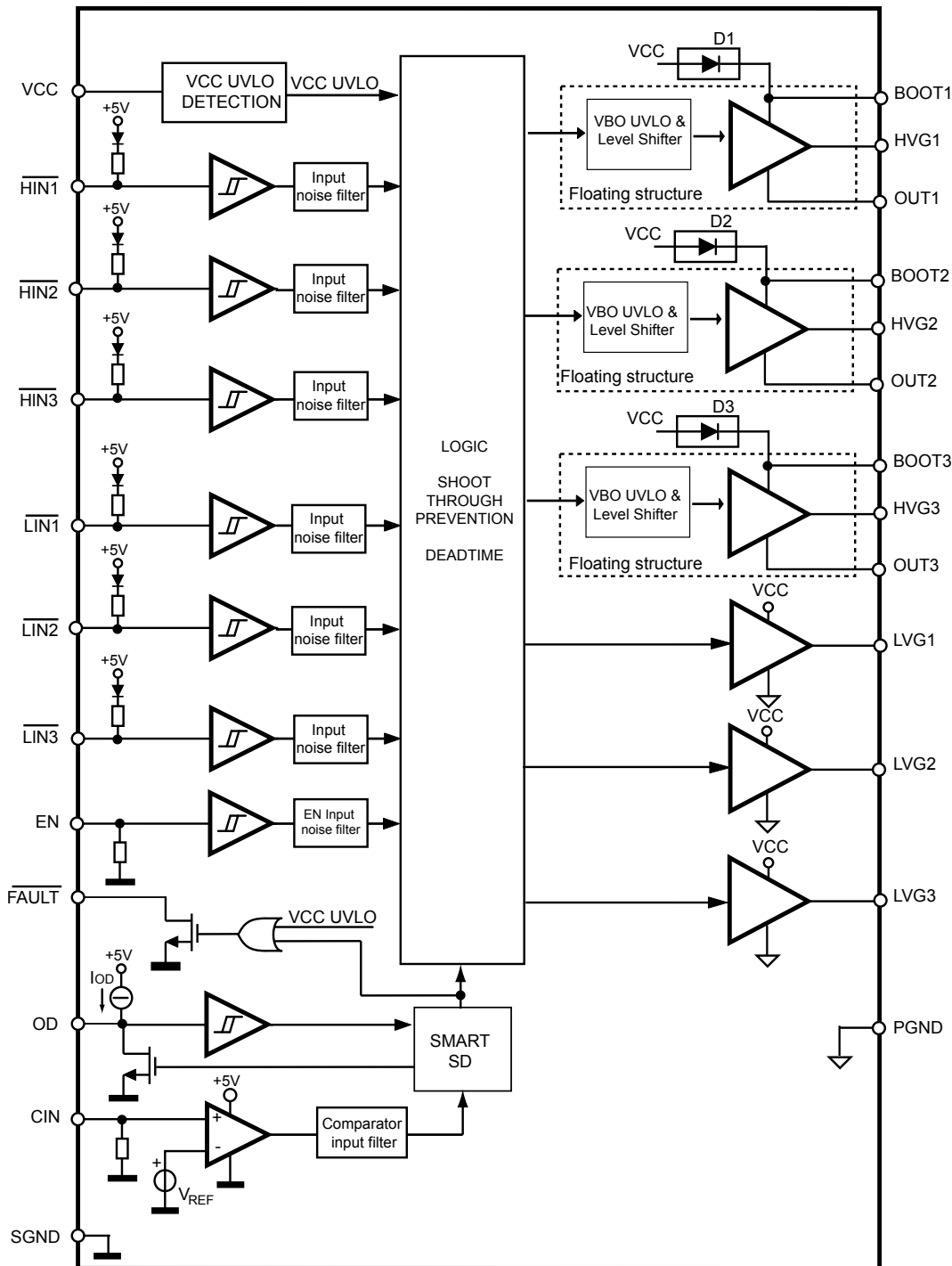

## 2 Pin description and connection diagram

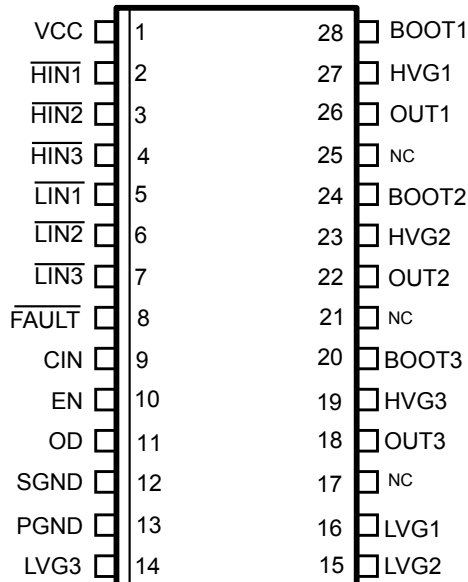
**Figure 2. Pin connection (top view)**

**Table 1. Pin description**

Pin #	Pin Name	Type	Function
1	VCC	Power Supply	Low-side and logic supply voltage
2	HIN1	Logic Input	High-side driver logic input 1
3	HIN2	Logic Input	High-side driver logic input 2
4	HIN3	Logic Input	High-side driver logic input 3
5	LIN1	Logic Input	Low-side driver logic input 1
6	LIN2	Logic Input	Low-side driver logic input 2
7	LIN3	Logic Input	Low-side driver logic input 3
8	FAULT	OD Output	Fault output
9	CIN	Analog Input	Comparator positive input
10	EN	Logic Input	Enable input, active high
11	OD	OD Output	SmartSD timing Open Drain output, unlatch and restart input
12	SGND	Power Supply	Signal ground
13	PGND	Power Supply	Low-side driver ground
14	LVG3 <sup>(1)</sup>	Analog Output	Low-side driver output 3
15	LVG2 <sup>(1)</sup>	Analog Output	Low-side driver output 2
16	LVG1 <sup>(1)</sup>	Analog Output	Low-side driver output 1
17, 21 25	N.C.	-	Not Connected
18	OUT3	Power Supply	High-side (floating) common voltage driver 3
19	HVG3 <sup>(1)</sup>	Analog Output	High-side driver output 3
20	BOOT3	Power Supply	Bootstrap supply voltage 3
22	OUT2	Power Supply	High-side (floating) common voltage driver 2



Pin #	Pin Name	Type	Function
23	HVG2 <sup>(1)</sup>	Analog Output	High-side driver output 2
24	BOOT2	Power Supply	Bootstrap supply voltage 2
26	OUT1	Power Supply	High-side (floating) common voltage driver 1
27	HVG1 <sup>(1)</sup>	Analog Output	High-side driver output 1
28	BOOT1	Power Supply	Bootstrap supply voltage 1

1. The circuit guarantees less than 1 V on the LVG and HVG pins (at  $I_{\text{sink}} = 10 \text{ mA}$ ), with  $V_{\text{CC}} > 3 \text{ V}$ . This allows omitting the "bleeder" resistor connected between the gate and the source of the external MOSFETs normally used to hold the pin low.



## 3 Electrical data

### 3.1 Absolute maximum ratings

**Table 2. Absolute maximum ratings**

Note: Each voltage referred to SGND unless otherwise specified.

Symbol	Parameter	Min.	Max.	Unit
VCC	Logic supply voltage	-0.3	21	V
V <sub>PGND</sub>	Low-side driver ground	VCC - 21	VCC + 0.3	V
V <sub>PS</sub> <sup>(1)</sup>	Low-side drivers ground	-21	21	V
V <sub>OUT</sub>	Output voltage	V <sub>BOOT</sub> - 21	V <sub>BOOT</sub> + 0.3	V
V <sub>BOOT</sub>	Bootstrap voltage	- 0.3	620	V
V <sub>HVG</sub>	High-side gate output voltage	V <sub>OUT</sub> - 0.3	V <sub>BOOT</sub> + 0.3	V
V <sub>LVG</sub>	Low-side gate output voltage	V <sub>PGND</sub> - 0.3	VCC + 0.3	V
V <sub>CIN</sub>	Comparator input voltage	- 0.3	20	V
V <sub>i</sub>	Logic input voltage <sup>(2)</sup>	- 0.3	15	V
V <sub>OD</sub>	OD pin voltage	- 0.3	21	V
V <sub>FAULT</sub>	FAULT pin voltage	- 0.3	21	V
dV <sub>OUT</sub> /dt	Common mode transient Immunity		50	V/ns
T <sub>J</sub>	Junction temperature	-40	150	°C
T <sub>S</sub>	Storage temperature	-50	150	°C
ESD	Human body model		2 <sup>(3)</sup>	kV

1. V<sub>PS</sub> = PGND - SGND.

2. EN, LINx, HINx.

3. Pins 18 to 28 have HBM ESD rating 1C conforming to ANSI/ESDA/JEDEC JS-001-2014.

### 3.2 Thermal data

**Table 3. Thermal data**

Symbol	Parameter	Value	Unit
R <sub>th(JA)</sub>	Thermal resistance junction to ambient <sup>(1)</sup>	52	°C/W

1. JEDEC 2s2p PCB in still air.



### 3.3 Recommended operating conditions

**Table 4. Recommended operating conditions**

Note: Each voltage referred to SGND unless otherwise specified.

Symbol	Parameter	Test conditions	Min.	Max.	Unit
VCC	Logic supply voltage	-	9	20	V
V <sub>LS</sub> <sup>(1)</sup>	Low-side drivers supply voltage	-	4	20	V
V <sub>PS</sub> <sup>(2)</sup>	Low-side drivers ground	-	-5	5	V
V <sub>BO</sub> <sup>(3)</sup>	Floating supply voltage <sup>(3)</sup>	-	8.5	20	V
V <sub>OUT</sub>	DC Output voltage	-	-10 <sup>(4)</sup>	580	V
V <sub>CIN</sub>	Comparator input voltage	-	0	15	V
V <sub>i</sub>	Logic input voltage	-	0	15	V
V <sub>OD</sub>	OD pin voltage	-	0	20	V
V <sub>FAULT</sub>	FAULT pin voltage	-	0	20	V
F <sub>SW</sub> <sup>(5)</sup>	Maximum switching frequency	-	-	800	kHz
PW <sup>(6)</sup>	Minimum input pulse width	-	100	-	ns
T <sub>J</sub>	Junction temperature	-	-40	125	°C

1.  $V_{LS} = VCC - PGND$
2.  $V_{PS} = PGND - SGND$ .
3.  $V_{BO} = BOOT - OUT$ .
4.  $VCC = 9\text{ V}$ , LVG off. Logic is operational if  $V_{BOOT} > 5\text{ V}$ .
5. Actual maximum  $F_{SW}$  depends on power dissipation.
6. Pulse width on LIN or HIN pins. See Figure 3. Propagation delay timing definition.



## 4 Electrical characteristics

**Table 5. Electrical characteristics**

Note:  $V_{CC} = 15\text{ V}$ ;  $P_{GND} = SGND$ ;  $T_J = +25\text{ }^\circ\text{C}$ , unless otherwise specified. HIN is referred to channels HIN1, HIN2, HIN3; LIN is referred to channels LIN1, LIN2, LIN3.

Symbol	Pin	Parameter	Test conditions	Min.	Typ.	Max.	Unit
Low-side section supply							
$V_{CC_{THON}}$		VCC UVLO turn-on threshold	-	8	8.5	9	V
$V_{CC_{THOFF}}$		VCC UVLO turn-off threshold	-	7.5	8	8.5	V
$V_{CC_{HYS}}$		VCC UVLO hysteresis	-	0.4	0.5	0.6	V
$I_{QCCU}$		VCC undervoltage quiescent supply current	$V_{CC} = 7\text{ V}$ ; $EN = 5\text{ V}$ ; $CIN = SGND$ LVG & HVG: OFF	-	430	744	$\mu\text{A}$
$I_{QCC}$		VCC quiescent supply current	$EN = 5\text{ V}$ ; $CIN = SGND$ LVG & HVG: OFF	-	950	1450	$\mu\text{A}$
High-side floating section supply <sup>(1)</sup>							
$V_{BOTHON}$	20 - 18 24 - 22 28 - 26	$V_{BO}$ UVLO turn-on threshold	-	7.5	8	8.5	V
$V_{BOTHOFF}$		$V_{BO}$ UVLO turn-off threshold	-	7	7.5	8	V
$V_{BO_{HYS}}$		$V_{BO}$ UVLO hysteresis	-	0.4	0.5	0.6	V
$I_{QBOU}$		$V_{BO}$ undervoltage quiescent supply current	$V_{CC} = V_{BO} = 6.5\text{ V}$ ; $EN = 5\text{ V}$ ; $CIN = SGND$ LVG OFF; HVG = ON	-	25	62	$\mu\text{A}$
$I_{QBO}$		$V_{BO}$ quiescent supply current	$V_{BO} = 15\text{ V}$ $EN = 5\text{ V}$ ; $CIN = SGND$ LVG OFF; HVG = ON	-	84	150	$\mu\text{A}$
$I_{LK}$	-	High voltage leakage current	BOOT = HVG = OUT = 620V	-	-	15	$\mu\text{A}$
$R_{Dboot}$	-	Bootstrap Diode on resistance	-	-	215	-	$\Omega$
Output driving buffers							
$I_{SO}$		High/Low-side source peak current	$T_J = 25\text{ }^\circ\text{C}$	160	200	300	mA
			Full temperature range <sup>(2)</sup>	130	-	350	-
$I_{SI}$	14, 15, 16, 19, 23, 27	High/Low-side sink peak current	$T_J = 25\text{ }^\circ\text{C}$	230	350	430	mA
			Full temperature range <sup>(2)</sup>	200	-	500	-
$R_{DSonON}$		High/Low-side source $R_{DSon}$	$I = 10\text{ mA}$	24	35	46	$\Omega$
$R_{DSonOFF}$		High/Low-side sink $R_{DSon}$	$I = 10\text{ mA}$	11	16	21	$\Omega$
Logic Inputs							
$V_{il}$	2, 3, 4, 5, 6, 7, 10	Low level logic threshold voltage	-	0.8	-	1.4	V
$V_{ih}$		High level logic threshold voltage	-	1.8	-	2.3	V
$V_{hyst}$	2, 3, 4, 5, 6, 7, 10	Logic input threshold hysteresis	-	0.8	-	1.2	V
$V_{SSDh}$	11	SmartSD restart threshold	-	3.5	4	4.3	V
$V_{SSDI}$		SmartSD unlatch threshold	-	-	0.56	0.75	V
$I_{LINh}$	5, 6, 7	LIN logic "1" input bias current	$V_{LINx} = 15\text{ V}$	-	-	1	$\mu\text{A}$
$I_{LINl}$		LIN logic "0" input bias current	$V_{LINx} = 0\text{ V}$	28	43	58	$\mu\text{A}$



Symbol	Pin	Parameter	Test conditions	Min.	Typ.	Max.	Unit	
$I_{HINh}$	2, 3, 4	HIN logic "1" input bias current	$V_{HINx} = 15\text{ V}$	-	-	1	$\mu\text{A}$	
$I_{HINl}$		HIN logic "0" input bias current	$V_{HINx} = 0$	28	43	58	$\mu\text{A}$	
$R_{PU\_IN}$	2, 3, 4, 5, 6, 7	Logic input pull-up resistor	-	75	100	125	$\text{k}\Omega$	
$I_{ENh}$	10	EN logic "1" input bias current	$V_{EN} = 15\text{ V}$	110	150	200	$\mu\text{A}$	
$I_{ENl}$		EN logic "0" input bias current	$V_{EN} = 0\text{ V}$	-	-	1	$\mu\text{A}$	
$R_{PD\_EN}$	10	EN pull-down resistor	-	75	100	125	$\text{k}\Omega$	
<b>Sense comparator<sup>(3)</sup> and FAULT</b>								
$V_{REF}$	-	Internal voltage reference	-	410	460	510	mV	
$C_{INhyst}$	9	Comparator input hysteresis	-	40	70	-	mV	
$C_{IN\_PD}$	9	Comparator input pull- down current	$V_{CIN} = 1\text{ V}$	7	10	13	$\mu\text{A}$	
$I_{OD}$	11	OD internal current source	-	2.5	5	7.5	$\mu\text{A}$	
$R_{ON\_OD}$	11	OD On resistance	$I_{OD} = 16\text{ mA}$	19	25	36	$\Omega$	
$I_{OL\_OD}$	11	OD low level sink current	$V_{OD} = 400\text{ mV}$	11	16	21	mA	
$I_{SAT\_OD}$	11	OD saturation current	$V_{OD} = 5\text{ V}$	-	95	-	mA	
$V_{FLOAT\_OD}$	11	OD floating voltage level	OD connected only to an external capacitance	4.4	4.8	5.2	V	
$R_{ON\_F}$	8	FAULT ON resistance	$I_{FAULT} = 8\text{ mA}$	-	50	100	$\Omega$	
$I_{OL\_F}$	8	FAULT low level sink current	$V_{FAULT} = 400\text{ mV}$	4	8	12	mA	
$t_{OD}$	11	Comparator propagation delay	$R_{pu} = 100\text{ k}\Omega$ to 5 V; voltage step on $C_{IN} = 0$ to 3.3 V; 50% $C_{IN}$ to 90% OD	-	350	500	ns	
$t_{CIN-F}$	11	Comparator triggering to FAULT	voltage step on $C_{IN} = 0$ to 3.3 V; 50% $C_{IN}$ to 90% FAULT	-	350	500	ns	
$t_{CINoff}$	11	Comparator triggering to high/low-side driver propagation delay	voltage step on $C_{IN} = 0$ to 3.3 V; 50% $C_{IN}$ to 90% LVG/HVG	-	360	510	ns	
$t_{FCIN}$	11	Comparator input filter time	-	200	300	400	ns	
SR	11	OD Slew rate	$C_L = 1\text{ nF}$ ; $R_{pu} = 33\text{ k}\Omega$ to 5 V; 90% to 10% OD	20	60	100	V/ $\mu\text{s}$	
<b>Dynamic characteristics</b>								
$t_{on}$	2 vs. 27 vs 23 vs 19	High/Low-side driver turn-on propagation delay	OUT = 0 V BOOT = VCC $C_L = 1\text{ nF}$ Vin = 0 to 3.3 V	45	85	120	ns	
$t_{off}$	5 vs. 16 6 vs. 15 7 vs. 14	High/Low-side driver turn-off propagation delay		45	85	120	ns	
$t_{EN}$	10 vs. 14, 15, 16, 19, 23, 27	Enable to high/low- side driver propagation delay		245	385	520	ns	
$t_{FIN}$	2,3,4, 5,6,7	LIN HIN input filter time		-	30	40	50	ns
$t_{FEN}$	10	EN input filter time		-	200	300	400	ns



Symbol	Pin	Parameter	Test conditions	Min.	Typ.	Max.	Unit
$t_r$	14, 15, 16, 19, 23, 27	Rise time	$C_L = 1\text{ nF}$	-	120	160	ns
$t_f$		Fall time	$C_L = 1\text{ nF}$	-	50	75	ns
MT	-	Delay matching high/low side turn-on/off <sup>(4)</sup>	-	-	0	30	ns
DT	-	Deadtime	$C_L = 1\text{ nF}$	200	300	400	ns
MDT	-	Matching deadtime <sup>(5)</sup>	$C_L = 1\text{ nF}$	-	0	50	ns

- $V_{BO} = \text{BOOT} - \text{OUT}$ .
- Values provided by characterization, not tested.
- Comparator is disabled when VCC is in UVLO condition.
- $MT = \max. (|t_{on}(LVG) - t_{off}(LVG)|, |t_{on}(HVG) - t_{off}(HVG)|, |t_{off}(LVG) - t_{on}(HVG)|, |t_{off}(HVG) - t_{on}(LVG)|)$ .
- $MDT = |DT_{LH} - DT_{HL}|$ , refer to Section 4 Electrical characteristics

**Figure 3. Propagation delay timing definition**

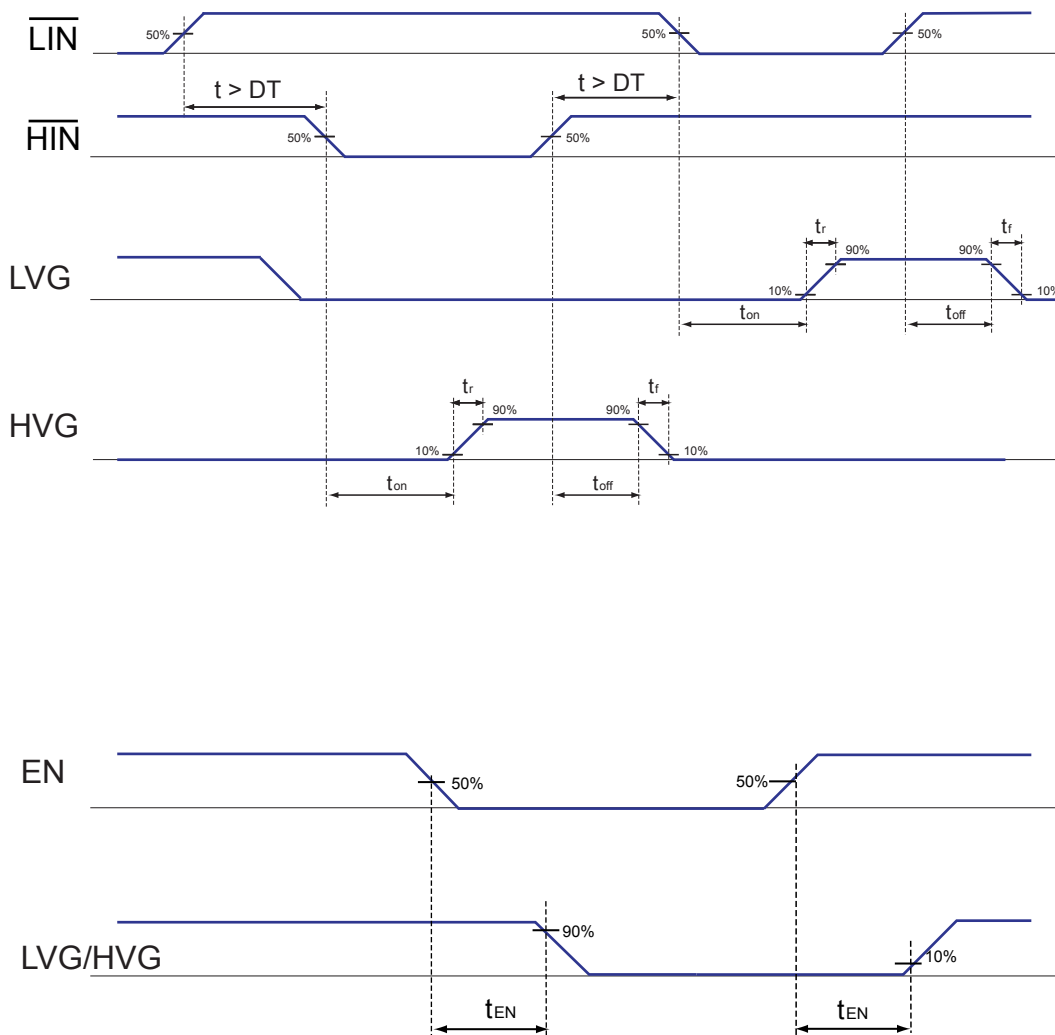

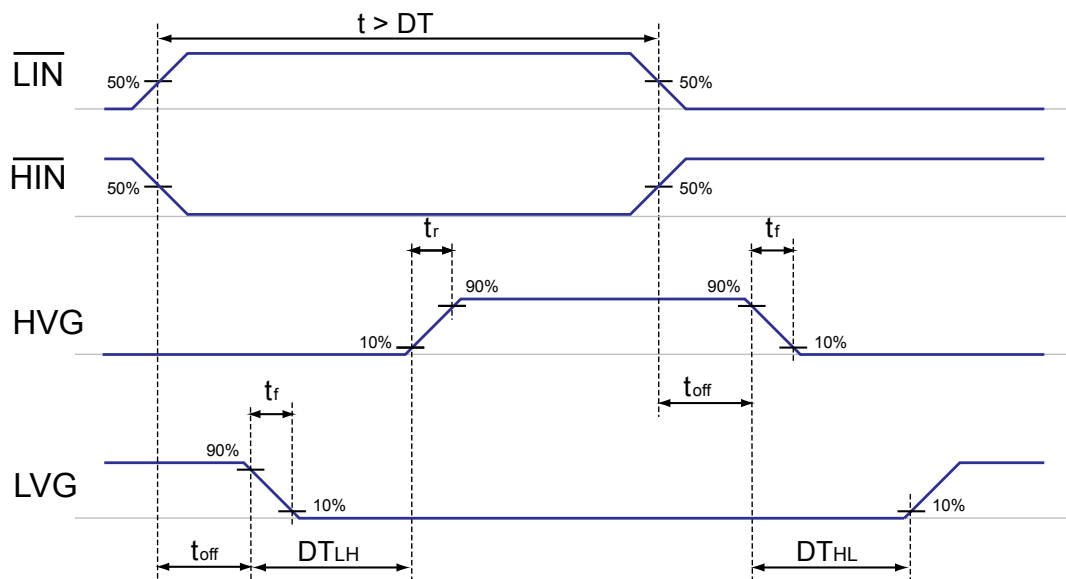
**Figure 4. Deadtime timing definitions**



**Figure 5. Deadtime and interlocking waveforms definition**

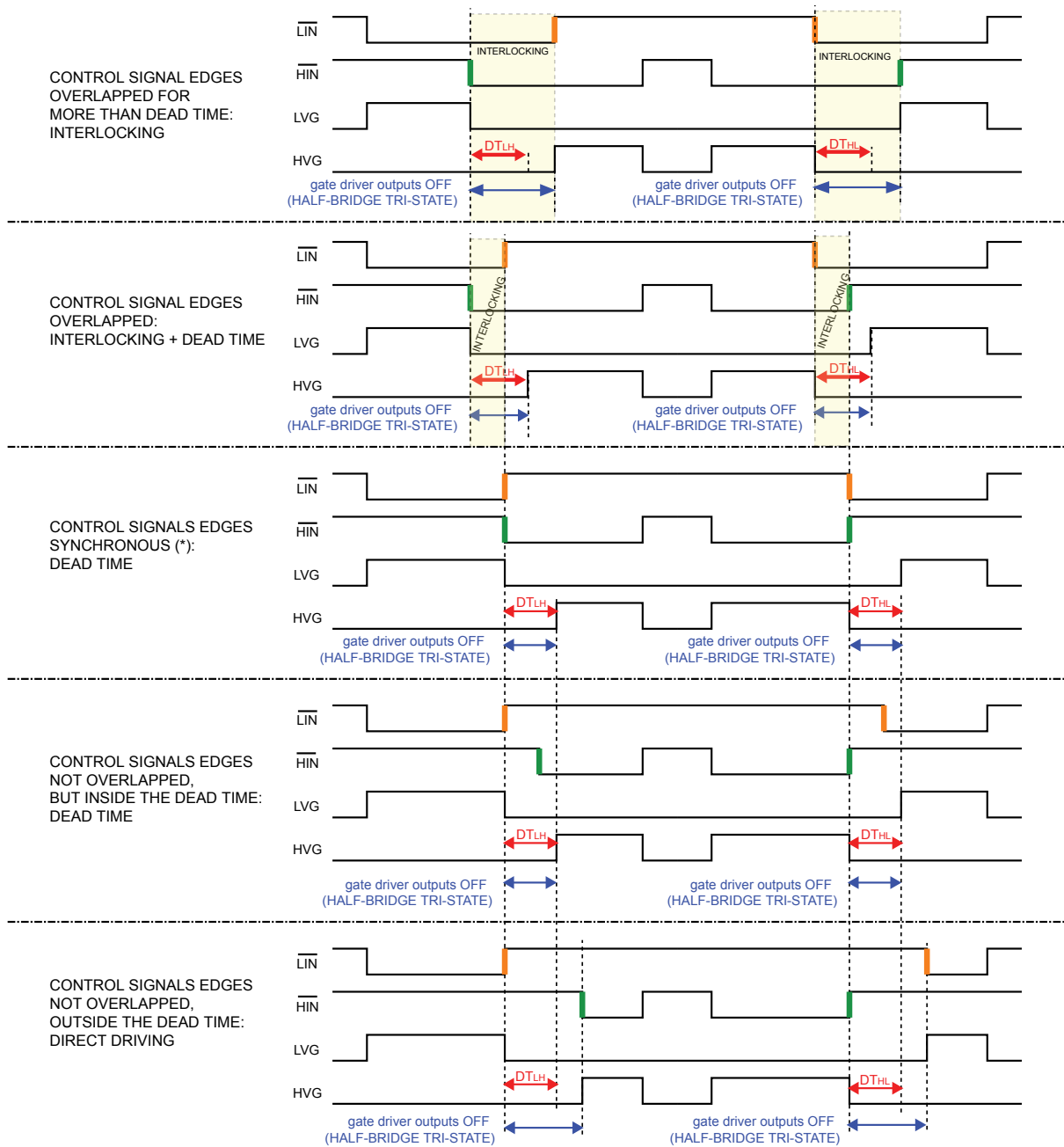



## 5 Functional description

### 5.1 Inputs and outputs

The devices are controlled through the following logic inputs:

- EN: Enable input, active high;
- LIN: low-side driver inputs, active low;
- HIN: high-side driver inputs, active low.

**Table 6. Inputs truth table**

Note: Applicable when device is not in UVLO or SmartSD protection

Input pins			Output pins	
EN	LIN	HIN	LVG	HVG
L	X	X	Low	Low
H	H	H	Low	Low
H	L	H	High	Low
H	H	L	Low	High
<b>Interlocking</b>				
H	L	L	Low	Low

The FAULT and OD pins are open-drain outputs.

The FAULT signal is set low in case VCC UVLO is detected, or in case the SmartShutDown comparator triggers an event. It is only used to signal a UVLO or SmartSD activation to external circuits, and its state does not affect the behavior of other functions or circuits inside the driver. The OD behavior is explained in [Section 5.5 Comparator and smart shutdown](#).

When EN is set low, gate driver outputs are forced low and assure low impedance.

### 5.2 Deadtime

The deadtime feature, in companion with interlocking feature, guarantees that driver outputs of the same channel are not high simultaneously and at least a DT time passes between the turn-off of one driver's output and the turn-on of the companion output of the same channel. If a deadtime longer than the internal DT is applied to LIN and HIN inputs by the external controller, the internal DT is ignored, and the outputs follow the deadtime determined by the inputs.

Refer to [Figure 4. Deadtime timing definitions](#) for the dead time and interlocking waveforms.

### 5.3 VCC UVLO protection

Undervoltage protection is available on VCC and BOOT supply pins. In order to avoid intermittent operation, a hysteresis set the turn-off threshold with respect to the turn-on threshold.

When VCC voltage goes below  $V_{CC\_THOFF}$  threshold all the outputs are switched off, both LVG and HVG. When VCC voltage reaches  $V_{CC\_THON}$  threshold the driver returns to normal operation and sets the LVG outputs according to actual input pins status; HVG is also set according to input pin status if the corresponding  $V_{BO}$  section is not in UVLO condition.

The FAULT output is kept low when VCC is in UVLO condition. The following figures show some examples of typical operation conditions.

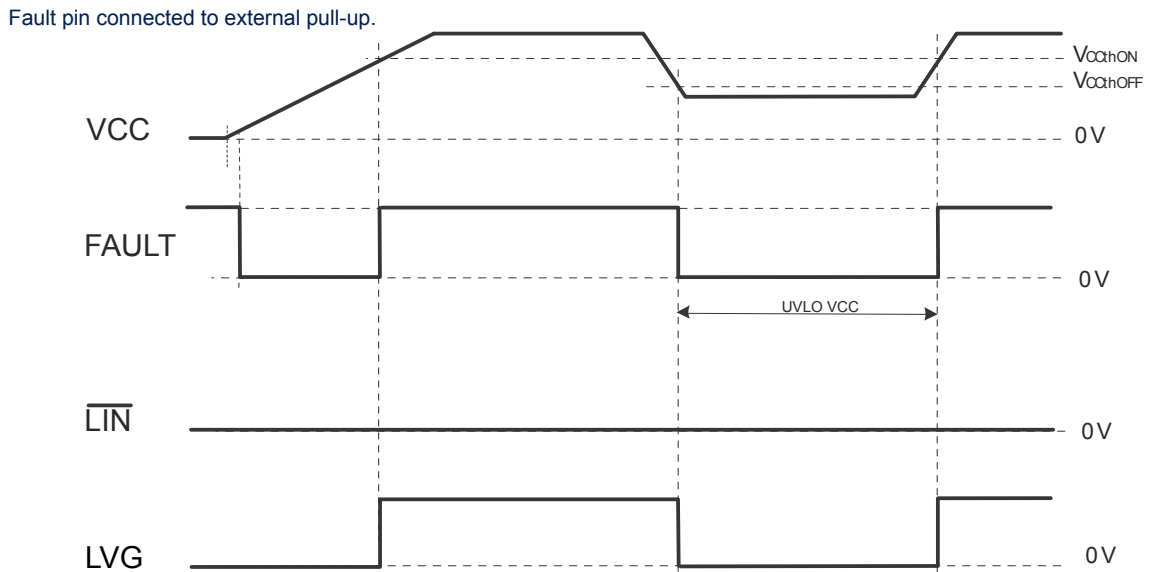
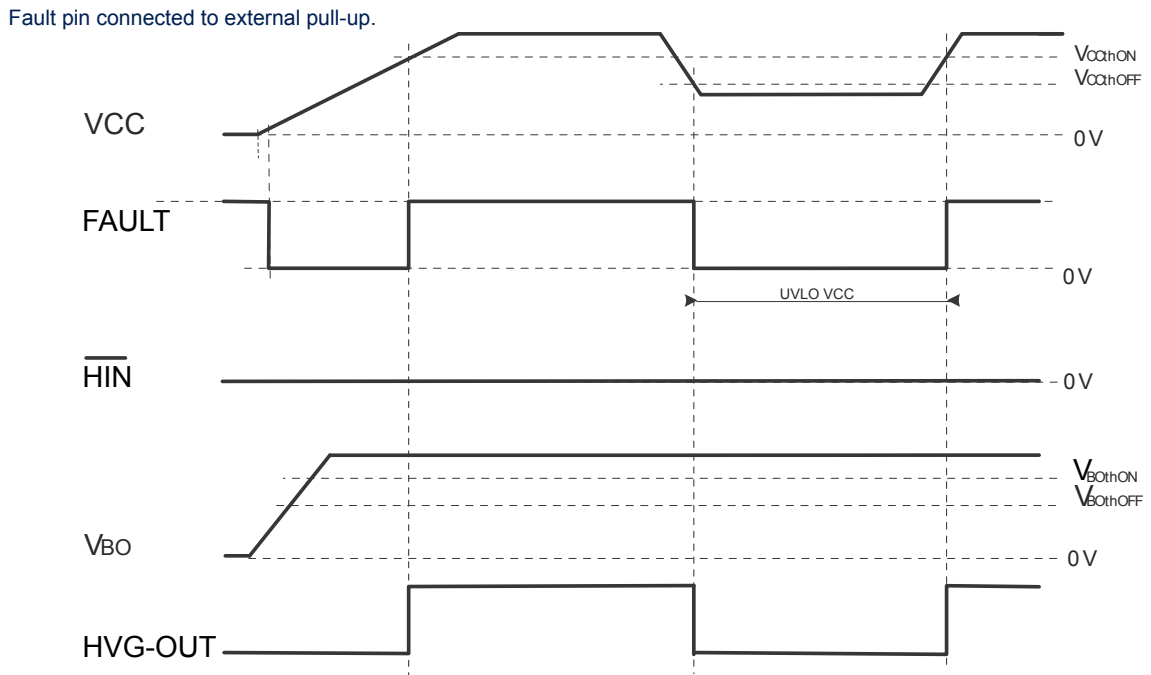
**Figure 6. VCC power ON and UVLO, LVG timing**

**Figure 7. VCC power ON and UVLO, HVG timing**

## 5.4

### VBO UVLO protection

Dedicated undervoltage protection is available on each bootstrap section between BOOTx and OUTx supply pins. In order to avoid intermittent operation, a hysteresis sets the turn-off threshold with respect to the turn-on threshold.

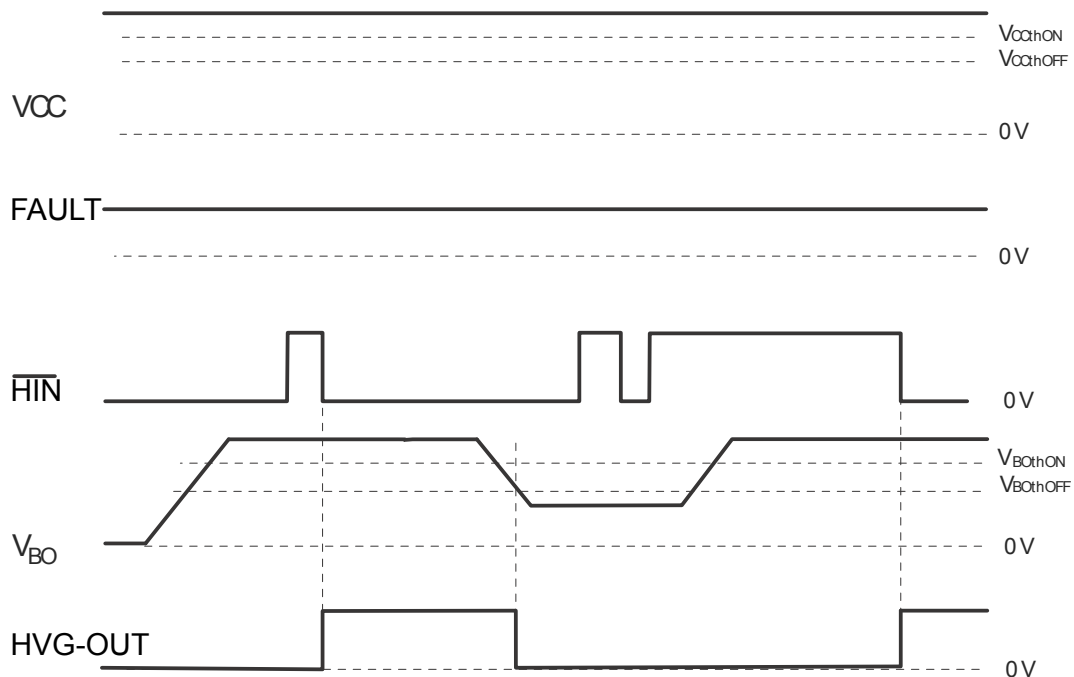
When  $V_{\text{BO}}$  voltage goes below  $V_{\text{BOthOFF}}$  threshold, the HVG output of corresponding bootstrap section is switched off. When  $V_{\text{BO}}$  voltage reaches  $V_{\text{BOthON}}$  threshold device returns to normal operation and the output remains off up to the next input pins transition that requests HVG to turn on.

**Figure 8.  $V_{BO}$  power-ON and UVLO timing**

## 5.5 Comparator and smart shutdown

This device integrates a comparator committed to the fault protection function, thanks to the SmartShutDown (SmartSD) circuit.

The SmartSD architecture allows immediate turn-off of the gate driver outputs in the case of overload or overcurrent condition, by minimizing the propagation delay between the fault detection event and the actual output switch-off. In fact, the time delay between the fault detection and the output turn-off is not dependent on the value of the external components connected to the OD pin, which are only used to set the duration of disable time after the fault.

This provides the possibility to increase the duration of the *output disable time* after the fault event up to very large values without increasing the delay time of the protection. The duration of the disable time is determined by the values of the external capacitor  $C_{OD}$  and of the optional pull-up resistor connected to OD pin.

The comparator has an internal voltage reference  $V_{REF}$  connected to the inverting input, while the non-inverting input is available on the CIN pin. The comparator CIN input can be connected to an external shunt resistor in order to implement a fast and simple overcurrent protection function. The output signal of the comparator is filtered from glitches shorter than  $t_{FCIN}$  and then fed to the SmartSD logic.

If the impulse on CIN pin is higher than  $V_{REF}$  and wider than  $t_{FCIN}$ , the SmartSD logic is triggered and immediately sets all of the driver outputs to low-level (OFF).

At the same time, FAULT is forced low to signal the event (for example to an MCU input) and OD starts to discharge the external  $C_{OD}$  capacitor used to set the duration of the output disable time of the fault event.

The FAULT pin is released and driver outputs restart following the input pins as soon as the *output disable time* expires.

The overall disable time is composed of two phases:

- The *OD unlatch time* ( $t_1$  in [Figure 9. Smart shutdown timing waveforms](#)), which is the time required to discharge  $C_{OD}$  capacitor down to  $V_{SSDI}$  threshold. The discharge starts as soon as the SmartSD comparator is triggered.
- The *OD restart time* ( $t_2$  in [Figure 9. Smart shutdown timing waveforms](#)), which is the time required to recharge the  $C_{OD}$  capacitor up to the  $V_{SSDh}$  threshold. The recharge of  $C_{OD}$  starts when the OD internal MOSFET is turned-off, which happens when the fault condition has been removed ( $CIN < V_{REF} - C_{INhyst}$ ) and the voltage on OD reaches the  $V_{SSDI}$  threshold. This time normally covers most of the overall output disable time.



If no external pull-up is connected to OD, the external  $C_{OD}$  capacitor is discharged with a time constant defined by  $C_{OD}$  and the internal MOSFET's characteristic (Eq. (1)), and the *Restart time* is determined by the internal current source  $I_{OD}$  and by  $C_{OD}$  (Eq. (2)).

$$t_1 \cong R_{ON\_OD} \cdot C_{OD} \cdot \ln\left(\frac{V_{OD}}{V_{SSDI}}\right) \quad (1)$$

$$t_2 \cong \frac{C_{OD} \cdot V_{SSDh}}{I_{OD}} \cdot \ln\left(\frac{V_{SSDI} - V_{OD}}{V_{SSDh} - V_{OD}}\right) \quad (2)$$

In case the OD pin is connected to VCC by an external pull-up resistor  $R_{OD\_ext}$ , the OD discharge time is determined by the external network  $R_{OD\_ext}$   $C_{OD}$  and by the internal MOSFET's  $R_{ON\_OD}$  (Eq. (3)), while the *Restart time* is determined by current in  $R_{OD\_ext}$  (Eq. (4)).

$$t_1 \cong C_{OD} \cdot (R_{OD\_ext} // R_{ON\_OD}) \cdot \ln\left(\frac{V_{OD} - V_{on}}{V_{SSDI} - V_{on}}\right) \quad (3)$$

$$t_1 \cong C_{OD} \cdot R_{OD\_ext} \cdot \ln\left(\frac{V_{SSDI} - V_{OD}}{V_{SSDh} - V_{OD}}\right) \quad (4)$$

Where:

$$V_{on} = \frac{R_{ON\_OD}}{R_{ON\_ext} + R_{ON\_OD}} \cdot V_{OD} = V_{CC}$$



**Figure 9. Smart shutdown timing waveforms**

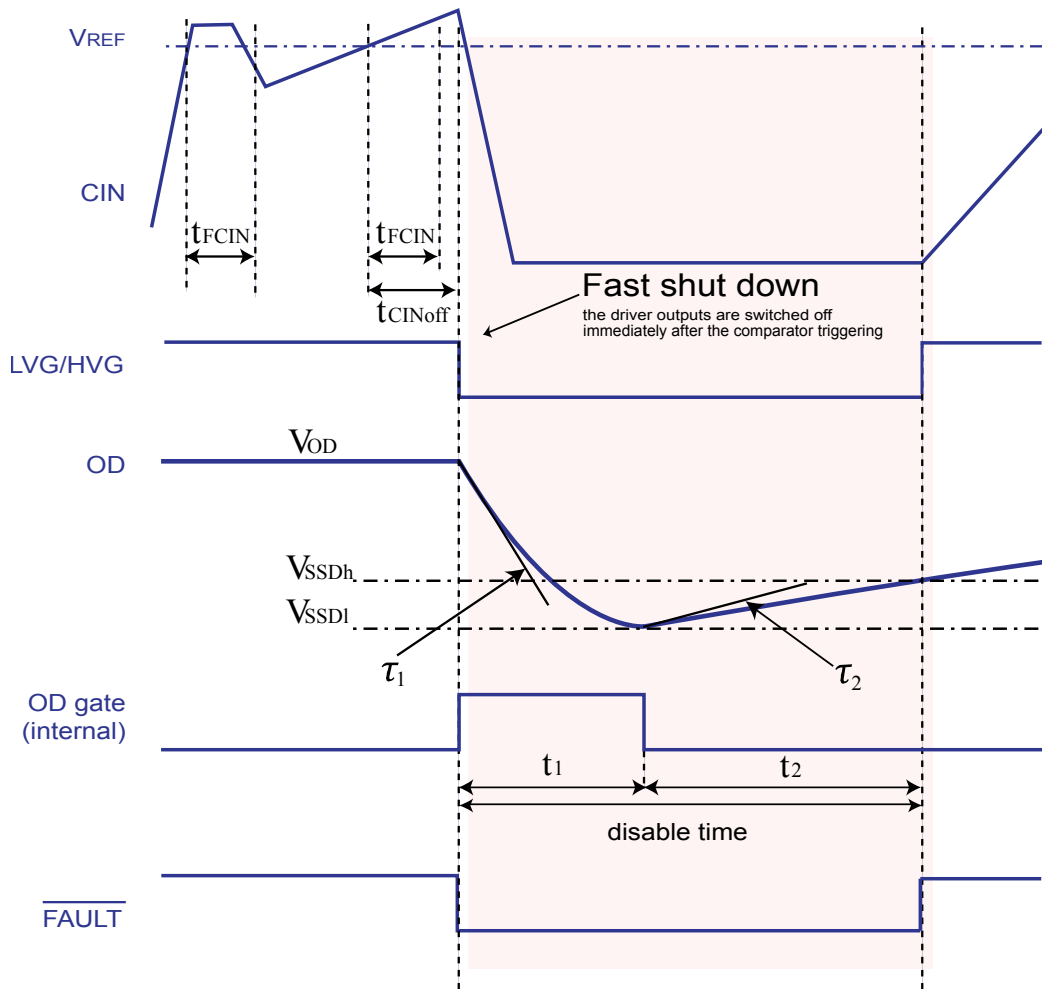

**SMART SHUTDOWN CIRCUIT**

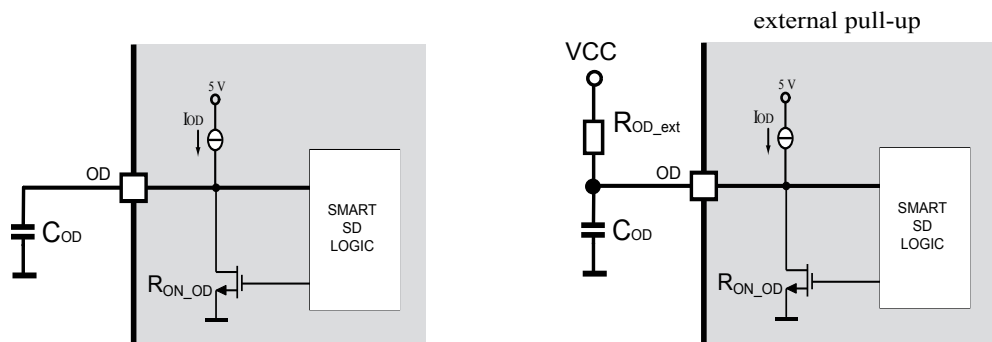

**6 Typical application diagram**

Figure 10. Typical application diagram

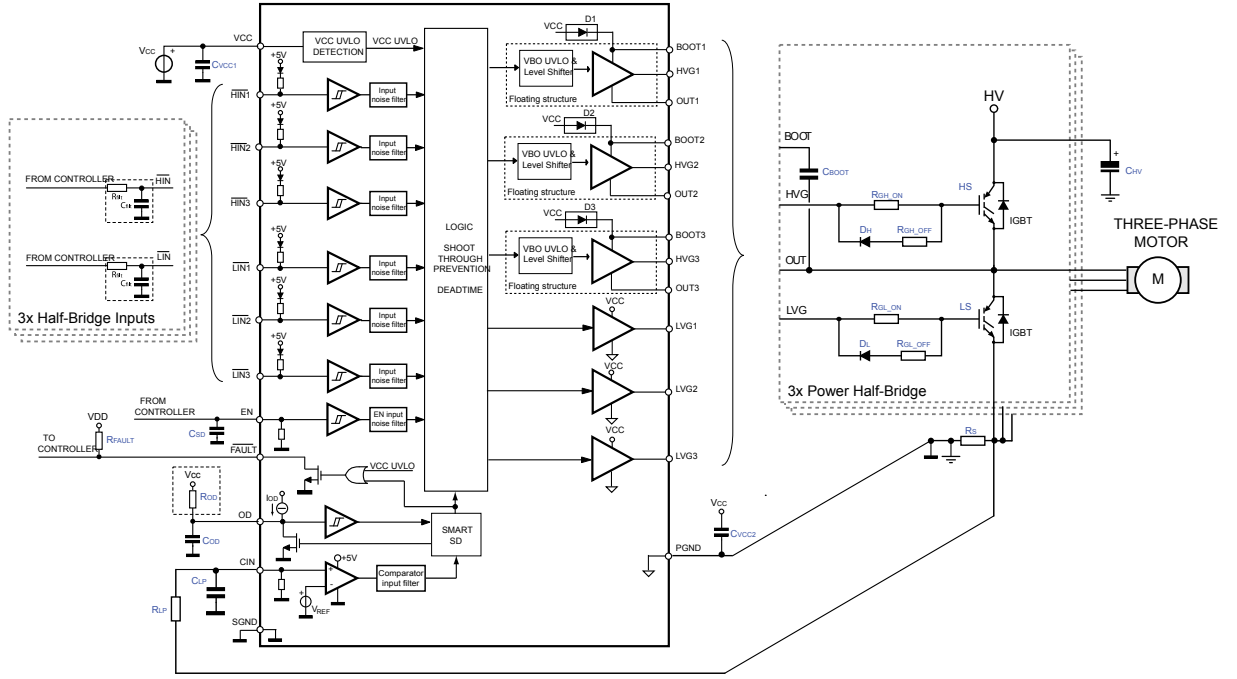



## 7 Package information

In order to meet environmental requirements, ST offers these devices in different grades of **ECOPACK** packages, depending on their level of environmental compliance. ECOPACK specifications, grade definitions and product status are available at: [www.st.com](http://www.st.com). ECOPACK is an ST trademark.

### 7.1 SO-28 package information

**Table 7. SO-28 package dimensions**

Dim.	Mm		
	Min.	Typ.	Max.
A	2.35	-	2.65
A1	0.10	-	0.30
B	0.33	-	0.51
C	0.23	-	0.32
D	17.70	-	18.10
E	7.40	-	7.60
e	-	1.27	-
H	10.00	-	10.65
h	0.25	-	0.75
L	0.40	-	1.27
k	0°	-	8°
ddd	-	-	0.10



Figure 11. SO-28 mechanical data

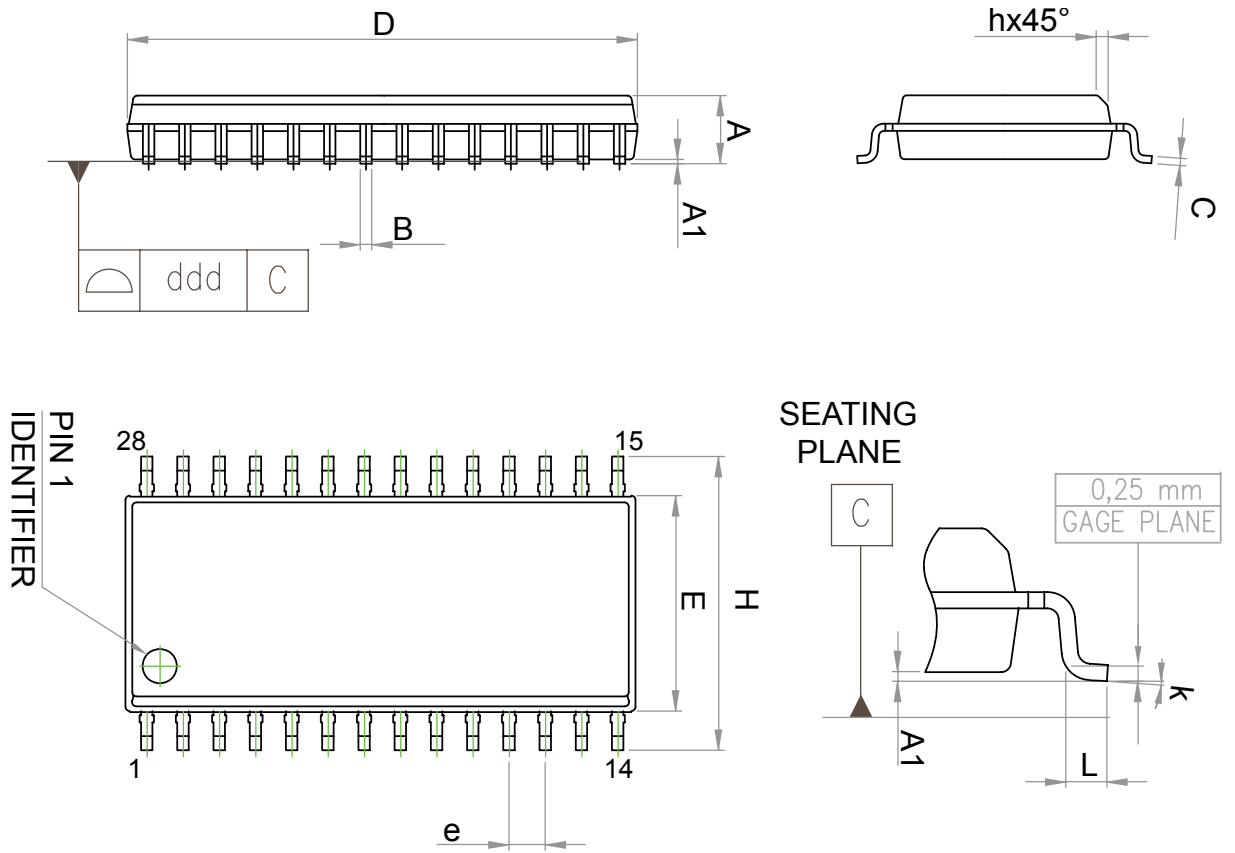
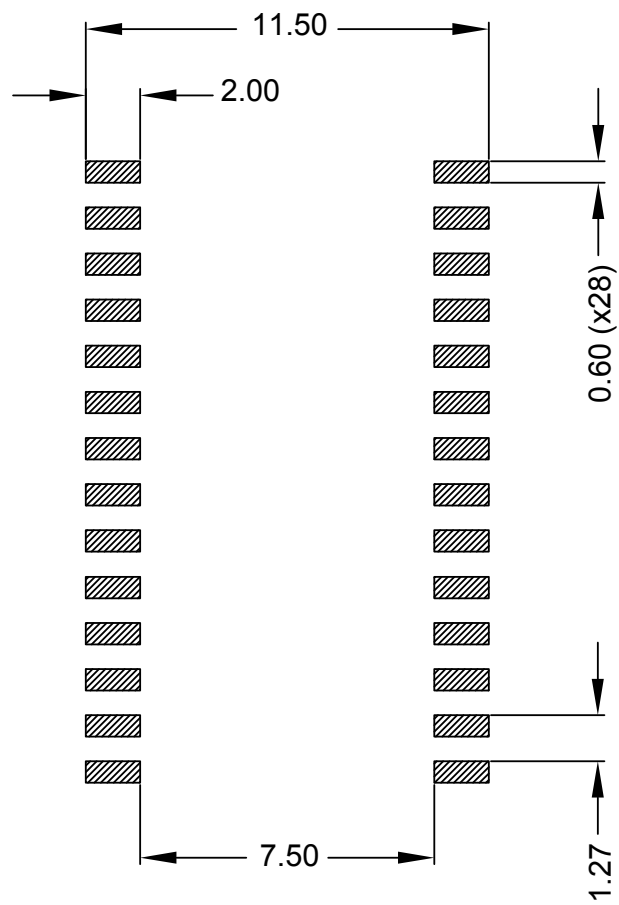

Figure 12. SO-28 suggested land pattern





## 8 Ordering information

**Table 8. Order codes**

Order code	Package	Package marking	Packaging
STDRIVE601	SO-28	STDRV601	Tube
STDRIVE601TR	SO-28	STDRV601	Tape and reel



## Revision history

**Table 9. Document history**

Date	Revision	Changes
21-May-2019	1	Initial release.
02-Apr-2021	2	Throughout document: - updated template - minor text edits In Table 2. Absolute maximum ratings: - updated ESD value and added footnote In Table 5. Electrical characteristics: - updated $V_{SSDh}$ Typ. and Max. values - updated $V_{FLOAT\_OD}$ Min., Typ., and Max. values



## Contents

<b>1</b>	<b>Block diagram</b> .....	<b>2</b>
<b>2</b>	<b>Pin description and connection diagram</b> .....	<b>3</b>
<b>3</b>	<b>Electrical data</b> .....	<b>5</b>
<b>3.1</b>	Absolute maximum ratings .....	5
<b>3.2</b>	Thermal data .....	5
<b>3.3</b>	Recommended operating conditions .....	6
<b>4</b>	<b>Electrical characteristics</b> .....	<b>7</b>
<b>5</b>	<b>Functional description</b> .....	<b>12</b>
<b>5.1</b>	Inputs and outputs .....	12
<b>5.2</b>	Deadtime .....	12
<b>5.3</b>	VCC UVLO protection .....	12
<b>5.4</b>	VBO UVLO protection .....	13
<b>5.5</b>	Comparator and smart shutdown .....	14
<b>6</b>	<b>Typical application diagram</b> .....	<b>17</b>
<b>7</b>	<b>Package information</b> .....	<b>18</b>
<b>7.1</b>	SO-28 package information .....	18
<b>8</b>	<b>Ordering information</b> .....	<b>21</b>
	<b>Revision history</b> .....	<b>22</b>



## List of figures

<b>Figure 1.</b>	Block diagram . . . . .	2
<b>Figure 2.</b>	Pin connection (top view) . . . . .	3
<b>Figure 3.</b>	Propagation delay timing definition . . . . .	9
<b>Figure 4.</b>	Deadtime timing definitions . . . . .	10
<b>Figure 5.</b>	Deadtime and interlocking waveforms definition . . . . .	11
<b>Figure 6.</b>	VCC power ON and UVLO, LVG timing . . . . .	13
<b>Figure 7.</b>	VCC power ON and UVLO, HVG timing . . . . .	13
<b>Figure 8.</b>	V <sub>BO</sub> power-ON and UVLO timing . . . . .	14
<b>Figure 9.</b>	Smart shutdown timing waveforms . . . . .	16
<b>Figure 10.</b>	Typical application diagram . . . . .	17
<b>Figure 11.</b>	SO-28 mechanical data . . . . .	19
<b>Figure 12.</b>	SO-28 suggested land pattern . . . . .	20



## List of tables

<b>Table 1.</b>	Pin description . . . . .	3
<b>Table 2.</b>	Absolute maximum ratings . . . . .	5
<b>Table 3.</b>	Thermal data . . . . .	5
<b>Table 4.</b>	Recommended operating conditions . . . . .	6
<b>Table 5.</b>	Electrical characteristics . . . . .	7
<b>Table 6.</b>	Inputs truth table . . . . .	12
<b>Table 7.</b>	SO-28 package dimensions . . . . .	18
<b>Table 8.</b>	Order codes . . . . .	21
<b>Table 9.</b>	Document history . . . . .	22

**IMPORTANT NOTICE – PLEASE READ CAREFULLY**

STMicroelectronics NV and its subsidiaries (“ST”) reserve the right to make changes, corrections, enhancements, modifications, and improvements to ST products and/or to this document at any time without notice. Purchasers should obtain the latest relevant information on ST products before placing orders. ST products are sold pursuant to ST’s terms and conditions of sale in place at the time of order acknowledgement.

Purchasers are solely responsible for the choice, selection, and use of ST products and ST assumes no liability for application assistance or the design of Purchasers’ products.

No license, express or implied, to any intellectual property right is granted by ST herein.

Resale of ST products with provisions different from the information set forth herein shall void any warranty granted by ST for such product.

ST and the ST logo are trademarks of ST. For additional information about ST trademarks, please refer to [www.st.com/trademarks](http://www.st.com/trademarks). All other product or service names are the property of their respective owners.

Information in this document supersedes and replaces information previously supplied in any prior versions of this document.

© 2021 STMicroelectronics – All rights reserved

## OUR CERTIFICATE

DiGi provide top-quality products and perfect service for customer worldwide through standardization, technological innovation and continuous improvement. DiGi through third-party certification, we stricly control the quality of products and services. Welcome your RFQ to

Email: [Info@DiGi-Electronics.com](mailto:Info@DiGi-Electronics.com)



Tel: +00 852-30501935

RFQ Email: [Info@DiGi-Electronics.com](mailto:Info@DiGi-Electronics.com)

DiGi is a global authorized distributor of electronic components.