

# STL9P3LLH6 Datasheet

[www.digi-electronics.com](http://www.digi-electronics.com)

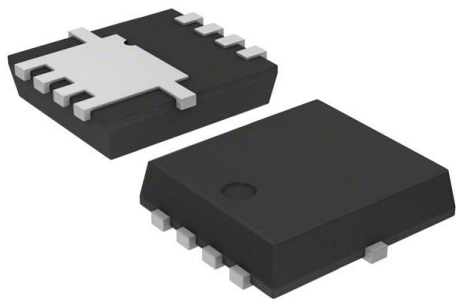

<https://www.DiGi-Electronics.com>

DiGi Electronics Part Number	STL9P3LLH6-DG
Manufacturer	<a href="#">STMicroelectronics</a>
Manufacturer Product Number	STL9P3LLH6
Description	MOSFET P-CH 30V 9A POWERFLAT
Detailed Description	P-Channel 30 V 9A (Tc) 3W (Ta) Surface Mount PowerFlat™ (3.3x3.3)

This model STL9P3LLH6 is available at DiGi Electronics.

DiGi Electronics offers a global database of semiconductor and electronic component datasheets.

We welcome your inquiries regarding pricing, lead time, or other product-related questions.

 [Request a Quote](#)

 [Datasheet Search](#)



Tel: +00 852-30501935

RFQ Email: [Info@DiGi-Electronics.com](mailto:Info@DiGi-Electronics.com)

DiGi is a global authorized distributor of electronic components.

## Purchase and inquiry

Manufacturer Product Number:

STL9P3LLH6

Series:

STripFET™ H6

FET Type:

P-Channel

Drain to Source Voltage (Vdss):

30 V

Drive Voltage (Max Rds On, Min Rds On):

4.5V, 10V

Vgs(th) (Max) @ Id:

1V @ 250µA (Min)

Vgs (Max):

±20V

FET Feature:

-

Operating Temperature:

-55°C ~ 150°C (Tj)

Supplier Device Package:

PowerFlat™ (3.3x3.3)

Base Product Number:

STL9

Manufacturer:

STMicroelectronics

Product Status:

Active

Technology:

MOSFET (Metal Oxide)

Current - Continuous Drain (Id) @ 25°C:

9A (Tc)

Rds On (Max) @ Id, Vgs:

15mOhm @ 4.5A, 10V

Gate Charge (Qg) (Max) @ Vgs:

24 nC @ 4.5 V

Input Capacitance (Ciss) (Max) @ Vds:

2615 pF @ 25 V

Power Dissipation (Max):

3W (Ta)

Mounting Type:

Surface Mount

Package / Case:

8-PowerVDFN

## Environmental & Export classification

RoHS Status:

ROHS3 Compliant

REACH Status:

REACH Unaffected

HTSUS:

8541.29.0095

Moisture Sensitivity Level (MSL):

1 (Unlimited)

ECCN:

EAR99

## P-channel -30 V, 12 mΩ typ., -9 A STripFET™ H6 Power MOSFET in a PowerFLAT™ 3.3x3.3 package

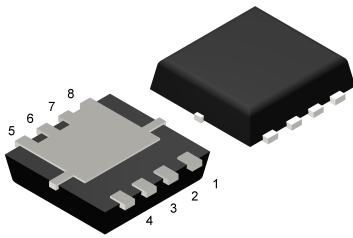

PowerFLAT™ 3.3x3.3

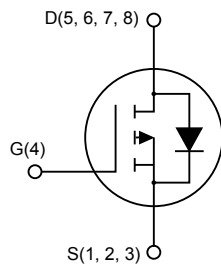

AM01475v4

### Features

Order code	$V_{DS}$	$R_{DS(on)}$ max	$I_D$
STL9P3LLH6	-30 V	15 mΩ	-9 A

- Very low on-resistance
- Very low gate charge
- High avalanche ruggedness
- Low gate drive power loss

### Applications

- Switching applications

### Description

This device is a P-channel Power MOSFET developed using the STripFET™ H6 technology with a new trench gate structure. The resulting Power MOSFET exhibits very low  $R_{DS(on)}$  in all packages.

#### Product status

STL9P3LLH6

#### Product summary

<b>Order code</b>	STL9P3LLH6
<b>Marking</b>	9P3L
<b>Package</b>	PowerFLAT™ 3.3x3.3
<b>Packing</b>	Tape and reel



## 1 Electrical ratings

**Table 1. Absolute maximum ratings**

Symbol	Parameter	Value	Unit
$V_{DS}$	Drain-source voltage	-30	V
$V_{GS}$	Gate-source voltage	$\pm 20$	V
$I_D$	Drain current (continuous) at $T_{pcb} = 25\text{ }^\circ\text{C}$	-9	A
$I_D$	Drain current (continuous) at $T_{pcb} = 100\text{ }^\circ\text{C}$	-5.9	A
$I_{DM}^{(1)}$	Drain current (pulsed)	-36	A
$P_{TOT}$	Total dissipation at $T_{pcb}=25\text{ }^\circ\text{C}$	3	W
$T_{stg}$	Storage temperature range	- 55 to 150	$^\circ\text{C}$
$T_j$	Operating junction temperature range		

1. Pulse width limited by safe operating area.

**Table 2. Thermal data**

Symbol	Parameter	Value	Unit
$R_{thj-case}$	Thermal resistance junction-case	2.5	$^\circ\text{C}/\text{W}$
$R_{thj-pcb}^{(1)}$	Thermal resistance junction-pcb	42	$^\circ\text{C}/\text{W}$

1. When mounted on FR-4 board of  $1\text{inch}^2$ , 2oz Cu  $t < 10\text{ s}$



## 2 Electrical characteristics

( $T_C = 25\text{ }^\circ\text{C}$  unless otherwise specified)

**Table 3. On /off states**

Symbol	Parameter	Test conditions	Min.	Typ.	Max.	Unit
$V_{(BR)DSS}$	Drain-source breakdown voltage	$V_{GS} = 0\text{ V}$ , $I_D = -1\text{ mA}$	-30			V
$I_{DSS}$	Zero gate voltage drain current	$V_{GS} = 0\text{ V}$ , $V_{DS} = -30\text{ V}$			-1	$\mu\text{A}$
		$V_{GS} = 0\text{ V}$ , $V_{DS} = -30\text{ V}$ , $T_C = 125\text{ }^\circ\text{C}$ <sup>(1)</sup>			-10	$\mu\text{A}$
$I_{GSS}$	Gate-body leakage current	$V_{DS} = 0\text{ V}$ , $V_{GS} = \pm 20\text{ V}$			$\pm 100$	nA
$V_{GS(th)}$	Gate threshold voltage	$V_{DS} = V_{GS}$ , $I_D = -250\text{ }\mu\text{A}$	-1			V
$R_{DS(on)}$	Static drain-source on-resistance	$V_{GS} = -10\text{ V}$ , $I_D = -4.5\text{ A}$		12	15	m $\Omega$
		$V_{GS} = -4.5\text{ V}$ , $I_D = -4.5\text{ A}$		18	22.5	m $\Omega$

1. Defined by design, not subject to production test.

**Table 4. Dynamic**

Symbol	Parameter	Test conditions	Min.	Typ.	Max.	Unit
$C_{iss}$	Input capacitance	$V_{DS} = -25\text{ V}$ , $f = 1\text{ MHz}$ , $V_{GS} = 0\text{ V}$	-	2615	-	pF
$C_{oss}$	Output capacitance		-	340	-	pF
$C_{riss}$	Reverse transfer capacitance		-	235	-	pF
$Q_g$	Total gate charge	$V_{DD} = -15\text{ V}$ , $I_D = -9\text{ A}$ ,	-	24	-	nC
$Q_{gs}$	Gate-source charge	$V_{GS} = -4.5\text{ to }0\text{ V}$ (see Figure 13. Gate charge test circuit)	-	9	-	nC
$Q_{gd}$	Gate-drain charge		-	8	-	nC

**Table 5. Switching times**

Symbol	Parameter	Test conditions	Min.	Typ.	Max.	Unit
$t_{d(on)}$	Turn-on delay time	$V_{DD} = -15\text{ V}$ , $I_D = -4.5\text{ A}$ , $R_G = 4.7\text{ }\Omega$ , $V_{GS} = -10\text{ V}$ (see Figure 12. Switching times test circuit for resistive load)	-	13.2	-	ns
$t_r$	Rise time		-	93	-	ns
$t_{d(off)}$	Turn-off delay time		-	50	-	ns
$t_f$	Fall time		-	18	-	ns

**Table 6. Source drain diode**

Symbol	Parameter	Test conditions	Min.	Typ.	Max.	Unit
$V_{SD}^{(1)}$	Forward on voltage	$I_{SD} = -9\text{ A}$ , $V_{GS} = 0\text{ V}$	-		-1.1	V



Symbol	Parameter	Test conditions	Min.	Typ.	Max.	Unit
$t_{rr}$	Reverse recovery time	$I_{SD} = -9\text{ A}$ , $di/dt = 100\text{ A}/\mu\text{s}$	-	20		ns
$Q_{rr}$	Reverse recovery charge	$V_{DD} = -24\text{ V}$ , $T_j = 150\text{ }^\circ\text{C}$	-	16		nC
$I_{RRM}$	Reverse recovery current	(see Figure 14. Test circuit for inductive load switching and diode recovery times)	-	-1.6		A

1. Pulsed: pulse duration = 300  $\mu\text{s}$ , duty cycle 1.5%

## 2.1 Electrical characteristics (curves)

Note: Note: For the P-channel Power MOSFET, current and voltage polarities are reversed.

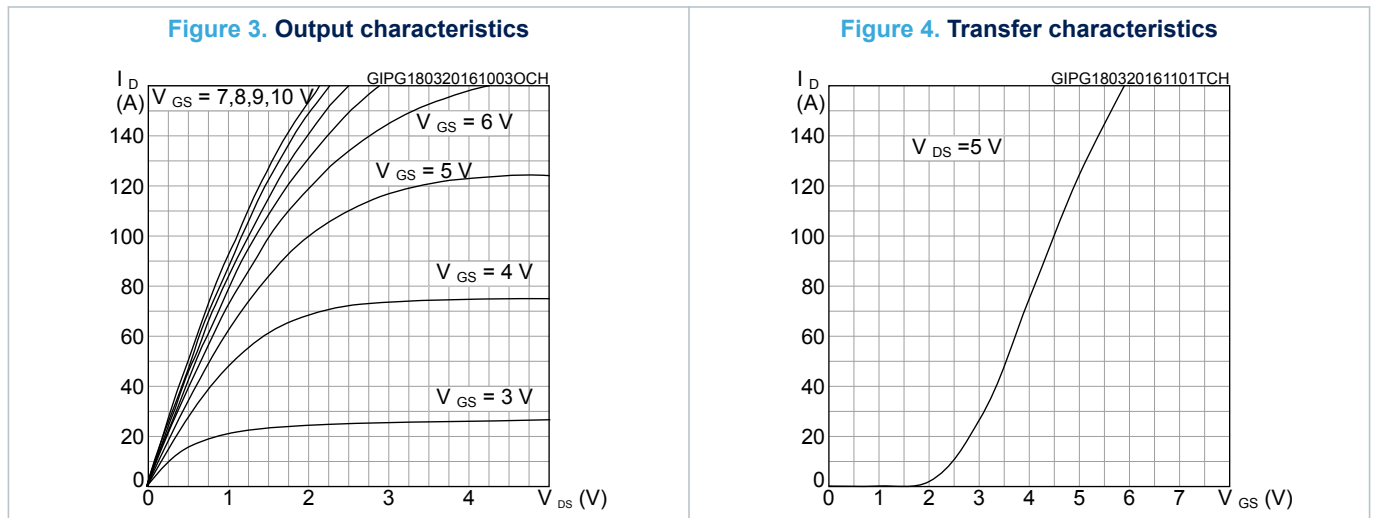
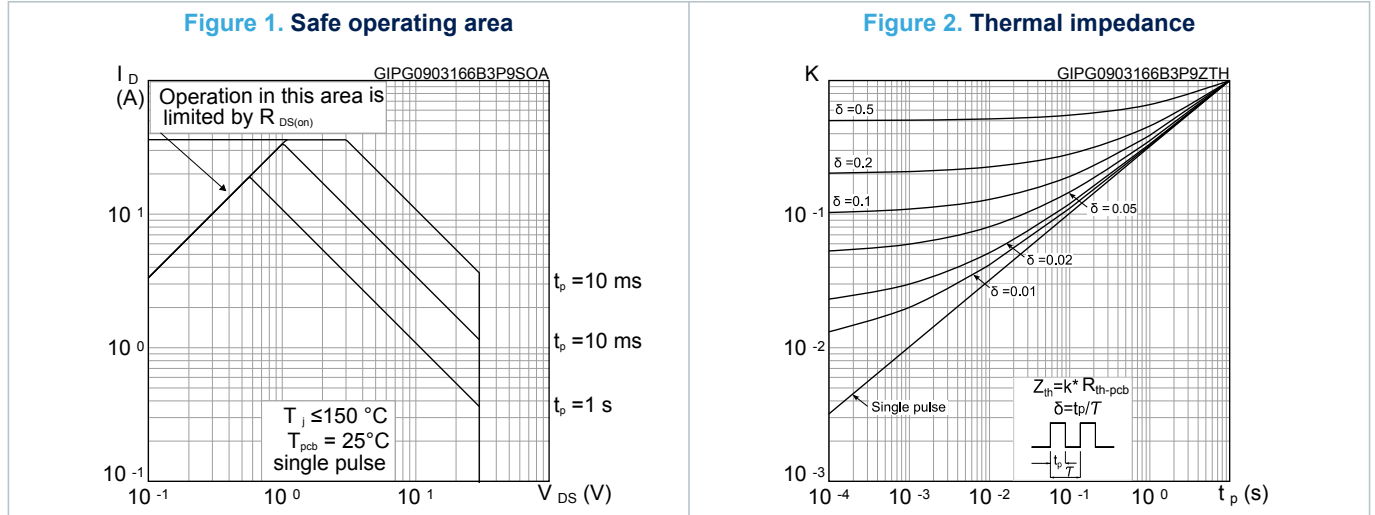

Figure 5. Gate charge vs gate-source voltage

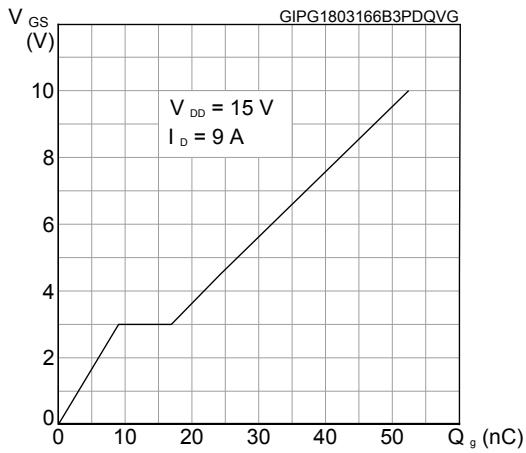

Figure 6. Static drain-source on-resistance

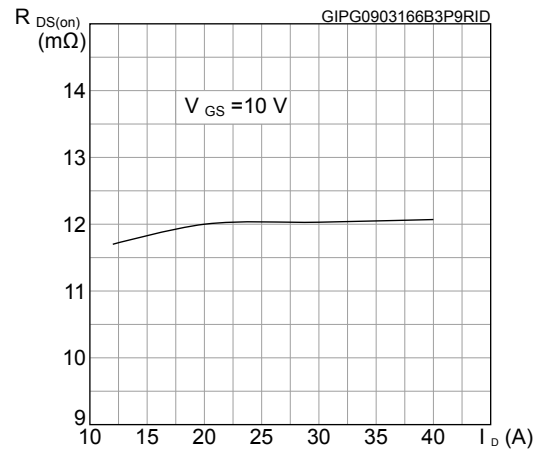

Figure 7. Capacitance variations

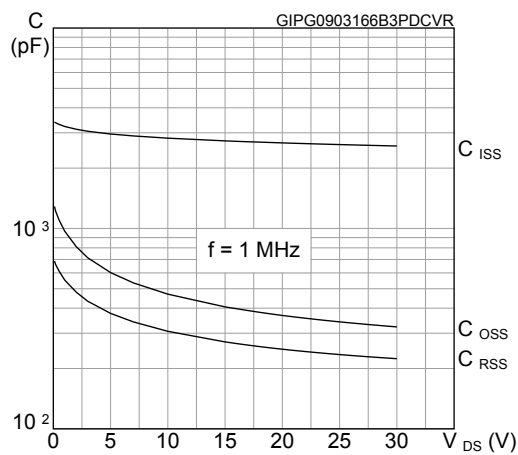

Figure 8. Normalized gate threshold voltage vs temperature

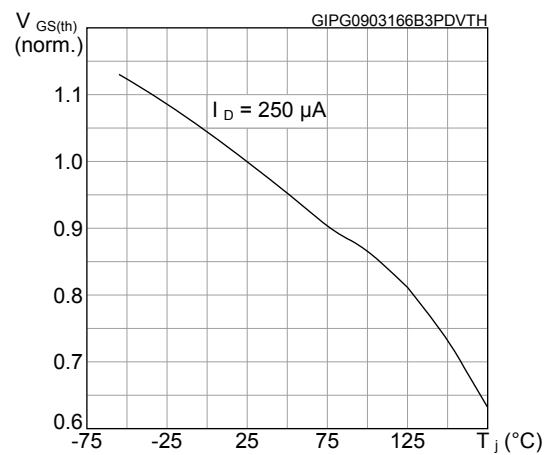

Figure 9. Normalized on-resistance vs temperature

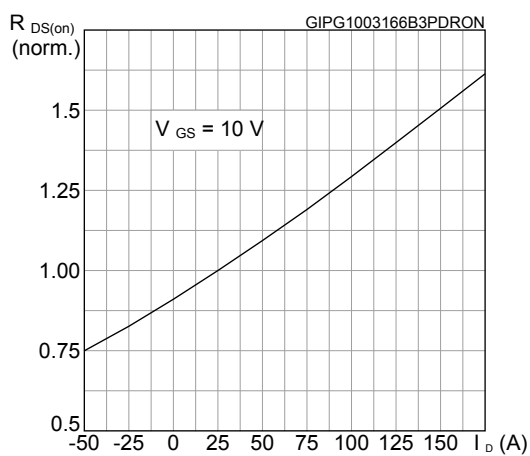

Figure 10. Normalized V\_(BR)DSS vs temperature

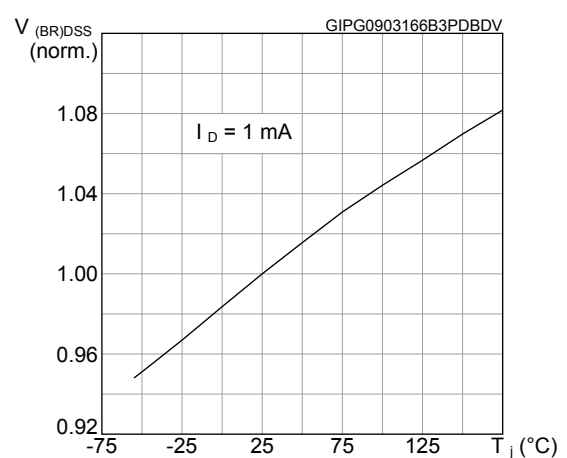
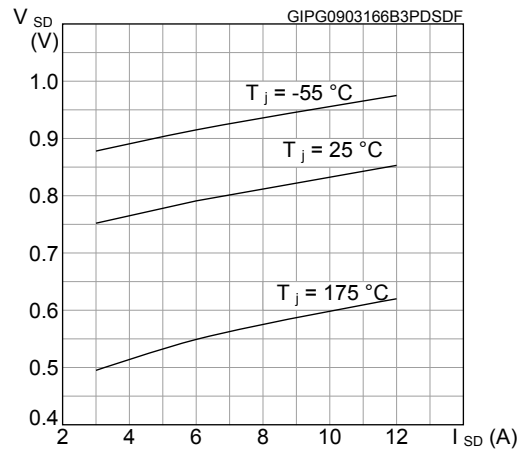

Figure 11. Source-drain diode forward characteristics



### 3 Test circuits

Figure 12. Switching times test circuit for resistive load

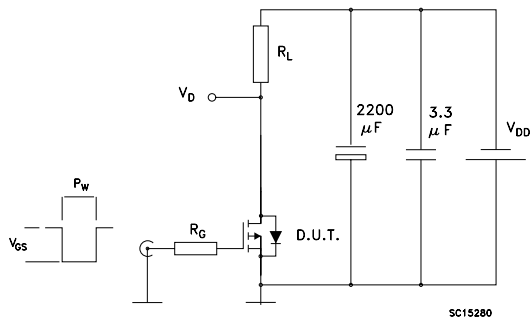

Figure 13. Gate charge test circuit

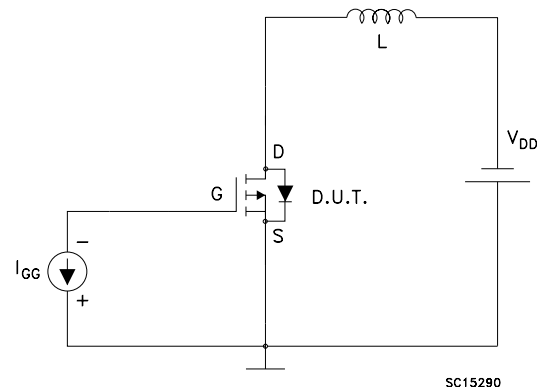
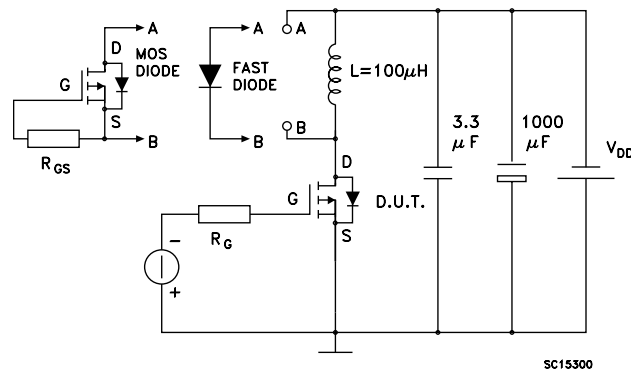

Figure 14. Test circuit for inductive load switching and diode recovery times





## 4 Package information

---

In order to meet environmental requirements, ST offers these devices in different grades of ECOPACK® packages, depending on their level of environmental compliance. ECOPACK® specifications, grade definitions and product status are available at: [www.st.com](http://www.st.com). ECOPACK® is an ST trademark.

#### 4.1 PowerFLAT™ 3.3x3.3 package information

Figure 15. PowerFLAT™ 3.3x3.3 package outline

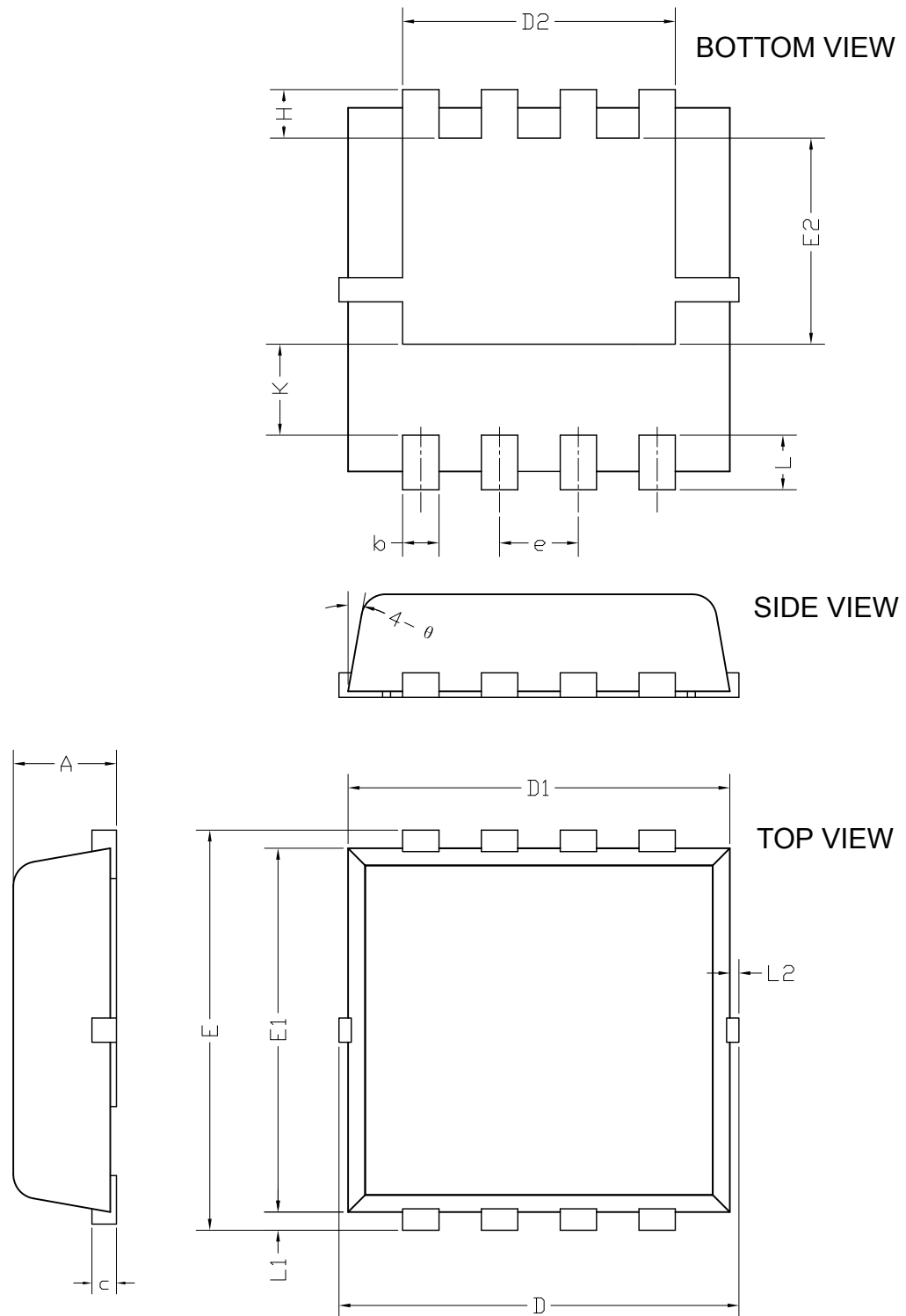

8465286\_2

**Table 7. PowerFLAT™ 3.3x3.3 package mechanical data**

Dim.	mm		
	Min.	Typ.	Max.
A	0.70	0.80	0.90
b	0.25	0.30	0.39
c	0.14	0.15	0.20
D	3.10	3.30	3.50
D1	3.05	3.15	3.25
D2	2.15	2.25	2.35
e	0.55	0.65	0.75
E	3.10	3.30	3.50
E1	2.90	3.00	3.10
E2	1.60	1.70	1.80
H	0.25	0.40	0.55
K	0.65	0.75	0.85
L	0.30	0.45	0.60
L1	0.05	0.15	0.25
L2			0.15
θ	8°	10°	12°

Figure 16. PowerFLAT™ 3.3x3.3 recommended footprint (dimensions are in mm)

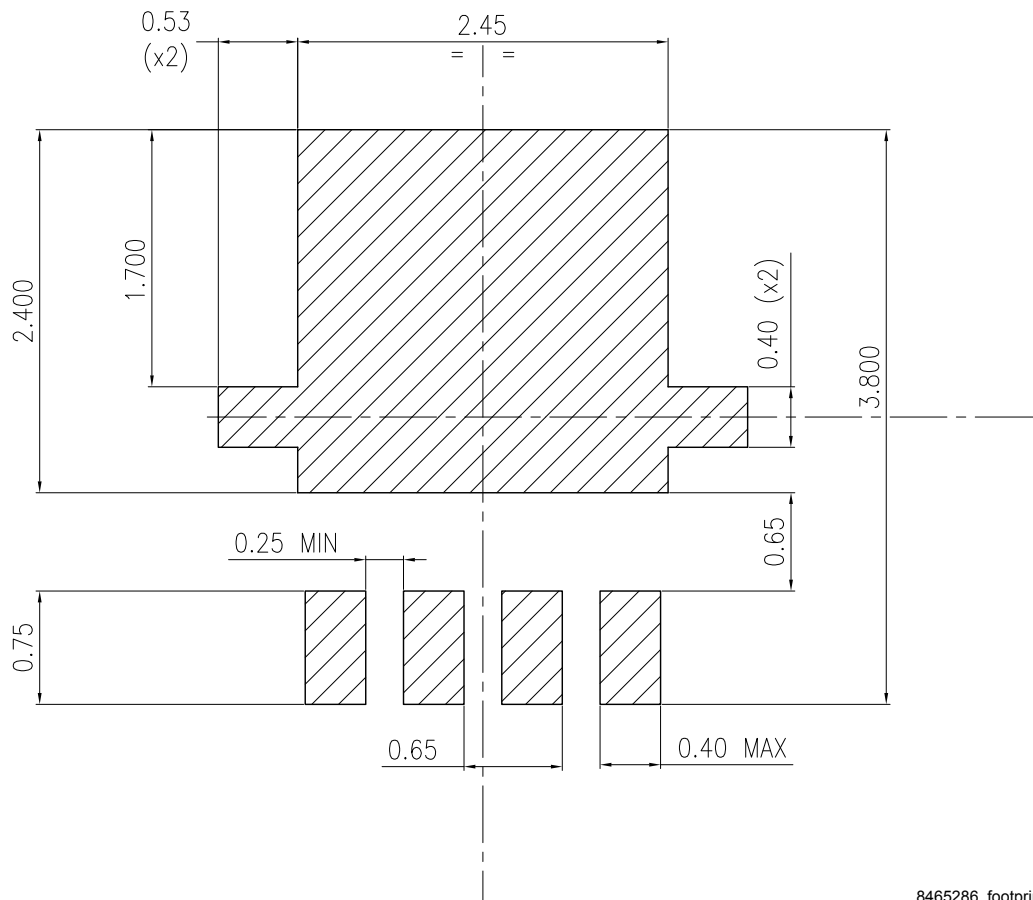

8465286\_footprint

## Revision history

**Table 8. Document revision history**

Date	Revision	Changes
23-Jan-2014	1	First release.
07-Mar-2016	2	Modified: title and $R_{DS(on)}$ max value Modified: <i>Table 2: "Absolute maximum ratings"</i> , <i>Table 4: "On /off states"</i> , <i>Table 5: "Dynamic"</i> , <i>Table 6: "Switching times"</i> and <i>Table 7: "Source drain diode"</i> Minor text changes.
20-Feb-2018	3	Updated <a href="#">Figure 1. Safe operating area</a> and <a href="#">Figure 2. Thermal impedance</a> . Removed maturity status indication from cover page. The document status is production data.



## Contents

<b>1</b>	<b>Electrical ratings</b> .....	<b>2</b>
<b>2</b>	<b>Electrical characteristics</b> .....	<b>3</b>
<b>2.1</b>	<b>Electrical characteristics (curves)</b> .....	<b>5</b>
<b>3</b>	<b>Test circuits</b> .....	<b>8</b>
<b>4</b>	<b>Package information</b> .....	<b>9</b>
<b>4.1</b>	<b>PowerFLAT™ 3.3x3.3 package information</b> .....	<b>9</b>
	<b>Revision history</b> .....	<b>13</b>
	<b>Contents</b> .....	<b>14</b>
	<b>Disclaimer</b> .....	<b>15</b>

**IMPORTANT NOTICE – PLEASE READ CAREFULLY**

STMicroelectronics NV and its subsidiaries (“ST”) reserve the right to make changes, corrections, enhancements, modifications, and improvements to ST products and/or to this document at any time without notice. Purchasers should obtain the latest relevant information on ST products before placing orders. ST products are sold pursuant to ST’s terms and conditions of sale in place at the time of order acknowledgement.

Purchasers are solely responsible for the choice, selection, and use of ST products and ST assumes no liability for application assistance or the design of Purchasers’ products.

No license, express or implied, to any intellectual property right is granted by ST herein.

Resale of ST products with provisions different from the information set forth herein shall void any warranty granted by ST for such product.

ST and the ST logo are trademarks of ST. All other product or service names are the property of their respective owners.

Information in this document supersedes and replaces information previously supplied in any prior versions of this document.

© 2018 STMicroelectronics – All rights reserved

## OUR CERTIFICATE

DiGi provide top-quality products and perfect service for customer worldwide through standardization, technological innovation and continuous improvement. DiGi through third-party certification, we stricly control the quality of products and services. Welcome your RFQ to

Email: [Info@DiGi-Electronics.com](mailto:Info@DiGi-Electronics.com)



Tel: +00 852-30501935

RFQ Email: [Info@DiGi-Electronics.com](mailto:Info@DiGi-Electronics.com)

DiGi is a global authorized distributor of electronic components.