

STM708TM6F Datasheet

www.digi-electronics.com

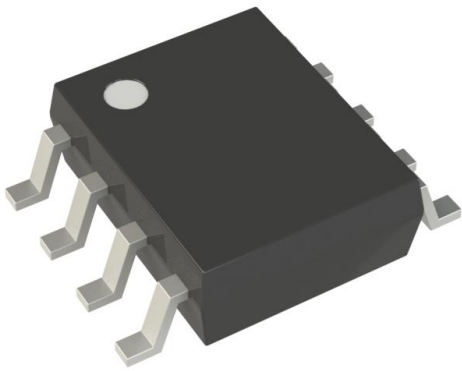

<https://www.DiGi-Electronics.com>

DiGi Electronics Part Number	STM708TM6F-DG
Manufacturer	STMicroelectronics
Manufacturer Product Number	STM708TM6F
Description	IC SUPERVISOR 1 CHANNEL 8SO
Detailed Description	Supervisor Push-Pull, Totem Pole 1 Channel 8-SOIC

This model STM708TM6F is available at DiGi Electronics.

DiGi Electronics offers a global database of semiconductor and electronic component datasheets.

We welcome your inquiries regarding pricing, lead time, or other product-related questions.

 [Request a Quote](#)

 [Datasheet Search](#)



Tel: +00 852-30501935

RFQ Email: Info@DiGi-Electronics.com

DiGi is a global authorized distributor of electronic components.

Purchase and inquiry

Manufacturer Product Number:

STM708TM6F

Series:

-

DiGi-Electronics Programmable:

Not Verified

Number of Voltages Monitored:

1

Output:

Push-Pull, Totem Pole

Reset Timeout:

140ms Minimum

Mounting Type:

Surface Mount

Supplier Device Package:

8-SOIC

Manufacturer:

STMicroelectronics

Product Status:

Active

Type:

Simple Reset/Power-On Reset

Voltage - Threshold:

3.08V

Reset:

Active High/Active Low

Operating Temperature:

-40°C ~ 85°C (TA)

Package / Case:

8-SOIC (0.154", 3.90mm Width)

Base Product Number:

STM708

Environmental & Export classification

RoHS Status:

ROHS3 Compliant

REACH Status:

REACH Unaffected

HTSUS:

8542.39.0001

Moisture Sensitivity Level (MSL):

1 (Unlimited)

ECCN:

EAR99



STM706T/S/R, STM706P, STM708T/S/R

3 V supervisor

Datasheet - production data

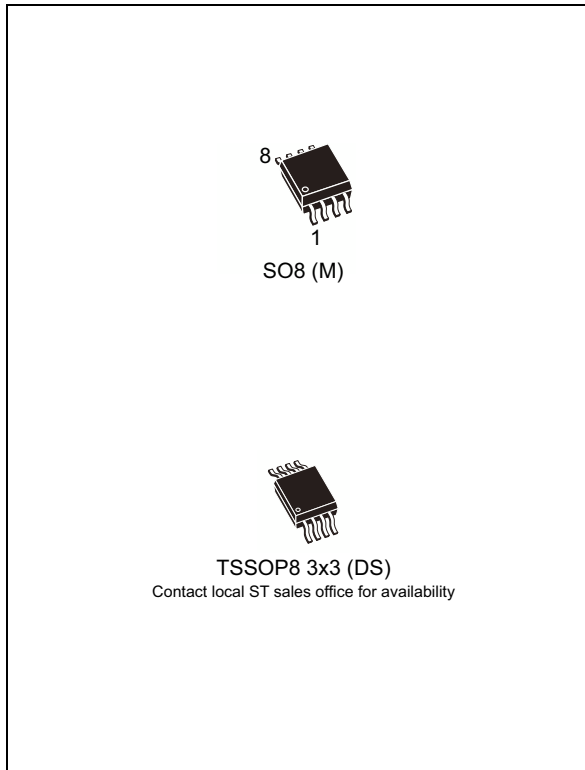

- RST and $\overline{\text{RST}}$ outputs
- 200 ms (typ.) t_{rec}
- Watchdog timer - 1.6 s (typ.)
- Manual reset input ($\overline{\text{MR}}$)
- Power-fail comparator (PFI/ $\overline{\text{PFO}}$)
- Low supply current - 40 μA (typ.)
- Guaranteed $\overline{\text{RST}}$ (RST) assertion down to $V_{\text{CC}} = 1.0 \text{ V}$
- Operating temperature: $-40 \text{ }^\circ\text{C}$ to $85 \text{ }^\circ\text{C}$ (industrial grade)
- RoHS compliance
 - Lead-free components are compliant with the RoHS directive

Application

- Computers
- Controllers
- Intelligent instruments

Features

- Precision V_{CC} monitor
 - T: $3.00 \text{ V} \leq V_{\text{RST}} \leq 3.15 \text{ V}$
 - S: $2.88 \text{ V} \leq V_{\text{RST}} \leq 3.00 \text{ V}$
 - R: STM706P: $2.59 \text{ V} \leq V_{\text{RST}} \leq 2.70 \text{ V}$

Table 1. Device summary

	Watchdog input	Watchdog output ⁽¹⁾	Active-low $\overline{\text{RST}}$ ⁽¹⁾	Active-high RST ⁽¹⁾	Manual reset input	Power-fail comparator
STM706T/S/R	√	√	√		√	√
STM706P ⁽²⁾	√	√		√	√	√
STM708T/S/R			√	√	√	√

1. Push-pull output

2. The STM706P device is identical to the STM706R device, except its reset output is active high.

Contents

1	Description	6
2	Pin descriptions	9
2.1	$\overline{\text{MR}}$	9
2.2	WDI	9
2.3	$\overline{\text{WDO}}$	9
2.4	$\overline{\text{RST}}$	9
2.5	RST	9
2.6	PFI	9
2.7	$\overline{\text{PFO}}$	10
3	Operation	12
3.1	Reset output	12
3.2	Push-button reset input	12
3.3	Watchdog input (STM706T/S/R and STM706P)	12
3.4	Watchdog output (STM706T/S/R and STM706P)	12
3.5	Power-fail input/output	13
3.6	Ensuring a valid reset output down to $V_{\text{CC}} = 0 \text{ V}$	13
3.7	Interfacing to microprocessors with bi-directional reset pins	14
4	Typical operating characteristics	15
5	Maximum ratings	22
6	DC and AC parameters	23
7	Package information	27
7.1	SO8 package information	28
7.2	TSSOP8 3x3 (DS) package information	29
8	Part numbering	30
9	Revision history	32

List of tables

Table 1.	Device summary	1
Table 2.	Signal names	6
Table 3.	Pin description	9
Table 4.	Absolute maximum ratings	21
Table 5.	Operating and AC measurement conditions.	22
Table 6.	DC and AC characteristics	24
Table 7.	SO8 - 8-lead plastic small outline, 150 mils body width, mechanical data	27
Table 8.	TSSOP8 - 8-lead, thin shrink small outline, 3 x 3 mm body size, mechanical data	28
Table 9.	Ordering information scheme	29
Table 10.	Marking description.	30
Table 11.	Document revision history	31

List of figures

Figure 1.	Logic diagram (STM706T/S/R and STM706P)	5
Figure 2.	Logic diagram (STM708T/S/R)	5
Figure 3.	STM706T/S/R and STM706P SO8 connections.	6
Figure 4.	STM706T/S/R and STM706P TSSOP8 connections	6
Figure 5.	STM708T/S/R SO8 connections	6
Figure 6.	STM708T/S/R TSSOP8 connections	7
Figure 7.	Block diagram (STM706T/S/R and STM706P).	9
Figure 8.	Block diagram (STM708T/S/R).	10
Figure 9.	Hardware hookup	10
Figure 10.	Reset output valid to ground circuit	12
Figure 11.	Interfacing to microprocessors with bi-directional reset I/O	13
Figure 12.	Supply current vs. temperature (no load)	14
Figure 13.	V_{PFI} threshold vs. temperature	14
Figure 14.	Reset comparator propagation delay vs. temperature	15
Figure 15.	Power-up t_{rec} vs. temperature	15
Figure 16.	Normalized reset threshold vs. temperature	16
Figure 17.	Watchdog timeout period vs. temperature	16
Figure 18.	PFI to \overline{PFO} propagation delay vs. temperature	17
Figure 19.	Output voltage vs. load current ($V_{CC} = 5\text{ V}$; $T_A = 25\text{ }^\circ\text{C}$)	17
Figure 20.	\overline{RST} output voltage vs. supply voltage	18
Figure 21.	RST output voltage vs. supply voltage	18
Figure 22.	Power-fail comparator response time (assertion)	19
Figure 23.	Power-fail comparator response time (de-assertion)	19
Figure 24.	Maximum transient duration vs. reset threshold overdrive	20
Figure 25.	AC testing input/output waveforms	22
Figure 26.	Power-fail comparator waveform	22
Figure 27.	\overline{MR} timing waveform	23
Figure 28.	Watchdog timing (STM706T/S/R and STM706P)	23
Figure 29.	SO8 - 8-lead plastic small outline, 150 mils body width, package outline.	27
Figure 30.	TSSOP8 - 8-lead, thin shrink small outline, 3 x 3 mm body size, package outline.	28

1 Description

The STM70x supervisors are self-contained devices which provide microprocessor supervisory functions. A precision voltage reference and comparator monitors the V_{CC} input for an out-of-tolerance condition. When an invalid V_{CC} condition occurs, the reset output (\overline{RST}) is forced low (or high in the case of RST).

These devices also offer a watchdog timer (except for STM708T/S/R) as well as a power-fail comparator to provide the system with an early warning of impending power failure.

The STM706P device is identical to the STM706R device, except its reset output is active high. These devices are available in a standard 8-pin SOIC package or a space-saving 8-pin TSSOP package.

Figure 1. Logic diagram (STM706T/S/R and STM706P)

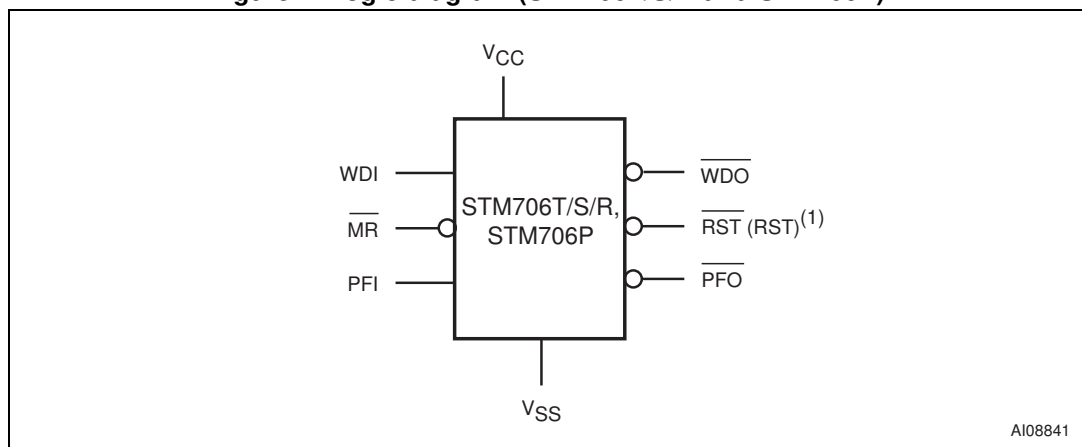

1. For STM706P only.

Figure 2. Logic diagram (STM708T/S/R)

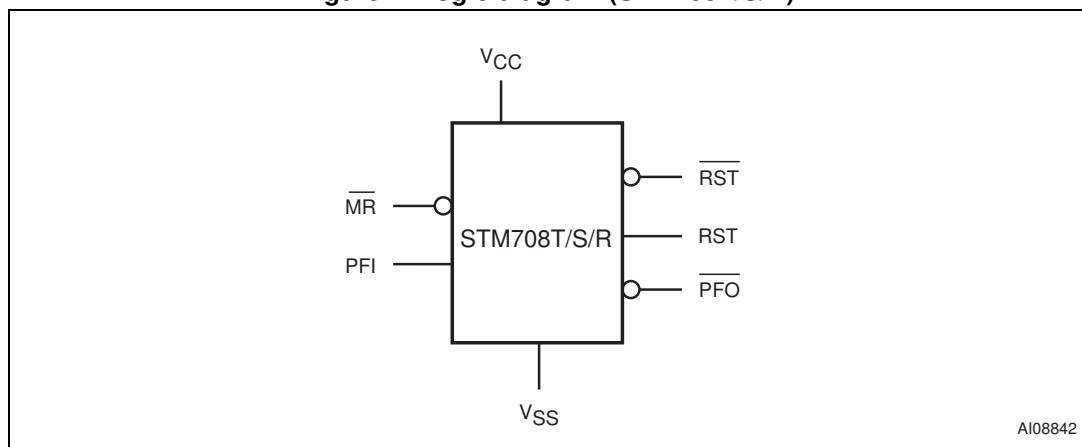
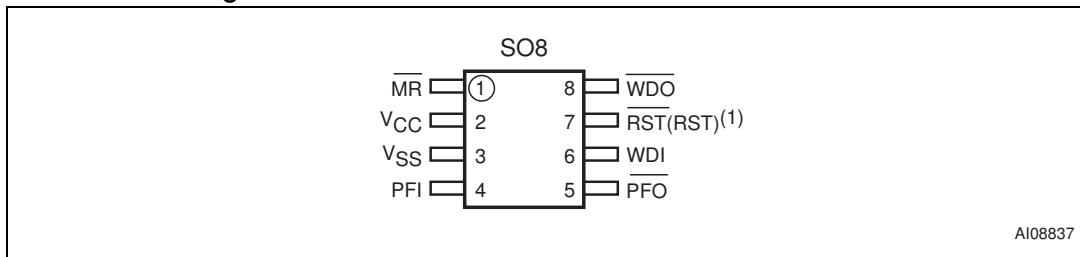

Table 2. Signal names

Symbol	Name
MR	Push-button reset input
WDI	Watchdog input
WDO	Watchdog output
RST	Active low reset output
RST ⁽¹⁾	Active high reset output
V _{CC}	Supply voltage
PFI	Power-fail input
PFO	Power-fail output
V _{SS}	Ground
NC	No connect

1. For STM706P and STM708T/S/R only.

Figure 3. STM706T/S/R and STM706P SO8 connections



1. For STM706P reset output is active high.

Figure 4. STM706T/S/R and STM706P TSSOP8 connections

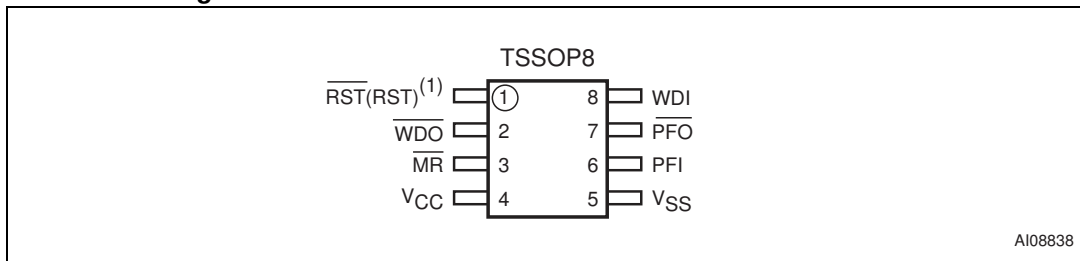

1. For STM706P reset output is active high.

Figure 5. STM708T/S/R SO8 connections

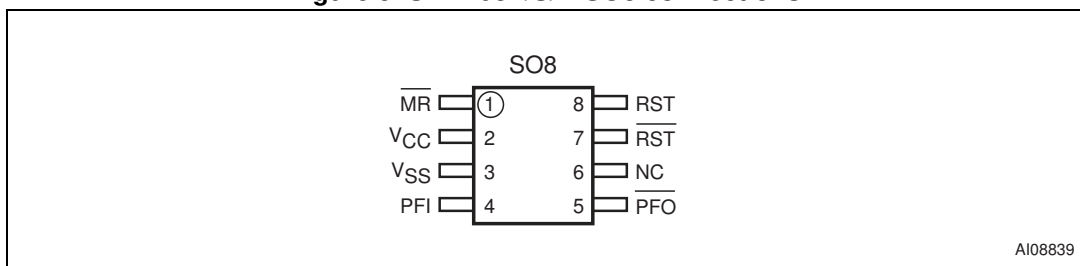
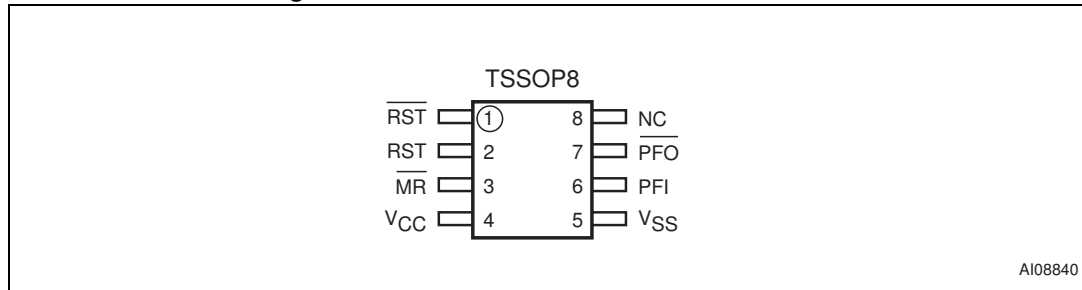

Figure 6. STM708T/S/R TSSOP8 connections



2 Pin descriptions

2.1 $\overline{\text{MR}}$

A logic low on $\overline{\text{MR}}$ asserts the reset output. Reset remains asserted as long as $\overline{\text{MR}}$ is low and for t_{rec} after $\overline{\text{MR}}$ returns high. This active low input has an internal pull-up. It can be driven from a TTL or CMOS logic line, or shorted to ground with a switch. Leave open if unused.

2.2 WDI

If WDI remains high or low for 1.6 s, the internal watchdog timer runs out and reset (or $\overline{\text{WDO}}$) is triggered. The internal watchdog timer clears while reset is asserted or when WDI sees a rising or falling edge.

The watchdog function can be disabled by allowing the WDI pin to float. This feature is available for the “D” version only (see [Section 8: Part numbering](#)).

2.3 $\overline{\text{WDO}}$

$\overline{\text{WDO}}$ goes low when a transition does not occur on WDI within 1.6 s, and remains low until a transition occurs on WDI (indicating the watchdog interrupt has been serviced) or $\overline{\text{MR}}$ input is asserted (goes low). $\overline{\text{WDO}}$ also goes low when V_{CC} falls below the reset threshold; however, unlike the reset output, $\overline{\text{WDO}}$ goes high as soon as V_{CC} exceeds the reset threshold. Output type is push-pull.

Note: For those devices with a $\overline{\text{WDO}}$ output, a watchdog timeout will not trigger reset unless $\overline{\text{WDO}}$ is connected to $\overline{\text{MR}}$.

2.4 $\overline{\text{RST}}$

Pulses low for t_{rec} when triggered, and stays low whenever V_{CC} is below the reset threshold or when $\overline{\text{MR}}$ is a logic low. It remains low for t_{rec} after either V_{CC} rises above the reset threshold, the watchdog triggers a reset, or $\overline{\text{MR}}$ goes from low to high.

2.5 RST

Pulses high for t_{rec} when triggered, and stays high whenever V_{CC} is above the reset threshold or when $\overline{\text{MR}}$ is a logic high. It remains high for t_{rec} after either V_{CC} falls below the reset threshold, the watchdog triggers a reset, or $\overline{\text{MR}}$ goes from high to low.

2.6 PFI

When PFI is less than V_{PFI} , $\overline{\text{PFO}}$ goes low; otherwise, $\overline{\text{PFO}}$ remains high. Connect to ground if unused.

2.7 $\overline{\text{PFO}}$

When PFI is less than V_{PFI} , $\overline{\text{PFO}}$ goes low; otherwise, $\overline{\text{PFO}}$ remains high. Output type is push-pull. $\overline{\text{PFO}}$ pin is not supposed to be forced low by a processor. MR input is gated off during the period $\overline{\text{PFO}}$ is forced low. Leave open if unused.

Table 3. Pin description

Pin						Name	Function
STM706P		STM706T/S/R		STM708T/S/R			
SO8	TSSOP8	SO8	TSSOP8	SO8	TSSOP8		
1	3	1	3	1	3	$\overline{\text{MR}}$	Push-button reset input
6	8	6	8	—	—	WDI	Watchdog input
8	2	8	2	—	—	$\overline{\text{WDO}}$	Watchdog output (push-pull)
—	—	7	1	7	1	RST	Active low reset output
7	1	—	—	8	2	RST	Active high reset output
2	4	2	4	2	4	V_{CC}	Supply voltage
4	6	4	6	4	6	PFI	Power-fail input
5	7	5	7	5	7	$\overline{\text{PFO}}$	Power-fail output (push-pull)
3	5	3	5	3	5	V_{SS}	Ground
—	—	—	—	6	8	NC	No connect

Figure 7. Block diagram (STM706T/S/R and STM706P)

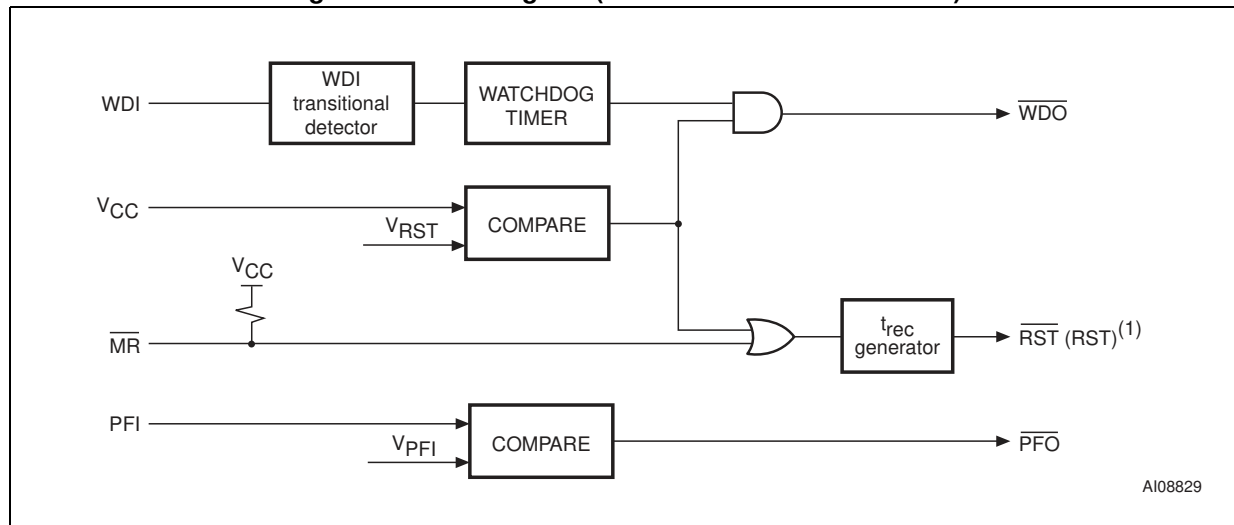

1. For STM706P only

Figure 8. Block diagram (STM708T/S/R)

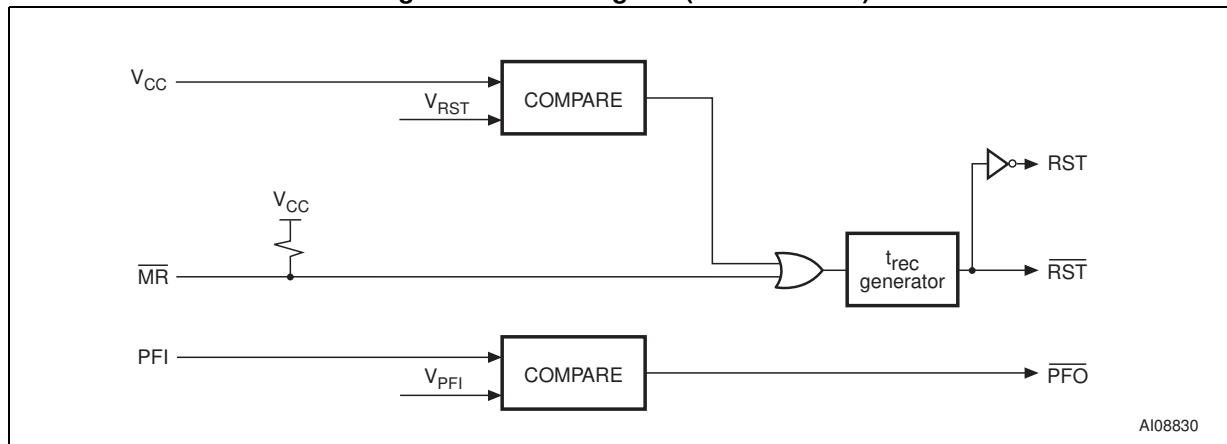
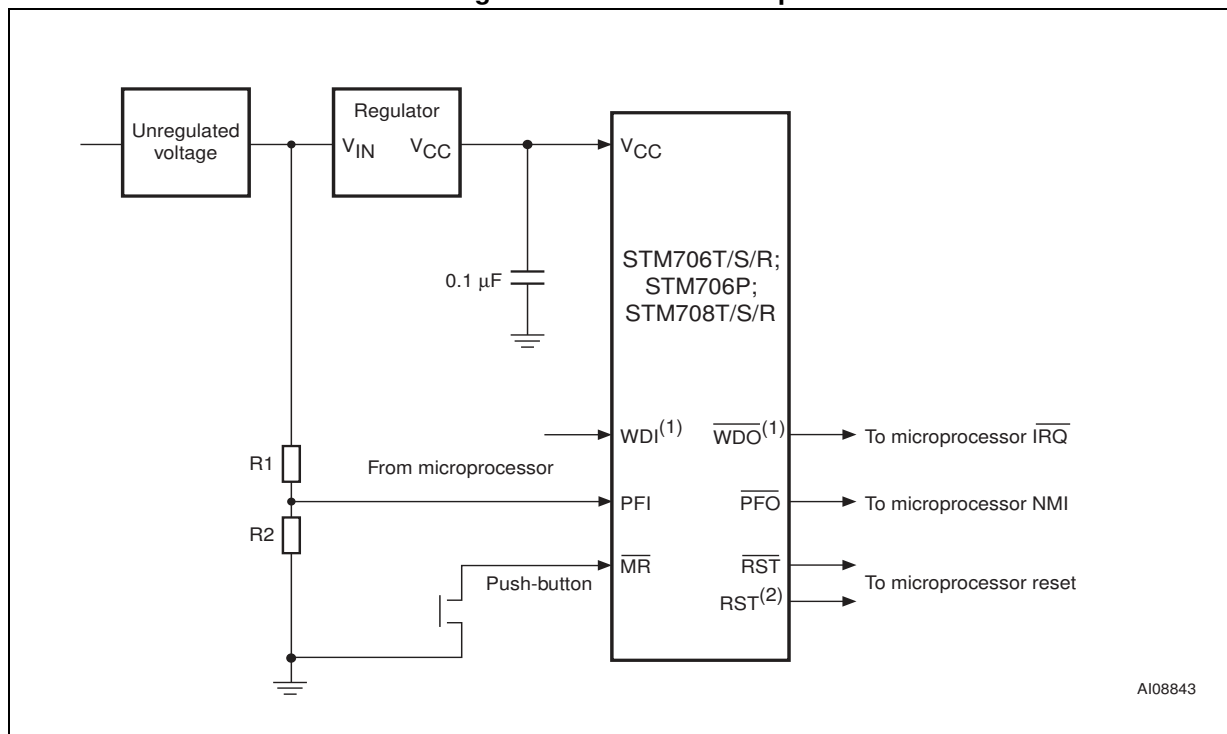

Figure 9. Hardware hookup



1. For STM706T/S/R and STM706P devices
2. For STM706P and STM708T/S/R devices

3 Operation

3.1 Reset output

The STM70x supervisor asserts a reset signal to the MCU whenever V_{CC} goes below the reset threshold (V_{RST}), a watchdog timeout occurs (if \overline{WDO} is connected to \overline{MR}), or when the push-button reset input (\overline{MR}) is taken low. \overline{RST} is guaranteed to be a logic low (logic high for STM706P and STM708T/S/R) for $V_{CC} < V_{RST}$ down to $V_{CC} = 1$ V for $T_A = 0$ °C to 85 °C.

During power-up, once V_{CC} exceeds the reset threshold an internal timer keeps \overline{RST} low for the reset timeout period, t_{rec} . After this interval \overline{RST} returns high.

If V_{CC} drops below the reset threshold, \overline{RST} goes low. Each time \overline{RST} is asserted, it stays low for at least the reset timeout period (t_{rec}). Any time V_{CC} goes below the reset threshold the internal timer clears. The reset timer starts when V_{CC} returns above the reset threshold.

3.2 Push-button reset input

A logic low on \overline{MR} asserts reset. Reset remains asserted while \overline{MR} is low, and for t_{rec} (see [Figure 27](#)) after it returns high. The \overline{MR} input has an internal 40 k Ω pull-up resistor, allowing it to be left open if not used. This input can be driven with TTL/CMOS-logic levels or with open-drain / collector outputs. Connect a normally open momentary switch from \overline{MR} to GND to create a manual reset function; external debounce circuitry is not required. If \overline{MR} is driven from long cables or the device is used in a noisy environment, connect a 0.1 μ F capacitor from \overline{MR} to GND to provide additional noise immunity. \overline{MR} may float, or be tied to V_{CC} when not used.

3.3 Watchdog input (STM706T/S/R and STM706P)

The watchdog timer can be used to detect an out-of-control MCU. If the MCU does not toggle the watchdog input (WDI) within t_{WD} (1.6 s), the watchdog output pin (\overline{WDO}) is asserted. The internal 1.6s timer is cleared by either:

1. a reset pulse, or
2. by toggling WDI (high-to-low or low-to-high), which can detect pulses as short as 50 ns.

See [Figure 28](#) for STM706T/S/R and STM706P.

The timer remains cleared and does not count for as long as reset is asserted. As soon as reset is released, the timer starts counting.

Note: The watchdog function may be disabled by floating WDI or tri-stating the driver connected to WDI. When tri-stated or disconnected, the maximum allowable leakage current is 10 μ A and the maximum allowable load capacitance is 200 pF.

3.4 Watchdog output (STM706T/S/R and STM706P)

When V_{CC} drops below the reset threshold, \overline{WDO} will go low even if the watchdog timer has not yet timed out. However, unlike the reset output, \overline{WDO} goes high as soon as V_{CC}

exceeds the reset threshold. \overline{WDO} may be used to generate a reset pulse by connecting it to the \overline{MR} input.

3.5 Power-fail input/output

The power-fail input (PFI) is compared to an internal reference voltage (independent from the V_{RST} comparator). If PFI is less than the power-fail threshold (V_{PFI}), the power-fail output (PFO) will go low. This function is intended for use as an undervoltage detector to signal a failing power supply. Typically PFI is connected through an external voltage divider (see [Figure 9](#)) to either the unregulated DC input (if it is available) or the regulated output of the V_{CC} regulator. The voltage divider can be set up such that the voltage at PFI falls below V_{PFI} several milliseconds before the regulated V_{CC} input to the STM70x or the micro-processor drops below the minimum operating voltage.

If the comparator is unused, PFI should be connected to V_{SS} and \overline{PFO} left unconnected. \overline{PFO} may be connected to \overline{MR} on the STM70x so that a low voltage on PFI will generate a reset output.

3.6 Ensuring a valid reset output down to $V_{CC} = 0$ V

When V_{CC} falls below 1 V, the state of the \overline{RST} output can no longer be guaranteed, and becomes essentially an open circuit. If a high value pulldown resistor is added to the \overline{RST} pin, the output will be held low during this condition. A resistor value of approximately 100 k Ω will be large enough to not load the output under operating conditions, but still sufficient to pull \overline{RST} to ground during this low voltage condition (see [Figure 10](#)).

Figure 10. Reset output valid to ground circuit

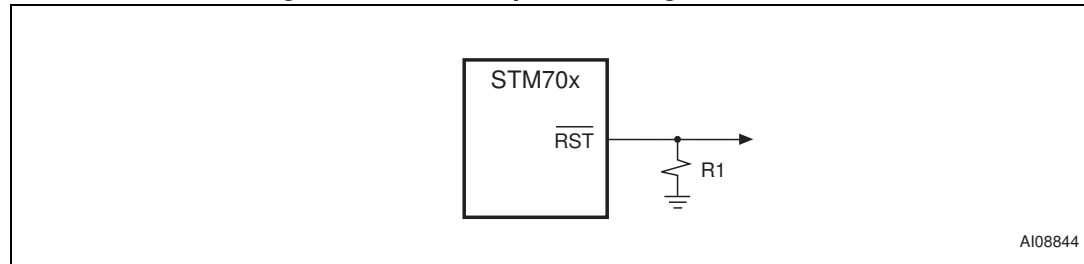

AI08844

3.7 Interfacing to microprocessors with bi-directional reset pins

Microprocessors with bi-directional reset pins can contend with the STM70x reset output. For example, if the reset output is driven high and the micro wants to pull it low, signal contention will result. To prevent this from occurring, connect a 4.7k Ω resistor between the reset output and the micro's reset I/O as in [Figure 11](#).

Figure 11. Interfacing to microprocessors with bi-directional reset I/O

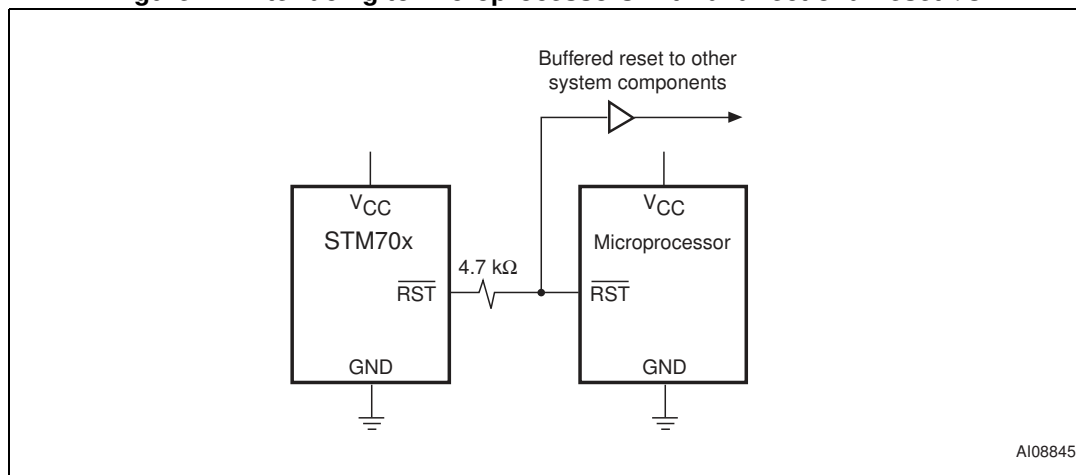

4 Typical operating characteristics

Typical values are at $T_A = 25\text{ }^\circ\text{C}$.

Figure 12. Supply current vs. temperature (no load)

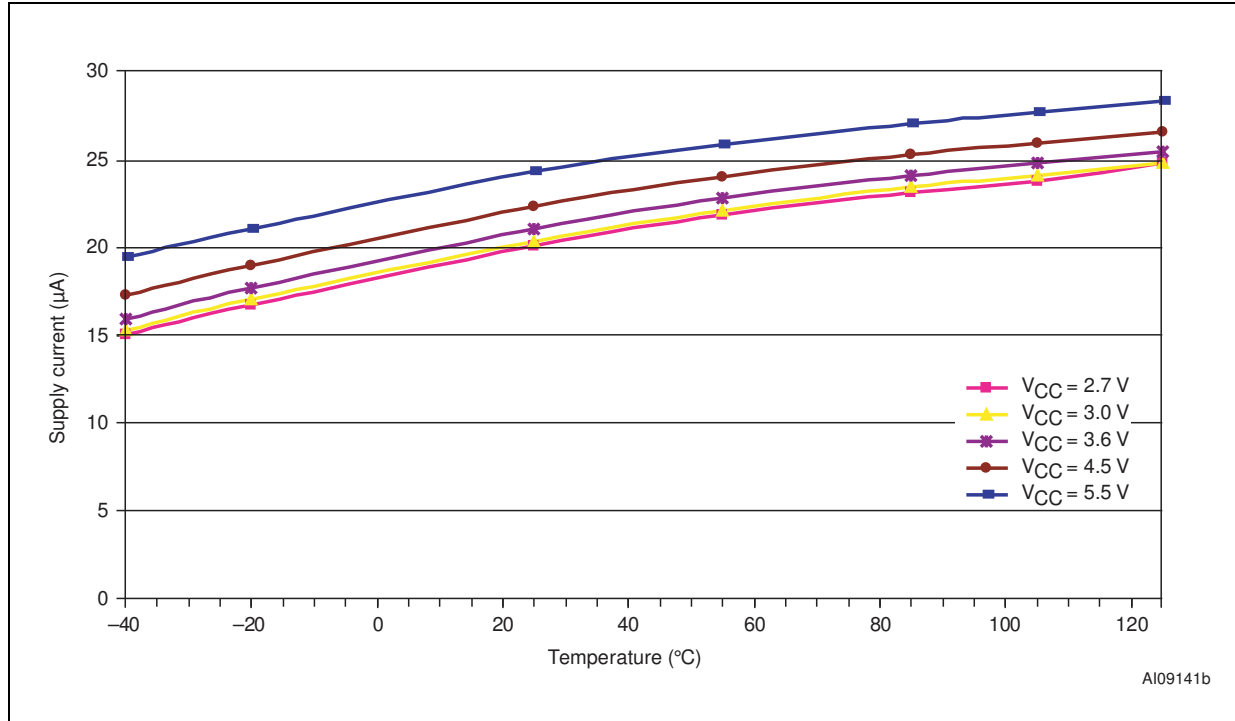

Figure 13. V_{PFI} threshold vs. temperature

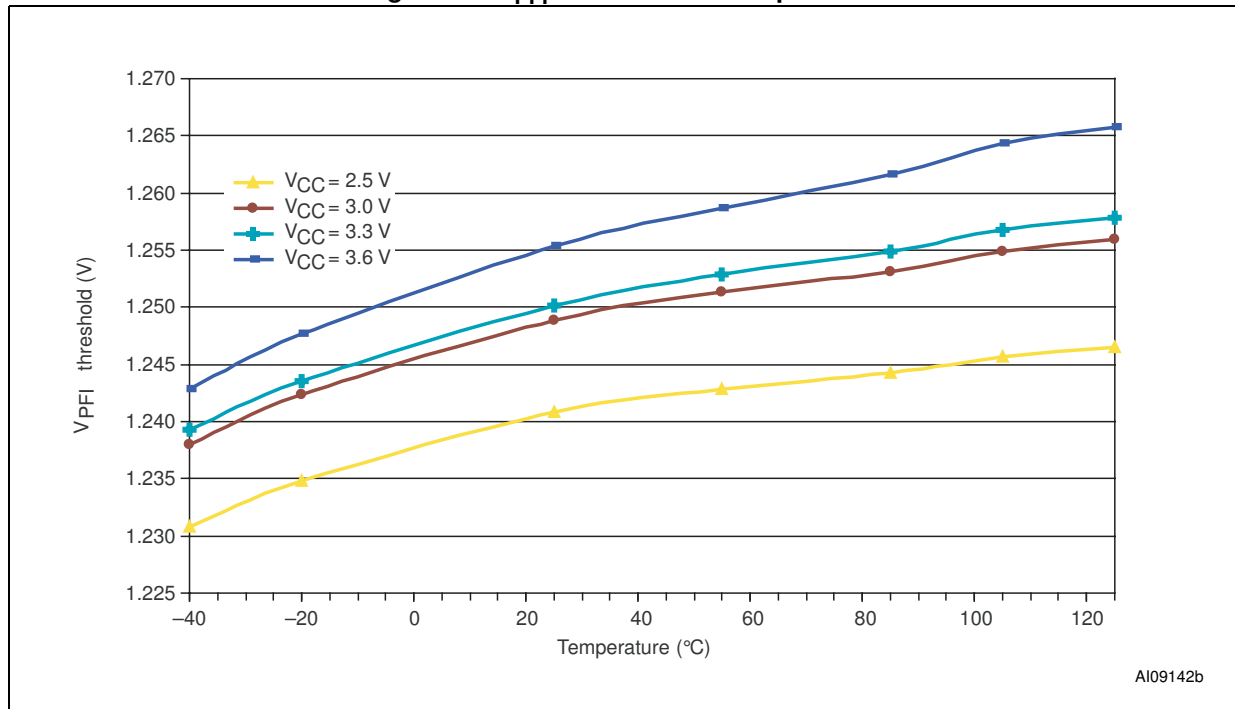

Figure 14. Reset comparator propagation delay vs. temperature

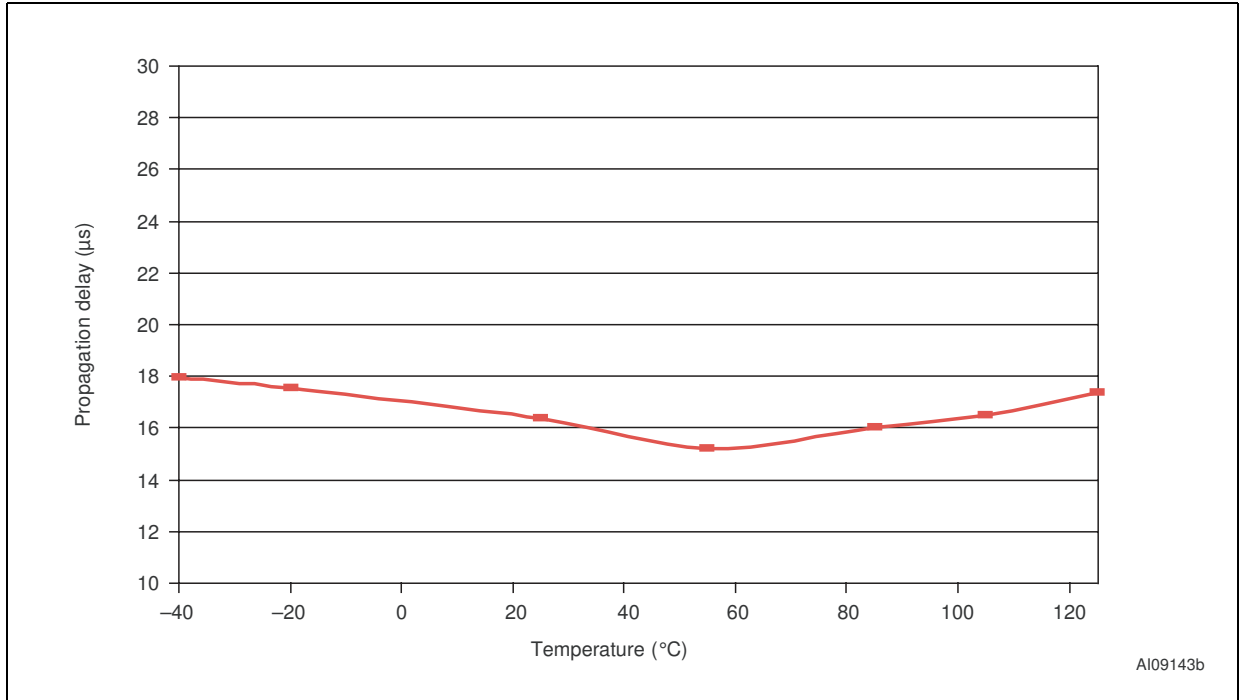

Figure 15. Power-up t_{rec} vs. temperature

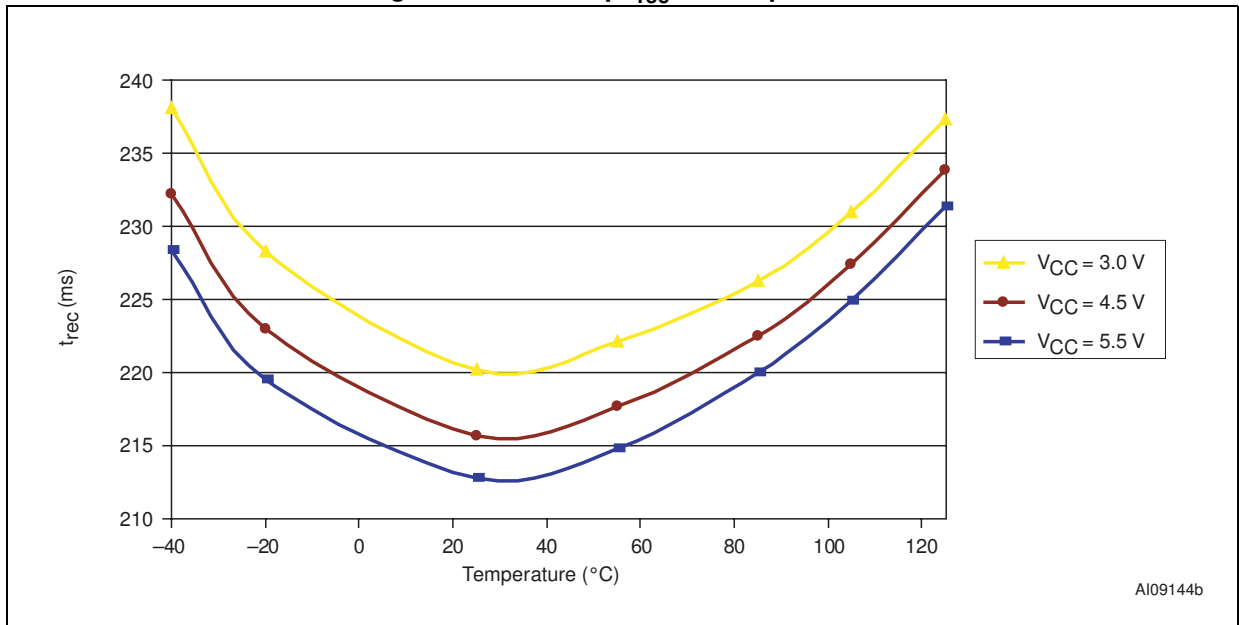

Figure 16. Normalized reset threshold vs. temperature

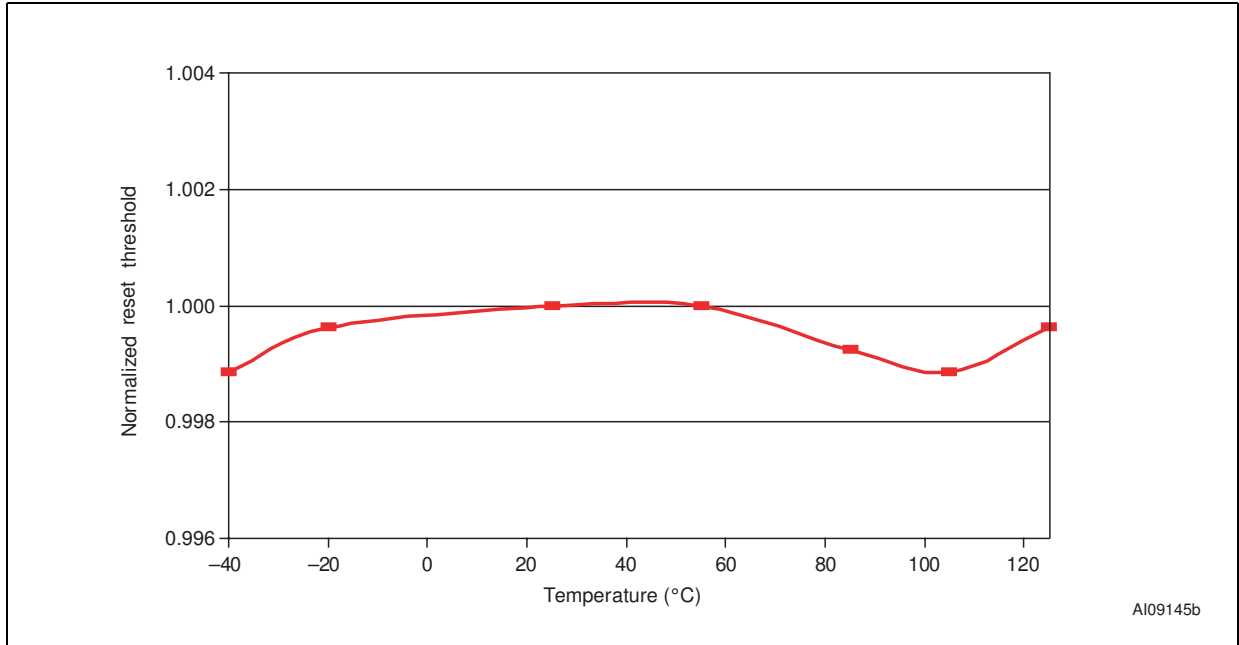

Figure 17. Watchdog timeout period vs. temperature

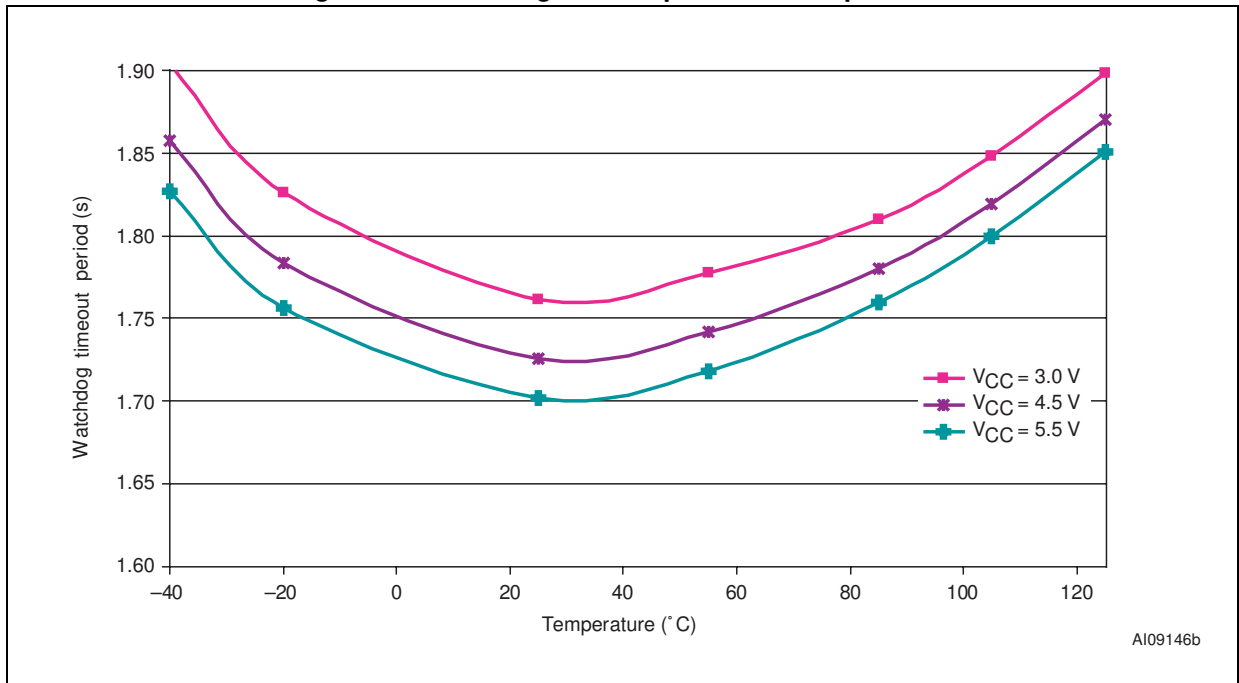

Figure 18. PFI to $\overline{\text{PFO}}$ propagation delay vs. temperature

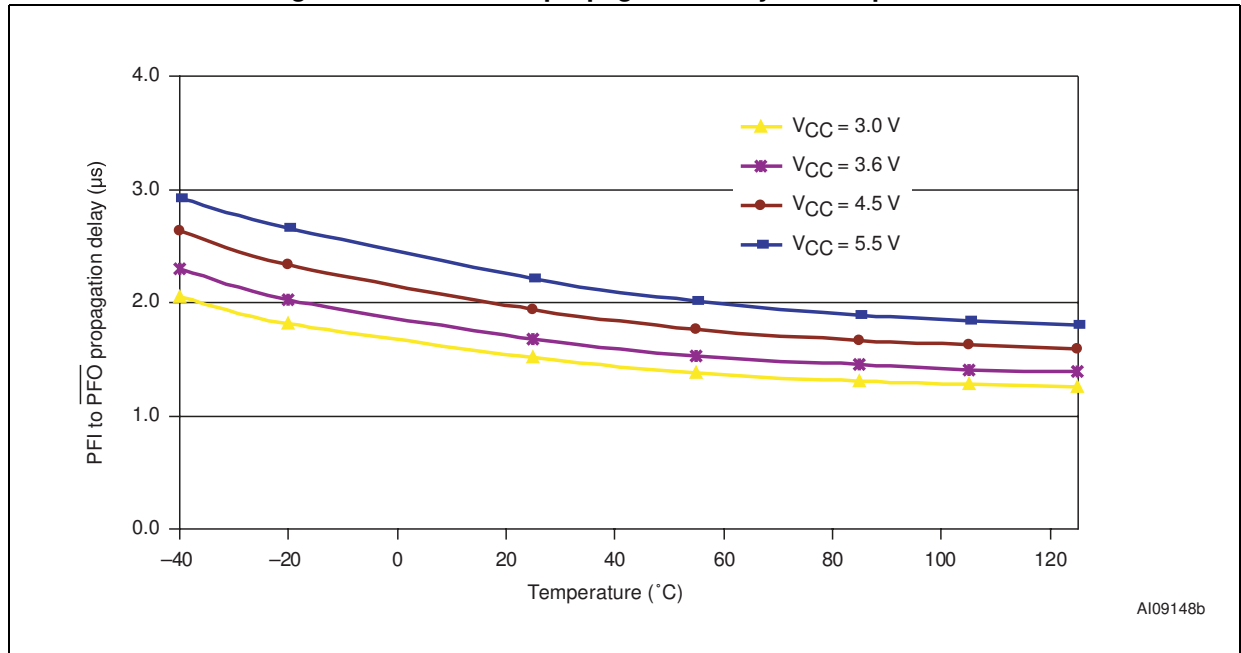

Figure 19. Output voltage vs. load current ($V_{CC} = 5\text{ V}$; $T_A = 25\text{ °C}$)

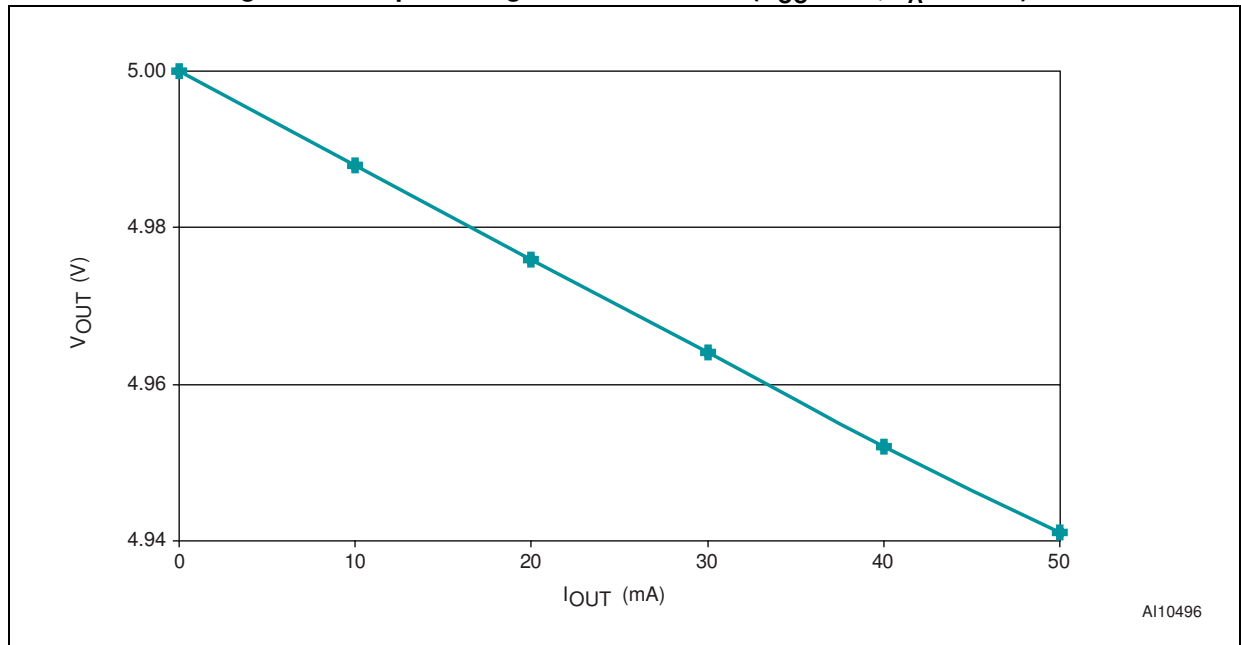

Figure 20. $\overline{\text{RST}}$ output voltage vs. supply voltage

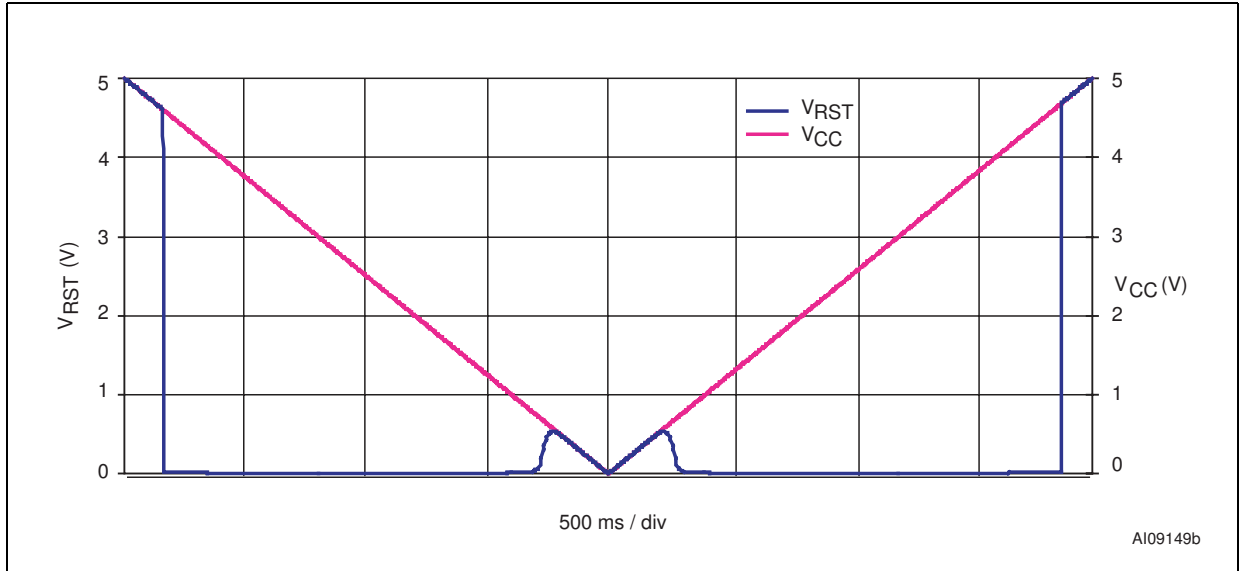

Figure 21. RST output voltage vs. supply voltage

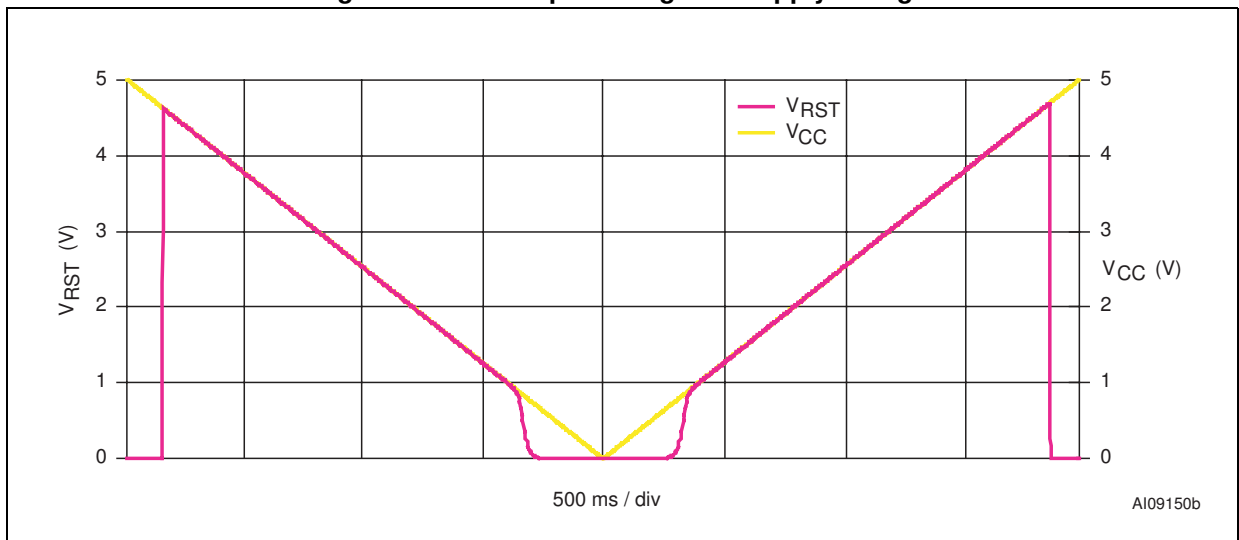

Figure 22. Power-fail comparator response time (assertion)

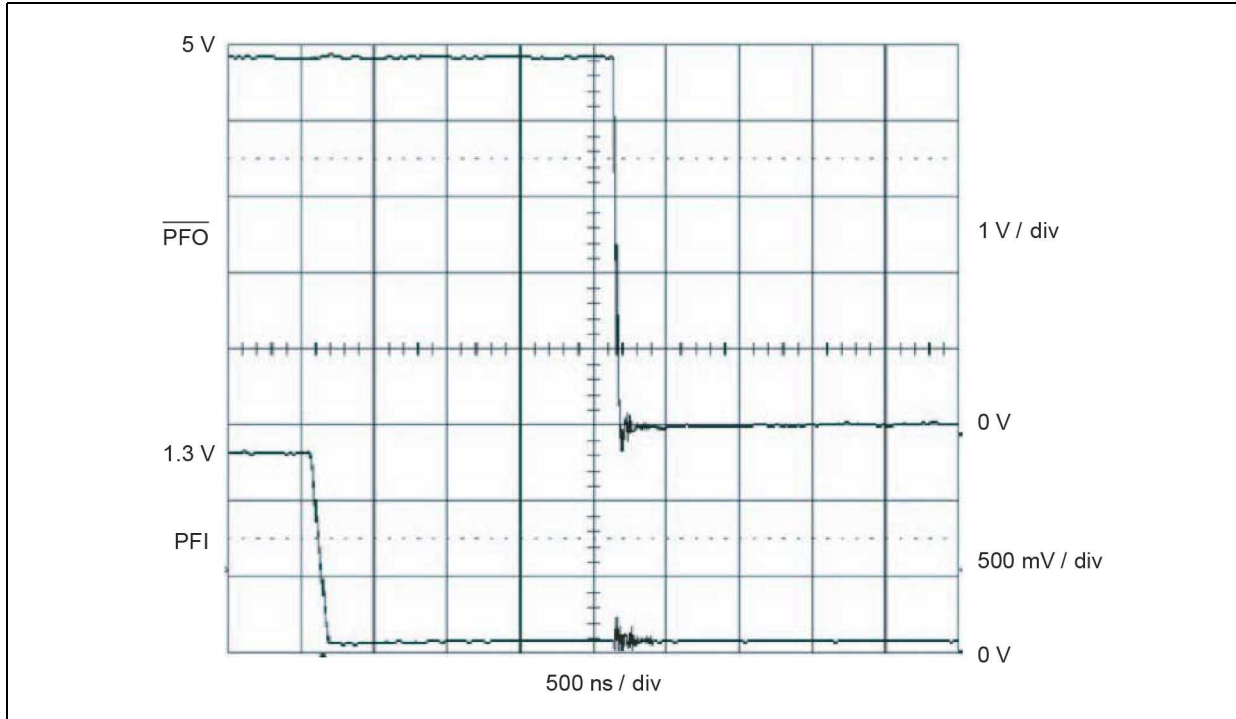

Figure 23. Power-fail comparator response time (de-assertion)

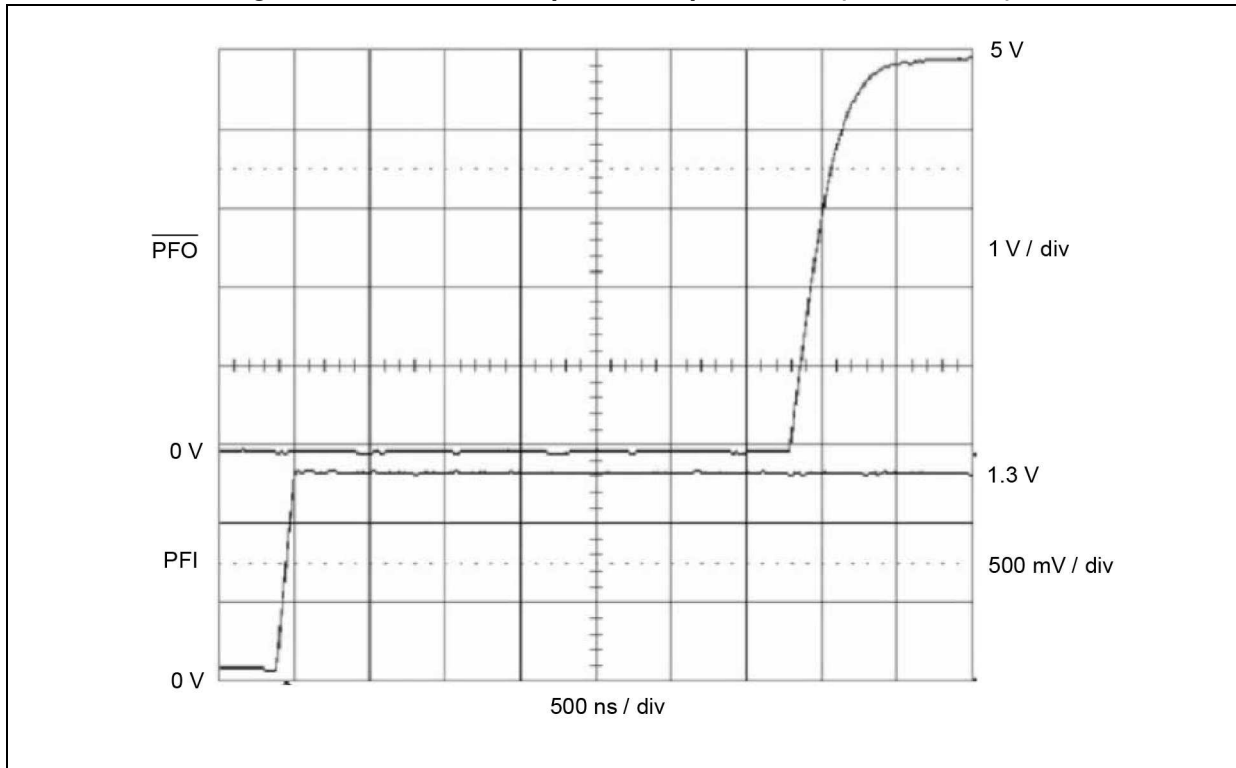
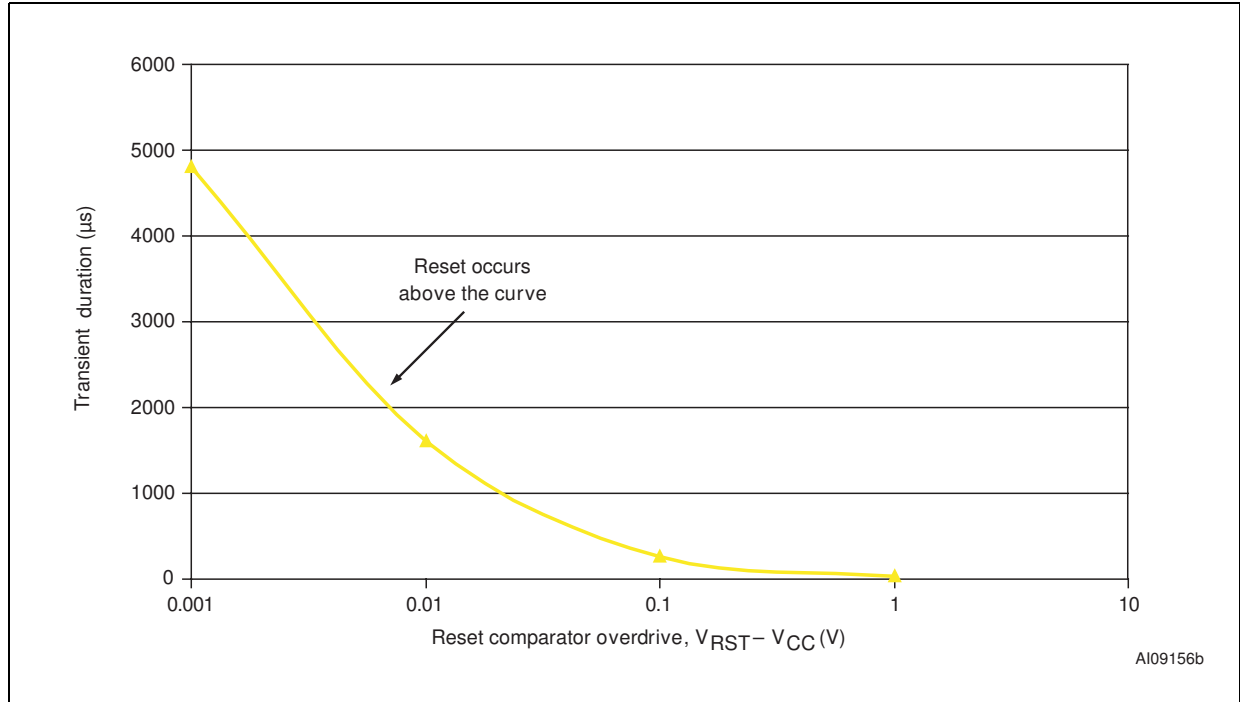

Figure 24. Maximum transient duration vs. reset threshold overdrive



5 Maximum ratings

Stressing the device above the rating listed in the [Table 4: Absolute maximum ratings](#) may cause permanent damage to the device. These are stress ratings only and operation of the device at these or any other conditions above those indicated in [Table 5: Operating and AC measurement conditions](#) of this specification is not implied. Exposure to absolute maximum rating conditions for extended periods may affect device reliability.

Table 4. Absolute maximum ratings

Symbol	Parameter	Value	Unit
T_{STG}	Storage temperature (V_{CC} off)	-55 to 150	°C
$T_{SLD}^{(1)}$	Lead solder temperature for 10 seconds	260	°C
$V_{IO}^{(2)}$	Input or output voltage	-0.3 to $V_{CC} + 0.3$	V
V_{CC}	Supply voltage	-0.3 to 7.0	V
I_O	Output current	20	mA
P_D	Power dissipation	320	mW

1. Reflow at peak temperature of 260 °C. The time above 255 °C must not exceed 30 seconds.
2. Negative undershoot of -1.5 V for up to 10 ns or positive overshoot of $V_{CC} + 1.5\text{ V}$ for up to 10 ns is allowable on the WDI and MR input pins.

6 DC and AC parameters

This section summarizes the operating measurement conditions, and the DC and AC characteristics of the device. The parameters in [Table 6: DC and AC characteristics](#) are derived from tests performed under the measurement conditions summarized in [Table 5: Operating and AC measurement conditions](#). Designers should check that the operating conditions in their circuit match the operating conditions when relying on the quoted parameters.

Table 5. Operating and AC measurement conditions

Parameter	STM70x	Unit
V_{CC} supply voltage	1.0 to 5.5	V
Ambient operating temperature (T_A)	-40 to 85	°C
Input rise and fall times	≤ 5	ns
Input pulse voltages	0.2 to 0.8 V_{CC}	V
Input and output timing ref. voltages	0.3 to 0.7 V_{CC}	V

Figure 25. AC testing input/output waveforms

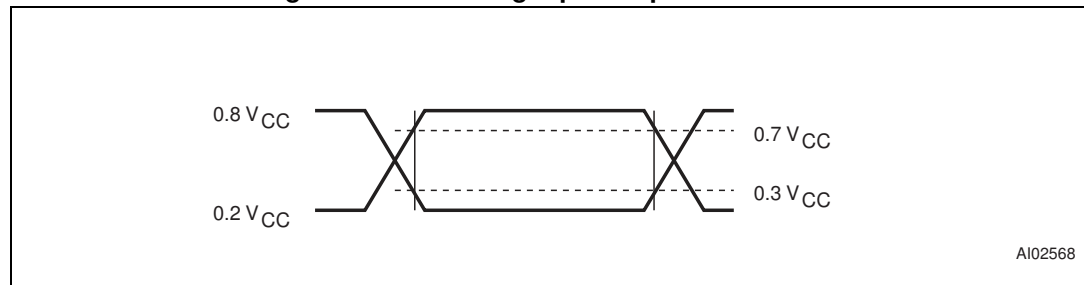

Figure 26. Power-fail comparator waveform

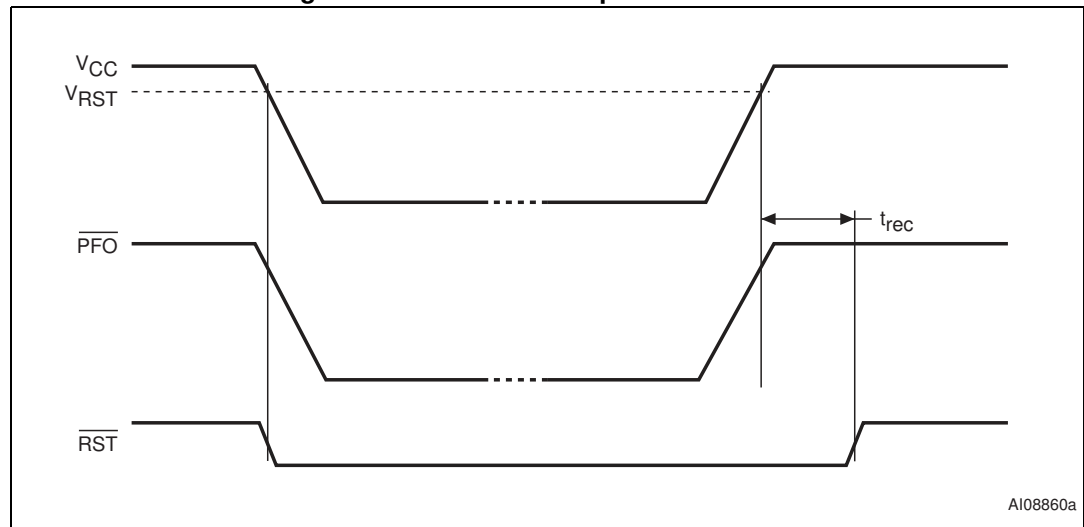
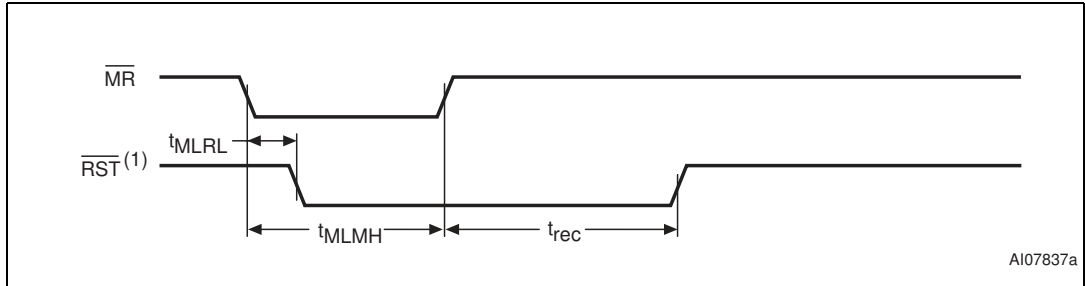

Figure 27. $\overline{\text{MR}}$ timing waveform



1. RST for STM706P and STM708T/S/R.

Figure 28. Watchdog timing (STM706T/S/R and STM706P)

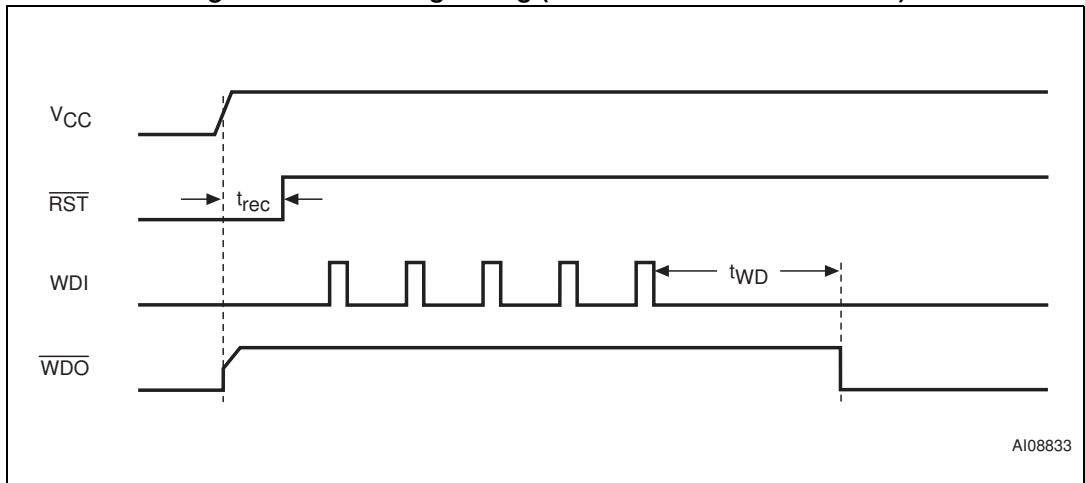

Table 6. DC and AC characteristics

Symbol	Description	Test condition ⁽¹⁾	Min.	Typ.	Max.	Unit
V_{CC}	Operating voltage		1.2 ⁽²⁾		5.5	V
I_{CC}	V_{CC} supply current	$V_{CC} < 3.6$ V		35	50	μ A
		$V_{CC} < 5.5$ V		40	60	μ A
I_{LI}	Input leakage current (WDI)	0 V < V_{IN} < V_{CC}	-1		+1	μ A
	Input leakage current (WDI) with watchdog disable feature ("D" version)	0 V < V_{IN} < V_{CC}	-110		110	μ A
	Input leakage current (PFI)	0 V < V_{IN} < V_{CC}	-25	2	+25	nA
	Input leakage current (MR)	$V_{RST} \text{ (max.)} < V_{CC} < 3.6$ V	25	80	250	μ A
4.5 V < $V_{CC} < 5.5$ V		75	125	300	μ A	
V_{IH}	Input high voltage (\overline{MR})	4.5 V < $V_{CC} < 5.5$ V	2.0			V
		$V_{RST} \text{ (max.)} < V_{CC} < 3.6$ V	$0.7 V_{CC}$			V
V_{IH}	Input high voltage (WDI)	$V_{RST} \text{ (max.)} < V_{CC} < 5.5$ V	$0.7 V_{CC}$			V
V_{IL}	Input low voltage (\overline{MR})	4.5 V < $V_{CC} < 5.5$ V			0.8	V
		$V_{RST} \text{ (max.)} < V_{CC} < 3.6$ V			0.6	V
V_{IL}	Input low voltage (WDI)	$V_{RST} \text{ (max.)} < V_{CC} < 5.5$ V			$0.3 V_{CC}$	V
V_{OL}	Output low voltage (\overline{PFO} , RST, RST, WDO)	$V_{CC} \geq V_{RST} \text{ (max.)}$, $I_{SINK} = 3.2$ mA			0.3	V
V_{OL}	Output low voltage (\overline{RST})	$I_{SINK} = 50$ μ A, $V_{CC} = 1.0$ V, $T_A = 0$ °C to 85 °C			0.3	V
		$I_{SINK} = 100$ μ A, $V_{CC} = 1.2$ V			0.3	V
V_{OH}	Output high voltage (\overline{RST} , RST, WDO)	$I_{SOURCE} = 1$ mA, $V_{CC} = V_{RST} \text{ (max.)}$	2.4			V
	Output high voltage (\overline{PFO})	$I_{SOURCE} = 75$ μ A, $V_{CC} \geq V_{RST} \text{ (max.)}$	$0.8 V_{CC}$			V
Power-fail comparator						
V_{PFI}	PFI input threshold	PFI falling (STM70xP/R, $V_{CC} = 3.0$ V; STM70xS/T, $V_{CC} = 3.3$ V)	1.20	1.25	1.30	V
t_{PFD}	PFI to \overline{PFO} propagation delay			2		μ s

Table 6. DC and AC characteristics (continued)

Symbol	Description	Test condition ⁽¹⁾	Min.	Typ.	Max.	Unit
Reset thresholds						
V_{RST}	Reset threshold ⁽³⁾	STM706P/70xR	2.55	2.63	2.70	V
		STM70xS	2.85	2.93	3.00	V
		STM70xT	3.00	3.08	3.15	V
	Reset threshold hysteresis			20		mV
t_{rec}	\overline{RST} pulse width	Blank (see Table 9)	140	200	280	ms
		A ⁽⁴⁾ (see Table 9)	160	200	280	
Push-button reset input						
t_{MLMH} (or t_{MR})	\overline{MR} pulse width	$V_{RST} (max.) < V_{CC} < 3.6 V$	500			ns
		$4.5 V < V_{CC} < 5.5 V$	150			ns
t_{MLRL} (or t_{MRD})	\overline{MR} to \overline{RST} output delay	$V_{RST} (max.) < V_{CC} < 3.6 V$			750	ns
		$4.5 V < V_{CC} < 5.5 V$			250	ns
Watchdog timer (STM706T/S/R and STM706P)						
t_{WD}	Watchdog timeout period	STM706P/70xR, $V_{CC} = 3.0 V$	1.12	1.60	2.24	s
		STM70xS/70XT, $V_{CC} = 3.3 V$				
	WDI pulse width	$4.5 V < V_{CC} < 5.5 V$	50			ns
		$V_{RST} (max.) < V_{CC} < 3.6 V$	100			ns

- Valid for ambient operating temperature: $T_A = -40$ to 85 °C; $V_{CC} = V_{RST} (max.)$ to $5.5 V$ (except where noted).
- $V_{CC} (min) = 1.0 V$ for $T_A = 0$ °C to $+85$ °C.
- For V_{CC} falling.
- STM706P/STM70xR device, $V_{CC} = 3 V$; STM706xS/STM70xT device, $V_{CC} = 3.3 V$.

7 Package information

In order to meet environmental requirements, ST offers these devices in different grades of ECOPACK packages, depending on their level of environmental compliance. ECOPACK specifications, grade definitions and product status are available at: www.st.com. ECOPACK is an ST trademark.

7.1 SO8 package information

Figure 29. SO8 - 8-lead plastic small outline, 150 mils body width, package outline

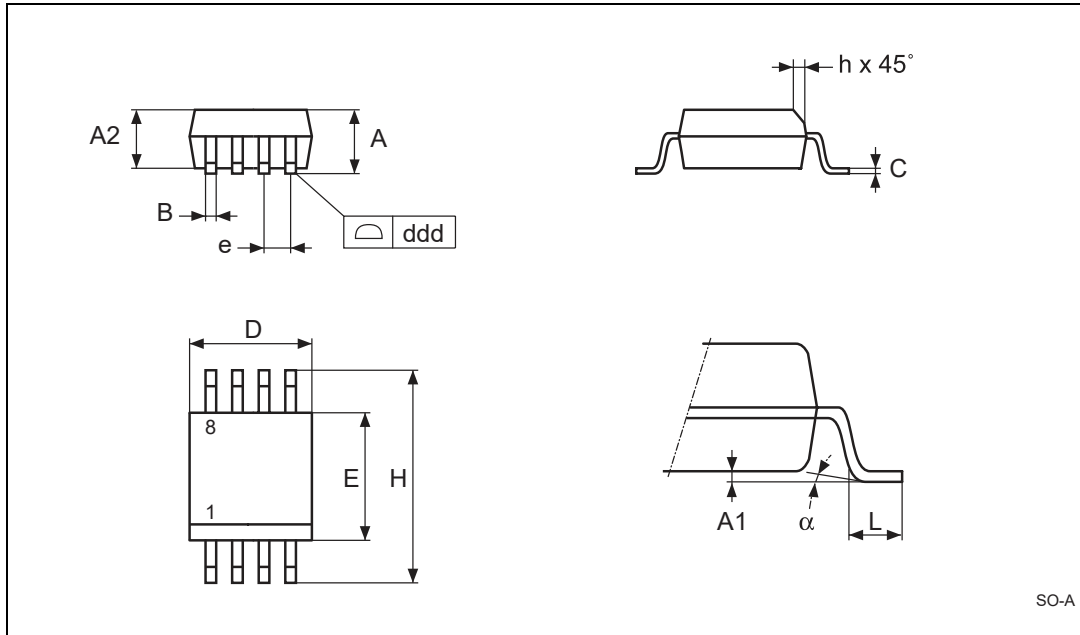

Note: Drawing is not to scale.

Table 7. SO8 - 8-lead plastic small outline, 150 mils body width, mechanical data

Symbol	Dimensions					
	mm			inches		
	Typ.	Min.	Max.	Typ.	Min.	Max.
A	—	1.35	1.75	—	0.053	0.069
A1	—	0.10	0.25	—	0.004	0.010
B	—	0.33	0.51	—	0.013	0.020
C	—	0.19	0.25	—	0.007	0.010
D	—	4.80	5.00	—	0.189	0.197
ddd	—	—	0.10	—	—	0.004
E	—	3.80	4.00	—	0.150	0.157
e	1.27	—	—	0.050	—	—
H	—	5.80	6.20	—	0.228	0.244
h	—	0.25	0.50	—	0.010	0.020
L	—	0.40	0.90	—	0.016	0.035
a	—	0°	8°	—	0°	8°
N	8	8				

7.2 TSSOP8 3x3 (DS) package information

Figure 30. TSSOP8 - 8-lead, thin shrink small outline, 3 x 3 mm body size, package outline

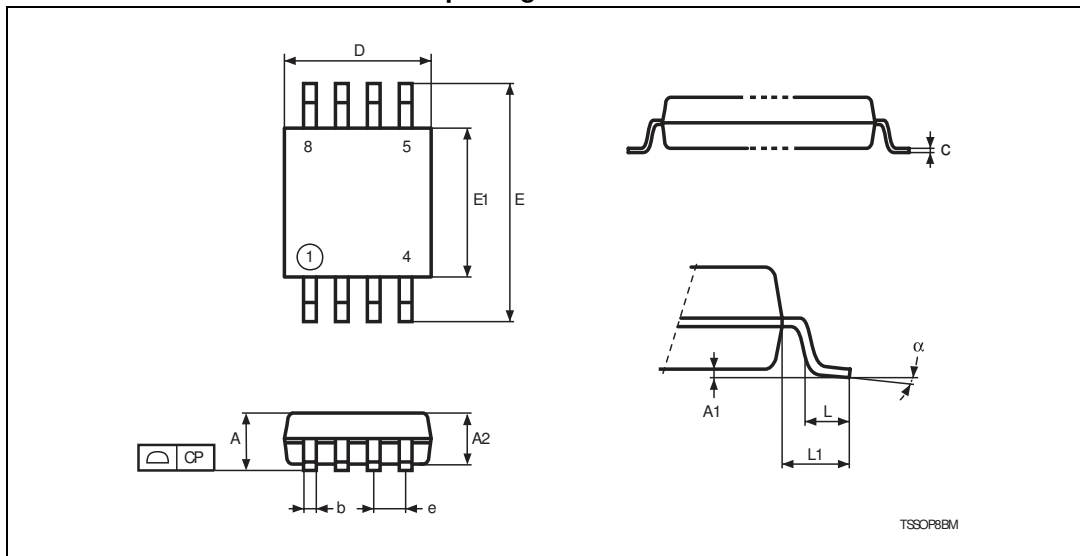

Note: Drawing is not to scale.

Table 8. TSSOP8 - 8-lead, thin shrink small outline, 3 x 3 mm body size, mechanical data

Symbol	Dimensions					
	mm			inches		
	Typ.	Min.	Max.	Typ.	Min.	Max.
A	—	—	1.10	—	—	0.043
A1	—	0.05	0.15	—	0.002	0.006
A2	0.85	0.75	0.95	0.034	0.030	0.037
b	—	0.25	0.40	—	0.010	0.016
c	—	0.13	0.23	—	0.005	0.009
CP	—	—	0.10	—	—	0.004
D	3.00	2.90	3.10	0.118	0.114	0.122
e	0.65	—	—	0.026	—	—
E	4.90	4.65	5.15	0.193	0.183	0.203
E1	3.00	2.90	3.10	0.118	0.114	0.122
L	0.55	0.40	0.70	0.022	0.016	0.030
L1	0.95	—	—	0.037	—	—
a	—	0°	6°	—	0°	6°
N	8	8				

8 Part numbering

Table 9. Ordering information scheme

Example:	STM706	T	D	M	6	F
Device type						
STM706						
STM708						
Reset threshold voltage						
T: $3.00\text{ V} \leq V_{\text{RST}} \leq 3.15\text{ V}$						
S: $2.88\text{ V} \leq V_{\text{RST}} \leq 3.00\text{ V}$						
R: STM706P: $2.59\text{ V} \leq V_{\text{RST}} \leq 2.70\text{ V}$						
Watchdog disable						
Blank = not activated						
D = activated						
RST pulse width						
Blank = 140 to 280 ms						
A ⁽¹⁾ = 160 to 280 ms						
Package						
M = SO8						
DS ⁽²⁾ = TSSOP8						
Temperature range						
6 = -40 to 85 °C						
Shipping method						
F = ECOPACK [®] packages, tape and reel						

1. Available in SO8 (M) package only

2. Contact local ST sales office for availability

For other options, or for more information on any aspect of this device, please contact the ST sales office nearest you.

Table 10. Marking description

Part number	Reset threshold	Package	Topside marking
STM706P	2.63 V	SO8	706P
		TSSOP8	
STM706T	3.08 V	SO8	706T
		TSSOP8	
STM706S	2.93 V	SO8	706S
		TSSOP8	
STM706R	2.63 V	SO8	706R
		TSSOP8	
STM706RD	2.63 V	SO8	706RD
		TSSOP8	
STM708T	3.08 V	SO8	708T
		TSSOP8	
STM708S	2.93 V	SO8	708S
		TSSOP8	
STM708R	2.63 V	SO8	708R
		TSSOP8	

9 Revision history

Table 11. Document revision history

Date	Revision	Changes
Oct-2003	1	Initial release.
12-Dec-2003	2	Reformatted; update characteristics (Figure 2, 3, 8 to 10, 27 to 29; Table 6 to 9).
16-Jan-2004	2.1	Add Typical operating characteristics (Figure 13, to 19, 21, to 25).
09-Apr-2004	3	Reformatted; update characteristics (Figure 15, 19, 21, 22, 25; Table 8).
25-May-2004	4	Update characteristics (Table 3, Table 6).
02-Jul-2004	5	Datasheet promoted; waveform corrected (Table 27).
21-Sep-2004	6	Clarify root part numbers; (Figure 2, to 10, 29; Table 1, 3, 6, 9).
25-Feb-2005	7	Update typical characteristics (Figure 13 to 25).
02-Nov-2009	8	Updated Table 1, Table 3, Table 4, Table 6, Table 9, Section 2.3, Section 2.7, text in Section 7; reformatted document.
30-Apr-2010	9	Updated Table 4, corrected typo in Table 2, Section 2.3, Section 3, Section 5 and Section 6, Figure 17, Table 7 and Table 8.
06-Aug-2010	10	Updated Features, Section 4: Typical operating characteristics; Table 9.
06-Sep-2011	11	Updated Section 2.7, Section 5 and Disclaimer, minor typo modifications throughout the document.
21-Aug-2012	12	Added <i>Applications</i> , updated <i>Section 2.2</i> and <i>Section 2.3</i> , added note to <i>Section 3.3</i> , added cross-references in <i>Section 5</i> and <i>Section 6</i> , minor text corrections throughout document.
15-Dec-2015	13	Updated layout of cover page and Section 7: Package information. Added information about the watchdog disable function to Section 2.2: WDI, Table 6, Table 9, and Table 10. Table 9: removed the "E" option (tubes) from shipping method.
17-Jan-2024	14	Updated V_{OL} and V_{OH} test condition in Table 6 .

IMPORTANT NOTICE – PLEASE READ CAREFULLY

STMicroelectronics NV and its subsidiaries ("ST") reserve the right to make changes, corrections, enhancements, modifications, and improvements to ST products and/or to this document at any time without notice. Purchasers should obtain the latest relevant information on ST products before placing orders. ST products are sold pursuant to ST's terms and conditions of sale in place at the time of order acknowledgement.

Purchasers are solely responsible for the choice, selection, and use of ST products and ST assumes no liability for application assistance or the design of Purchasers' products.

No license, express or implied, to any intellectual property right is granted by ST herein.

Resale of ST products with provisions different from the information set forth herein shall void any warranty granted by ST for such product.

ST and the ST logo are trademarks of ST. For additional information about ST trademarks, please refer to www.st.com/trademarks. All other product or service names are the property of their respective owners.

Information in this document supersedes and replaces information previously supplied in any prior versions of this document.

© 2024 STMicroelectronics – All rights reserved

OUR CERTIFICATE

DiGi provide top-quality products and perfect service for customer worldwide through standardization, technological innovation and continuous improvement. DiGi through third-party certification, we strictly control the quality of products and services. Welcome your RFQ to

Email: Info@DiGi-Electronics.com



Tel: +00 852-30501935

RFQ Email: Info@DiGi-Electronics.com

DiGi is a global authorized distributor of electronic components.