

STTH20R04D Datasheet



<https://www.DiGi-Electronics.com>

DiGi Electronics Part Number	STTH20R04D-DG
Manufacturer	STMicroelectronics
Manufacturer Product Number	STTH20R04D
Description	DIODE GEN PURP 400V 20A TO220AC
Detailed Description	Diode 400 V 20A Through Hole TO-220AC

This model STTH20R04D is available at DiGi Electronics.

DiGi Electronics offers a global database of semiconductor and electronic component datasheets.

We welcome your inquiries regarding pricing, lead time, or other product-related questions.

 [Request a Quote](#)

 [Datasheet Search](#)



Tel: +00 852-30501935

RFQ Email: Info@DiGi-Electronics.com

DiGi is a global authorized distributor of electronic components.

Purchase and inquiry

Manufacturer Product Number:

STTH20R04D

Series:

-

Technology:

Standard

Current - Average Rectified (Io):

20A

Speed:

Fast Recovery =< 500ns, > 200mA (Io)

Current - Reverse Leakage @ Vr:

20 μ A @ 400 V

Mounting Type:

Through Hole

Supplier Device Package:

TO-220AC

Base Product Number:

STTH20

Manufacturer:

STMicroelectronics

Product Status:

Active

Voltage - DC Reverse (Vr) (Max):

400 V

Voltage - Forward (Vf) (Max) @ If:

1.7 V @ 20 A

Reverse Recovery Time (trr):

45 ns

Capacitance @ Vr, F:

-

Package / Case:

TO-220-2

Operating Temperature - Junction:

175°C (Max)

Environmental & Export classification

RoHS Status:

ROHS3 Compliant

REACH Status:

REACH Unaffected

HTSUS:

8541.10.0080

Moisture Sensitivity Level (MSL):

1 (Unlimited)

ECCN:

EAR99

High efficiency rectifier

Datasheet - production data

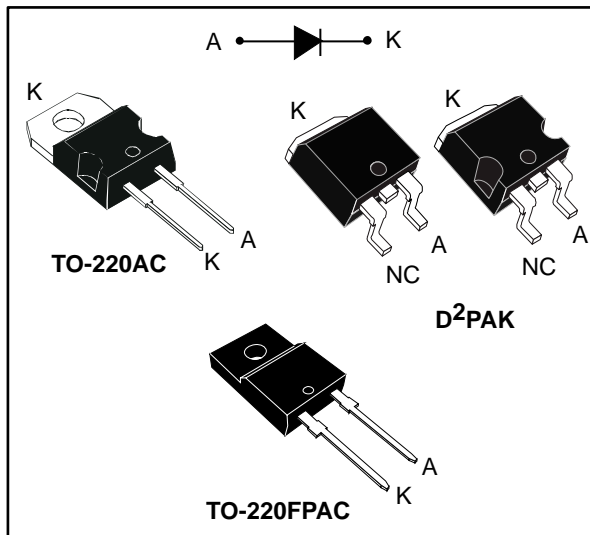

Description

This device is an ultrafast recovery power rectifier dedicated to energy recovery in PDP applications.

Especially designed for the clamping function in energy recovery blocks, the performance is optimized thanks to a compromise between forward voltage drop and recovery time.

Table 1: Device summary

Symbol	Value
$I_{F(AV)}$	20 A
V_{RRM}	400 V
T_j (max.)	175 °C
V_F (typ.)	1.15 V
t_{rr} (typ.)	18 ns

Features

- Ultrafast recovery
- Low power losses
- High surge capability
- Low leakage current
- High junction temperature
- Insulated package: TO-220FPAC
 - insulating voltage: 2000 V_{RMS} sine
- ECOPACK®2 compliant component for D²PAK on demand

1 Characteristics

Table 2: Absolute ratings (limiting values, at 25 °C, unless otherwise specified)

Symbol	Parameter		Value	Unit	
V_{RRM}	Repetitive peak reverse voltage		400	V	
$I_{F(RMS)}$	Forward rms current		50	A	
$I_{F(peak)}$	Peak working forward current $\delta = 0.5$, square wave	TO-220AC, D ² PAK	$T_C = 135\text{ °C}$	20	A
		TO-220FPAC	$T_C = 105\text{ °C}$		
I_{FSM}	Surge non repetitive forward current	$t_p = 10\text{ ms}$ sinusoidal		150	A
T_{stg}	Storage temperature range		-65 to +175	°C	
T_j	Maximum operating junction temperature		175	°C	

Table 3: Thermal parameter

Symbol	Parameter		Max. value	Unit
$R_{th(j-c)}$	Junction to case	TO-220AC, D ² PAK	2.8	°C/W
		TO-220FPAC	5	

Table 4: Static electrical characteristics

Symbol	Parameter	Test conditions		Min.	Typ.	Max.	Unit
$I_R^{(1)}$	Reverse leakage current	$T_j = 25\text{ °C}$	$V_R = V_{RRM}$	-		20	μA
		$T_j = 125\text{ °C}$		-	20	200	
$V_F^{(2)}$	Forward voltage drop	$T_j = 25\text{ °C}$	$I_F = 20\text{ A}$	-	1.50	1.70	V
		$T_j = 125\text{ °C}$		-	1.15	1.35	

Notes:

(1)Pulse test: $t_p = 5\text{ ms}$, $\delta < 2\%$

(2)Pulse test: $t_p = 380\text{ }\mu\text{s}$, $\delta < 2\%$

To evaluate the conduction losses use the following equation:

$$P = 1.05 \times I_{F(AV)} + 0.015 \times I_{F(RMS)}^2$$

Table 5: Dynamic electrical characteristics

Symbol	Parameter	Test conditions		Min.	Typ.	Max.	Unit
t_{rr}	Reverse recovery time	$T_j = 25\text{ °C}$	$I_F = 0.5\text{ A}$, $I_{rr} = 0.25\text{ A}$, $I_R = 1\text{ A}$	-	18	25	ns
			$I_F = 1\text{ A}$, $V_R = 30\text{ V}$, $di_F/dt = -50\text{ A}/\mu\text{s}$	-	35	45	
t_{fr}	Forward recovery time	$T_j = 25\text{ °C}$	$I_F = 20\text{ A}$, $di_F/dt = 100\text{ A}/\mu\text{s}$ $V_{FR} = 1.1 \times V_{Fmax}$	-		150	ns
V_{FP}	Forward recovery voltage		$I_F = 20\text{ A}$, $di_F/dt = 100\text{ A}/\mu\text{s}$	-	1.7	2.5	V
I_{RM}	Reverse recovery current		$I_F = 20\text{ A}$, $di_F/dt = -200\text{ A}/\mu\text{s}$	-	8	11	A
S_{factor}	Softness factor	$T_j = 125\text{ °C}$	$V_R = 200\text{ V}$	-	0.3		-

1.1 Characteristics (curves)

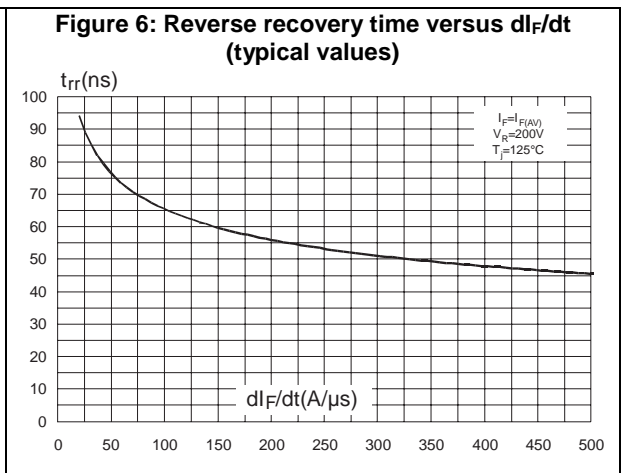
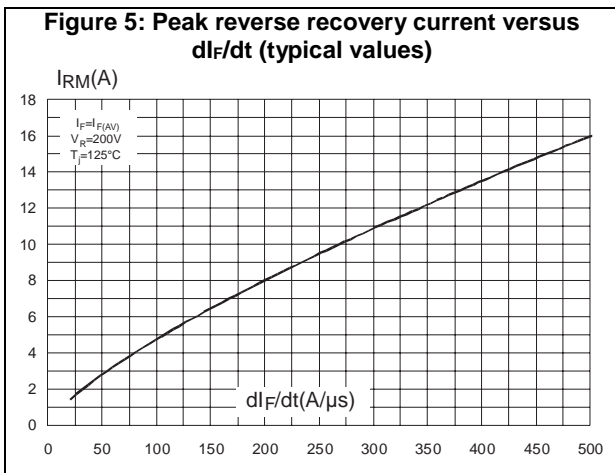
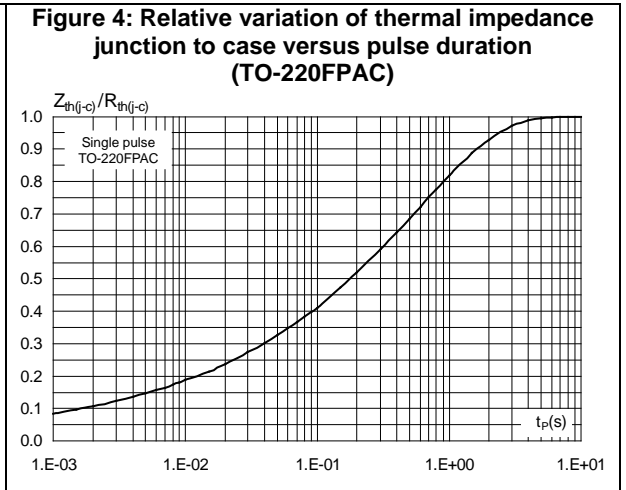
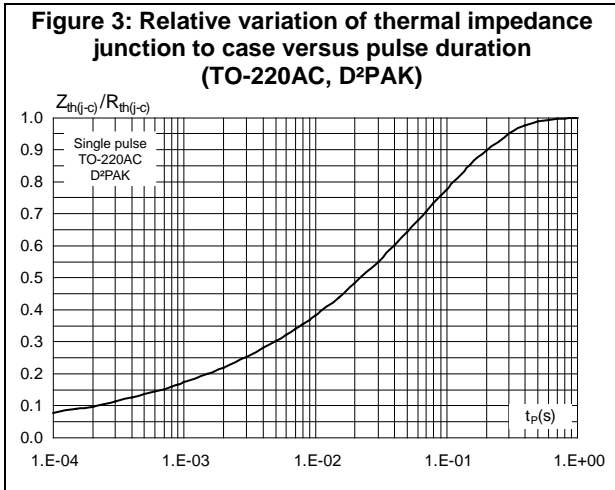
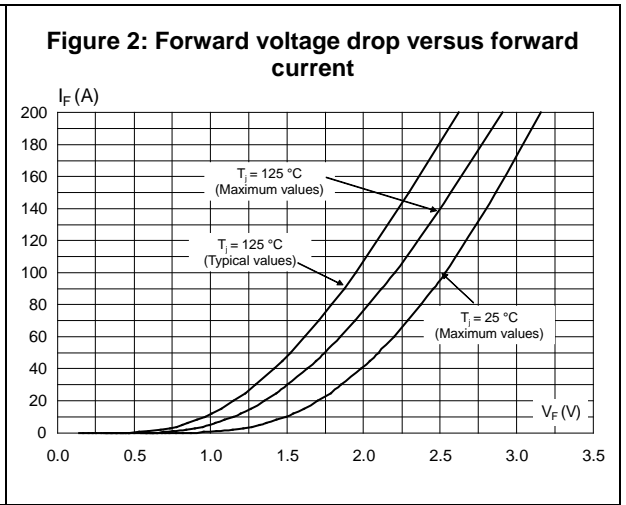
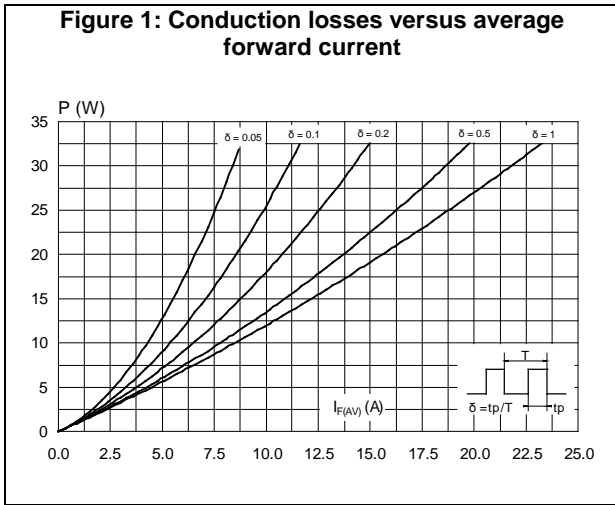

STTH20R04

Characteristics

Figure 7: Reverse recovery charges versus di_F/dt (typical values)

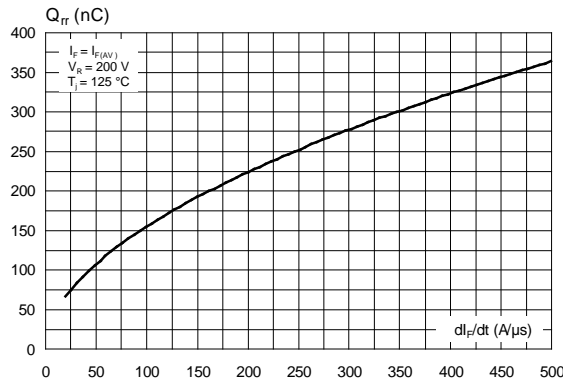

Figure 8: Reverse recovery softness factor versus di_F/dt (typical values)

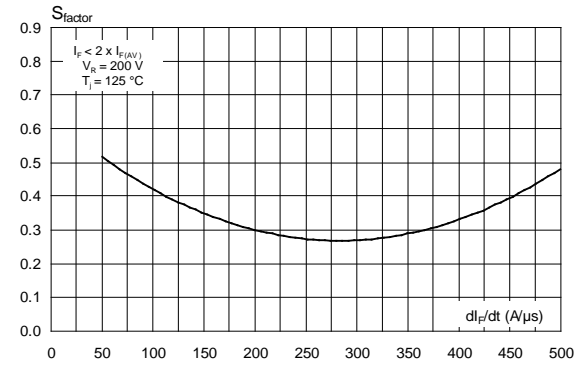

Figure 9: Relative variation of dynamic parameters versus junction temperature

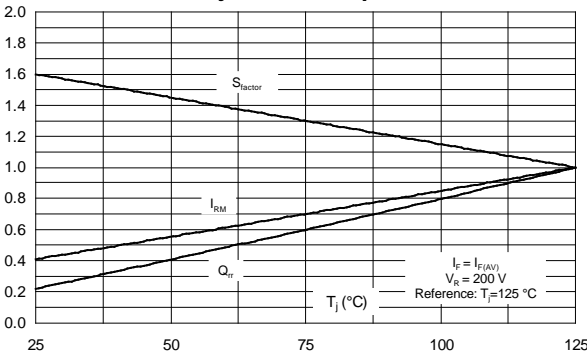

Figure 10: Transient peak forward voltage versus di_F/dt (typical values)

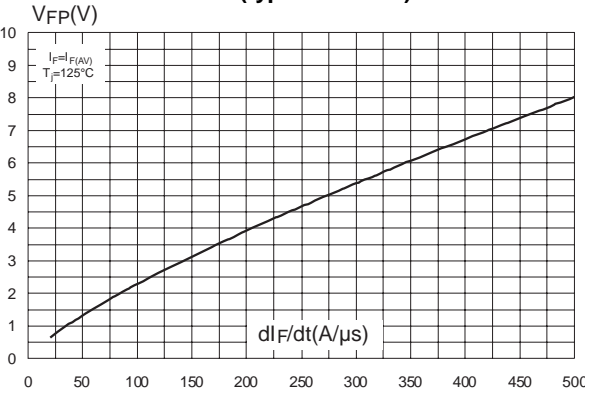

Figure 11: Forward recovery time versus di_F/dt (typical values)

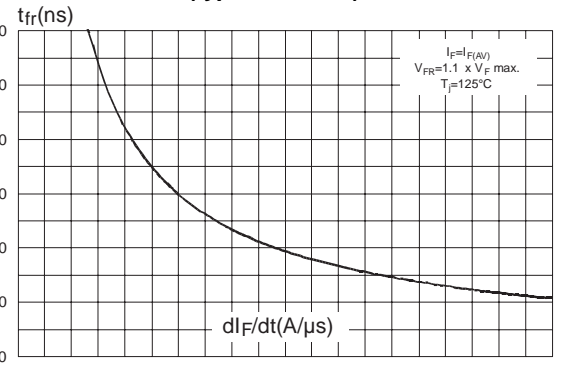

Figure 12: Junction capacitance versus reverse voltage applied (typical values)

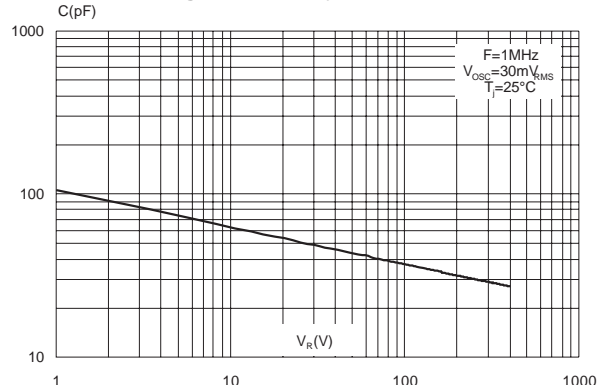
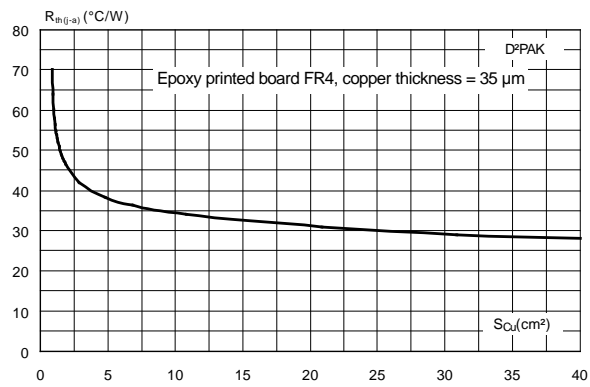
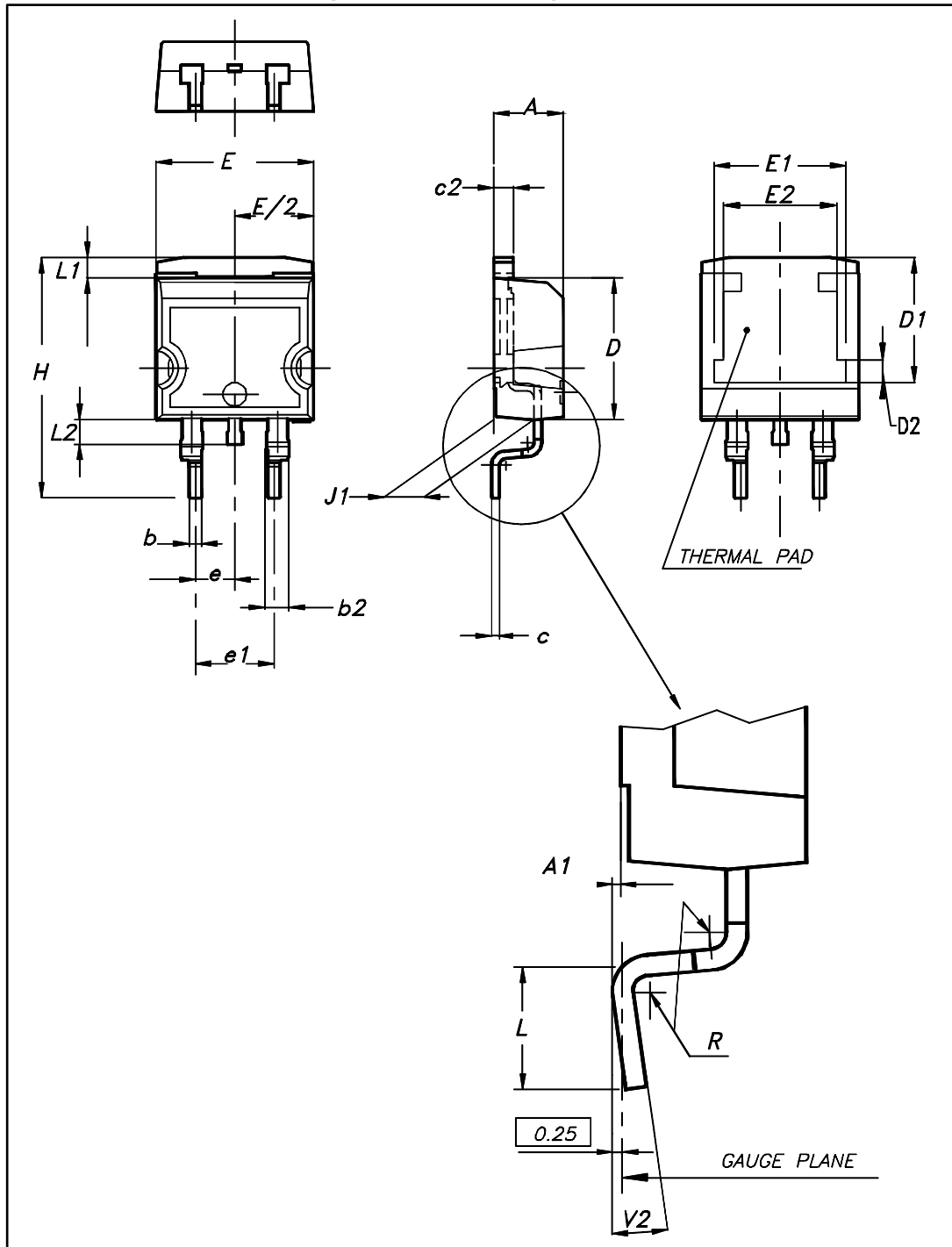

Figure 13: Thermal resistance junction to ambient versus copper surface under tab for D²PAK

2 Package information

In order to meet environmental requirements, ST offers these devices in different grades of ECOPACK® packages, depending on their level of environmental compliance. ECOPACK® specifications, grade definitions and product status are available at: www.st.com. ECOPACK® is an ST trademark.

- Cooling method: by conduction (C)
- Epoxy meets UL94,V0
- Recommended torque value: 0.55 N.m (for TO-220AC and TO-220FPAC)
- Maximum torque value: 0.70 N.m (for TO-220AC and TO-220FPAC)

2.1 D²PAK package informationFigure 14: D²PAK package outline

This package drawing may slightly differ from the physical package. However, all the specified dimensions are guaranteed.

Table 6: D²PAK package mechanical data

Ref.	Dimensions			
	Millimeters		Inches	
	Min.	Max.	Min.	Max.
A	4.36	4.60	0.172	0.181
A1	0.00	0.25	0.000	0.010
b	0.70	0.93	0.028	0.037
b2	1.14	1.70	0.045	0.067
c	0.38	0.69	0.015	0.027
c2	1.19	1.36	0.047	0.053
D	8.60	9.35	0.339	0.368
D1	6.90	8.00	0.272	0.311
D2	1.10	1.50	0.043	0.060
E	10.00	10.55	0.394	0.415
E1	8.10	8.90	0.319	0.346
E2	6.85	7.25	0.266	0.282
e	2.54 typ.		0.100	
e1	4.88	5.28	0.190	0.205
H	15.00	15.85	0.591	0.624
J1	2.49	2.90	0.097	0.112
L	1.90	2.79	0.075	0.110
L1	1.27	1.65	0.049	0.065
L2	1.30	1.78	0.050	0.070
R	0.4 typ.		0.015	
V2	0°	8°	0°	8°

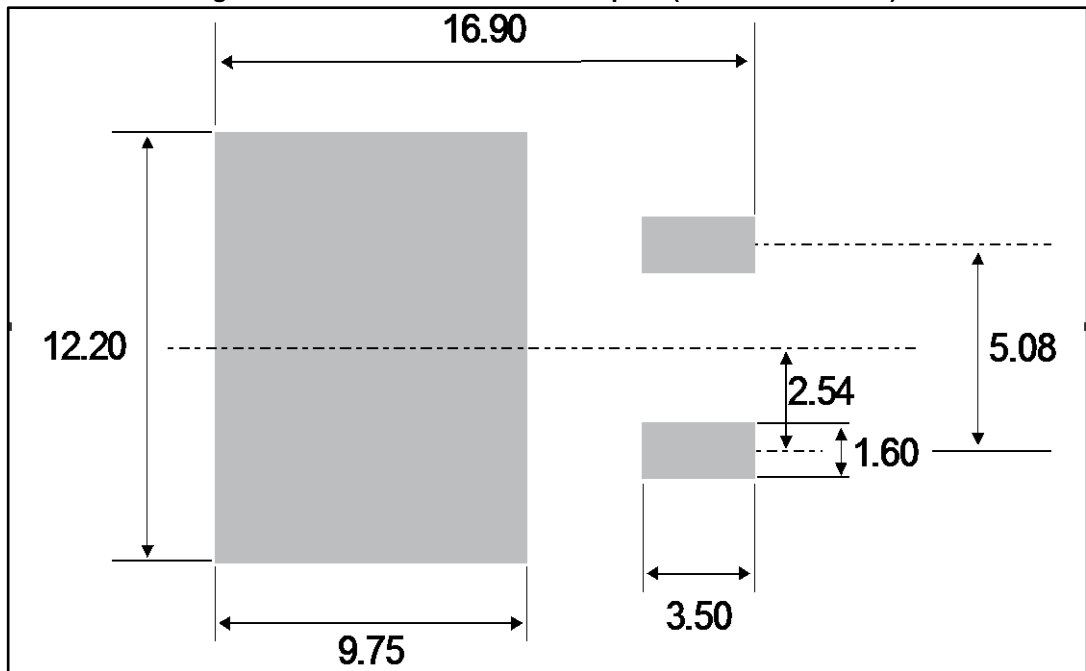
Figure 15: D²PAK recommended footprint (dimensions in mm)

2.2 TO-220AC package information

Figure 16: TO-220AC package outline

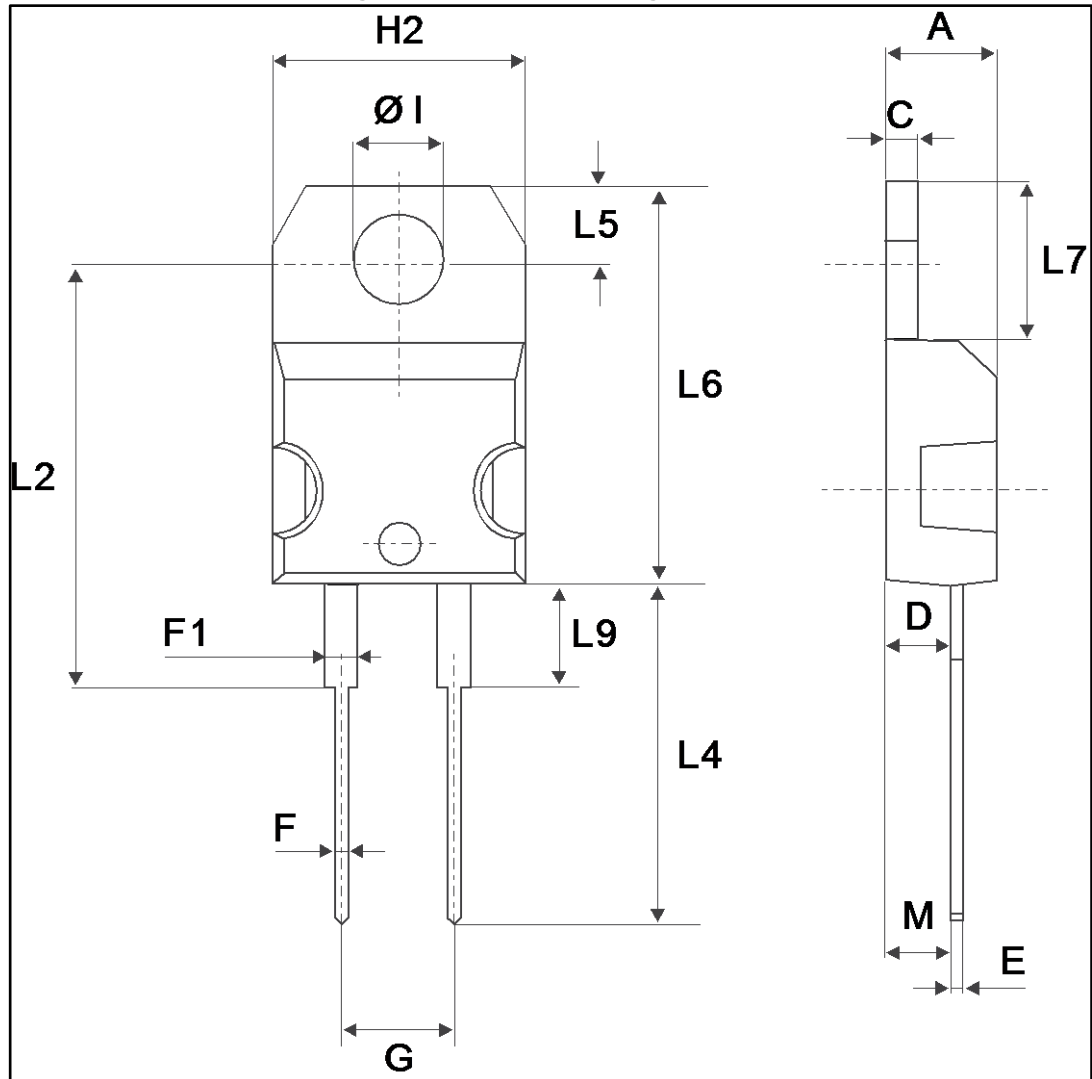

Table 7: TO-220AC package mechanical data

Ref.	Dimensions			
	Millimeters		Inches	
	Min.	Max.	Min.	Max.
A	4.40	4.60	0.173	0.181
C	1.23	1.32	0.048	0.051
D	2.40	2.72	0.094	0.107
E	0.49	0.70	0.019	0.027
F	0.61	0.88	0.024	0.034
F1	1.14	1.70	0.044	0.066
G	4.95	5.15	0.194	0.202
H2	10.00	10.40	0.393	0.409
L2	16.40 typ.		0.645 typ.	
L4	13.00	14.00	0.511	0.551
L5	2.65	2.95	0.104	0.116
L6	15.25	15.75	0.600	0.620
L7	6.20	6.60	0.244	0.259
L9	3.50	3.93	0.137	0.154
M	2.6 typ.		0.102 typ.	
ØI	3.75	3.85	0.147	0.151

2.3 TO-220FPAC package information

Figure 17: TO-220FPAC package outline

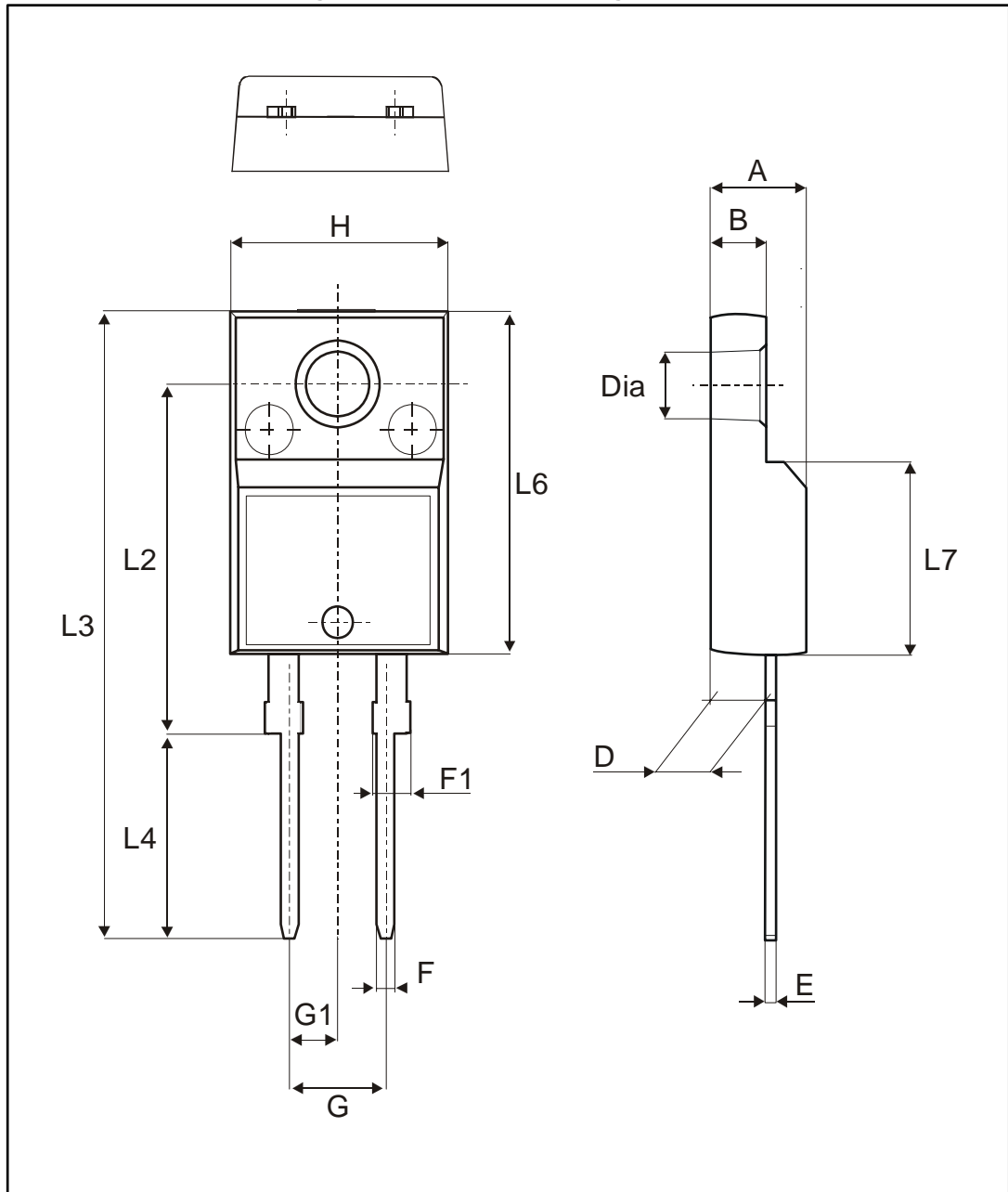

Table 8: TO-220FPAC package mechanical data

Ref.	Dimensions			
	Millimeters		Inches	
	Min.	Max.	Min.	Max.
A	4.40	4.60	0.173	0.181
B	2.50	2.70	0.098	0.106
D	2.50	2.75	0.098	0.108
E	0.45	0.70	0.018	0.027
F	0.75	1.00	0.030	0.039
F1	1.15	1.70	0.045	0.067
G	4.95	5.20	0.195	0.205
G1	2.40	2.70	0.094	0.106
H	10.00	10.40	0.393	0.409
L2	16.00 typ.		0.630 typ.	
L3	28.60	30.60	0.126	1.205
L4	9.80	10.60	0.386	0.417
L6	15.90	16.40	0.626	0.646
L7	9.00	9.30	0.354	0.366
Dia.	3.00	3.20	0.118	0.126

3 Ordering information

Table 9: Ordering information

Order code	Marking	Package	Weight	Base qty.	Delivery mode
STTH20R04G-TR	STTH20R04G	D ² PAK	1.38 g	1000	Tape and reel
STTH20R04FP	STTH20R04FP	TO-220FPAC	1.90 g	50	Tube
STTH20R04D	STTH20R04D	TO-220AC	1.87 g	50	Tube

4 Revision history

Table 10: Document revision history

Date	Revision	Changes
08-Nov-2007	1	First issue.
16-Aug-2017	2	Updated features and package silhouette. Updated Section 1: "Characteristics" , Section 1.1: "Characteristics (curves)" and Section 3: "Ordering information" .

IMPORTANT NOTICE – PLEASE READ CAREFULLY

STMicroelectronics NV and its subsidiaries ("ST") reserve the right to make changes, corrections, enhancements, modifications, and improvements to ST products and/or to this document at any time without notice. Purchasers should obtain the latest relevant information on ST products before placing orders. ST products are sold pursuant to ST's terms and conditions of sale in place at the time of order acknowledgement.

Purchasers are solely responsible for the choice, selection, and use of ST products and ST assumes no liability for application assistance or the design of Purchasers' products.

No license, express or implied, to any intellectual property right is granted by ST herein.

Resale of ST products with provisions different from the information set forth herein shall void any warranty granted by ST for such product.

ST and the ST logo are trademarks of ST. All other product or service names are the property of their respective owners.

Information in this document supersedes and replaces information previously supplied in any prior versions of this document.

© 2017 STMicroelectronics – All rights reserved

OUR CERTIFICATE

DiGi provide top-quality products and perfect service for customer worldwide through standardization, technological innovation and continuous improvement. DiGi through third-party certification, we stricly control the quality of products and services. Welcome your RFQ to

Email: Info@DiGi-Electronics.com



Tel: +00 852-30501935

RFQ Email: Info@DiGi-Electronics.com

DiGi is a global authorized distributor of electronic components.