

# STTH60AC06CW Datasheet



www.digi-electronics.com

<https://www.DiGi-Electronics.com>

DiGi Electronics Part Number	STTH60AC06CW-DG
Manufacturer	<a href="#">STMicroelectronics</a>
Manufacturer Product Number	STTH60AC06CW
Description	DIODE ARRAY GP 600V 30A TO247
Detailed Description	Diode Array 1 Pair Common Cathode 600 V 30A Through Hole TO-247-3

This model STTH60AC06CW is available at DiGi Electronics.

DiGi Electronics offers a global database of semiconductor and electronic component datasheets.

We welcome your inquiries regarding pricing, lead time, or other product-related questions.

 [Request a Quote](#)

 [Datasheet Search](#)



Tel: +00 852-30501935

RFQ Email: [Info@DiGi-Electronics.com](mailto:Info@DiGi-Electronics.com)

DiGi is a global authorized distributor of electronic components.

## Purchase and inquiry

Manufacturer Product Number:

STTH60AC06CW

Series:

-

Diode Configuration:

1 Pair Common Cathode

Voltage - DC Reverse (Vr) (Max):

600 V

Voltage - Forward (Vf) (Max) @ If:

1.75 V @ 30 A

Reverse Recovery Time (trr):

40 ns

Operating Temperature - Junction:

175°C (Max)

Package / Case:

TO-247-3

Base Product Number:

STTH60

Manufacturer:

STMicroelectronics

Product Status:

Active

Technology:

Standard

Current - Average Rectified (Io) (per Diode):

30A

Speed:

Fast Recovery =< 500ns, > 200mA (Io)

Current - Reverse Leakage @ Vr:

10 µA @ 600 V

Mounting Type:

Through Hole

Supplier Device Package:

TO-247

## Environmental & Export classification

RoHS Status:

ROHS3 Compliant

REACH Status:

REACH Unaffected

HTSUS:

8541.10.0080

Moisture Sensitivity Level (MSL):

1 (Unlimited)

ECCN:

EAR99

## Turbo 2 ultrafast high voltage rectifier

Datasheet – production data

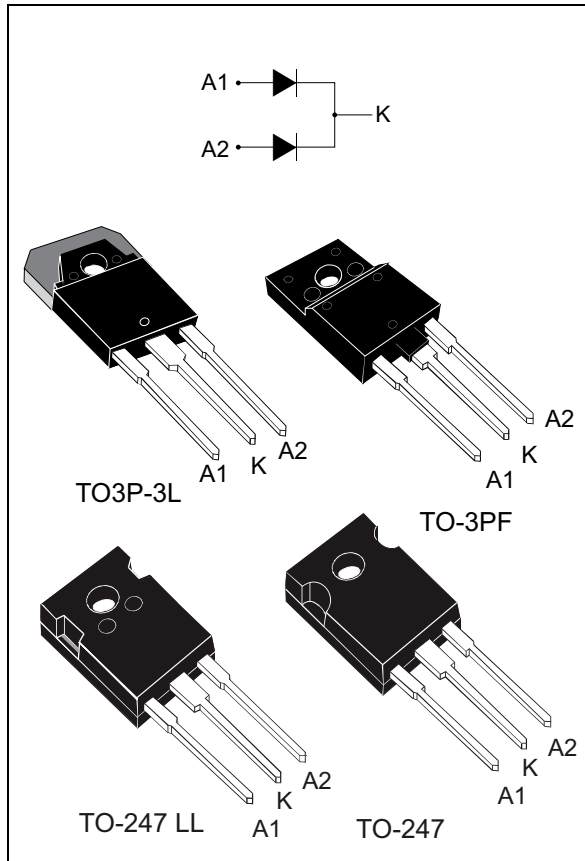

## Description

This device uses ST Turbo 2 600 V technology and is specially suited for use as a boost diode in air conditioning equipment as continuous mode interleaved power factor correction.

The device is also intended for use as a free wheeling diode in power supplies and other power switching applications.

Table 1. Device summary

Symbol	Value
$I_{F(AV)}$	2 x 30 A
$V_{RRM}$	600 V
$t_{rr}$ (typ)	40 ns
$V_F$ (typ)	1.4 V
$T_j$	175 °C

## Features

- Ultrafast switching
- Low reverse current
- Low thermal resistance
- Reduces switching and conduction losses
- Insulated package TO-3PF:
  - Insulated voltage: 2500 V<sub>DC</sub>

# 1 Characteristics

**Table 2. Absolute ratings (limiting values per diode at 25 °C, unless otherwise specified)**

Symbol	Parameter		Value	Unit
$V_{RRM}$	Repetitive peak reverse voltage		600	V
$I_{F(RMS)}$	Forward rms current		50	A
$I_{F(AV)}$	Average forward current	Per diode	30	A
		Per device	60	
$I_{FSM}$	Surge non repetitive forward current	$t_p = 10$ ms sinusoidal	280	A
$T_{stg}$	Storage temperature range		-65 to +175	°C
$T_j$	Maximum operating junction temperature		175	°C

**Table 3. Thermal parameters**

Symbol	Parameter		Value	Unit
$R_{th(j-c)}$	Junction to case (TO3P-3L, TO-247, TO-247 LL)	Per diode	0.9	°C/W
		Total	0.55	
$R_{th(c)}$	Coupling (TO3P-3L, TO-247, TO-247 LL)		0.2	
$R_{th(j-c)}$	Junction to case (TO-3PF)	Per diode	2.8	
		Total	2.2	
$R_{th(c)}$	Coupling (TO-3PF)		1.6	

**Table 4. Static electrical characteristics (per diode)**

Symbol	Parameter	Test conditions		Min.	Typ.	Max.	Unit
$I_R^{(1)}$	Reverse leakage current	$T_j = 25$ °C	$V_R = V_{RRM}$			10	μA
		$T_j = 150$ °C			40	400	
$V_F^{(2)}$	Forward voltage drop	$T_j = 25$ °C	$I_F = 30$ A			1.75	V
		$T_j = 150$ °C			1.07	1.40	
		$T_j = 25$ °C	$I_F = 60$ A			2	
		$T_j = 150$ °C			1.32	1.7	

1. Pulse test:  $t_p = 5$  ms,  $\delta < 2\%$

2. Pulse test:  $t_p = 380$  μs,  $\delta < 2\%$

To evaluate the conduction losses use the following equation:

$$P = 1.1 \times I_{F(AV)} + 0.01 I_{F(RMS)}^2$$

Table 5. Dynamic characteristics (per diode)

Symbol	Parameter	Test conditions		Min.	Typ.	Max.	Unit
$t_{rr}$	Reverse recovery time	$T_j = 25\text{ }^\circ\text{C}$	$I_F = 0.5\text{ A}$ , $I_{rr} = 0.25\text{ A}$ , $I_R = 1\text{ A}$			40	ns
			$I_F = 1\text{ A}$ , $V_R = 30\text{ V}$ , $di_F/dt = -50\text{ A}/\mu\text{s}$		50	70	
$I_{RM}$	Reverse recovery current	$T_j = 125\text{ }^\circ\text{C}$	$I_F = 30\text{ A}$ , $V_R = 400\text{ V}$ , $di_F/dt = -100\text{ A}/\mu\text{s}$		6.5	9	A
$t_{fr}$	Forward recovery time	$T_j = 25\text{ }^\circ\text{C}$	$I_F = 30\text{ A}$ , $V_{FR} = 1.5\text{ V}$ , $di_F/dt = +200\text{ A}/\mu\text{s}$			100	ns
$V_{FP}$	Forward recovery voltage				2.5		V

Figure 1. Average forward power dissipation versus average forward current (per diode)

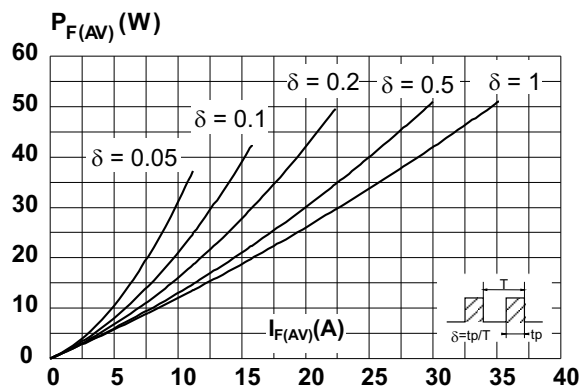

Figure 2. Forward voltage drop versus forward current (typical values, per diode)

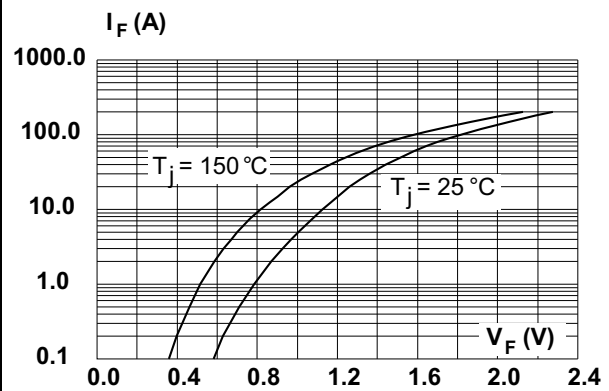

Figure 3. Forward voltage drop versus forward current (maximum values, per diode)

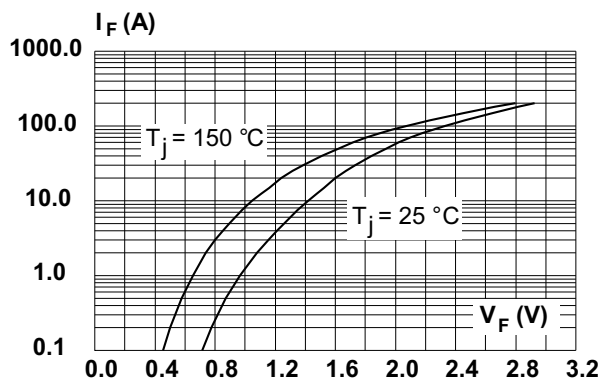

Figure 4. Relative variation of thermal impedance, junction to case, versus pulse duration (TO3P-3L, TO-247, TO-247LL)

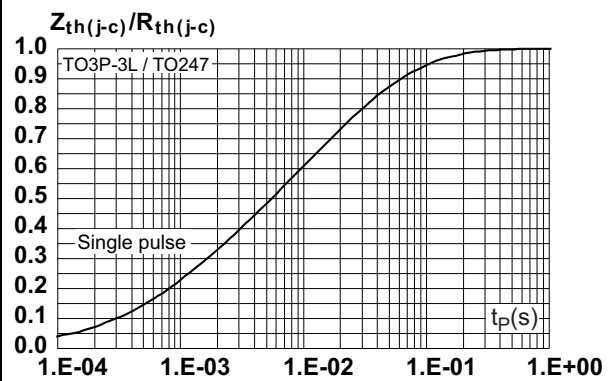

Figure 5. Relative variation of thermal impedance, junction to case, versus pulse duration (TO-3PF)

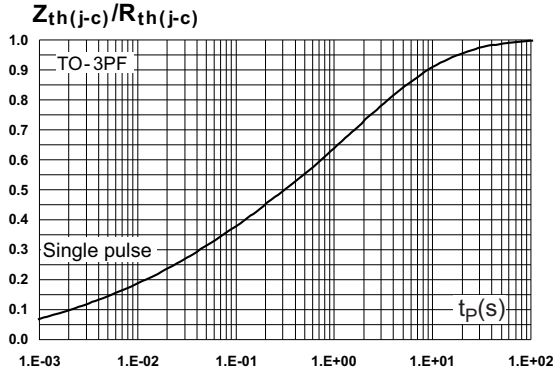

Figure 6. Peak reverse recovery current versus  $di_F/dt$  (typical values, per diode)

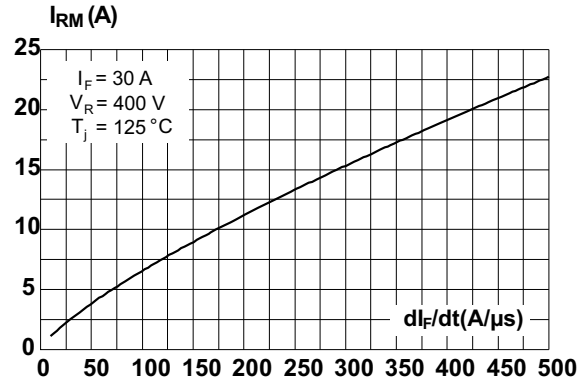

Figure 7. Reverse recovery time versus  $di_F/dt$  (typical values, per diode)

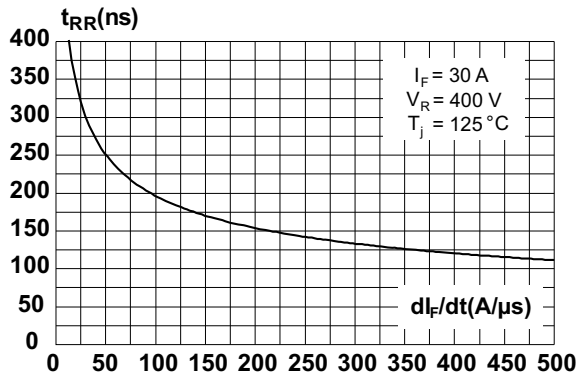

Figure 8. Reverse recovery charges versus  $di_F/dt$  (typical values, per diode)

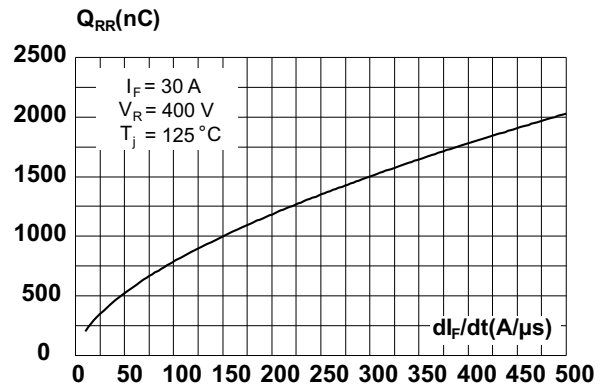

Figure 9. Reverse recovery softness factor versus  $di_F/dt$  (typical values, per diode)

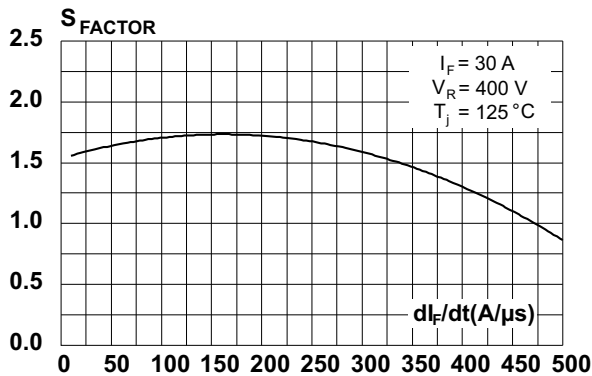

Figure 10. Relative variations of dynamic parameters versus junction temperature

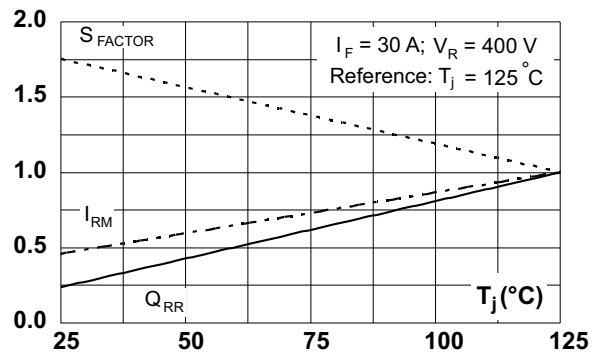

Figure 11. Transient peak forward voltage versus  $di_F/dt$  (typical values, per diode)

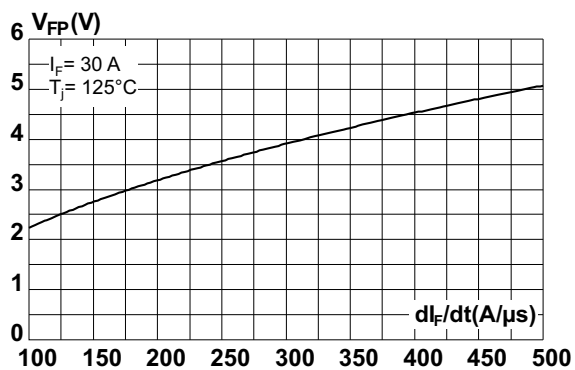

Figure 12. Forward recovery time versus  $di_F/dt$  (typical values, per diode)

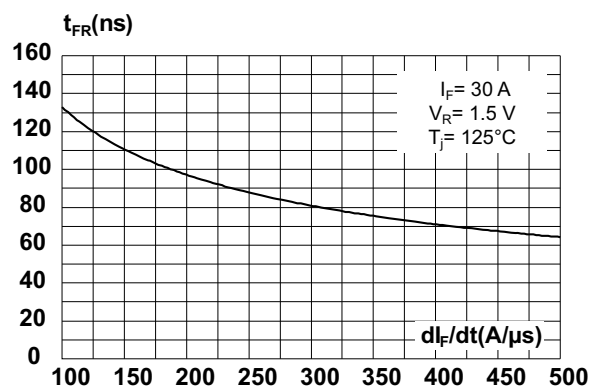
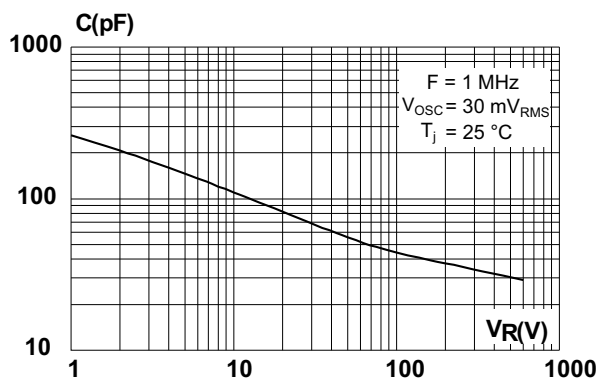

Figure 13. Junction capacitance versus reverse voltage applied (typical values, per diode)



## 2 Package information

- Epoxy meets UL94, V0
- Cooling method: by conduction (C)
- Recommended torque: (TO3P-3L, TO-3PF) 0.4 to 0.6 N·m, (TO-247) 0.5 to 1.0 N·m
- Maximum torque value (TO-247 LL): 1.0 N·m

In order to meet environmental requirements, ST offers these devices in different grades of ECOPACK<sup>®</sup> packages, depending on their level of environmental compliance. ECOPACK<sup>®</sup> specifications, grade definitions and product status are available at: [www.st.com](http://www.st.com). ECOPACK<sup>®</sup> is an ST trademark.

### 2.1 TO3P-3L package information

Figure 14. TO3P-3L package outline

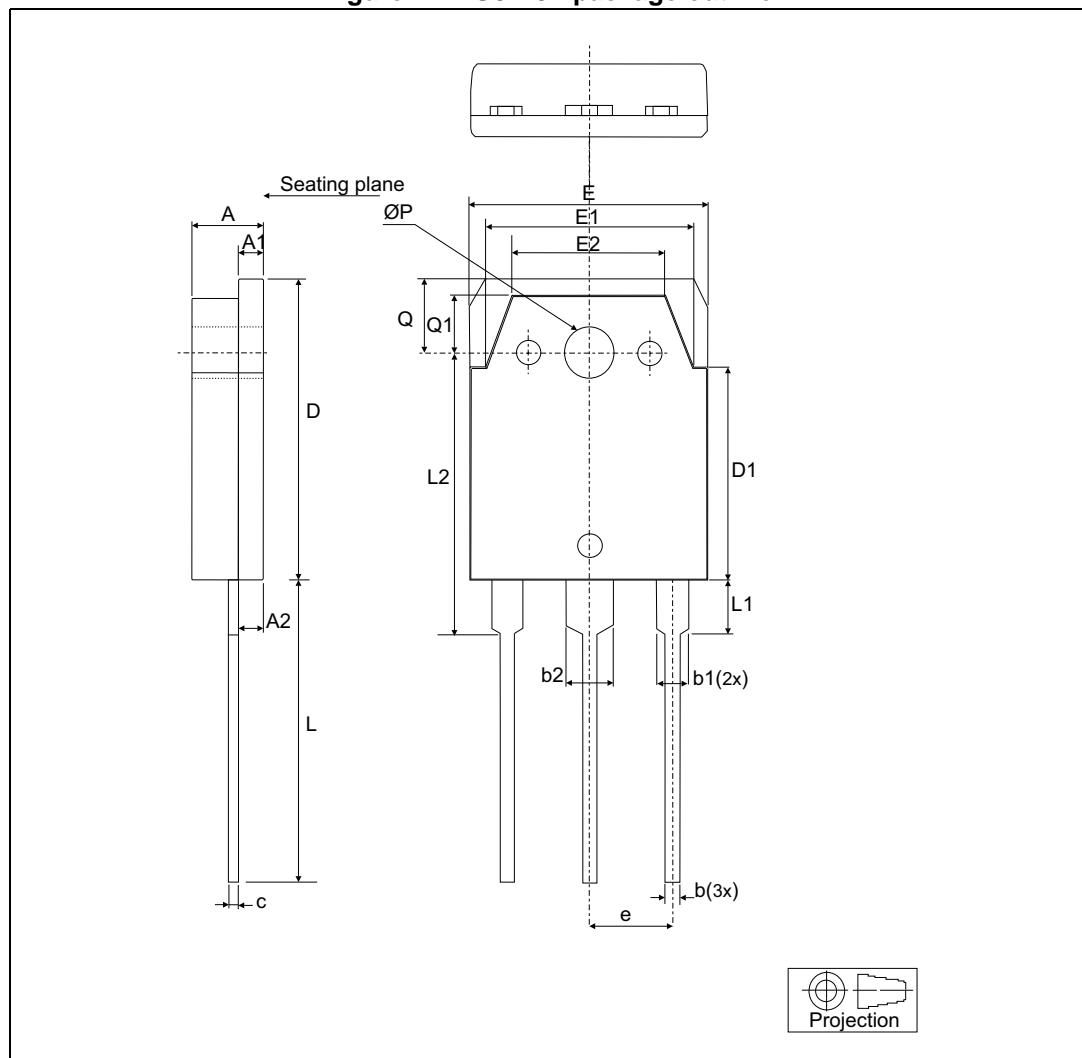

Table 6. TO3P-3L package mechanical data

Ref.	Dimensions					
	Millimeters			Inches		
	Min.	Typ.	Max.	Min.	Typ.	Max.
A	4.6		5	0.18		0.19
A1	1.45	1.5	1.65	0.05	0.06	0.06
A2	1.20	1.40	1.60	0.04	0.05	0.06
b	0.80	1	1.20	0.03	0.04	0.05
b1	1.80		2.20	0.07		0.08
b2	2.80		3.20	0.11		0.12
c	0.55	0.60	0.75	0.02	0.02	0.03
D	19.70	19.90	20.10	0.77	0.78	0.79
D1		13.90			0.54	
E	15.40		15.80	0.60		0.62
E1		13.60			0.53	
E2		9.60			0.38	
e	5.15	5.45	5.75	0.20	0.21	0.22
L	19.50	20	20.50	0.76	0.78	0.80
L1		3.50			0.14	
L2	18.20	18.40	18.60	0.71	0.72	0.73
ØP	3.10		3.30	0.12		0.13
Q		5			0.19	
Q1		3.80			0.15	

## 2.2 TO-3PF package information

Figure 15. TO-3PF package outline

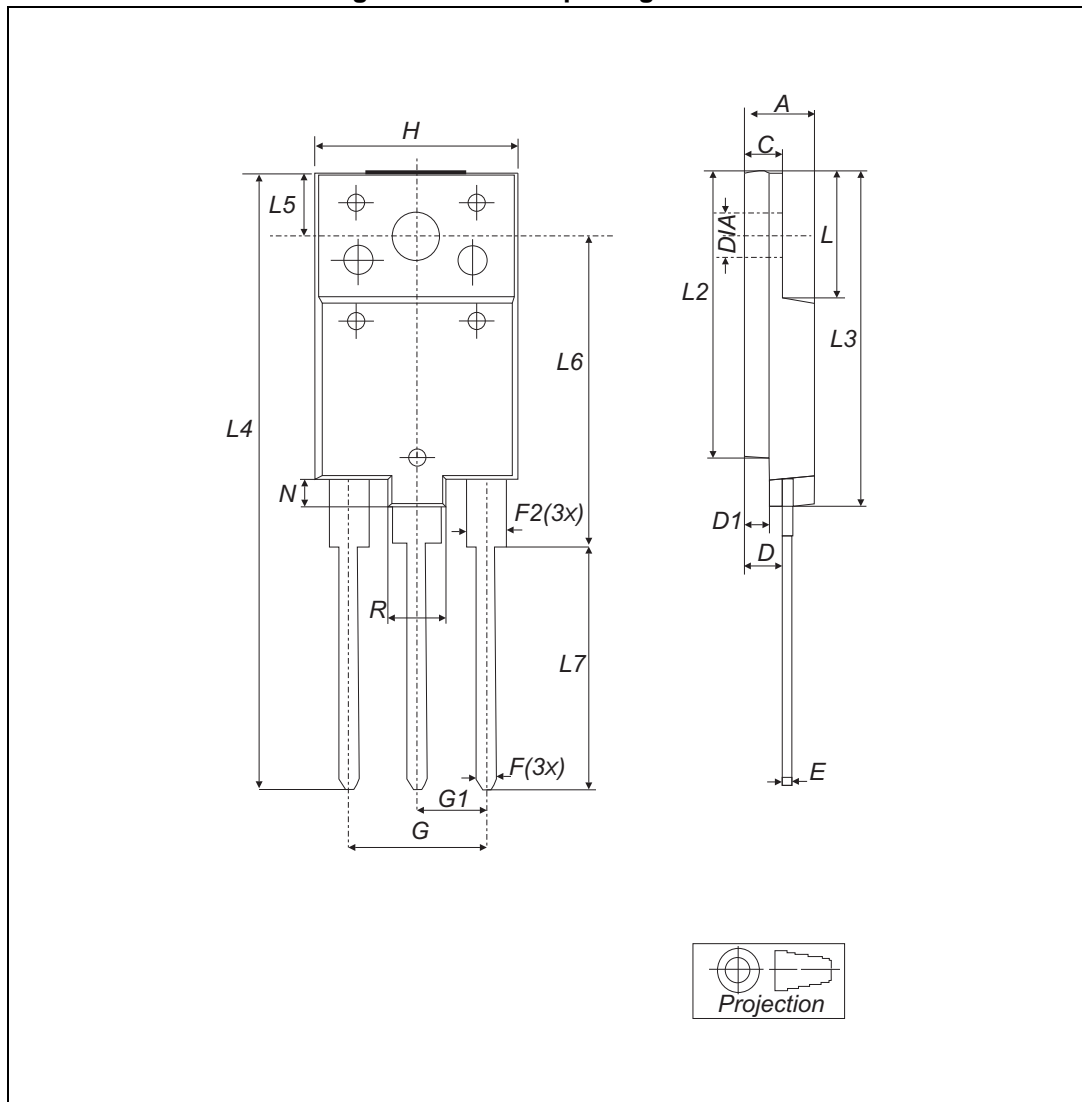

Table 7. TO-3PF mechanical data

Ref.	Dimensions					
	Millimeters			Inches		
	Min.	Typ.	Max.	Min.	Typ.	Max.
A	5.30		5.70	0.2		0.22
C	2.80		3.20	0.11		0.12
D	3.10		3.50	0.12		0.13
D1	1.80		2.20	0.07		0.08
E	0.80		1.10	0.03		0.04
F	0.65		0.95	0.025		0.037
F2	1.80		2.20	0.07		0.08
G	10.30		11.50	0.40		0.45
G1		5.45			0.21	
H	15.30		15.70	0.60		0.61
L	9.80	10	10.20	0.38	0.39	0.40
L2	22.80		23.20	0.89		0.91
L3	26.30		26.70	1.03		1.05
L4	43.20		44.40	1.70		1.74
L5	4.30		4.70	0.16		1.18
L6	24.30		24.70	0.95		0.97
L7	14.60		15	0.57		0.59
N	1.80		2.20	0.07		0.08
R	3.80		4.20	0.14		0.16
Dia	3.40		3.80	0.13		0.15

## 2.3 TO-247 LL package information

Figure 16. TO-247 LL package outline

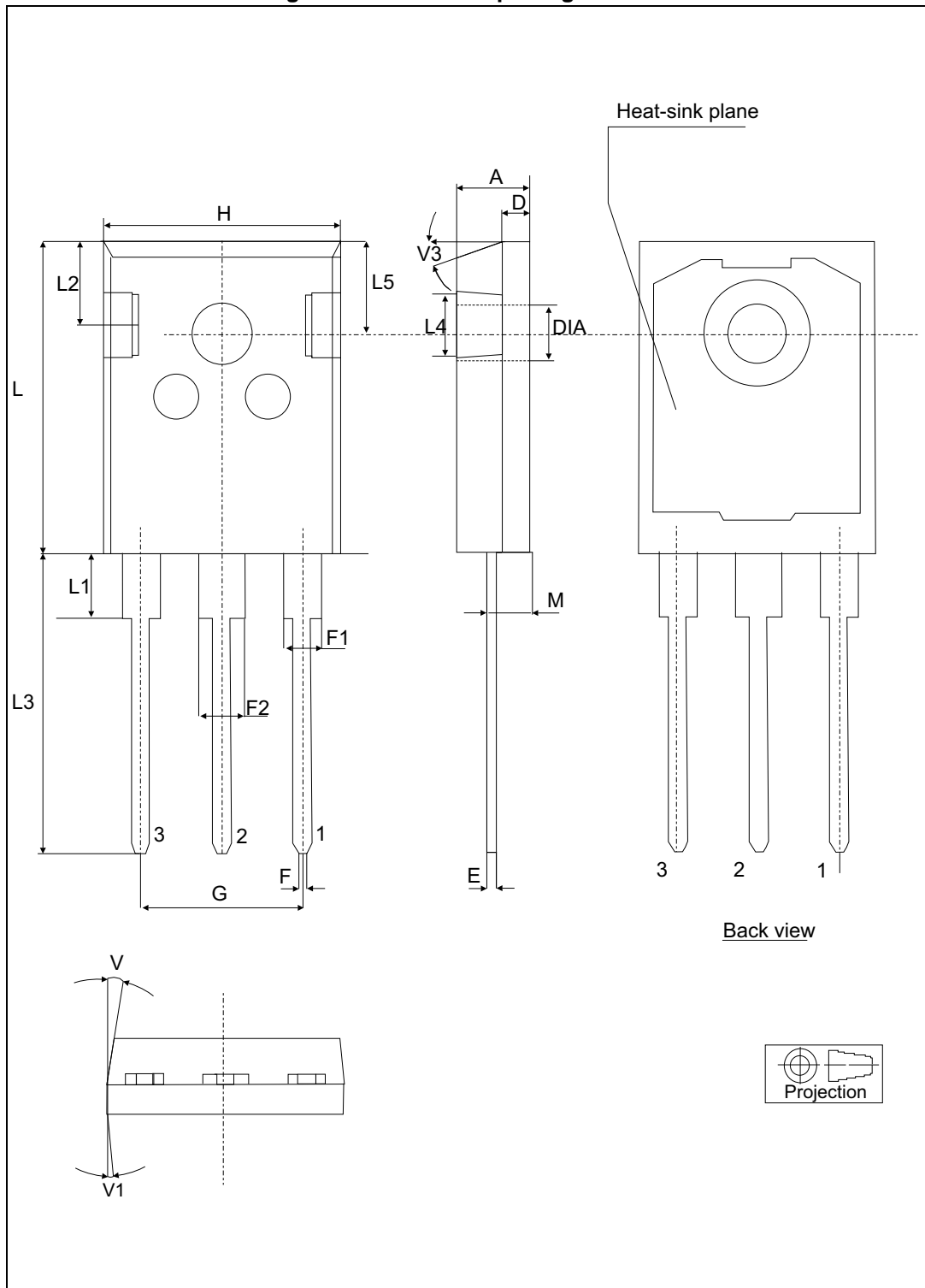

Table 8. TO-247 LL mechanical data

Ref.	Dimensions					
	Millimeters			Inches		
	Min.	Typ.	Max.	Min.	Typ	Max.
A	4.90		5.15	0.192		0.202
D	1.85		2.10	0.072		0.082
E	0.55		0.67	0.021		0.026
F	1.07		1.32	0.042		0.051
F1	1.90		2.38	0.074		0.093
F2	2.87		3.38	0.11		0.133
G	10.90 BSC			0.429 BSC		
H	15.77		16.02	0.62		0.63
L	20.82		21.07	0.81		0.82
L1	4.16		4.47	0.163		0.175
L2	5.49		5.74	0.216		0.225
L3	20.05		20.30	0.789		0.799
L4	3.68		3.93	0.144		0.154
L5	6.04		6.29	0.237		0.247
M	2.25		2.55	0.088		0.10
V		10°			10°	
V1		3°			3°	
V3		20°			20°	
∅	3.55		3.66	0.139		0.143

### 3 Ordering information

**Table 9. Ordering information**

Order code	Marking	Package	Weight	Base qty.	Delivery mode
STTH60AC06CP	STTH60AC06CP	TO3P-3L	5.26	30	Tube
STTH60AC06CPF	TH60AC06C	TO-3PF	5.6	30	Tube
STTH60AC06CW	STTH60AC06CW	TO-247 LL	4.36	30	Tube
STTH60AC06CWL	STTH60AC06CWL	TO-247 LL	4.36	30	Tube

### 4 Revision history

**Table 10. Document revision history**

Date	Revision	Changes
23-Jul-2013	1	First release.
20-Mar-2017	2	Added TO-247LL package information and reformatted to current standard.
29-Mar-2017	3	Updated <a href="#">Table 9</a> .

**STTH60AC06C**

---

**IMPORTANT NOTICE – PLEASE READ CAREFULLY**

STMicroelectronics NV and its subsidiaries ("ST") reserve the right to make changes, corrections, enhancements, modifications, and improvements to ST products and/or to this document at any time without notice. Purchasers should obtain the latest relevant information on ST products before placing orders. ST products are sold pursuant to ST's terms and conditions of sale in place at the time of order acknowledgement.

Purchasers are solely responsible for the choice, selection, and use of ST products and ST assumes no liability for application assistance or the design of Purchasers' products.

No license, express or implied, to any intellectual property right is granted by ST herein.

Resale of ST products with provisions different from the information set forth herein shall void any warranty granted by ST for such product.

ST and the ST logo are trademarks of ST. All other product or service names are the property of their respective owners.

Information in this document supersedes and replaces information previously supplied in any prior versions of this document.

© 2017 STMicroelectronics – All rights reserved



## OUR CERTIFICATE

DiGi provide top-quality products and perfect service for customer worldwide through standardization, technological innovation and continuous improvement. DiGi through third-party certification, we stricly control the quality of products and services. Welcome your RFQ to

Email: [Info@DiGi-Electronics.com](mailto:Info@DiGi-Electronics.com)



Tel: +00 852-30501935

RFQ Email: [Info@DiGi-Electronics.com](mailto:Info@DiGi-Electronics.com)

DiGi is a global authorized distributor of electronic components.