

TL062ACD Datasheet

www.digi-electronics.com



<https://www.DiGi-Electronics.com>

| | |
|------------------------------|------------------------------------|
| DiGi Electronics Part Number | TL062ACD-DG |
| Manufacturer | STMicroelectronics |
| Manufacturer Product Number | TL062ACD |
| Description | IC OPAMP JFET 2 CIRCUIT 8SO |
| Detailed Description | J-FET Amplifier 2 Circuit 8-SO |

This model TL062ACD is available at DiGi Electronics.

DiGi Electronics offers a global database of semiconductor and electronic component datasheets.

We welcome your inquiries regarding pricing, lead time, or other product-related questions.

 [Request a Quote](#)

 [Datasheet Search](#)



Tel: +00 852-30501935

RFQ Email: Info@DiGi-Electronics.com

DiGi is a global authorized distributor of electronic components.

Purchase and inquiry

Manufacturer Product Number:

TL062ACD

Series:

-

Amplifier Type:

J-FET

Output Type:

-

Gain Bandwidth Product:

1 MHz

Voltage - Input Offset:

3 mV

Current - Output / Channel:

20 mA

Voltage - Supply Span (Max):

36 V

Mounting Type:

Surface Mount

Supplier Device Package:

8-SO

Manufacturer:

STMicroelectronics

Product Status:

Obsolete

Number of Circuits:

2

Slew Rate:

3.5V/ μ s

Current - Input Bias:

30 nA

Current - Supply:

200 μ A (x2 Channels)

Voltage - Supply Span (Min):

6 V

Operating Temperature:

0°C ~ 70°C

Package / Case:

8-SOIC (0.154", 3.90mm Width)

Base Product Number:

TL062

Environmental & Export classification

RoHS Status:

ROHS3 Compliant

REACH Status:

REACH Unaffected

HTSUS:

8542.33.0001

Moisture Sensitivity Level (MSL):

1 (Unlimited)

ECCN:

EAR99



TL062, TL062A, TL062B

Low-power JFET dual operational amplifiers

Datasheet – production data

Features

- Very low power consumption: 200 μ A
- Wide common-mode (up to V_{CC}^+) and differential voltage ranges
- Low input bias and offset currents
- Output short-circuit protection
- High input impedance JFET input stage
- Internal frequency compensation
- Latch up free operation
- High slew rate: 3.5 V/ μ s

Description

The TL062, TL062A and TL062B devices are high-speed JFET input single operational amplifiers. Each of these JFET input operational amplifiers incorporates well matched, high-voltage JFET and bipolar transistors in a monolithic integrated circuit.

The devices feature high slew rates, low input bias and offset currents, and a low offset voltage temperature coefficient.



N
DIP8
(plastic package)



D
SO-8
(plastic micropackage)

Pin connections
(top view)

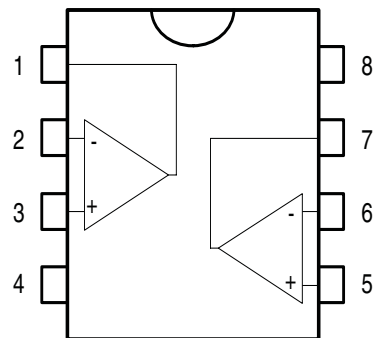

- 1 - Output 1
- 2 - Inverting input 1
- 3 - Non-inverting input 1
- 4 - V_{CC}^-
- 5 - Non-inverting input 2
- 6 - Inverting input 2
- 7 - Output 2
- 8 - V_{CC}^+

1 Schematic diagram

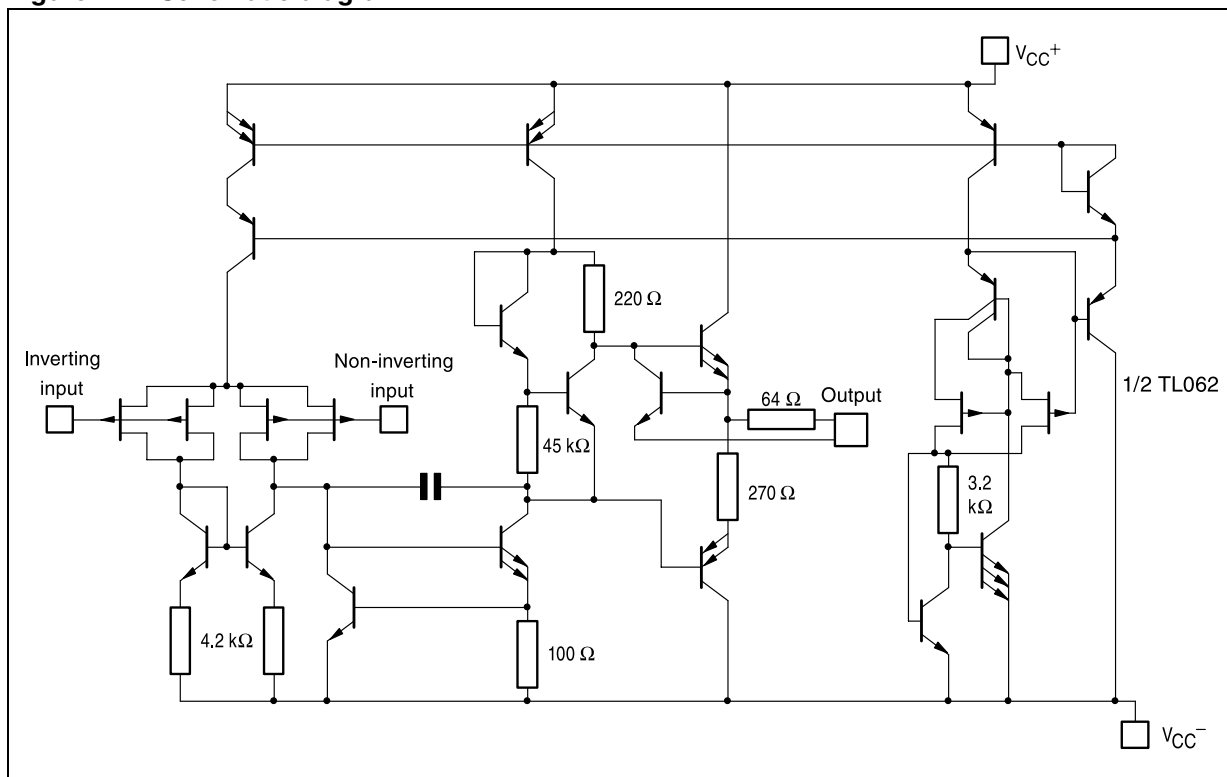
Figure 1. Schematic diagram

2 Absolute maximum ratings and operating conditions

Table 1. Absolute maximum ratings

| Symbol | Parameter | Value | Unit |
|------------|--|----------|------|
| V_{CC} | Supply voltage ⁽¹⁾ | ±18 | V |
| V_i | Input voltage ⁽²⁾ | ±15 | V |
| V_{id} | Differential input voltage ⁽³⁾ | ±30 | V |
| P_{tot} | Power dissipation | 680 | mW |
| | Output short-circuit duration ⁽⁴⁾ | Infinite | |
| T_{stg} | Storage temperature range | | °C |
| R_{thja} | Thermal resistance junction-to-ambient ^{(5), (6)} | | °C/W |
| | SO-8 | 125 | |
| R_{thjc} | DIP8 | 85 | |
| | Thermal resistance junction-to-case ^{(5), (6)} | | °C/W |
| ESD | SO-8 | 40 | |
| | DIP8 | 41 | |
| | HBM: human body model ⁽⁷⁾ | 900 | V |
| | MM: machine model ⁽⁸⁾ | 150 | V |
| | CDM: charged device model ⁽⁹⁾ | 1.5 | kV |

- All voltage values, except differential voltage, are with respect to the zero reference level (ground) of the supply voltages where the zero reference level is the midpoint between V_{CC}^+ and V_{CC}^- .
- The magnitude of the input voltage must never exceed the magnitude of the supply voltage or 15 volts, whichever is less.
- Differential voltages are the non-inverting input terminal with respect to the inverting input terminal.
- The output may be shorted to ground or to either supply. Temperature and/or supply voltages must be limited to ensure that the dissipation rating is not exceeded.
- Short-circuits can cause excessive heating and destructive dissipation.
- R_{th} are typical values.
- Human body model: 100 pF discharged through a 1.5 kΩ resistor between two pins of the device, done for all couples of pin combinations with other pins floating.
- Machine model: a 200 pF capacitor is charged to the specified voltage, then discharged directly between two pins of the device with no external series resistor (internal resistor < 5 Ω), done for all couples of pin combinations with other pins floating.
- Charged device model: all pins plus package are charged together to the specified voltage and then discharged directly to ground.

Table 2. Operating conditions

| Symbol | Parameter | TL062I, AI, BI | TL062C, AC, BC | Unit |
|------------|--------------------------------------|----------------|----------------|------|
| V_{CC} | Supply voltage range | 6 to 36 | | V |
| T_{oper} | Operating free air temperature range | -40 to +105 | 0 to +70 | °C |

3 Electrical characteristics

Table 3. $V_{CC} = \pm 15\text{ V}$, $T_{amb} = +25\text{ }^{\circ}\text{C}$ (unless otherwise specified)

| Symbol | Parameter | TL062I | | | TL062C | | | Unit |
|-----------------|--|------------|------------|-----------|------------|------------|-----------|--------------------------------|
| | | Min. | Typ. | Max. | Min. | Typ. | Max. | |
| V_{io} | Input offset voltage ($R_S = 50\ \Omega$) $T_{amb} = +25\text{ }^{\circ}\text{C}$ $T_{min} \leq T_{amb} \leq T_{max}$ | | 3 | 6 9 | | 3 | 15 20 | mV |
| DV_{io} | Temperature coefficient of input offset voltage ($R_S = 50\ \Omega$) | | 10 | | | 10 | | $\mu\text{V}/^{\circ}\text{C}$ |
| I_{io} | Input offset current ⁽¹⁾ $T_{amb} = +25\text{ }^{\circ}\text{C}$ $T_{min} \leq T_{amb} \leq T_{max}$ | | 5 | 100 10 | | 5 | 200 5 | pA nA |
| I_{ib} | Input bias current ⁽¹⁾ $T_{amb} = +25\text{ }^{\circ}\text{C}$ $T_{min} \leq T_{amb} \leq T_{max}$ | | 30 | 200 20 | | 30 | 400 10 | pA nA |
| V_{icm} | Input common mode voltage range | ± 11.5 | +15 -12 | | ± 11.5 | +15 -12 | | V |
| V_{opp} | Output voltage swing ($R_L = 10\ \text{k}\Omega$) $T_{amb} = +25\text{ }^{\circ}\text{C}$ $T_{min} \leq T_{amb} \leq T_{max}$ | 20 20 | 27 | | 20 20 | 27 | | V |
| A_{vd} | Large signal voltage gain $R_L = 10\ \text{k}\Omega$, $V_o = \pm 10\ \text{V}$, $T_{amb} = +25\text{ }^{\circ}\text{C}$ $T_{min} \leq T_{amb} \leq T_{max}$ | 4 4 | 6 | | 3 3 | 6 | | V/mV |
| GBP | Gain bandwidth product $T_{amb} = +25\text{ }^{\circ}\text{C}$, $R_L = 10\ \text{k}\Omega$, $C_L = 100\ \text{pF}$ | | 1 | | | 1 | | MHz |
| R_i | Input resistance | | 10^{12} | | | 10^{12} | | Ω |
| CMR | Common mode rejection ratio $R_S = 50\ \Omega$ | 80 | 86 | | 70 | 76 | | dB |
| SVR | Supply voltage rejection ratio $R_S = 50\ \Omega$ | 80 | 95 | | 70 | 95 | | dB |
| I_{CC} | Supply current, no load $T_{amb} = +25\text{ }^{\circ}\text{C}$, no load, no signal | | 200 | 250 | | 200 | 250 | μA |
| V_{o1}/V_{o2} | Channel separation $A_v = 100$, $T_{amb} = 25\text{ }^{\circ}\text{C}$ | | 120 | | | 120 | | dB |
| P_D | Total power consumption $T_{amb} = +25\text{ }^{\circ}\text{C}$, no load, no signal | | 6 | 7.5 | | 6 | 7.5 | mW |
| SR | Slew rate $V_i = 10\ \text{V}$, $R_L = 10\ \text{k}\Omega$, $C_L = 100\ \text{pF}$, $A_v = 1$ | 1.5 | 3.5 | | 1.5 | 3.5 | | V/ μs |

TL062, TL062A, TL062B

Electrical characteristics

Table 3. $V_{CC} = \pm 15\text{ V}$, $T_{amb} = +25\text{ }^\circ\text{C}$ (unless otherwise specified) (continued)

| Symbol | Parameter | TL062I | | | TL062C | | | Unit |
|----------|---|--------|------|------|--------|------|------|--------------------------------------|
| | | Min. | Typ. | Max. | Min. | Typ. | Max. | |
| t_r | Rise time $V_i = 20\text{ mV}$, $R_L = 10\text{ k}\Omega$ $C_L = 100\text{ pF}$, $A_v = 1$ | | 0.2 | | | 0.2 | | μs |
| K_{ov} | Overshoot factor (see Figure 15) $V_i = 20\text{ mV}$, $R_L = 10\text{ k}\Omega$, $C_L = 100\text{ pF}$, $A_v = 1$ | | 10 | | | 10 | | % |
| e_n | Equivalent input noise voltage $R_S = 100\text{ }\Omega$, $f = 1\text{ kHz}$ | | 42 | | | 42 | | $\frac{\text{nV}}{\sqrt{\text{Hz}}}$ |

1. The input bias currents of a FET-input operational amplifier are normal junction reverse currents, which are temperature sensitive. Pulse techniques must be used that will maintain the junction temperature as close to the ambient temperature as possible.

Table 4. $V_{CC} = \pm 15\text{ V}$, $T_{amb} = +25\text{ }^\circ\text{C}$ (unless otherwise specified)

| Symbol | Parameter | TL062AC, AI | | | TL062BC, BI | | | Unit |
|-----------|--|-------------|------------|----------|-------------|------------|--------|------------------------------|
| | | Min. | Typ. | Max. | Min. | Typ. | Max. | |
| V_{io} | Input offset voltage ($R_S = 50\text{ }\Omega$) $T_{amb} = +25\text{ }^\circ\text{C}$ $T_{min} \leq T_{amb} \leq T_{max}$ | | 3 | 3 7.5 | | 2 3 | 3 5 | mV |
| DV_{io} | Temperature coefficient of input offset voltage ($R_S = 50\text{ }\Omega$) | | 10 | | | 10 | | $\mu\text{V}/^\circ\text{C}$ |
| I_{io} | Input offset current ⁽¹⁾ $T_{amb} = +25\text{ }^\circ\text{C}$ $T_{min} \leq T_{amb} \leq T_{max}$ | | 5 | 100 3 | | 5 100 | 3 3 | pA nA |
| I_{ib} | Input bias current ⁽¹⁾ $T_{amb} = +25\text{ }^\circ\text{C}$ $T_{min} \leq T_{amb} \leq T_{max}$ | | 30 | 200 7 | | 30 200 | 7 7 | nA |
| V_{icm} | Input common mode voltage range | ± 11.5 | +15 -12 | | ± 11.5 | +15 -12 | | |
| V_{opp} | Output voltage swing ($R_L = 10\text{ k}\Omega$) $T_{amb} = +25\text{ }^\circ\text{C}$ $T_{min} \leq T_{amb} \leq T_{max}$ | 20 20 | 27 | | 20 20 | 27 | | V |
| A_{vd} | Large signal voltage gain $R_L = 10\text{ k}\Omega$, $V_o = \pm 10\text{ V}$, $T_{amb} = +25\text{ }^\circ\text{C}$ $T_{min} \leq T_{amb} \leq T_{max}$ | 4 4 | 6 | | 4 4 | 6 | | V/mV |
| GBP | Gain bandwidth product $T_{amb} = +25\text{ }^\circ\text{C}$, $R_L = 10\text{ k}\Omega$, $C_L = 100\text{ pF}$ | | 1 | | | 1 | | MHz |
| R_i | Input resistance | | 10^{12} | | | 10^{12} | | Ω |
| CMR | Common mode rejection ratio $R_S = 50\text{ }\Omega$ | 80 | 86 | | 80 | 86 | | dB |
| SVR | Supply voltage rejection ratio $R_S = 50\text{ }\Omega$ | 80 | 95 | | 80 | 95 | | dB |

Electrical characteristics

TL062, TL062A, TL062B

Table 4. $V_{CC} = \pm 15\text{ V}$, $T_{amb} = +25\text{ °C}$ (unless otherwise specified) (continued)

| Symbol | Parameter | TL062AC, AI | | | TL062BC, BI | | | Unit |
|-----------------|---|-------------|------|------|-------------|------|------|--------------------------------------|
| | | Min. | Typ. | Max. | Min. | Typ. | Max. | |
| I_{CC} | Supply current, no load $T_{amb} = +25\text{ °C}$, no load, no signal | | 200 | 250 | | 200 | 250 | μA |
| V_{o1}/V_{o2} | Channel separation $A_v = 100$, $T_{amb} = +25\text{ °C}$ | | 120 | | | 120 | | |
| P_D | Total power consumption $T_{amb} = +25\text{ °C}$, no load, no signal | | 6 | 7.5 | | 6 | 7.5 | mW |
| SR | Slew rate $V_i = 10\text{ V}$, $R_L = 10\text{ k}\Omega$, $C_L = 100\text{ pF}$, $A_v = 1$ | 1.5 | 3.5 | | 1.5 | 3.5 | | V/ μs |
| t_r | Rise time $V_i = 20\text{ mV}$, $R_L = 10\text{ k}\Omega$, $C_L = 100\text{ pF}$, $A_v = 1$ | | 0.2 | | | 0.2 | | μs |
| K_{ov} | Overshoot factor (see Figure 15) $V_i = 20\text{ mV}$, $R_L = 10\text{ k}\Omega$, $C_L = 100\text{ pF}$, $A_v = 1$ | | 10 | | | 10 | | % |
| e_n | Equivalent input noise voltage $R_S = 100\ \Omega$, $f = 1\text{ kHz}$ | | 42 | | | 42 | | $\frac{\text{nV}}{\sqrt{\text{Hz}}}$ |

- The input bias currents of a FET-input operational amplifier are normal junction reverse currents, which are temperature sensitive. Pulse techniques must be used that will maintain the junction temperature as close to the ambient temperature as possible.

Figure 2. Maximum peak-to-peak output voltage versus supply voltage

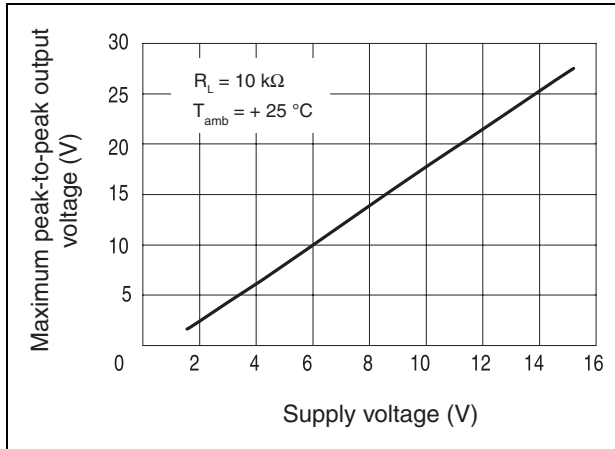

Figure 3. Maximum peak-to-peak output voltage versus free air temperature

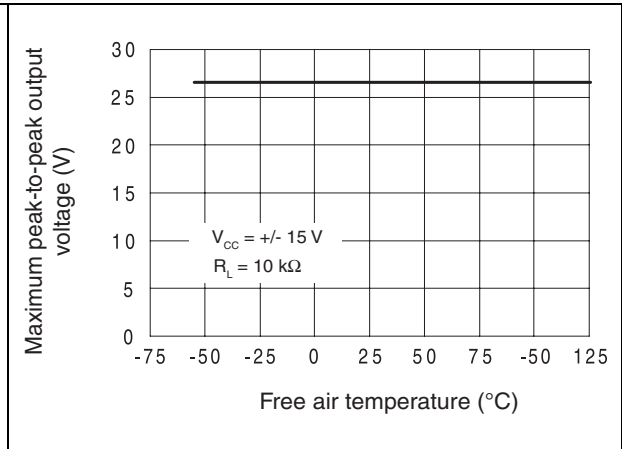

Figure 4. Maximum peak-to-peak output voltage versus load resistance

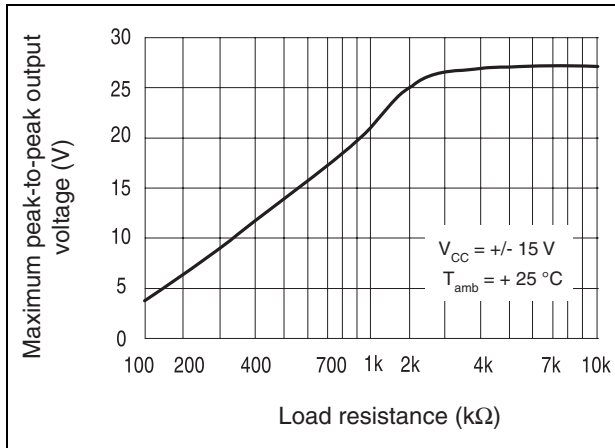

Figure 5. Maximum peak-to-peak output voltage versus frequency

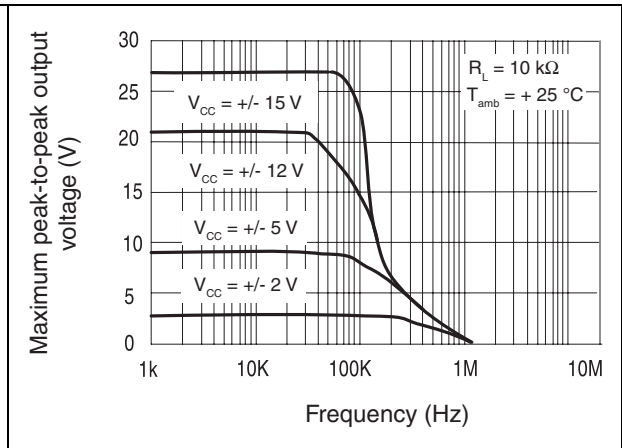

Figure 6. Differential voltage amplification versus free air temperature

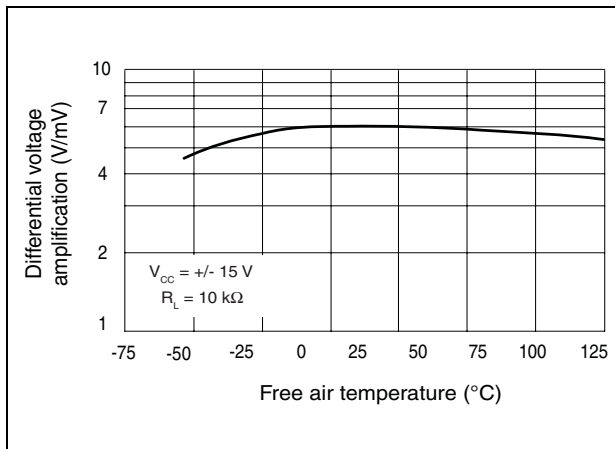
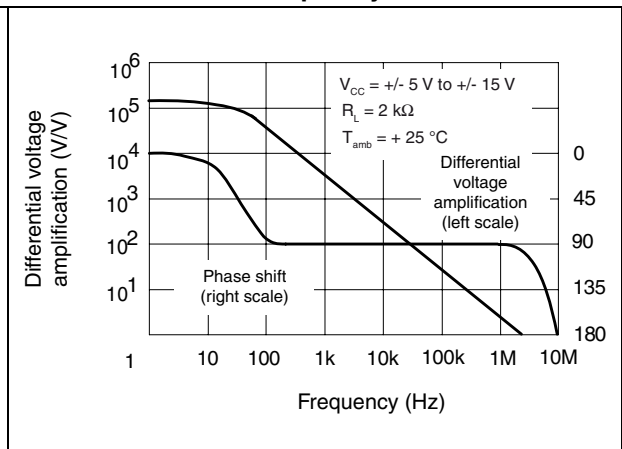

Figure 7. Large signal differential voltage amplification and phase shift versus frequency



Electrical characteristics

TL062, TL062A, TL062B

Figure 8. Supply current per amplifier versus supply voltage

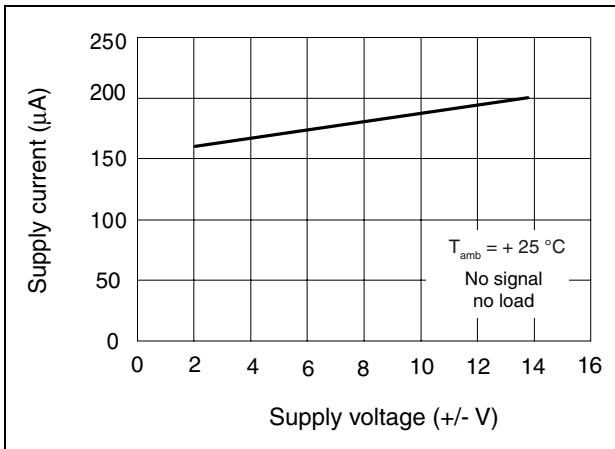

Figure 9. Supply current per amplifier versus free air temperature

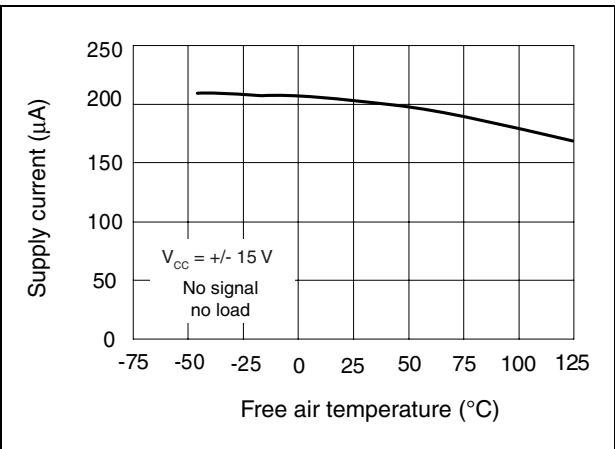

Figure 10. Total power dissipated versus free air temperature

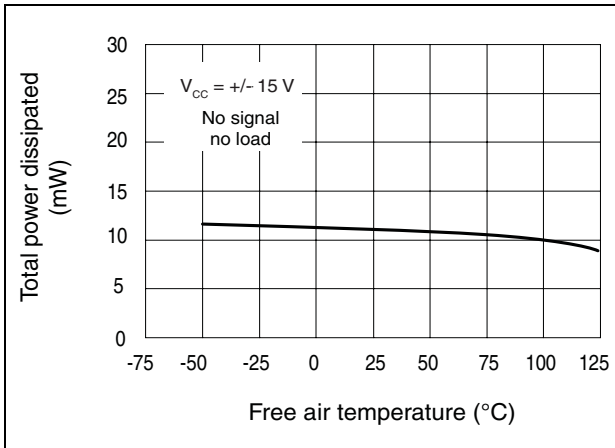

Figure 11. Common-mode rejection ratio versus free air temperature

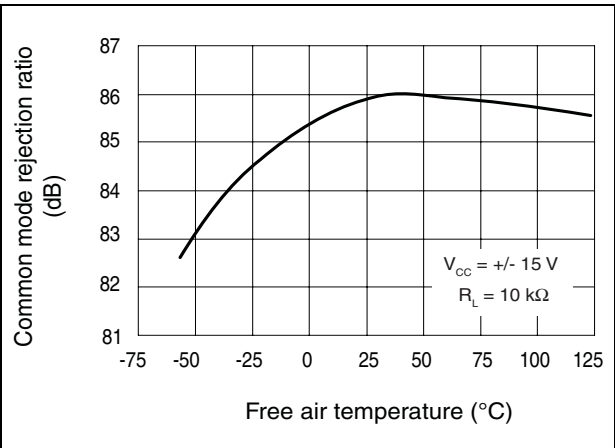

Figure 12. Normalized unity gain bandwidth, slew rate and phase shift versus temperature

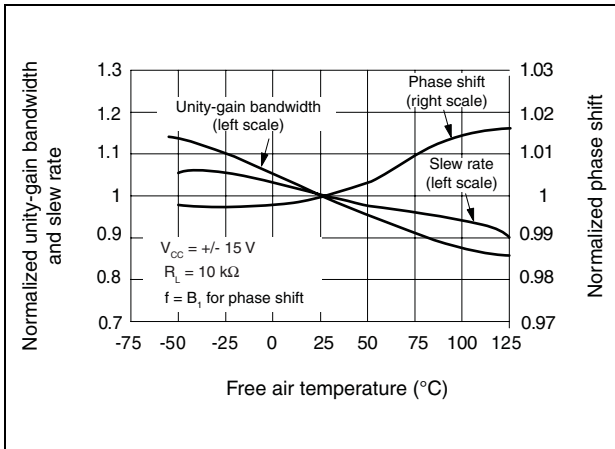

Figure 13. Input bias current versus free air temperature

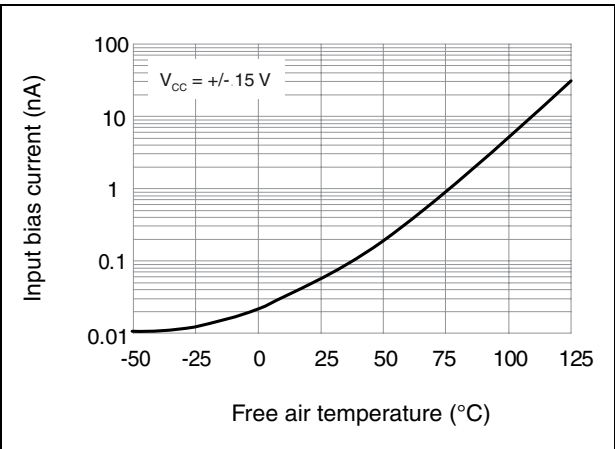

Figure 14. Voltage follower large signal pulse response

Figure 15. Output voltage versus elapsed time

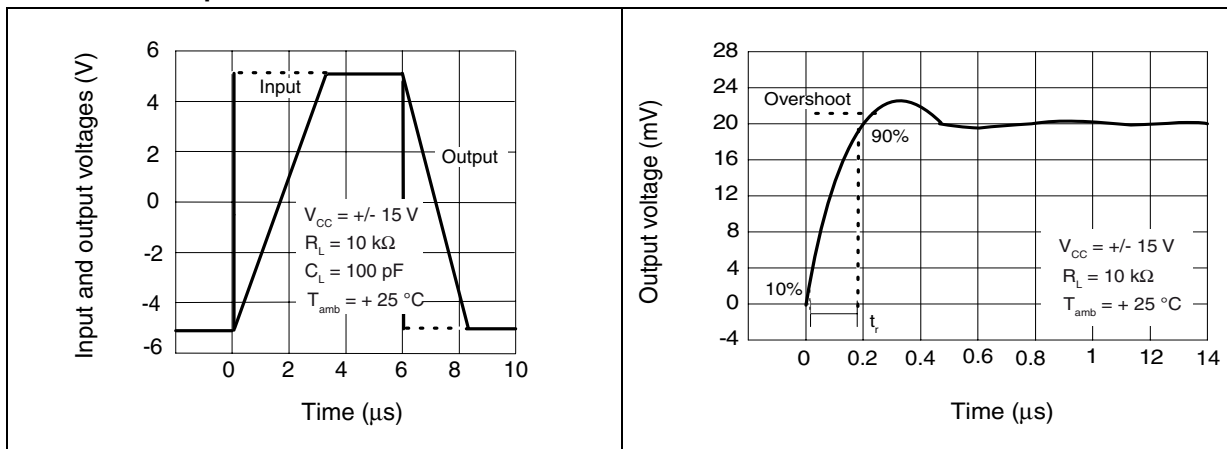
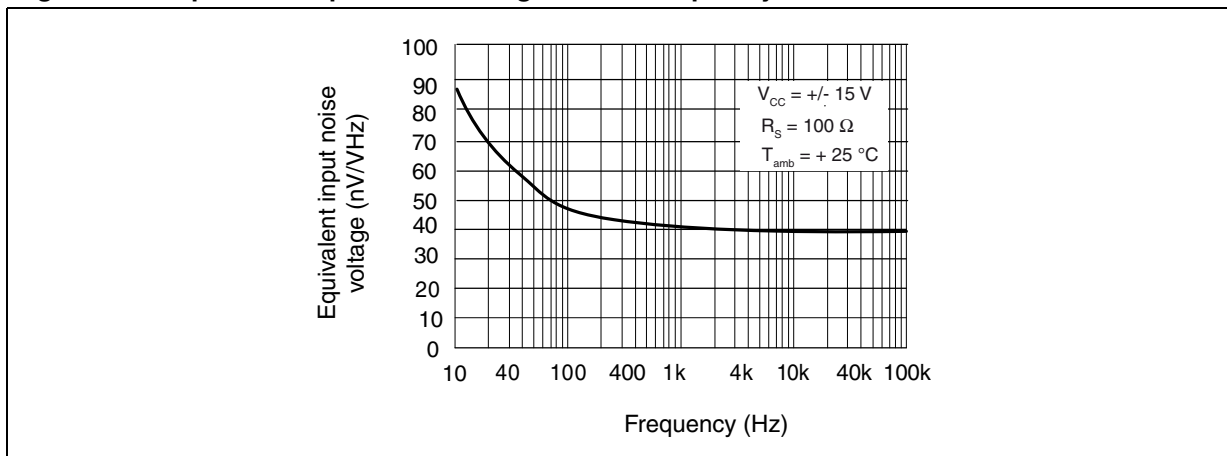

Figure 16. Equivalent input noise voltage versus frequency



Parameter measurement information

Figure 17. Voltage follower

Figure 18. Gain of 10 inverting amplifier

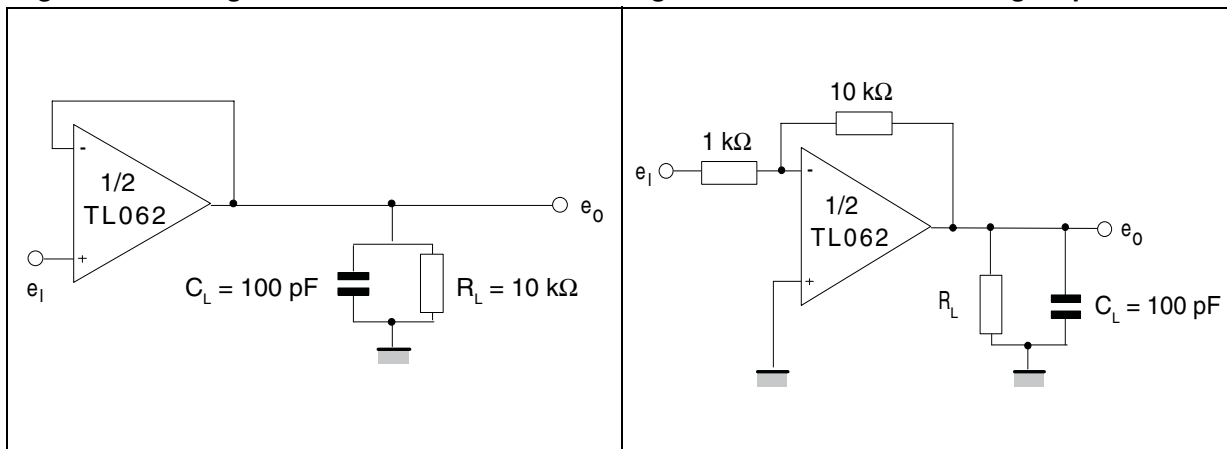

4 Typical applications

Figure 19. 100 kHz quadrature oscillator

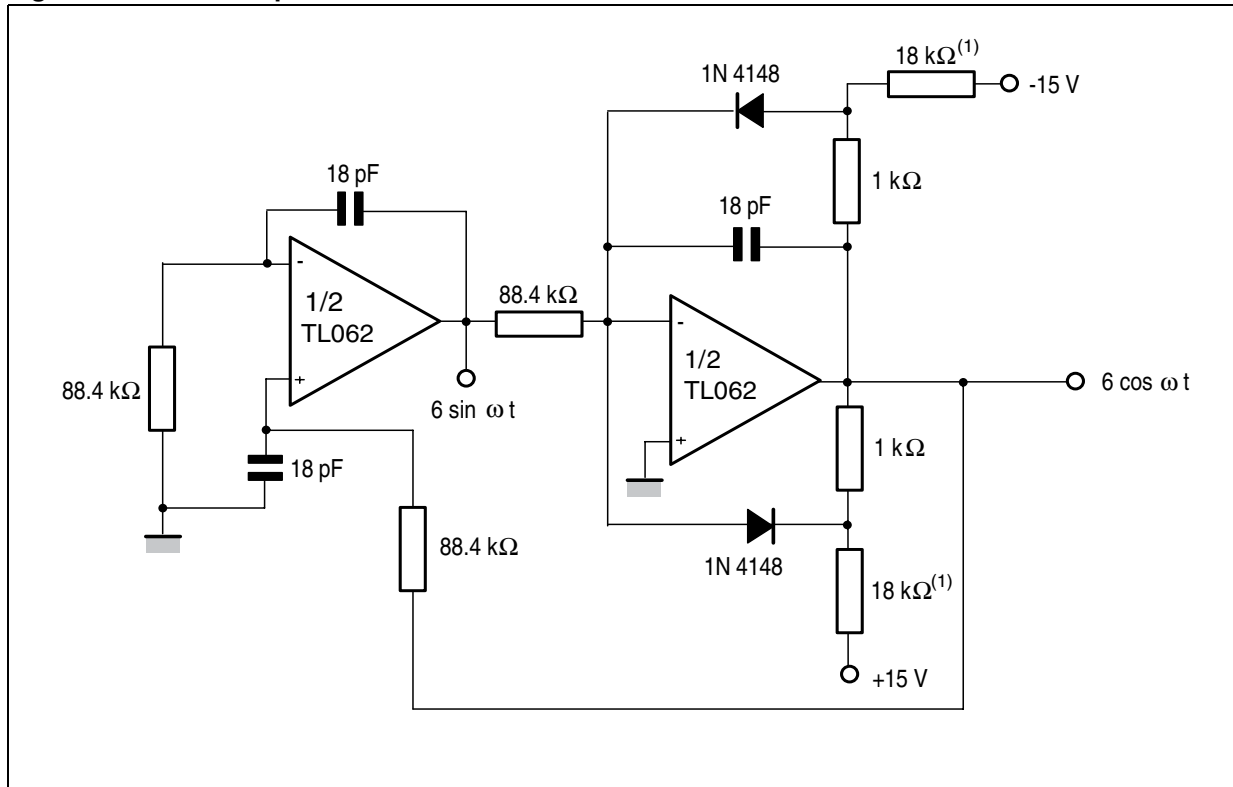

1. These resistor values may be adjusted for a symmetrical output.

5 Package information

In order to meet environmental requirements, ST offers these devices in different grades of ECOPACK[®] packages, depending on their level of environmental compliance. ECOPACK specifications, grade definitions and product status are available at: www.st.com. ECOPACK is an ST trademark.

5.1 DIP8 package information

Figure 20. DIP8 package outline

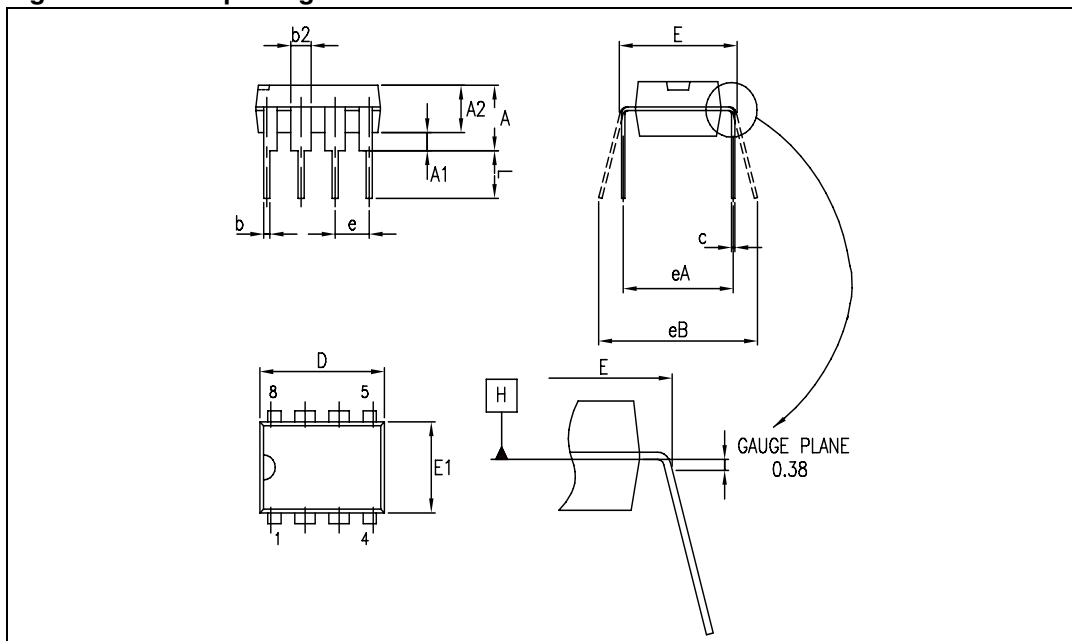

Table 5. DIP8 package mechanical data

| Symbol | Dimensions | | | | | |
|--------|-------------|------|-------|--------|-------|-------|
| | Millimeters | | | Inches | | |
| | Min. | Typ. | Max. | Min. | Typ. | Max. |
| A | | | 5.33 | | | 0.210 |
| A1 | 0.38 | | | 0.015 | | |
| A2 | 2.92 | 3.30 | 4.95 | 0.115 | 0.130 | 0.195 |
| b | 0.36 | 0.46 | 0.56 | 0.014 | 0.018 | 0.022 |
| b2 | 1.14 | 1.52 | 1.78 | 0.045 | 0.060 | 0.070 |
| c | 0.20 | 0.25 | 0.36 | 0.008 | 0.010 | 0.014 |
| D | 9.02 | 9.27 | 10.16 | 0.355 | 0.365 | 0.400 |
| E | 7.62 | 7.87 | 8.26 | 0.300 | 0.310 | 0.325 |
| E1 | 6.10 | 6.35 | 7.11 | 0.240 | 0.250 | 0.280 |
| e | | 2.54 | | | 0.100 | |
| eA | | 7.62 | | | 0.300 | |
| eB | | | 10.92 | | | 0.430 |
| L | 2.92 | 3.30 | 3.81 | 0.115 | 0.130 | 0.150 |

Note: Dimensions "D" and "E1" do not include mold flash, protrusions or gate burrs. Mold flash, protrusions or gate burrs shall not exceed 0.25 mm in total (both sides). Datum plane "H" coincides with the bottom of the lead, where the lead exits the body.

5.2 SO-8 package information

Figure 21. SO-8 package outline

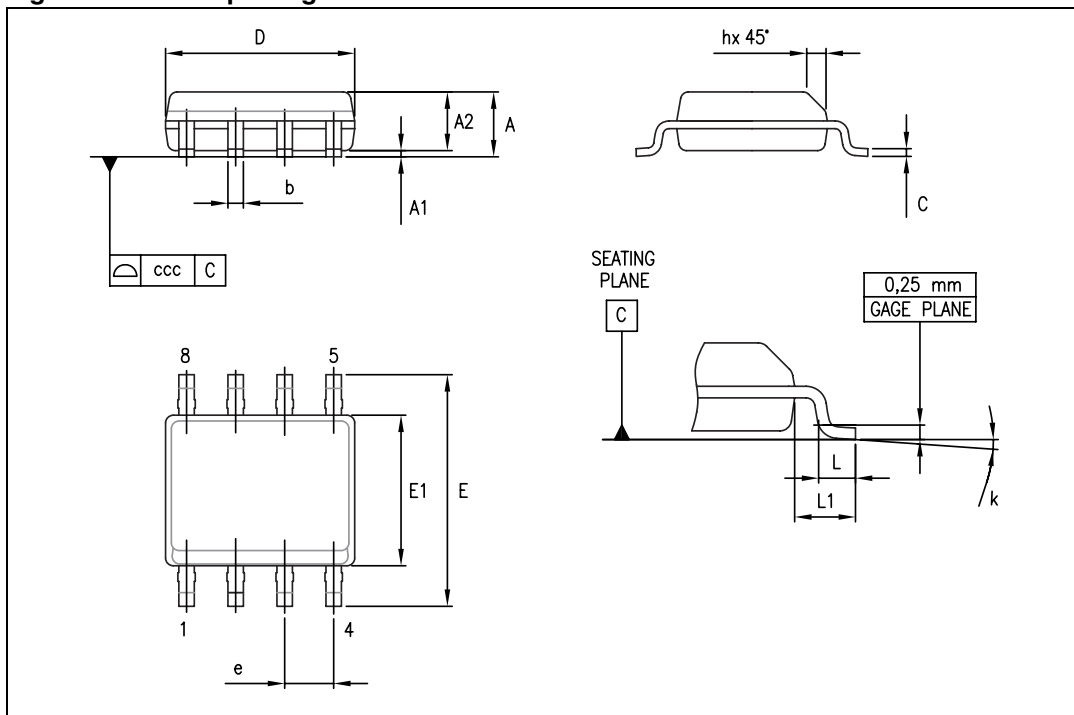

Table 6. SO-8 package mechanical data

| Symbol | Dimensions | | | | | |
|--------|-------------|------|------|--------|-------|-------|
| | Millimeters | | | Inches | | |
| | Min. | Typ. | Max. | Min. | Typ. | Max. |
| A | | | 1.75 | | | 0.069 |
| A1 | 0.10 | | 0.25 | 0.004 | | 0.010 |
| A2 | 1.25 | | | 0.049 | | |
| b | 0.28 | | 0.48 | 0.011 | | 0.019 |
| c | 0.17 | | 0.23 | 0.007 | | 0.010 |
| D | 4.80 | 4.90 | 5.00 | 0.189 | 0.193 | 0.197 |
| E | 5.80 | 6.00 | 6.20 | 0.228 | 0.236 | 0.244 |
| E1 | 3.80 | 3.90 | 4.00 | 0.150 | 0.154 | 0.157 |
| e | | 1.27 | | | 0.050 | |
| h | 0.25 | | 0.50 | 0.010 | | 0.020 |
| L | 0.40 | | 1.27 | 0.016 | | 0.050 |
| L1 | | 1.04 | | | 0.040 | |
| k | 0 | | 8° | 1° | | 8° |
| ccc | | | 0.10 | | | 0.004 |

6 Ordering information

Table 7. Order codes

| Part number | Temperature range | Package | Packaging | Marking |
|---|-------------------|---------|--------------------------|---------------------------------|
| TL062IN TL062AIN TL062BIN | -40 °C, +105 °C | DIP8 | Tube | TL062IN TL062AIN TL062BIN |
| TL062ID/IDT TL062AID/AIDT TL062BID/BIDT | | SO-8 | Tube or tape and reel | 062I 062AI 062BI |
| TL062CN TL062ACN TL062BCN | 0 °C, +70 °C | DIP8 | Tube | TL062CN TL062ACN TL062BCN |
| TL062CD/CDT TL062ACD/ACDT TL062BCD/BCDT | | SO-8 | Tube or tape and reel | 062C 062AC 062BC |

7 Revision history

Table 8. Document revision history

| Date | Revision | Changes |
|-------------|----------|---|
| 28-Mar-2001 | 1 | Initial release. |
| 27-Jul-2007 | 2 | Added values for R_{thja} and R_{thjc} in Table 1: Absolute maximum ratings . Added Table 2: Operating conditions . Updated format. |
| 15-Mar-2010 | 3 | Updated document format. Added TL062A and TL062B in title on cover page. Updated package information in Chapter 5 . |
| 21-Sep-2012 | 4 | Removed TL062M, AM, BM /TL062I, AI, BI / TL062C, AC, BC part numbers and temperature ranges from Table 1 . and TL062M, AM, BM from Table 2 . Removed TL062M, updated min. "Input common mode voltage range" for TL062C device in Table 3 . Removed TL062AM and TL062BM devices, updated max. "Input offset voltage - T_{amb} " for TL062AC, AI devices in Table 4 . Removed TL062MN, TL062AMN, TL062BMN, TL062MD/MDT, TL062AMD/AMDT, TL062BMD/BMDT part numbers from Table 7 . Minor corrections throughout document. |

TL062, TL062A, TL062B

Please Read Carefully:

Information in this document is provided solely in connection with ST products. STMicroelectronics NV and its subsidiaries ("ST") reserve the right to make changes, corrections, modifications or improvements, to this document, and the products and services described herein at any time, without notice.

All ST products are sold pursuant to ST's terms and conditions of sale.

Purchasers are solely responsible for the choice, selection and use of the ST products and services described herein, and ST assumes no liability whatsoever relating to the choice, selection or use of the ST products and services described herein.

No license, express or implied, by estoppel or otherwise, to any intellectual property rights is granted under this document. If any part of this document refers to any third party products or services it shall not be deemed a license grant by ST for the use of such third party products or services, or any intellectual property contained therein or considered as a warranty covering the use in any manner whatsoever of such third party products or services or any intellectual property contained therein.

UNLESS OTHERWISE SET FORTH IN ST'S TERMS AND CONDITIONS OF SALE ST DISCLAIMS ANY EXPRESS OR IMPLIED WARRANTY WITH RESPECT TO THE USE AND/OR SALE OF ST PRODUCTS INCLUDING WITHOUT LIMITATION IMPLIED WARRANTIES OF MERCHANTABILITY, FITNESS FOR A PARTICULAR PURPOSE (AND THEIR EQUIVALENTS UNDER THE LAWS OF ANY JURISDICTION), OR INFRINGEMENT OF ANY PATENT, COPYRIGHT OR OTHER INTELLECTUAL PROPERTY RIGHT.

UNLESS EXPRESSLY APPROVED IN WRITING BY TWO AUTHORIZED ST REPRESENTATIVES, ST PRODUCTS ARE NOT RECOMMENDED, AUTHORIZED OR WARRANTED FOR USE IN MILITARY, AIR CRAFT, SPACE, LIFE SAVING, OR LIFE SUSTAINING APPLICATIONS, NOR IN PRODUCTS OR SYSTEMS WHERE FAILURE OR MALFUNCTION MAY RESULT IN PERSONAL INJURY, DEATH, OR SEVERE PROPERTY OR ENVIRONMENTAL DAMAGE. ST PRODUCTS WHICH ARE NOT SPECIFIED AS "AUTOMOTIVE GRADE" MAY ONLY BE USED IN AUTOMOTIVE APPLICATIONS AT USER'S OWN RISK.

Resale of ST products with provisions different from the statements and/or technical features set forth in this document shall immediately void any warranty granted by ST for the ST product or service described herein and shall not create or extend in any manner whatsoever, any liability of ST.

ST and the ST logo are trademarks or registered trademarks of ST in various countries.

Information in this document supersedes and replaces all information previously supplied.

The ST logo is a registered trademark of STMicroelectronics. All other names are the property of their respective owners.

© 2012 STMicroelectronics - All rights reserved

STMicroelectronics group of companies

Australia - Belgium - Brazil - Canada - China - Czech Republic - Finland - France - Germany - Hong Kong - India - Israel - Italy - Japan - Malaysia - Malta - Morocco - Philippines - Singapore - Spain - Sweden - Switzerland - United Kingdom - United States of America

www.st.com



OUR CERTIFICATE

DiGi provide top-quality products and perfect service for customer worldwide through standardization, technological innovation and continuous improvement. DiGi through third-party certification, we stricly control the quality of products and services. Welcome your RFQ to

Email: Info@DiGi-Electronics.com



Tel: +00 852-30501935

RFQ Email: Info@DiGi-Electronics.com

DiGi is a global authorized distributor of electronic components.