

TS374IDT Datasheet

www.digi-electronics.com

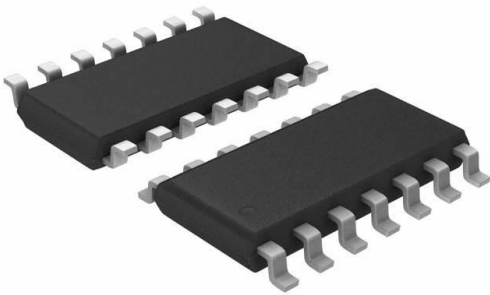

<https://www.DiGi-Electronics.com>

DiGi Electronics Part Number	TS374IDT-DG
Manufacturer	STMicroelectronics
Manufacturer Product Number	TS374IDT
Description	IC COMPARATOR 4 DIFF 14SO
Detailed Description	Comparator Differential CMOS, MOS, Open-Drain, T TL 14-SO

This model TS374IDT is available at DiGi Electronics.

DiGi Electronics offers a global database of semiconductor and electronic component datasheets.

We welcome your inquiries regarding pricing, lead time, or other product-related questions.

 [Request a Quote](#)

 [Datasheet Search](#)



Tel: +00 852-30501935

RFQ Email: Info@DiGi-Electronics.com

DiGi is a global authorized distributor of electronic components.

Purchase and inquiry

Manufacturer Product Number:

TS374IDT

Series:

-

Type:

Differential

Output Type:

CMOS, MOS, Open-Drain, TTL

Voltage - Input Offset (Max):

10mV @ 5V

Current - Output (Typ):

20mA

CMRR, PSRR (Typ):

-

Hysteresis:

-

Package / Case:

14-SOIC (0.154", 3.90mm Width)

Supplier Device Package:

14-SO

Manufacturer:

STMicroelectronics

Product Status:

Active

Number of Elements:

4

Voltage - Supply, Single/Dual (\pm):

3V ~ 16V, \pm 1.5V ~ 8V

Current - Input Bias (Max):

1pA @ 5V

Current - Quiescent (Max):

250 μ A

Propagation Delay (Max):

-

Operating Temperature:

-40°C ~ 125°C

Mounting Type:

Surface Mount

Base Product Number:

TS374

Environmental & Export classification

RoHS Status:

ROHS3 Compliant

REACH Status:

REACH Unaffected

HTSUS:

8542.39.0001

Moisture Sensitivity Level (MSL):

1 (Unlimited)

ECCN:

EAR99



TS374

LOW POWER QUAD CMOS VOLTAGE COMPARATOR

- WIDE SINGLE SUPPLY RANGE OR DUAL SUPPLIES **3V TO 16V** OR $\pm 1.5V$ TO $\pm 8V$
- VERY LOW SUPPLY CURRENT:
0.1mA/COMP INDEPENDENT OF SUPPLY VOLTAGE
- EXTREMELY LOW INPUT BIAS CURRENT :
1pA typ
- EXTREMELY LOW INPUT OFFSET CURRENTS : **1pA typ**
- LOW INPUT OFFSET VOLTAGE
- INPUT COMMON-MODE VOLTAGE RANGE INCLUDES GND
- LOW OUTPUT SATURATION VOLTAGE
150mV TYP
- OUTPUT COMPATIBLE WITH TTL, MOS AND CMOS
- HIGH INPUT IMPEDANCE : $10^{12}\Omega$ typ
- FAST RESPONSE TIME : 200ns TYP FOR TTL LEVEL INPUT STEP

DESCRIPTION

These devices consist of four independent precision voltage comparators, designed to operate with single or dual supplies.

These differential comparators use the STMicroelectronics silicon lin MOS process giving them an excellent consumption-speed ratio.

These devices are ideally suited for low consumption applications.

ORDER CODE

Part Number	Temperature Range	Package	
		N	D
TS374C	0°C, +70°C	•	•
TS374I	-40°C, +125°C	•	•
TS374M	-55°C, +125°C	•	•

N = Dual in Line Package (DIP)

D = Small Outline Package (SO) - also available in Tape & Reel (DT)

February 2002

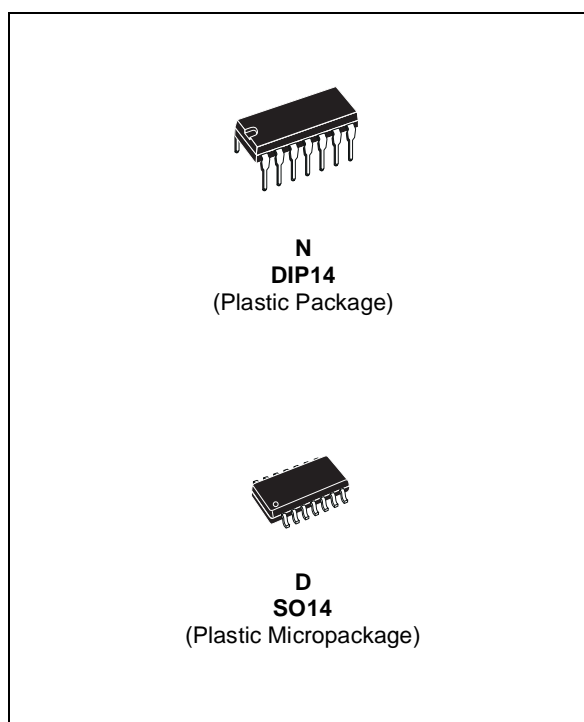

PIN CONNECTIONS (top view)

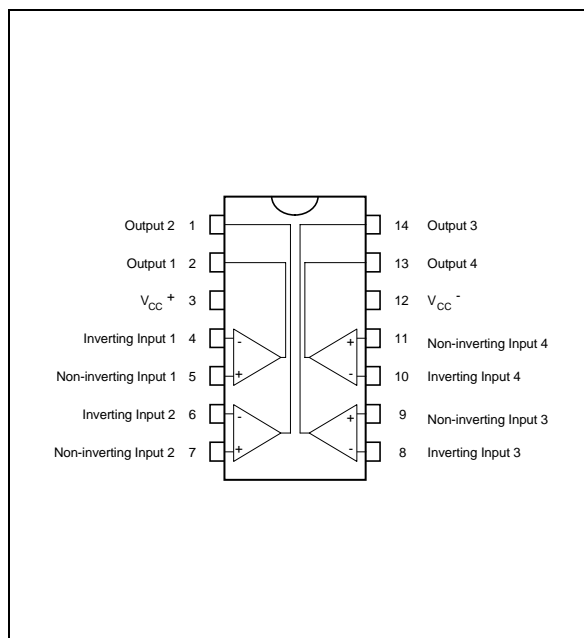

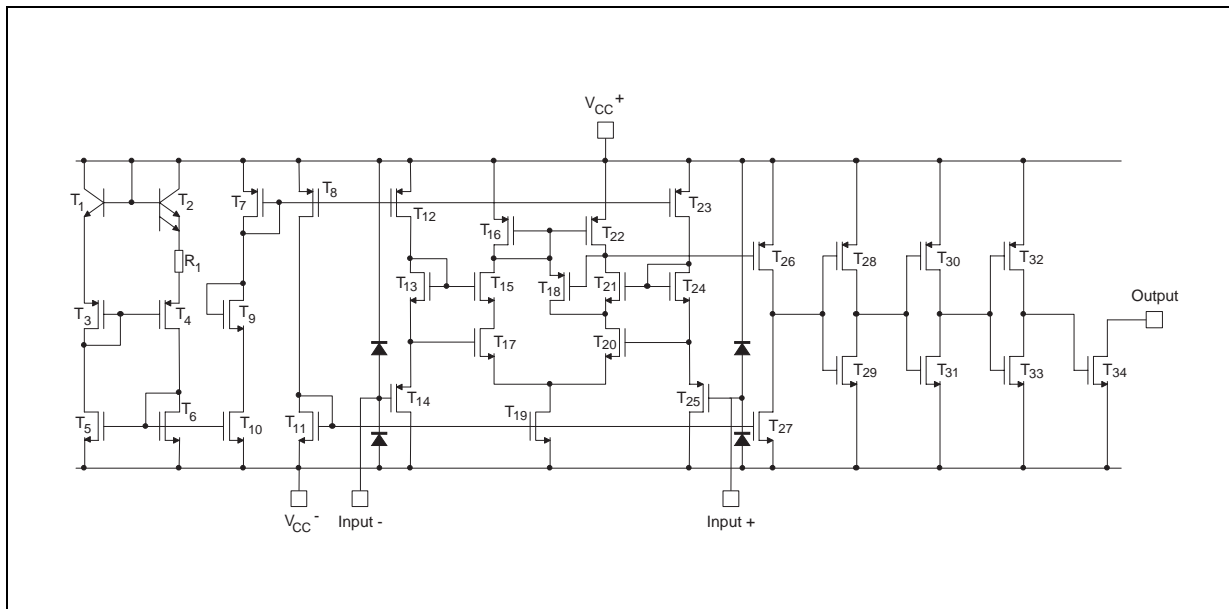
TS374**SCHEMATIC DIAGRAM** (for 1/4 TS374)**ABSOLUTE MAXIMUM RATINGS**

Symbol	Parameter	Value	Unit
V_{CC}^+	Supply Voltage ¹⁾	18	V
V_{id}	Differential Input Voltage ²⁾	± 18	V
V_i	Input Voltage ³⁾	18	V
V_o	Output Voltage	18	V
I_o	Output Current	20	mA
I_F	Forward Current in ESD Protection Diodes on Input ⁴⁾	50	mA
	Duration of Output-Circuit to GND ⁵⁾	Infinite	
P_d	Power Dissipation ⁶⁾	DIP14 830	mW
T_{stg}	Storage Temperature Range	-65 to +150	$^{\circ}\text{C}$
T_j	Junction Temperature	+150	$^{\circ}\text{C}$

- All voltage values, except differential voltage, are with respect to network ground terminal.
- Differential voltages are the non-inverting input terminal with respect to the inverting input terminal.
- The magnitude of the input and the output voltages must never exceed the magnitude of the positive supply voltage.
- Guaranteed by design.
- Short circuit from outputs to V_{CC}^+ can cause excessive heating and eventual destruction.
- P_d is calculated with $T_{amb} = +25^{\circ}\text{C}$, $T_j = +150^{\circ}\text{C}$ and $R_{thja} = 80^{\circ}\text{C/W}$ for DIP14 package
 $= 150^{\circ}\text{C/W}$ for SO14 package

OPERATING CONDITIONS

Symbol	Parameter	Value	Unit
V_{CC}^+	Supply Voltage	3 to 16	V
V_{icm}	Common Mode Input Voltage Range	0 to $V_{CC}^+ - 1.5$	V
T_{oper}	Operating Free-Air Temperature range	TS374C TS374I TS374M	$^{\circ}\text{C}$
		0 to +70 -40 to +125 -55 to +125	

ELECTRICAL CHARACTERISTICS $V_{CC}^+ = 5V$, $V_{CC}^- = 0V$, $T_{amb} = 25^\circ C$ (unless otherwise specified)

Symbol	Parameter	Min.	Typ.	Max.	Unit
V_{io}	Input Offset Voltage ($V_{ic} = V_{icm \text{ min.}}$) ¹⁾ $T_{amb} = 25^\circ C$ $T_{min.} \leq T_{amb} \leq T_{max.}$		2	10 12	mV
I_{io}	Input Offset Current ²⁾ $T_{amb} = 25^\circ C$ $T_{min.} \leq T_{amb} \leq T_{max.}$		1	100 200	pA
I_{ib}	Input Offset Current - see note 2 $T_{amb} = 25^\circ C$ $T_{min.} \leq T_{amb} \leq T_{max.}$		1	150 300	pA
V_{icm}	Input Common Mode Voltage Range $T_{amb} = 25^\circ C$ $T_{min.} \leq T_{amb} \leq T_{max.}$	0 0 0		$V_{CC}^+ - 2$ $V_{CC}^+ - 2.25$ $V_{CC}^+ - 2.5$	V
I_{OH}	High Level Output Current ($V_{id} = 1V$) $T_{amb} = 25^\circ C$ $T_{min.} \leq T_{amb} \leq T_{max.}$		0.1	1	nA μA
V_{OL}	Low Level Output Voltage ($V_{id} = -1$, $I_{OL} = 4mA$) $T_{amb} = 25^\circ C$ $T_{min.} \leq T_{amb} \leq T_{max.}$		100	400 700	mV
I_{OL}	Low Level Output Current ($V_{id} = -1$, $V_{OL} = 1.5V$)	6	45		mA
I_{CC}	Supply Current (each comparator) ($V_{id} = 1V$, no load)		150	250	μA

1. The specified offset voltage is the maximum value required to drive the output down to 400mV or to 4V with $R_L = 100k\Omega$ to V_{CC}^+

2. Maximum values including unavoidable inaccuracies of the industrial test.

SWITCHING CHARACTERISTICS ($V_{CC}^+ = 5V$, $T_{amb} = 25^\circ C$)

Symbol	Parameter	Min.	Typ.	Max.	Unit
t_{re}	Response Time ($R_L = 5.1k\Omega$ connected to 5V, $C_L = 15pF$) ¹⁾ 100mV input step with 5mV overdrive TTL level input step		600 200		ns

1. The response time which is specified is the interval between the input signal and the instant when the output signal crosses 1.4V.

TS374

PACKAGE MECHANICAL DATA
14 PINS - PLASTIC DIP

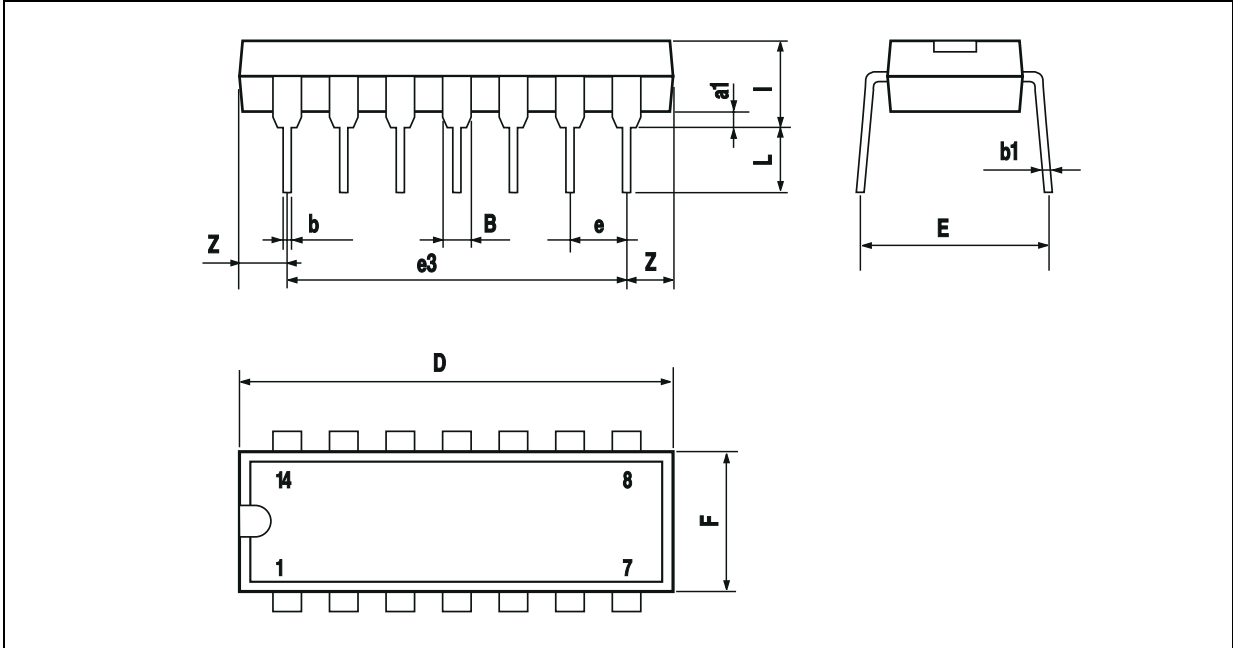

Dimensions	Millimeters			Inches		
	Min.	Typ.	Max.	Min.	Typ.	Max.
a1	0.51			0.020		
B	1.39		1.65	0.055		0.065
b		0.5			0.020	
b1		0.25			0.010	
D			20			0.787
E		8.5			0.335	
e		2.54			0.100	
e3		15.24			0.600	
F			7.1			0.280
i			5.1			0.201
L		3.3			0.130	
Z	1.27		2.54	0.050		0.100

PACKAGE MECHANICAL DATA
14 PINS - PLASTIC MICROPACKAGE (SO)

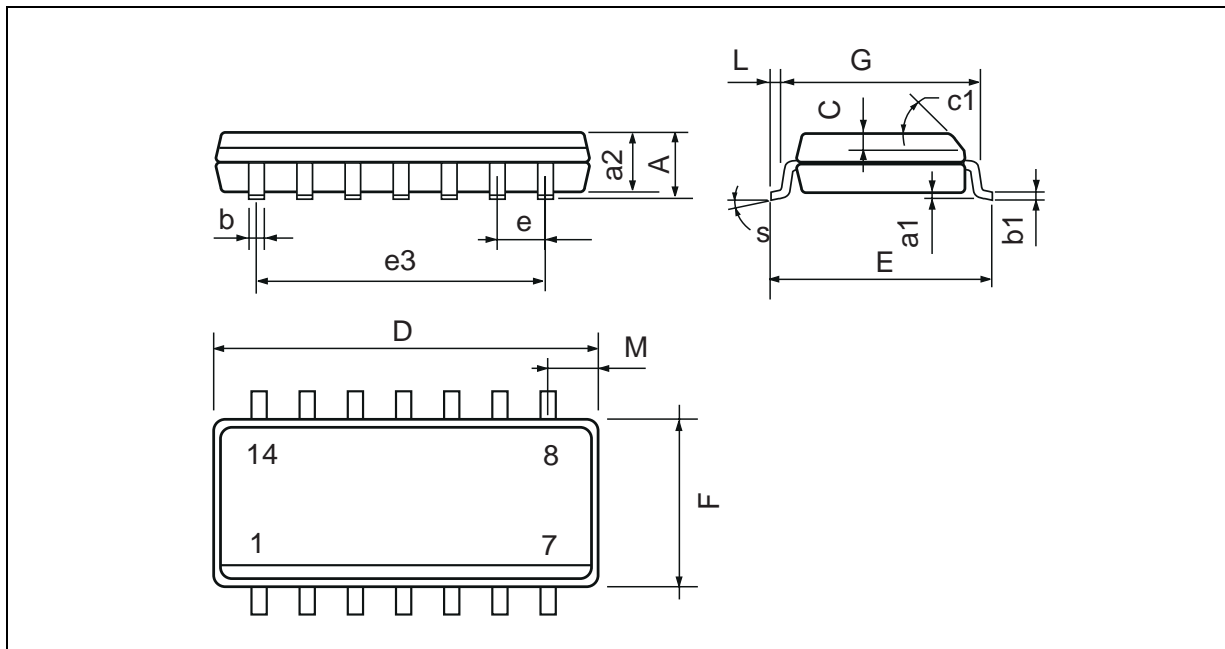

Dimensions	Millimeters			Inches		
	Min.	Typ.	Max.	Min.	Typ.	Max.
A			1.75			0.069
a1	0.1		0.2	0.004		0.008
a2			1.6			0.063
b	0.35		0.46	0.014		0.018
b1	0.19		0.25	0.007		0.010
C		0.5			0.020	
c1	45° (typ.)					
D (1)	8.55		8.75	0.336		0.344
E	5.8		6.2	0.228		0.244
e		1.27			0.050	
e3		7.62			0.300	
F (1)	3.8		4.0	0.150		0.157
G	4.6		5.3	0.181		0.208
L	0.5		1.27	0.020		0.050
M			0.68			0.027
S	8° (max.)					

Note: (1) D and F do not include mold flash or protrusions. Mold flash or protrusions shall not exceed 0.15mm (0.066 in.) ONLY FOR DATA BOOK
Information furnished is believed to be accurate and reliable. However, STMicroelectronics assumes no responsibility for the consequences of use of such information nor for any infringement of patents or other rights of third parties which may result from its use. No license is granted by implication or otherwise under any patent or patent rights of STMicroelectronics. Specifications mentioned in this publication are subject to change without notice. This publication supersedes and replaces all information previously supplied. STMicroelectronics products are not authorized for use as critical components in life support devices or systems without express written approval of STMicroelectronics.

© The ST logo is a registered trademark of STMicroelectronics

© 2002 STMicroelectronics - Printed in Italy - All Rights Reserved
STMicroelectronics GROUP OF COMPANIES

Australia - Brazil - Canada - China - Finland - France - Germany - Hong Kong - India - Israel - Italy - Japan - Malaysia
Malta - Morocco - Singapore - Spain - Sweden - Switzerland - United Kingdom - United States

© <http://www.st.com>

OUR CERTIFICATE

DiGi provide top-quality products and perfect service for customer worldwide through standardization, technological innovation and continuous improvement. DiGi through third-party certification, we stricly control the quality of products and services. Welcome your RFQ to

Email: Info@DiGi-Electronics.com



Tel: +00 852-30501935

RFQ Email: Info@DiGi-Electronics.com

DiGi is a global authorized distributor of electronic components.