

VIPER38LE Datasheet

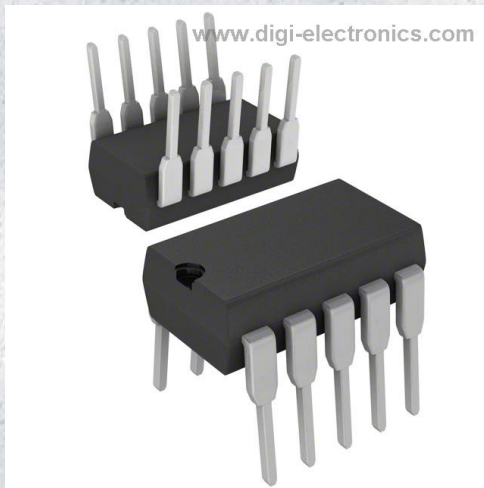

<https://www.DiGi-Electronics.com>

DiGi Electronics Part Number	VIPER38LE-DG
Manufacturer	STMicroelectronics
Manufacturer Product Number	VIPER38LE
Description	IC OFFLINE SWITCH FLYBACK 10DIP
Detailed Description	Converter Offline Flyback Topology 60kHz 10-SDIP

This model VIPER38LE is available at DiGi Electronics.

DiGi Electronics offers a global database of semiconductor and electronic component datasheets.

We welcome your inquiries regarding pricing, lead time, or other product-related questions.

 [Request a Quote](#)

 [Datasheet Search](#)



Tel: +00 852-30501935

RFQ Email: Info@DiGi-Electronics.com

DiGi is a global authorized distributor of electronic components.

Purchase and inquiry

Manufacturer Product Number:

VIPER38LE

Series:

VIPer™ plus

Output Isolation:

Isolated

Voltage - Breakdown:

800V

Voltage - Start Up:

14 V

Duty Cycle:

80%

Power (Watts):

20 W

Control Features:

-

Package / Case:

10-SDIP (0.300", 7.62mm)

Mounting Type:

Through Hole

Manufacturer:

STMicroelectronics

Product Status:

Active

Internal Switch(s):

Yes

Topology:

Flyback

Voltage - Supply (Vcc/Vdd):

8.5V ~ 23.5V

Frequency - Switching:

60kHz

Fault Protection:

Current Limiting, Over Temperature, Over Voltage, Short Circuit

Operating Temperature:

-40°C ~ 150°C (TJ)

Supplier Device Package:

10-SDIP

Base Product Number:

VIPER38

Environmental & Export classification

RoHS Status:

ROHS3 Compliant

REACH Status:

REACH Unaffected

HTSUS:

8542.39.0001

Moisture Sensitivity Level (MSL):

1 (Unlimited)

ECCN:

EAR99

VIPerPlus family: peak power high-voltage converter

Datasheet - production data

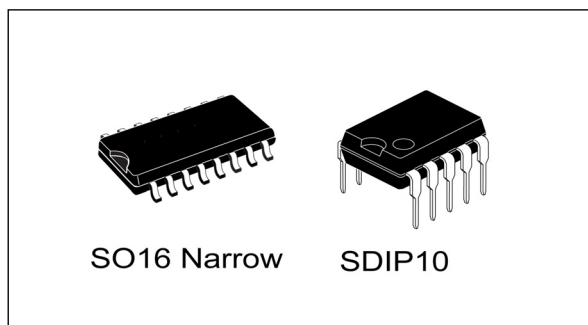
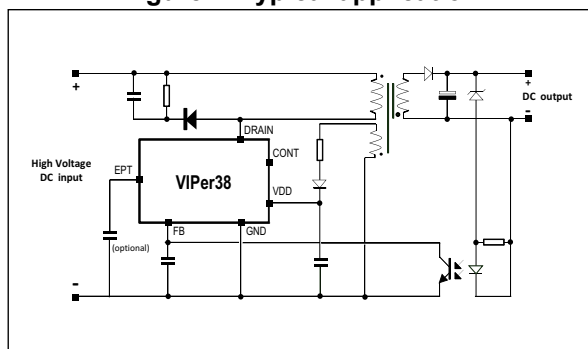

Figure 1. Typical application



Features

- 800 V avalanche-rugged power MOSFET allowing ultra wide range input V_{ac} to be achieved
- Embedded HV start-up and sense FET
- PWM current-mode controller
- OCP with selectable threshold (I_{Dlim}) and 2nd OCP with higher value (I_{DMAX}) to protect the IC from transformer saturation or short-circuit of the secondary diode
- 30 mW no-load consumption at 230 V_{ac}
- Two operating frequencies:
 - 60 kHz (L type) or 115 kHz (H type)
- Jittered frequency reduces the EMI
- Extra power timer (EPT) blanks the overload current for few seconds

- Output overvoltage protection with tight tolerance and digital noise filter
- Soft-start reduces the stress during startup and increases IC lifetime
- Automatic restart after a fault condition
- Thermal shutdown increases system reliability and IC lifetime

Applications

- Auxiliary power supply for consumer and home equipment
- Power supply for energy meters and data concentrators
- Adapters

Description

The device is a high-voltage converter that smartly integrates an 800 V rugged power MOSFET with PWM current-mode control. The power MOSFET allows a very high input V_{ac} to be applied, just limited from its breakdown voltage. This IC is capable of meeting more stringent energy-saving standards as it has very low consumption and operates in burst mode under light load.

The device features an adjustable extra power timer (EPT) that enables the IC to sustain overload conditions for a few seconds.

The integrated HV startup, sense FET and oscillator with jitter allow the advantage of using minimal components in the application.

The device features high-level protections like dual-level OCP, output overvoltage, short-circuit, and thermal shutdown with hysteresis. After the removal of a fault condition, the IC is automatically restarted.

Contents

1	Block diagram	5
2	Typical power	5
3	Pin settings	6
4	Electrical characteristics	7
5	Typical electrical characteristics	11
6	Typical circuit	13
7	Operation	14
7.1	Power section and gate driver	14
7.2	High-voltage startup generator	14
7.3	Power-up and soft startup	14
7.4	Power-down	17
7.5	Auto-restart	17
7.6	Oscillator	17
7.7	Current mode conversion with adjustable current limit setpoint	18
7.8	Overvoltage protection (OVP)	18
7.9	About CONT pin	19
7.10	Feedback and overload protection (OLP)	20
7.11	Burst-mode operation at no load or very light load	22
7.12	Extra power timer (EPT)	22
7.13	2nd level overcurrent protection and hiccup mode	23
8	Package information	24
8.1	SDIP10 package information	24
8.2	SO16 Narrow package information	26
9	Order code	28
10	Revision history	29

List of tables

Table 1.	Typical power	5
Table 2.	Pin description	6
Table 3.	Absolute maximum ratings	7
Table 4.	Thermal data	7
Table 5.	Avalanche ratings	7
Table 6.	Power section	8
Table 7.	Supply section	8
Table 8.	Controller section	9
Table 9.	CONT pin configurations.	19
Table 10.	SDIP10 mechanical data	25
Table 11.	SO16 narrow mechanical data	27
Table 12.	Order code	28
Table 13.	Document revision history.	29

List of figures

Figure 1.	Typical application	1
Figure 2.	Block diagram	5
Figure 3.	Connection diagram (top view)	6
Figure 4.	Minimum turn-on time test circuit	10
Figure 5.	OVP threshold test circuit	10
Figure 6.	I_{Dlim} vs. T_J	11
Figure 7.	F_{OSC} vs. T_J	11
Figure 8.	V_{DRAIN_START} vs. T_J	11
Figure 9.	I_{DD0} vs. T_J	11
Figure 10.	I_{DD1} vs. T_J	11
Figure 11.	Main FET R_{DSON} vs. T_J	11
Figure 12.	Main FET V_{BVDSS} vs. T_J	12
Figure 13.	I_{Dlim} vs. R_{LIM}	12
Figure 14.	Thermal shutdown	12
Figure 15.	Basic flyback application	13
Figure 16.	Full-featured flyback application	13
Figure 17.	IDD current during startup and burst mode	15
Figure 18.	Timing diagram: normal power-up and power-down sequences	16
Figure 19.	Soft-start: timing diagram	16
Figure 20.	Timing diagram: behavior after short-circuit	17
Figure 21.	CONT pin configuration	19
Figure 22.	FB pin configuration (option 1)	21
Figure 23.	FB pin configuration (option 2)	21
Figure 24.	Burst mode timing diagram, light load	22
Figure 25.	EPT timing diagram	23
Figure 26.	SDIP10 package outline	24
Figure 27.	SO16 Narrow package outline	26

1 Block diagram

Figure 2. Block diagram

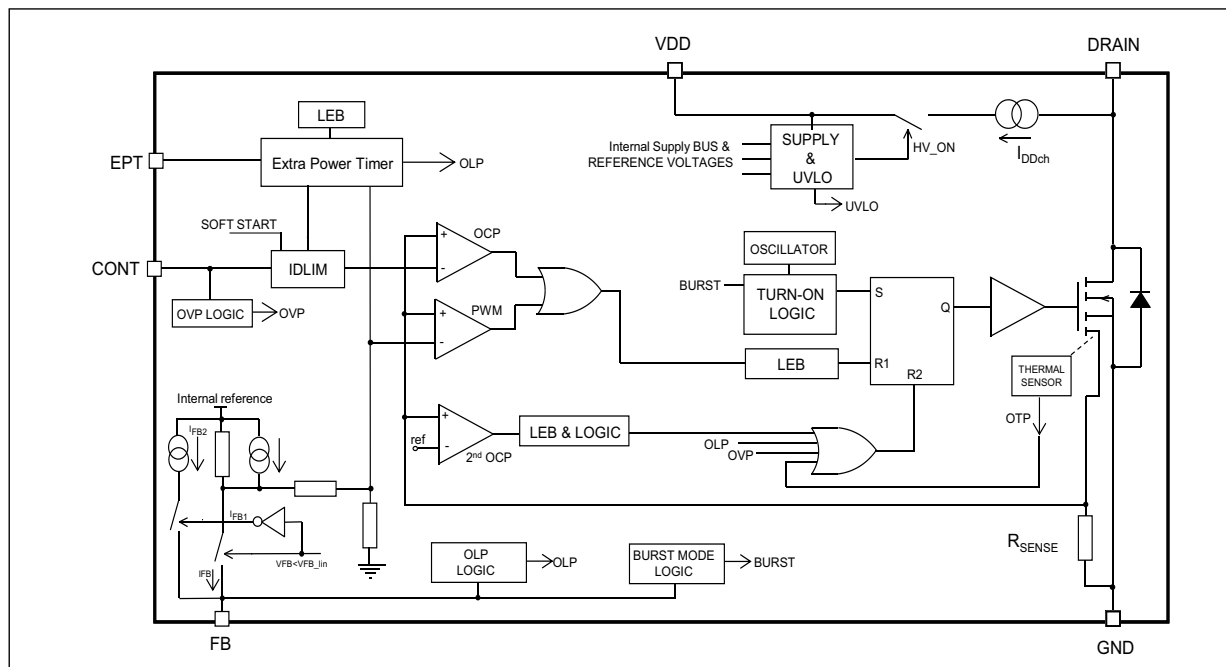

2 Typical power

Table 1. Typical power

Nominal power	230 V _{AC}		85-265 V _{AC}	
	Adapter ⁽¹⁾	Open frame ⁽²⁾	Adapter ⁽¹⁾	Open frame ⁽²⁾
VIPER38	18 W	20 W	13 W	15 W
	28 W (peak) ⁽³⁾	30 W (peak) ⁽³⁾	23 W (peak) ⁽³⁾	25 W (peak) ⁽³⁾

1. Typical continuous power in non-ventilated enclosed adapter measured at 50 °C ambient.
2. Maximum practical continuous power in an open frame design at 50 °C ambient, with adequate heat sinking.
3. Maximum practical peak power at 50 °C ambient, with adequate heat sinking for 2 sec (max).

3 Pin settings

Figure 3. Connection diagram (top view)

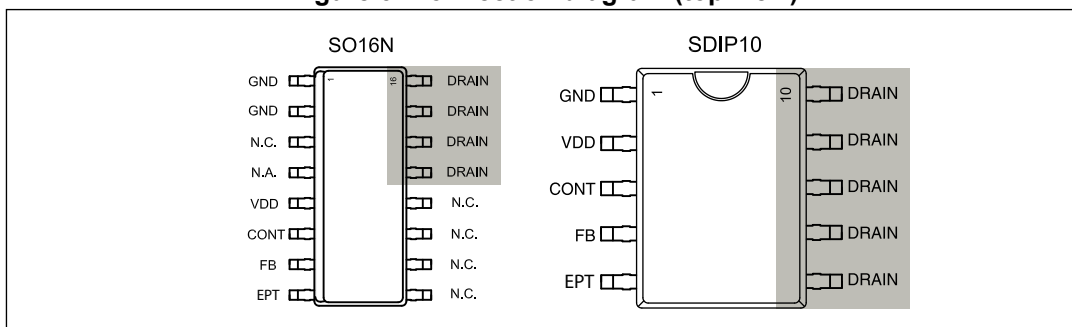

Note: The copper area for heat dissipation has to be designed under the DRAIN pins.

Table 2. Pin description

SO16N	Name	Function
1, 2	GND	Device ground and source of the power MOSFET.
3	N.C.	Not connected.
4	N.A.	Not available for user. This pin is mechanically connected to the controller die pad of the frame. In order to improve the noise immunity, is highly recommended connect it to GND (pin 1-2).
5	VDD	Supply voltage of the control section. This pin also provides the charging current of the external capacitor during startup.
6	CONT	Control pin. The following functions can be selected: 1. current limit setpoint adjustment. The default value (set internally) of the cycle-by-cycle current limit can be reduced by connecting an external resistor to ground. 2. output voltage monitoring. A voltage exceeding the V_{OVP} threshold (see Table 8: Controller section on page 9) shuts the IC down, reducing device consumption. This function is strobed and digitally filtered for high noise immunity.
7	FB	Control input for duty cycle control. The internal current generator provides bias current for loop regulation. A voltage below the threshold V_{FBbm} activates burst-mode operation. A level close to the threshold V_{FBlin} means that we are approaching the cycle-by-cycle overcurrent setpoint.
8	EPT	This pin allows the connection of an external capacitor for extra power management. If the function is not used, the pin has to be connected to GND.
9...12	N.C.	Not connected.
13...16	DRAIN	High-voltage drain pin. The built-in high-voltage switched startup bias current is drawn from this pin too. These pins are connected to the metal frame to facilitate heat dissipation.

4 Electrical characteristics

Table 3. Absolute maximum ratings

Symbol	Parameter	Value		Unit
		Min	Max	
V _{DRAIN}	Drain-to-source (ground) voltage		800	V
I _{DRAIN}	Pulse drain current (limited by T _J = 150 °C)		3	A
V _{CONT}	Control input pin voltage	-0.3	6	V
V _{FB}	Feedback voltage	-0.3	5.5	V
V _{EPT}	EPT input pin voltage	-0.3	5	V
V _{DD}	Supply voltage (I _{DD} = 25 mA)	-0.3	Self limited	V
I _{DD}	Input current		25	mA
P _{TOT}	Power dissipation at T _A < 60 °C		1.5	W
T _J	Operating junction temperature range	-40	150	°C
T _{STG}	Storage temperature	-55	150	°C

Table 4. Thermal data

Symbol	Parameter	Max		Unit
		SDIP10	SO16N	
R _{TH-JC}	Thermal resistance junction to case ⁽¹⁾ (Dissipated power = 1 W)	5	10	°C/W
R _{TH-JA}	Thermal resistance junction ambient ⁽¹⁾ (Dissipated power = 1 W)	105	120	°C/W
R _{TH-JC}	Thermal resistance junction to case ⁽²⁾ (Dissipated power = 1 W)	5	5	°C/W
R _{TH-JA}	Thermal resistance junction ambient ⁽²⁾ (Dissipated power = 1 W)	90	85	°C/W

1. When mounted on a standard, single side FR4 board with minimum copper area.
2. When mounted on a standard, single side FR4 board with 100 mm² of Cu (35 μm thick).

Table 5. Avalanche ratings

Symbol	Parameter	Test condition	Value	Unit
I _{AS}	Avalanche current	Repetitive or non repetitive (pulse width limited by T _{Jmax})	1.15	A
E _{AS}	Single pulse avalanche energy ⁽¹⁾	I _D = I _{AS} , V _{DS} = 100 V starting T _J = 25°C	5	mJ

1. Specification assured by design and characterization.

Electrical characteristics

VIPER38

$T_J = -25$ to 125 °C, $V_{DD} = 14$ V; unless otherwise specified (adjust V_{DD} above V_{DDon} startup threshold before setting to 14 V).

Table 6. Power section

Symbol	Parameter	Test condition	Min	Typ	Max	Unit
V_{BVDSS}	Breakdown voltage	$I_{DRAIN} = 1$ mA, $V_{FB} = GND$, $T_J = 25$ °C	800			V
I_{OFF}	OFF-state drain current	$V_{DRAIN} = \text{max rating}$, $V_{FB} = GND$, $T_J = 25$ °C			60	μ A
$R_{DS(on)}$	Drain-source on-state resistance	$I_{DRAIN} = 0.4$ A, $V_{FB} = 3$ V, $V_{EPT} = GND$, $T_J = 25$ °C			4.5	Ω
		$I_{DRAIN} = 0.4$ A, $V_{FB} = 3$ V, $V_{EPT} = GND$, $T_J = 125$ °C			9	Ω
C_{OSS}	Effective (energy related) output capacitance	$V_{DRAIN} = 0$ to 640 V, $T_J = 25$ °C		17		pF

Table 7. Supply section

Symbol	Parameter	Test condition	Min	Typ	Max	Unit
Voltage						
V_{DRAIN_START}	Drain-source start voltage		60	80	100	V
I_{DDch1}	Startup charging current	$V_{DRAIN} = 120$ V, $V_{EPT} = GND$, $V_{FB} = GND$, $V_{DD} = 4$ V	-2	-3	-4	mA
I_{DDch2}	Restart charging current (after fault)	$V_{DRAIN} = 120$ V, $V_{EPT} = GND$, $V_{FB} = GND$, $V_{DD} = 4$ V	-0.4	-0.6	-0.8	mA
V_{DD}	Operating voltage range	After turn-on	8.5		23.5	V
$V_{DDclamp}$	V_{DD} clamp voltage	$I_{DD} = 20$ mA	23.5			V
V_{DDon}	V_{DD} startup threshold	$V_{DRAIN} = 120$ V, $V_{EPT} = GND$, $V_{FB} = GND$	13	14	15	V
V_{DDoff}	V_{DD} undervoltage shutdown threshold		7.5	8	8.5	V
$V_{DD(RESTART)}$	V_{DD} restart voltage threshold	$V_{DRAIN} = 120$ V, $V_{EPT} = GND$, $V_{FB} = GND$	4	4.5	5	V
Current						
I_{DD0}	Operating supply current, not switching	$V_{FB} = GND$, $F_{OSC} = 0$ kHz $V_{EPT} = GND$, $V_{DD} = 10$ V			0.7	mA
I_{DD1}	Operating supply current, switching	$V_{DRAIN} = 120$ V, $F_{OSC} = 60$ kHz			2.5	mA
		$V_{DRAIN} = 120$ V, $F_{OSC} = 115$ kHz			3.5	mA
I_{DD_FAULT}	Operating supply current, with protection tripping	$V_{DD} = 10$ V			400	μ A
I_{DD_OFF}	Operating supply current with $V_{DD} < V_{DD_OFF}$	$V_{DD} = 7$ V			270	μ A

Table 8. Controller section

Symbol	Parameter	Test condition	Min	Typ	Max	Unit
Feed-back pin						
V_{FBolp}	Overload shutdown threshold		4.5	4.8	5.2	V
V_{FBlin}	Overload detection threshold		3.2	3.5	3.7	V
V_{FBbm}	Burst mode threshold	Voltage falling	0.54	0.6	0.66	V
$V_{FBbmhys}$	Burst mode hysteresis	Voltage rising		90		mV
I_{FB1}	Feedback sourced current	$V_{FB} = 0.3\text{ V}$	-150	-200	-280	uA
I_{FB2}	Feedback current-OLP delay	$V_{FBlin} < V_{FB} < V_{FBolp}$		-3		uA
$R_{FB(DYN)}$	Dynamic resistance	$V_{FB} < 3.3\text{ V}$	14		21	k Ω
H_{FB}	$\Delta V_{FB} / \Delta I_D$		0.5		2	V/A
CONT pin						
V_{CONT_l}	Low-level clamp voltage	$I_{CONT} = -100\ \mu\text{A}$	0.4	0.5	0.6	V
V_{CONT_h}	High-level clamp voltage	$I_{CONT} = 1\text{ mA}$	5	5.5	6	V
Current limitation						
I_{Dlim}	Max drain current limitation	$V_{FB} = 4\text{ V}$, $I_{CONT} = -10\ \mu\text{A}$ $T_J = 25\text{ }^\circ\text{C}$	1.07	1.15	1.23	A
t_{SS}	Soft-start time		7.6	8.5	9.4	ms
t_{ON_MIN}	Minimum turn-on time		220	400	480	ns
t_d	Propagation delay	(1)		20		ns
t_{LEB}	Leading edge blanking	(1)		380		ns
I_{D_BM}	Peak drain current during burst mode	$V_{FB} = 0.6\text{ V}$	115	190	265	mA
Oscillator section						
F_{OSC}	$V_{FB} = 1\text{ V}$	VIPER38L	54	60	66	kHz
		VIPER38H	103	115	127	kHz
FD	Modulation depth	VIPER38L		± 4		kHz
		VIPER38H		± 8		kHz
FM	Modulation frequency		830	920	1010	Hz
D_{MAX}	Maximum duty cycle		70		80	%
Overcurrent protection (2nd OCP)						
I_{DMAX}	Second overcurrent threshold			1.7		A
Overvoltage protection						
V_{OVP}	Overvoltage protection threshold		2.7	3	3.3	V
t_{STROBE}	Overvoltage protection strobe time		1.5	2	2.5	μs

Electrical characteristics

VIPER38

Table 8. Controller section (continued)

Symbol	Parameter	Test condition	Min	Typ	Max	Unit
Extra power management						
I_{DLIM_EPT}	Drain current limit with EPT function	(1)		85% I_{Dim}		A
$V_{EPT(STOP)}$	EPT shutdown threshold	$I_{CONT} < -10 \mu A$	3.6	4	4.4	V
$V_{EPT(RESTART)}$	EPT restart threshold		0.4	0.6	0.8	V
I_{EPT}	Sink/source current		4	5	6	μA
Thermal shutdown						
T_{SD}	Thermal shutdown temperature	(1)	150	160		$^{\circ}C$
T_{HYST}	Thermal shutdown hysteresis	(1)		30		$^{\circ}C$

1. Specification assured by design, characterization and statistical correlation.

Figure 4. Minimum turn-on time test circuit

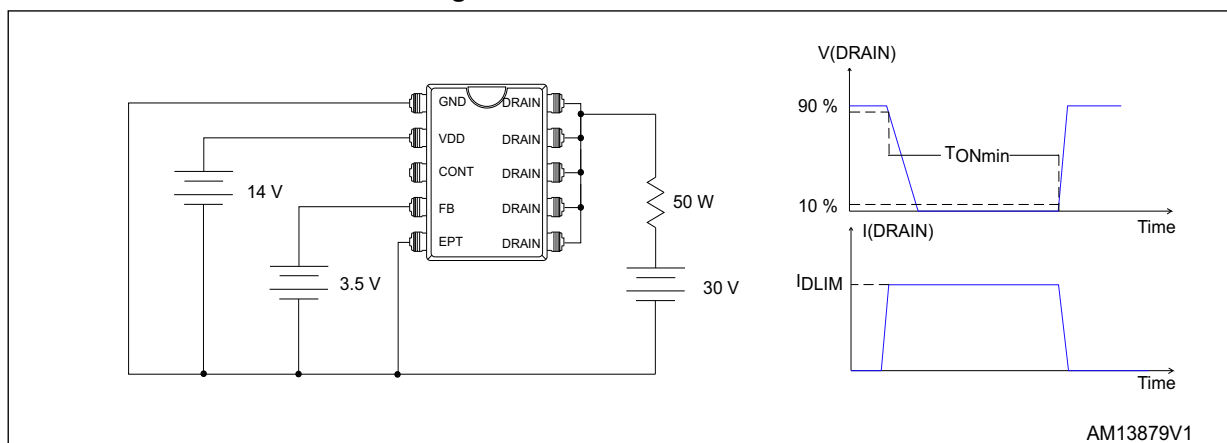
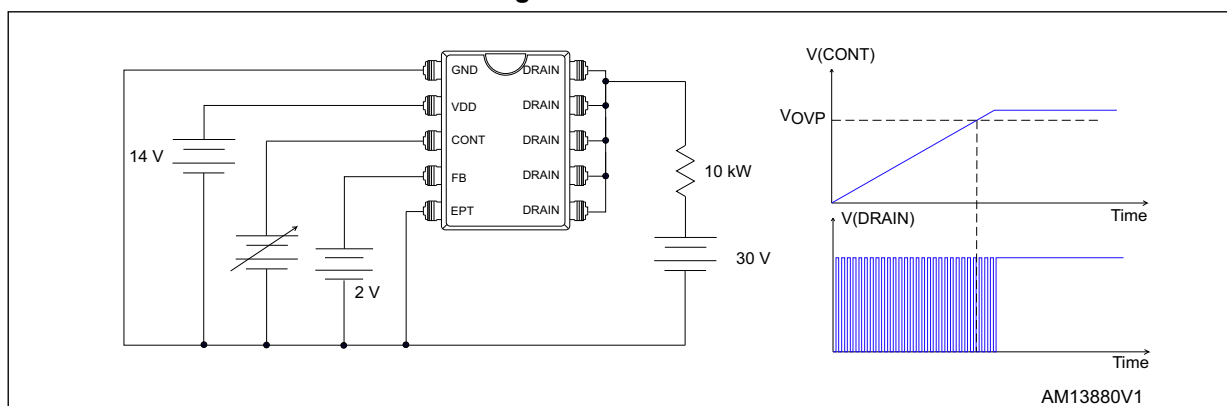
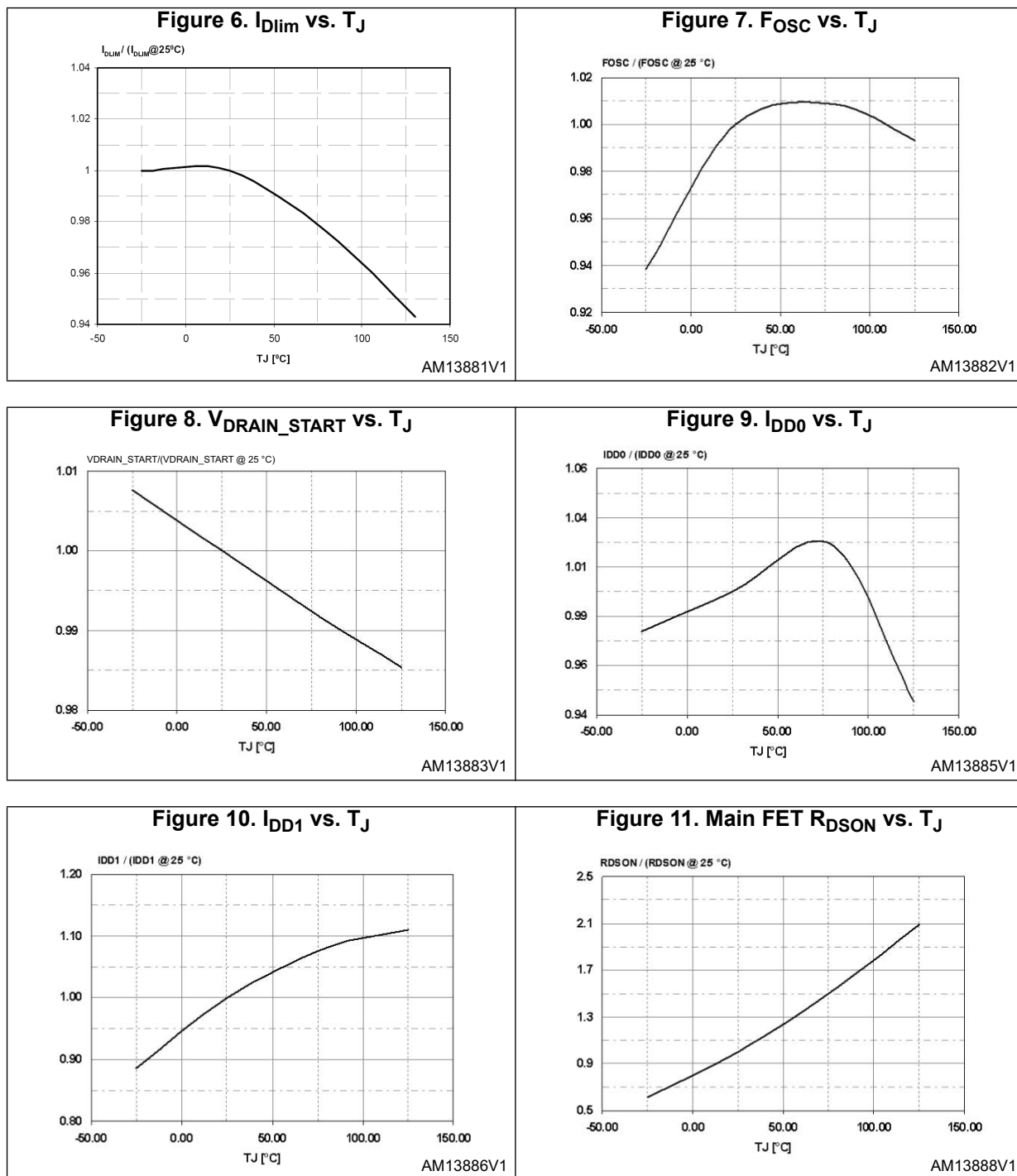

Figure 5. OVP threshold test circuit



Note: Adjust VDD above VDDon startup threshold before setting to 14 V.

5 Typical electrical characteristics



Typical electrical characteristics

VIPER38

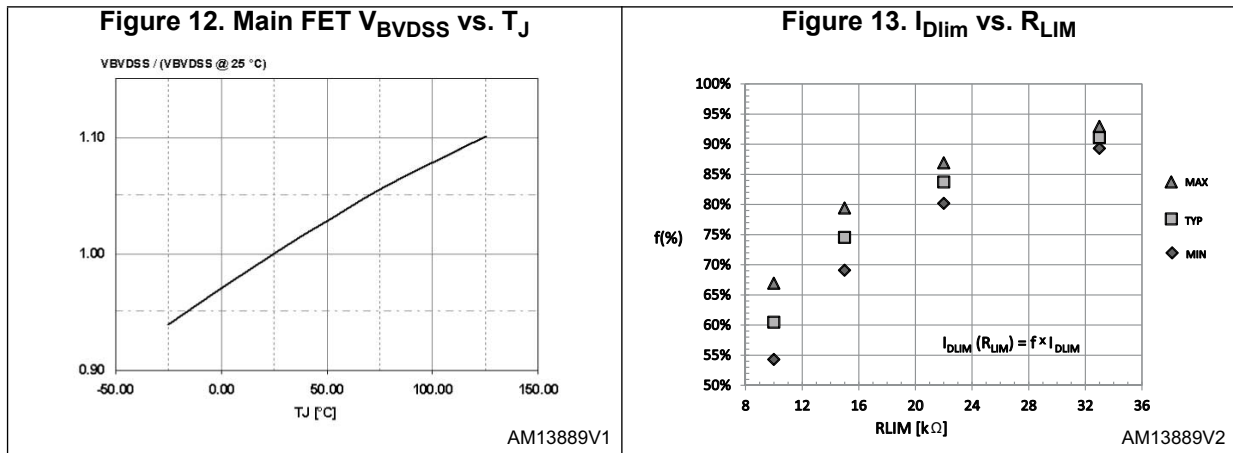
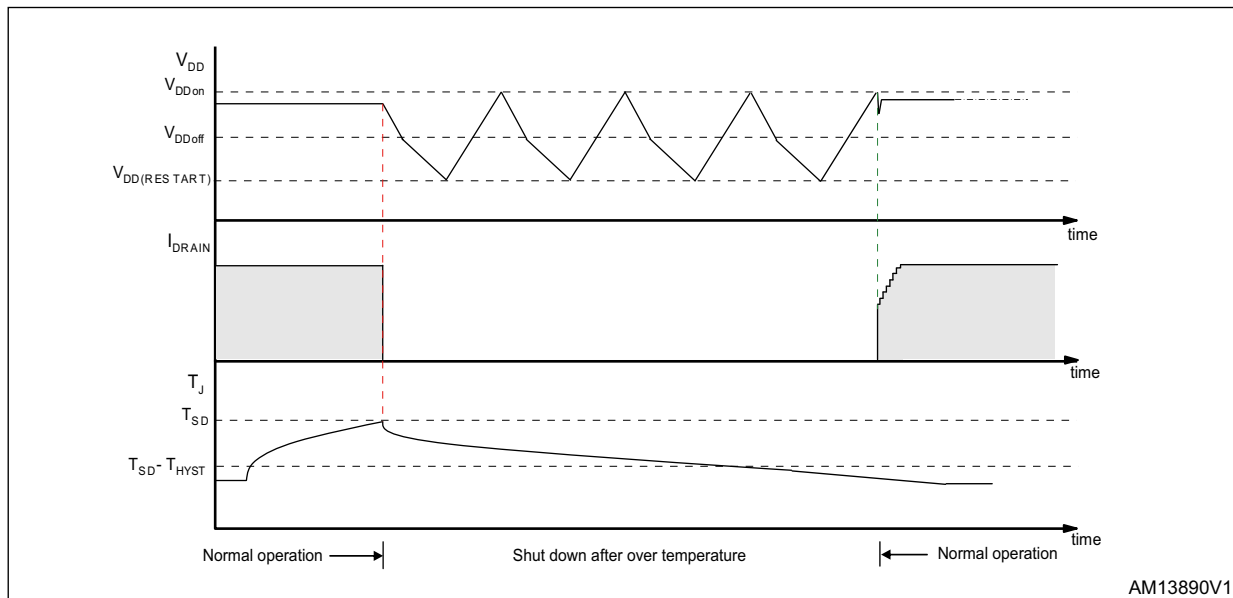

Figure 14. Thermal shutdown



6 Typical circuit

Figure 15. Basic flyback application

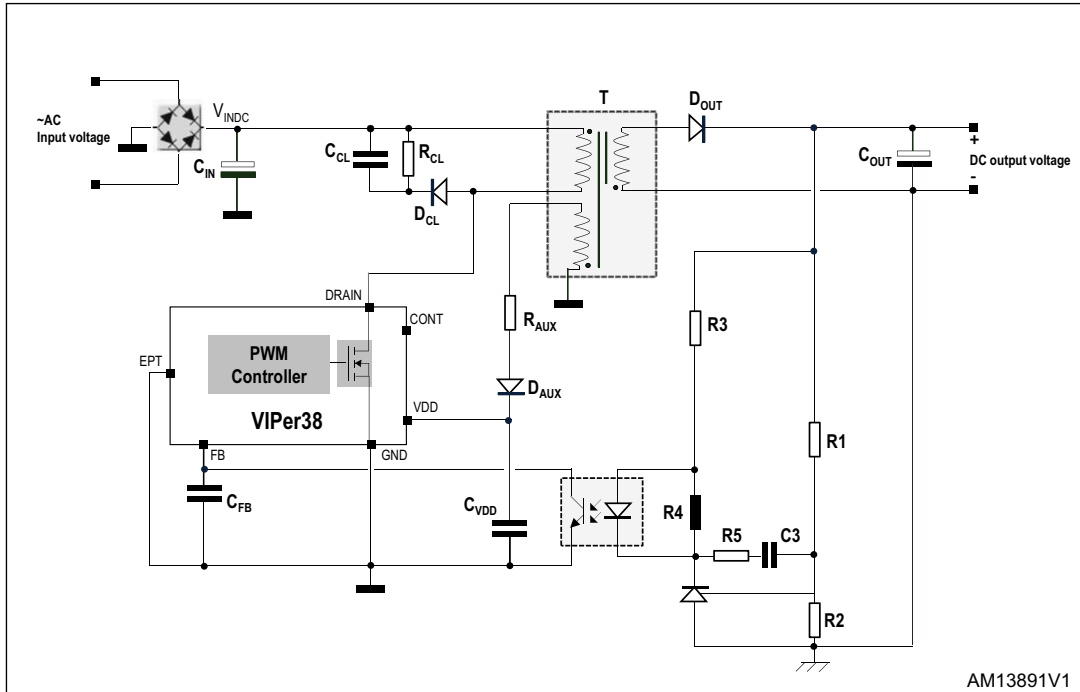
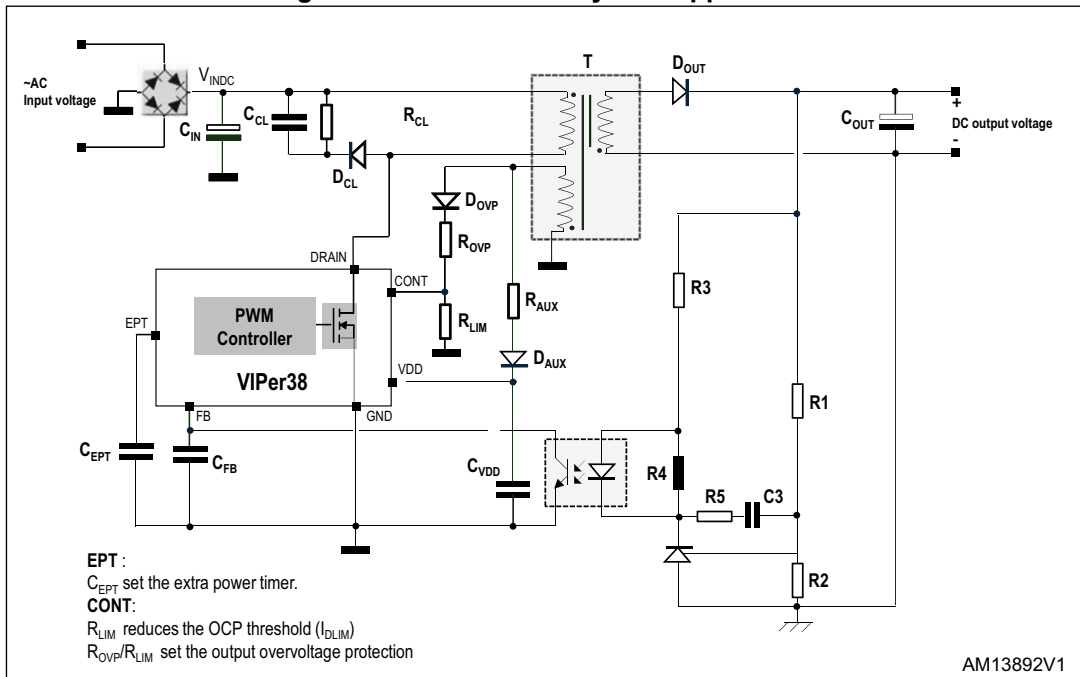

Figure 16. Full-featured flyback application



7 Operation

The device is a high-performance low-voltage PWM controller chip with an 800 V, avalanche rugged power section.

The controller includes the oscillator with jitter, startup circuit with soft-start, PWM logic, current limiting circuit with adjustable setpoint, second overcurrent circuit, burst mode management, extra power timer circuit, UVLO circuit, auto-restart circuit and thermal protection circuit.

The current limit setpoint is set by the CONT pin. Burst mode operation guarantees high performance in standby mode and contributes to meeting energy-saving standards.

All the fault protections are built in auto-restart mode with very low repetition rate to prevent the IC from overheating.

7.1 Power section and gate driver

The power section is implemented with an avalanche-rugged N-channel MOSFET, which guarantees safe operation within the specified energy rating as well as high dv/dt capability. The power section has a $B_{V_{DS}}$ of 800 V min. and a typical $R_{DS(on)}$ of 4.5 Ω at 25 °C.

The integrated SenseFET structure allows a virtually loss-less current sensing.

The gate driver is designed to supply a controlled gate current during both turn-on and turn-off in order to minimize common-mode EMI. Under UVLO conditions an internal pull-down circuit holds the gate low in order to ensure that the power section cannot be turned on accidentally.

7.2 High-voltage startup generator

The HV current generator is supplied through the DRAIN pin and it is enabled only if the input bulk capacitor voltage is higher than the V_{DRAIN_START} threshold, 80 V DC typically. When the HV current generator is ON, the I_{DDch1} current (3 mA typical value) is delivered to the capacitor on the V_{DD} pin. During auto-restart mode after a fault event, the current is reduced to I_{DDch2} (0.6 mA, typ) in order to have a slow duty cycle during the restart phase.

7.3 Power-up and soft startup

When the input voltage rises to the device start threshold, V_{DRAIN_START} , the V_{DD} voltage begins to grow due to the I_{DDch1} current (see [Table 7: Supply section](#)) coming from the internal high-voltage startup circuit. If the V_{DD} voltage reaches the V_{DDon} threshold, the power MOSFET starts switching and the HV current generator is turned OFF.

The IC is powered by the energy stored in the capacitor on the V_{DD} pin, C_{VDD} , until the self-supply circuit (typically an auxiliary winding of the transformer and a steering diode) develops a voltage high enough to sustain the operation.

The C_{VDD} capacitor must be correctly sized to avoid fast discharge and keep the required voltage higher than the V_{DDoff} threshold. In fact, an insufficient capacitance value could terminate the switching operation before the controller receives any energy from the auxiliary winding.

The following formula can be used for the C_{VDD} capacitor calculation:

Equation 1

$$C_{VDD} = \frac{I_{DDch1} \times t_{SSaux}}{V_{DDon} - V_{DDoff}}$$

The parameter t_{SSaux} is the time needed for the steady state of the auxiliary voltage. This time represents an estimate of the user's application according to the output stage configurations (transformer, output capacitances, etc.).

During the converter startup time, the drain current limitation is progressively increased to the maximum value. In this way the stress on the secondary diode is considerably reduced. It also helps to prevent transformer saturation. The soft-start time lasts 8.5 ms and the feature is implemented for every attempt of the startup converter or after a fault.

Figure 17. I_{DD} current during startup and burst mode

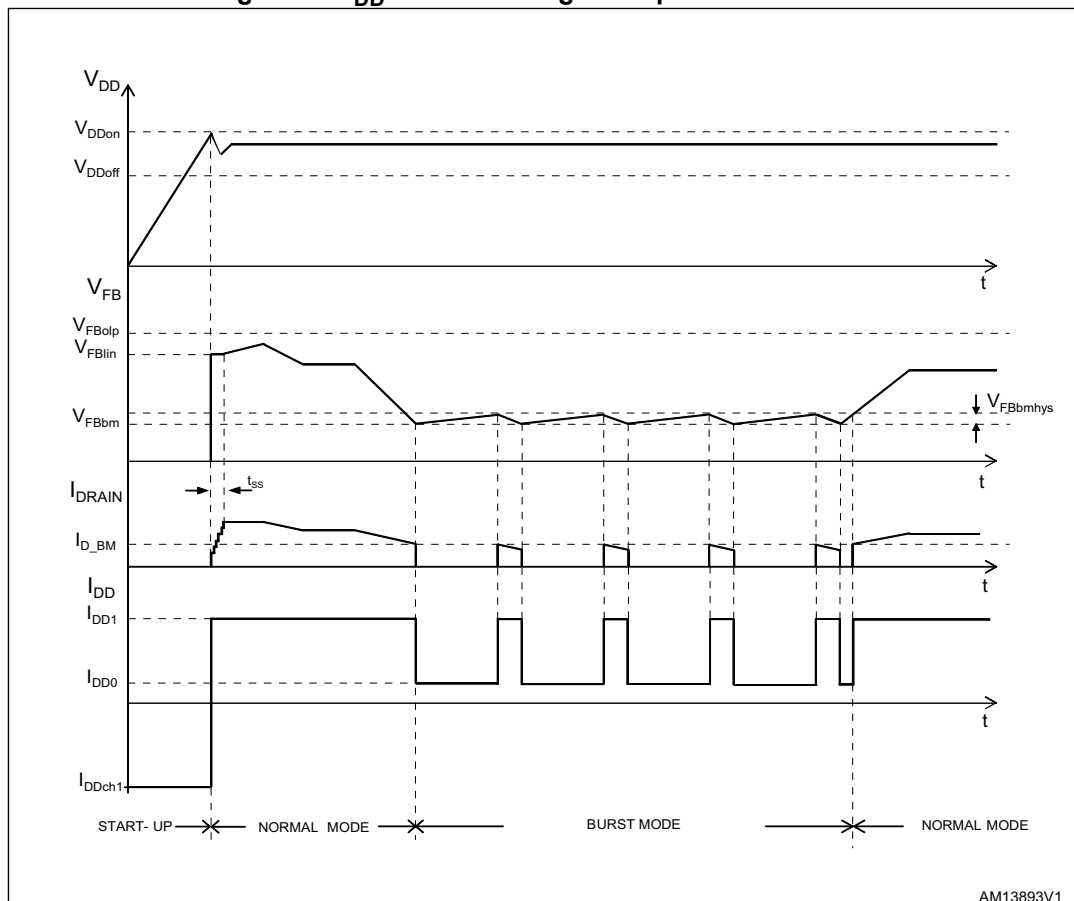

Figure 18. Timing diagram: normal power-up and power-down sequences

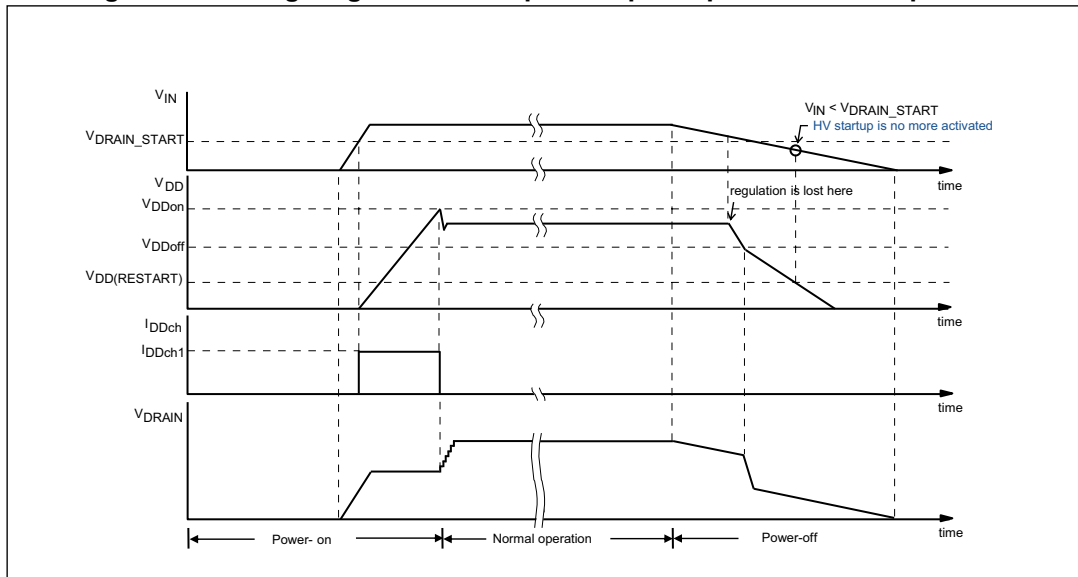
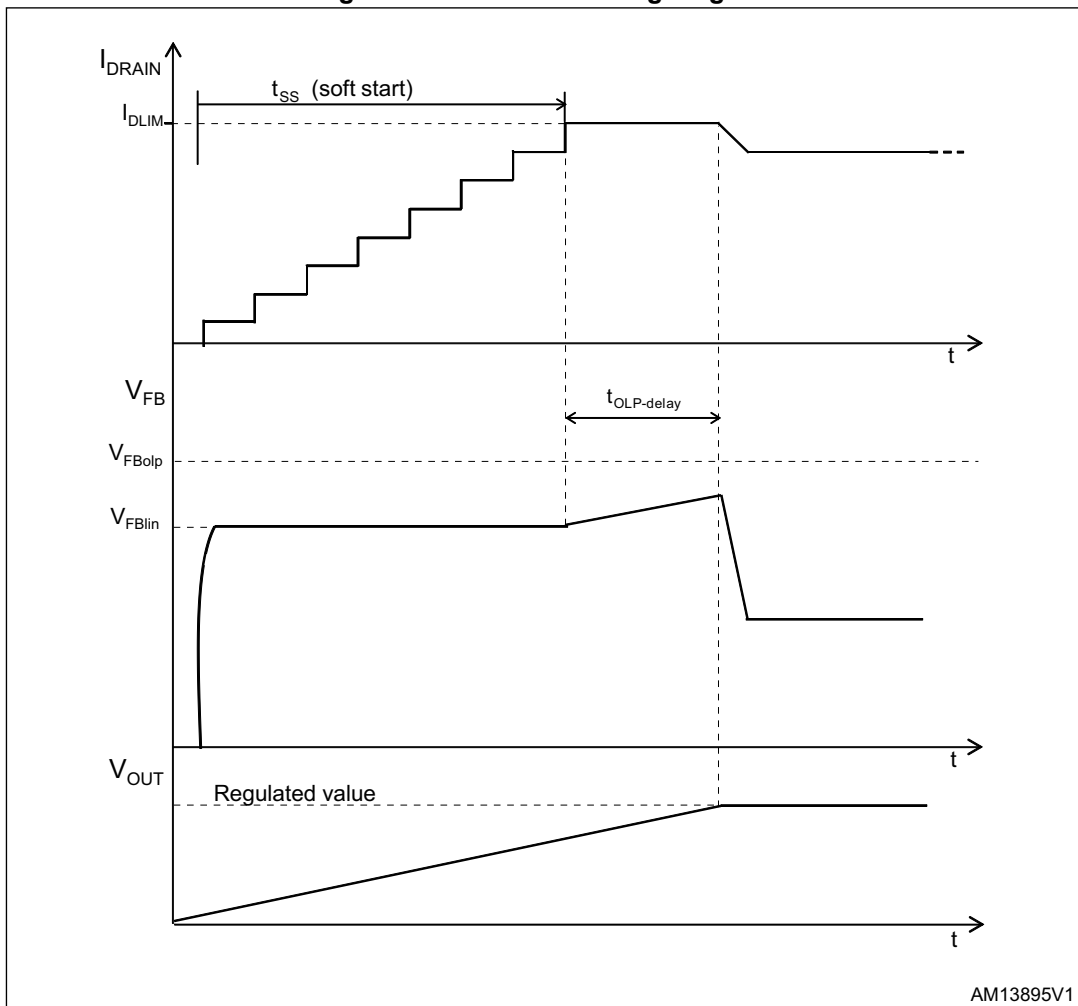

Figure 19. Soft-start: timing diagram



AM13895V1

7.7 Current mode conversion with adjustable current limit setpoint

The device is a current mode converter. The drain current is sensed and converted to voltage that is applied to the non-inverting pin of the PWM comparator. This voltage is compared with the one on the feedback pin through a voltage divider on a cycle-by-cycle basis.

The device has a default current limit value, I_{Dlim} , that can be adjusted according to the electrical specification, by the R_{LIM} resistor connected to the CONT pin.

The CONT pin has a minimum current sunk needed to activate the I_{Dlim} adjustment. Without R_{LIM} or with high R_{LIM} (i.e. 100 k Ω) the current limit is set to the default value (see I_{Dlim} , [Table 8: Controller section](#)).

7.8 Overvoltage protection (OVP)

The device has an integrated logic for the monitoring of the output voltage using as an input signal the voltage VCONT during the OFF time of the power MOSFET. This is the time when the voltage from the auxiliary winding tracks the output voltage, through the turn ratio.

The CONT pin has to be connected to the auxiliary winding through the diode DOVP and the resistors ROVP and RLIM as shown in [Figure 22: CONT pin configuration](#). When, during the OFF time, the voltage VCONT exceeds four consecutive times the reference voltage VOVP (see [Table 8: Controller section](#)), the overvoltage protection will stop the power MOSFET and the converter enters auto-restart mode.

In order to bypass the noise immediately after the turn-off of the power MOSFET, the voltage VCONT is sampled inside a short window after the time TSTROBE, see [Table 8: Controller section](#) and the [Figure 21: OVP timing diagram](#). The sampled signal, if higher than VOVP, triggers the internal OVP digital signal and increments the internal counter. The same counter is reset every time the signal OVP is not triggered in one oscillator cycle.

Referring to [Figure 22: CONT pin configuration](#), once fixing RLIM according to the desired IDlim, the ROVP can be calculated by::

Equation 2

$$R_{OVP} = \frac{(V_{OUTOVP} + V_{DSEC}) \cdot \frac{N_{AUX}}{N_{SEC}} - V_{OVP} - V_{DAUX}}{I_{CONT} + \frac{V_{OVP}}{R_{LIM}}}$$

Where:

- V_{OVP} is the OVP threshold (see [Table 8: Controller section](#))
- V_{OUTOVP} is the converter output voltage value to activate the OVP set by the designer
- N_{AUX} is the number of the auxiliary winding turns
- N_{SEC} is the number of the secondary winding turns
- V_{DSEC} is the secondary diode forward voltage
- V_{DAUX} is the auxiliary diode forward voltage

- I_{CONT} is the current sunk by the CONT pin during the Mosfet off-time and is 10 μ A typical value.
- R_{OVP} together with R_{LIM} constitute the output voltage divider

In the above formula, the effect of the not perfect coupling between the windings can be also considered, using the transformer's coupling parameter, K_T .

In this case the ratio N_{AUX}/N_{SEC} is replaced by the quantity $K_T \cdot (N_{AUX}/N_{SEC})$, where K_T is in the range 0.98-0.9, depending on the transformer's construction technique.

7.9 About CONT pin

Referring to [Figure 23](#), the CONT pin is used to configure the:

1. reduction of the OCP setpoint (I_{DLIM})
2. output overvoltage protection (OVP)

[Table 10](#) lists the external components needed to activate one or more of the CONT pin functions.

Figure 21. CONT pin configuration

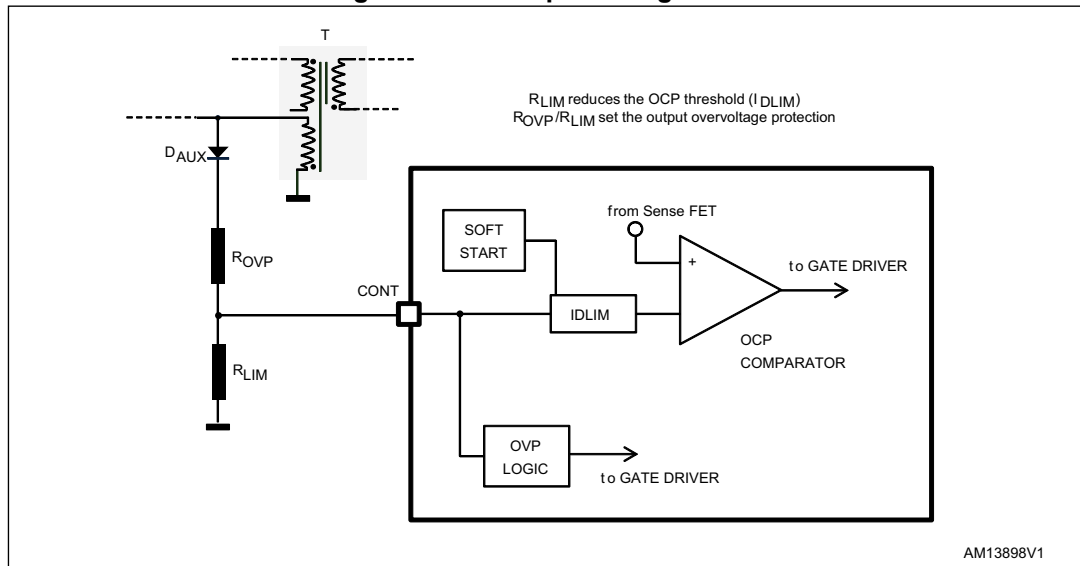

Table 9. CONT pin configurations

Function / component	R_{LIM}	R_{OVP}	D_{AUX}
I_{Dlim} reduction	See Figure 13	No	No
OVP	$\geq 80 \text{ k}\Omega$	See Equation 4	Yes
I_{Dlim} reduction and OVP ⁽¹⁾	See Figure 13	See Equation 4	Yes

1. Select R_{LIM} hen R_{OVP} .

7.10 Feedback and overload protection (OLP)

The device is a current-mode converter. The feedback pin controls PWM operation as well as burst mode and activates the overload protection. [Figure 22: FB pin configuration \(option 1\)](#) and [Figure 23: FB pin configuration \(option 2\)](#) show the internal current-mode structure.

With the feedback pin voltage between V_{FBbm} and V_{FBlin} , (see [Table 8: Controller section](#)) the drain current is sensed and converted to voltage that is applied to the non-inverting pin of the PWM comparator.

This voltage is compared to the voltage on the feedback pin through a voltage divider on a cycle-by-cycle basis. When these two voltages are equal, the PWM logic orders the switch-off of the power MOSFET. The drain current is always limited to the value of I_{Dlim} .

When the feedback pin voltage reaches the threshold V_{FBlin} , an internal current generator starts to charge the feedback capacitor (C_{FB}) and when the feedback voltage reaches the V_{FBolp} threshold, the converter is turned off and the automatic restart is activated.

During startup, when the output voltage is still low, if the feedback network is not properly dimensioned, the feedback voltage could rise up to the overload threshold (V_{FBolp}) generating the switching off of the IC itself. Taking into account that the feedback network also fixes the loop stability, two options can be considered for this network.

The time from the overload detection ($V_{FB} = V_{FBlin}$) to the device shutdown ($V_{FB} = V_{FBolp}$) must be set by C_{FB} (or C_{FB1}) using the formula:

Equation 3

$$T_{OLP_delay} = C_{FB} \times \frac{V_{FBolp} - V_{FBlin}}{I_{FB2}}$$

In the option 1 shown in [Figure 22: FB pin configuration \(option 1\)](#), the capacitor C_{FB} has a dual function: guaranteeing the loop compensation and fixing the overload delay time as calculated in [Equation 3](#).

Owing to the above considerations, the OLP delay time must be long enough to bypass the initial output voltage transient and check the overload condition only when the output voltage is in steady state. The output transient time depends on the value of the output capacitor and on the load.

When the value of the C_{FB} capacitor calculated for the loop stability is too low and cannot ensure enough OLP delay, an alternative compensation network can be used and it is shown in [Figure 23: FB pin configuration \(option 2\)](#).

Using this alternative compensation network, two poles (f_{PFB} , f_{PFB1}) and one zero (f_{ZFB}) are introduced by the capacitors C_{FB} and C_{FB1} and the resistor R_{FB1} .

The capacitor C_{FB} introduces a pole (f_{PFB}) at higher frequency than f_{ZB} and f_{PFB1} . This pole is usually used to compensate the high-frequency zero due to the ESR (equivalent series resistor) of the output capacitance of the flyback converter.

The mathematical expressions of these poles and zero frequency are:

$$f_{ZFB} = \frac{1}{2 \cdot \pi \cdot C_{FB1} \cdot R_{FB1}}$$

Equation 4

$$f_{PFB} = \frac{R_{FB(DYN)} + R_{FB1}}{2 \cdot \pi \cdot C_{FB} \cdot (R_{FB(DYN)} \cdot R_{FB1})}$$

Equation 5

$$f_{FB1} = \frac{1}{2 \cdot \pi \cdot C_{FB1} \cdot (R_{FB1} + R_{FB(DYN)})}$$

The $R_{FB(DYN)}$ is the dynamic resistance seen by the FB pin.

The C_{FB1} capacitor fixes the OLP delay and usually C_{FB1} results in a much higher value than C_{FB} . Equation 3 can be still used to calculate the OLP delay, but C_{FB1} has to be considered instead of C_{FB} . Using the compensation network shown in option 2, in all cases the loop stability can be set as well as a sufficient OLP delay.

Figure 22. FB pin configuration (option 1)

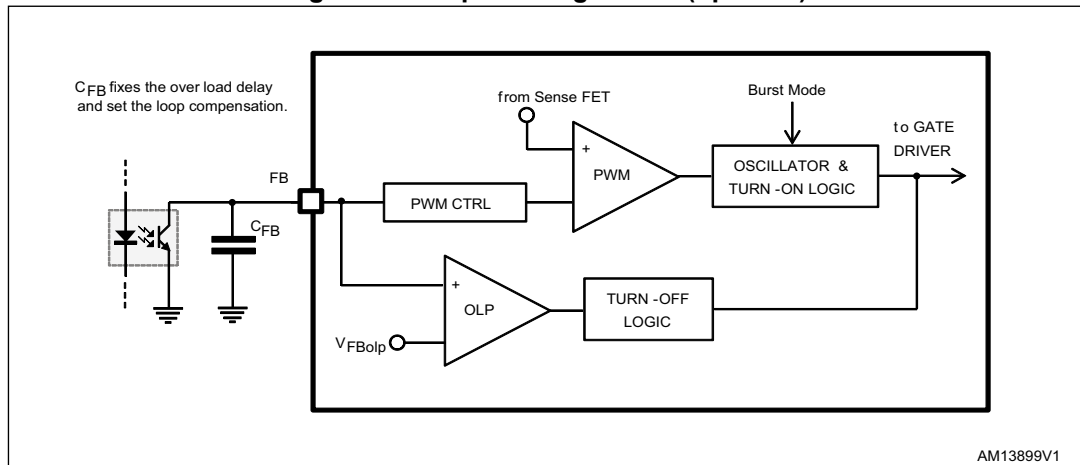
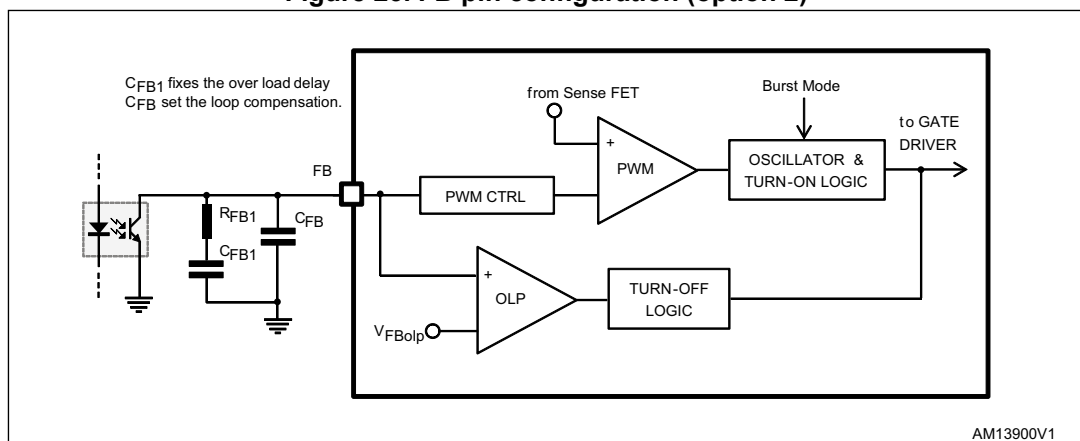

Figure 23. FB pin configuration (option 2)



7.11 Burst-mode operation at no load or very light load

When the load decreases, the feedback loop reacts by lowering the feedback pin voltage. If it falls below the burst mode threshold, V_{FBbm} , the power MOSFET is no longer allowed to be switched on. After the MOSFET stops, the feedback pin voltage increases and when it exceeds the level, $V_{FBbm} + V_{FBbmhys}$, the power MOSFET starts switching again. The burst mode thresholds are provided in [Table 8: Controller section](#) and [Figure 24: Burst mode timing diagram, light load](#) shows this behavior. The system alternates between a period of time where the power MOSFET is switching to a period of time where the power MOSFET is not switching. This mode of operation is the burst mode. The advantage of burst mode operation is an average switching frequency much lower than the normal operation frequency, up to several hundred hertz, minimizing all frequency-related losses. In order to prevent audible noise, during burst mode the drain current peak is clamped to the level, I_{D_BM} , given in [Table 8: Controller section](#).

Figure 24. Burst mode timing diagram, light load

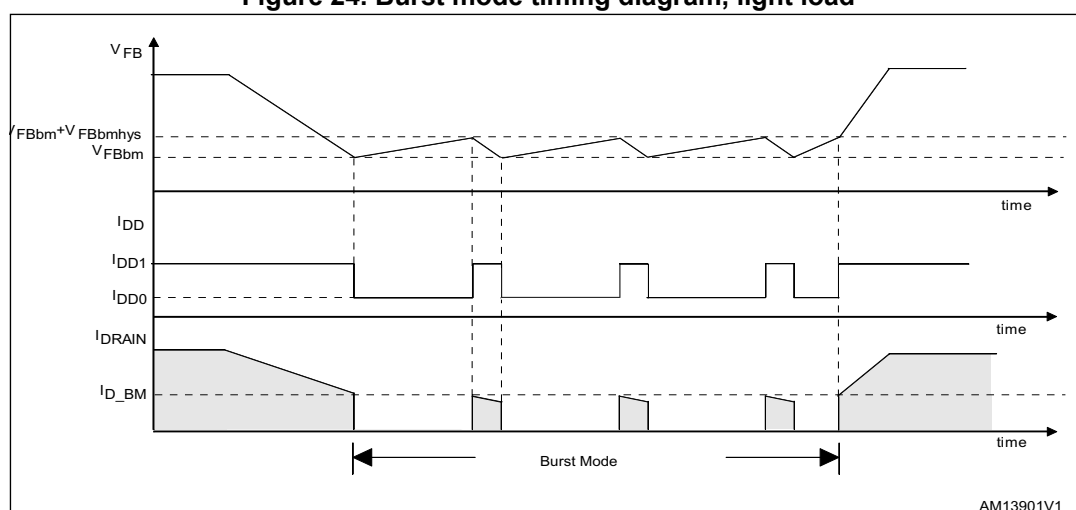

7.12 Extra power timer (EPT)

The extra power timer feature allows the setting of a blanking time inside which an overload current can be admitted. The timer is set through a capacitor (C_{EPT}) connected to the EPT pin. Its duration is in the range of a few seconds and is limited by thermal constraints.

The extra power timer (EPT) is started as soon as the drain current reaches the threshold I_{DLIM_EPT} (typ. 85% of I_{Dlim}) and its duration is defined by the time needed to charge the capacitor C_{EPT} up to the value $V_{EPT(STOP)}$ (4V, typ). The charging current is I_{EPT} (5 uA, typ).

If the EPT starts, the IC sustains the overload and continues to operate normally if the drain current falls below the threshold I_{DLIM_EPT} (85% of I_{Dlim}) before the EPT voltage reaches the value $V_{EPT(STOP)}$. The capacitor C_{EPT} is discharged through the current I_{EPT} (5 uA, typ) and the next EPT is inhibited until the EPT voltage is higher than $V_{EPT(RESTART)}$ (0.6 V, typ). If the EPT starts and the EPT voltage reaches the value $V_{EPT(STOP)}$, the IC stops and it is automatically restarted. The C_{VDD} capacitor is then discharged down to the value $V_{DD(RESTART)}$ (4.5 V, typ) and is recharged, through the HV current source, up to the value V_{DDon} (14 V, typ). Also in this case the capacitor C_{EPT} is discharged through the I_{EPT} current. See [Figure 25: EPT timing diagram](#) and [Table 7: Supply section](#). The EPT pin has

to be connected to GND if the function is not used.

Figure 25. EPT timing diagram

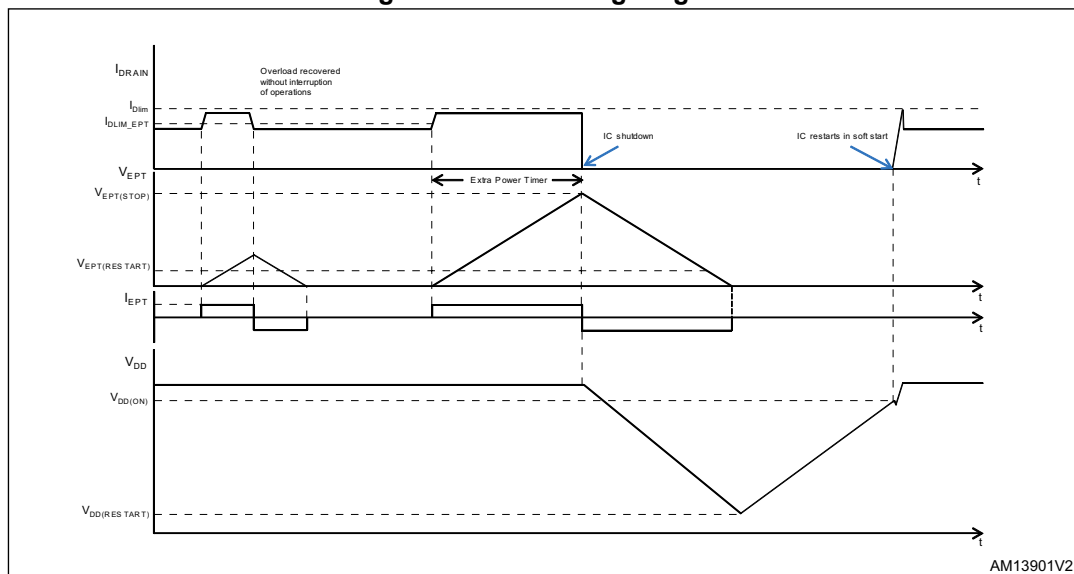

7.13 2nd level overcurrent protection and hiccup mode

The device is protected against short-circuit of the secondary rectifier, short-circuit on the secondary winding or a hard-saturation of the flyback transformer. This type of anomalous condition is invoked when the drain current exceeds the threshold I_{DMAX} , see [Table 8: Controller section](#).

To distinguish a real malfunction from a disturbance (e.g. induced during ESD tests) a "warning state" is entered after the first signal is tripped. If, in the subsequent switching cycles, the signal is not tripped, a temporary disturbance is assumed and the protection logic will be reset in its idle state; otherwise if the I_{DMAX} threshold is exceeded for two consecutive switching cycles, a real malfunction is assumed and the power MOSFET is turned OFF.

The shutdown condition is latched as long as the device is supplied. While it is disabled, no energy is transferred from the auxiliary winding, hence the voltage on the C_{VDD} capacitor decays until the V_{DD} undervoltage threshold (V_{DDoff}), which clears the latch.

The startup HV current generator is still off, until the V_{DD} voltage falls below its restart voltage, $V_{DD(RESTART)}$. After this condition the C_{VDD} capacitor is charged again by the I_{DDch2} current, and the converter switching restarts if V_{DDon} occurs. If the fault condition is not removed, the device enters auto-restart mode. This behavior results in a low-frequency intermittent operation (hiccup-mode operation), with very low stress on the power circuit.

8 Package information

In order to meet environmental requirements, ST offers these devices in different grades of ECOPACK® packages, depending on their level of environmental compliance. ECOPACK® specifications, grade definitions and product status are available at: www.st.com. ECOPACK® is an ST trademark.

8.1 SDIP10 package information

Figure 26. SDIP10 package outline

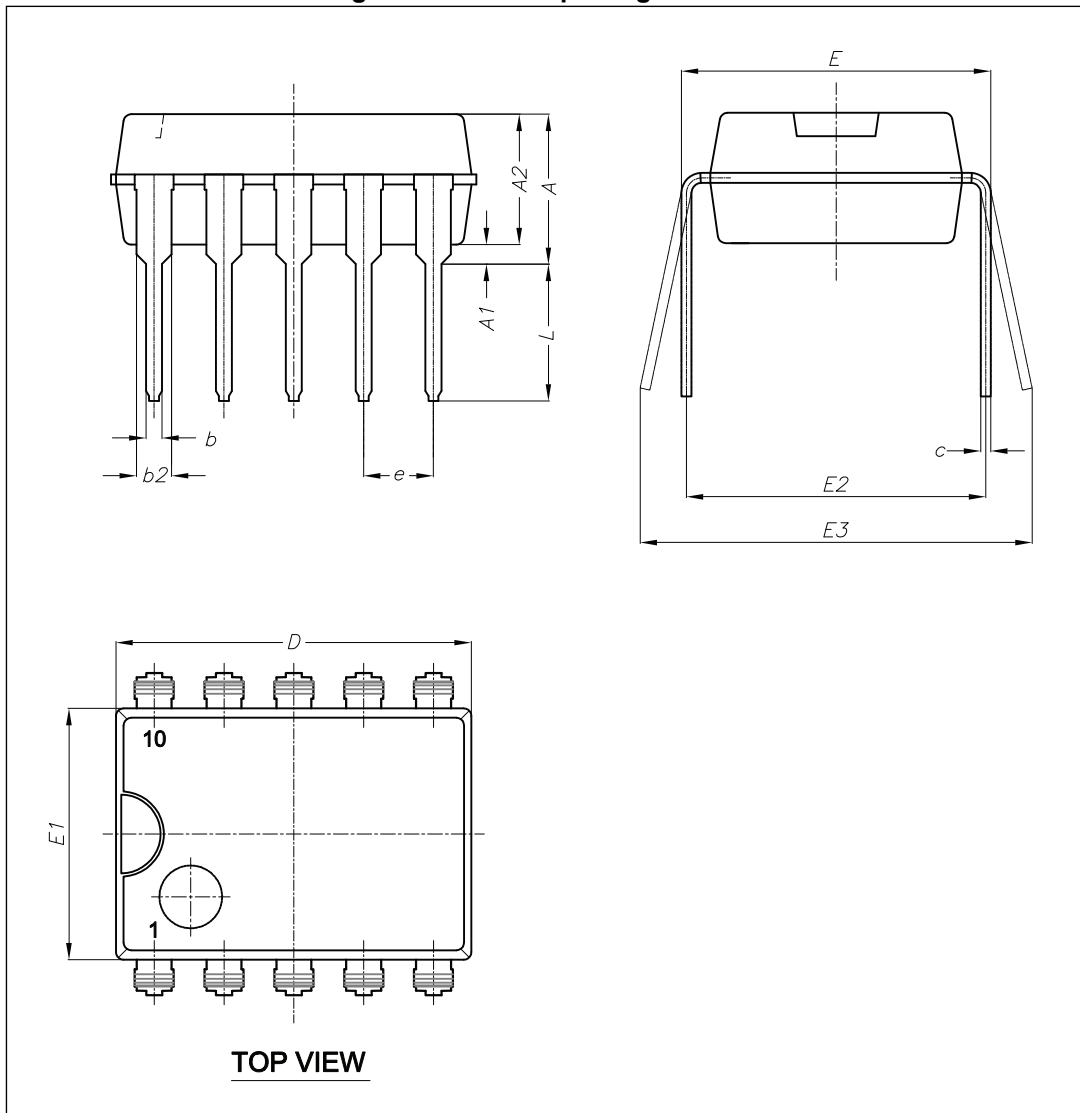

Table 10. SDIP10 mechanical data

Dim.	mm		
	Min.	Typ.	Max.
A			5.33
A1	0.38		
A2	2.92		4.95
b	0.36		0.56
b2	0.51		1.15
c	0.2		0.36
D	9.02		10.16
E	7.62		8.26
E1	6.1		7.11
E2		7.62	
E3			10.92
e		1.77	
L	2.92		3.81

8.2 SO16 Narrow package information

Figure 27. SO16 Narrow package outline

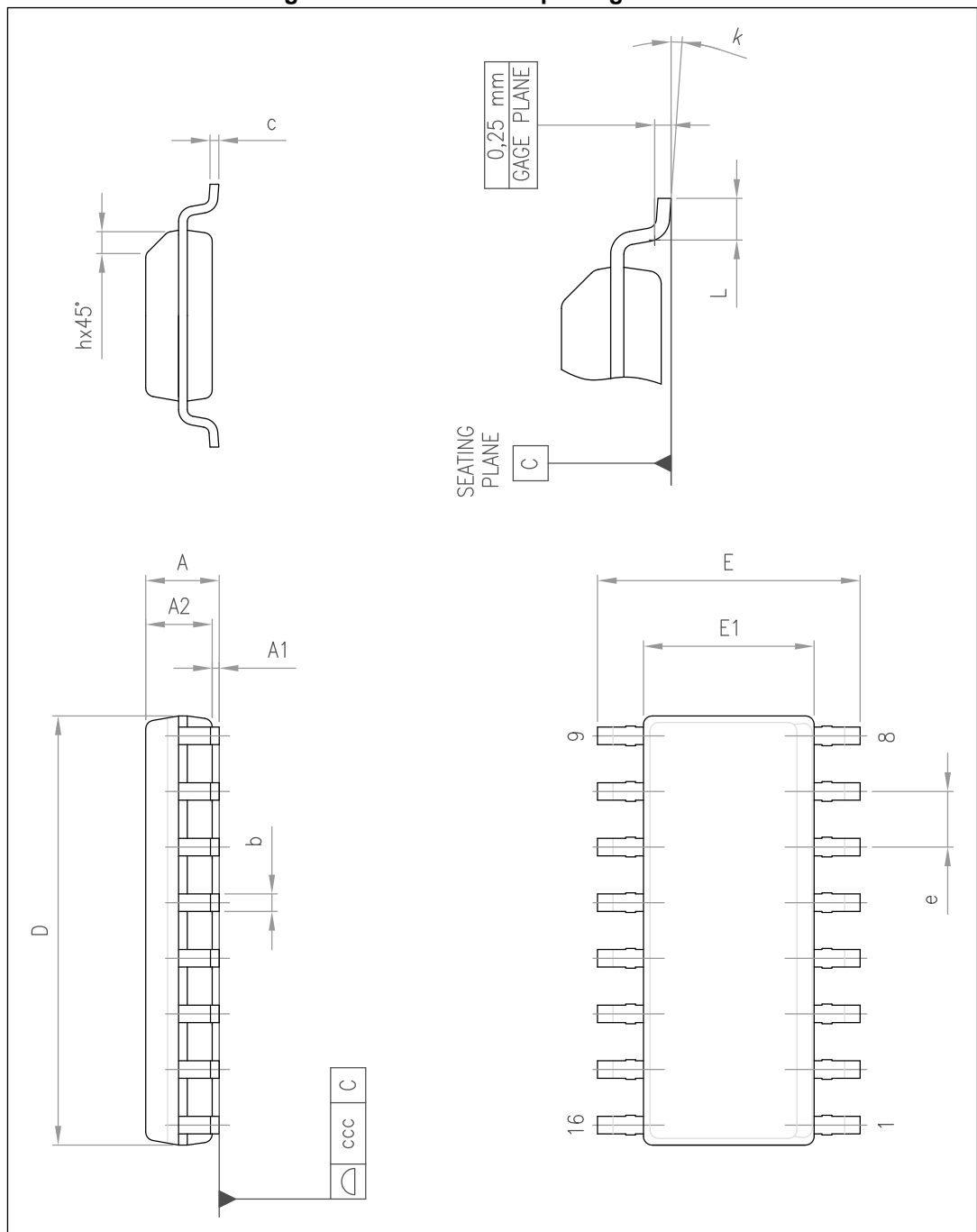

Table 11. SO16 Narrow mechanical data

Dim.	mm		
	Min.	Typ.	Max.
A			1.75
A1	0.1		0.25
A2	1.25		
b	0.31		0.51
c	0.17		0.25
D	9.8	9.9	10
E	5.8	6	6.2
E1	3.8	3.9	4
e		1.27	
h	0.25		0.5
L	0.4		1.27
k	0		8
ccc			0.1

9 Order code

Table 12. Order code

Order code	Package	Packing
VIPER38LE	SDIP10	Tube
VIPER38HE		
VIPER38HD	SO16 narrow	Tape and reel
VIPER38LD		
VIPER38HDTR		
VIPER38LDTR		

10 Revision history

Table 13. Document revision history

Date	Revision	Changes
19-Mar-2014	1	Initial release
14-Jul-2015	2	Updated title, features and description in cover page. Added SO16 narrow package. Removed Device summary table. Updated <i>Section 2: Typical power</i> , <i>Section 3: Pin settings</i> , and <i>Section 7: Operation</i> . Added <i>Section 8.2: SO16 Narrow package information</i> and <i>Section 9: Order code</i> . Minor text changes.
06-Nov-2019	3	Modified <i>Table 4: Thermal data</i> . Updated content of <i>Section 7.8: Overvoltage protection (OVP)</i>

IMPORTANT NOTICE – PLEASE READ CAREFULLY

STMicroelectronics NV and its subsidiaries ("ST") reserve the right to make changes, corrections, enhancements, modifications, and improvements to ST products and/or to this document at any time without notice. Purchasers should obtain the latest relevant information on ST products before placing orders. ST products are sold pursuant to ST's terms and conditions of sale in place at the time of order acknowledgement.

Purchasers are solely responsible for the choice, selection, and use of ST products and ST assumes no liability for application assistance or the design of Purchasers' products.

No license, express or implied, to any intellectual property right is granted by ST herein.

Resale of ST products with provisions different from the information set forth herein shall void any warranty granted by ST for such product.

ST and the ST logo are trademarks of ST. All other product or service names are the property of their respective owners.

Information in this document supersedes and replaces information previously supplied in any prior versions of this document.

© 2019 STMicroelectronics – All rights reserved

OUR CERTIFICATE

DiGi provide top-quality products and perfect service for customer worldwide through standardization, technological innovation and continuous improvement. DiGi through third-party certification, we stricly control the quality of products and services. Welcome your RFQ to

Email: Info@DiGi-Electronics.com



Tel: +00 852-30501935

RFQ Email: Info@DiGi-Electronics.com

DiGi is a global authorized distributor of electronic components.