

CDH30D14H125NP-6R8MC Datasheet



DiGi Electronics Part Number	CDH30D14H125NP-6R8MC-DG
Manufacturer	Sumida America Components Inc.
Manufacturer Product Number	CDH30D14H125NP-6R8MC
Description	FIXED IND 6.8UH 780MA 350MOHM SM
Detailed Description	6.8 μ H Unshielded Inductor 780 mA 350mOhm Non standard

<https://www.DiGi-Electronics.com>



Tel: +00 852-30501935

RFQ Email: Info@DiGi-Electronics.com

DiGi is a global authorized distributor of electronic components.

Purchase and inquiry

Manufacturer Product Number:

CDH30D14H125NP-6R8MC

Series:

CDH30D14/H125

Type:

-

Inductance:

6.8 μ H

Current Rating (Amps):

780 mA

Shielding:

Unshielded

Q @ Freq:

-

Ratings:

AEC-Q200

Inductance Frequency - Test:

100 kHz

Mounting Type:

Surface Mount

Supplier Device Package:

-

Height - Seated (Max):

0.059" (1.50mm)

Manufacturer:

Sumida America Components Inc.

Product Status:

Active

Material - Core:

Ferrite

Tolerance:

\pm 20%

Current - Saturation (Isat):

1A

DC Resistance (DCR):

350mOhm

Frequency - Self Resonant:

-

Operating Temperature:

-40°C ~ 125°C

Features:

-

Package / Case:

Nonstandard

Size / Dimension:

0.118" L x 0.118" W (3.00mm x 3.00mm)

Environmental & Export classification

RoHS Status:

RoHS Compliant

ECCN:

EAR99

Moisture Sensitivity Level (MSL):

1 (Unlimited)

HTSUS:

8504.50.8000

SMD Power Inductor

CDH30D14/H125



Description

- Ferrite drum core construction
- Magnetically unshielded
- LxWxH: 3.2x3.2x1.5 mm Max.
- Product weight: 48mg(Ref.)
- Moisture Sensitivity Level: 1
- Qualification to AEC-Q200



Environmental Data

- Operating Temperature: -40°C to +125°C (including self-heating)
- Storage temperature range: -40°C~+125°C

Packaging

- Carrier tape and reel packaging

Applications

- High temp and high reliability automotive applications

Dimension - [mm]

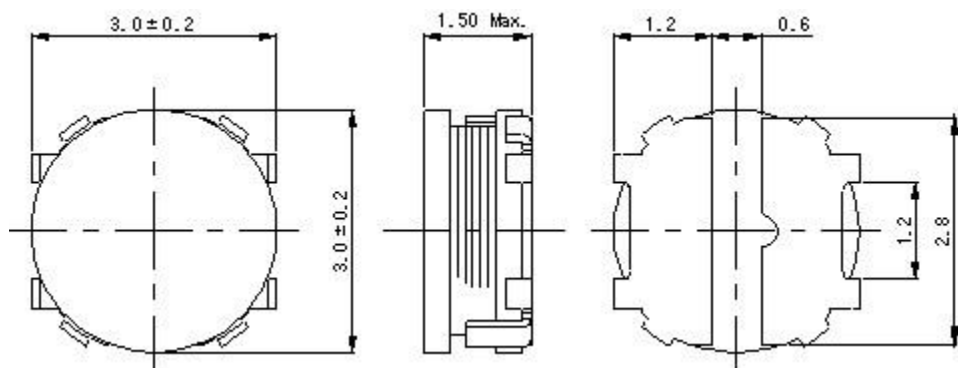

Recommended Land pattern - [mm]

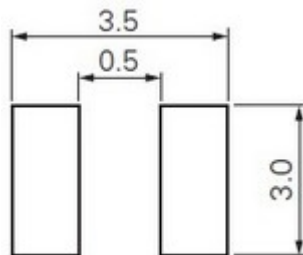

Wire Connection

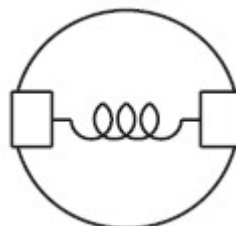

SMD Power Inductor

CDH30D14/H125



Electrical Characteristics

Part Number	Inductance [Within] (μ H) ※1	D.C.R. at 20°C Max.(Typ.) (m Ω)	Saturation Current (A) Max.(Typ.) ※2		Temperature Rise Current (A) Max.(Typ.) ※3
			20°C	125°C	
CDH30D14H125NP-1R0MC	1.00 \pm 20%	55.00 \pm 25%	2.70 (3.65)	2.20 (2.85)	1.97 (2.30)
CDH30D14H125NP-2R2MC	2.20 \pm 20%	105 \pm 25%	1.90 (2.46)	1.50 (1.93)	1.40 (1.60)
CDH30D14H125NP-3R3MC	3.30 \pm 20%	155 \pm 25%	1.50 (1.86)	1.30 (1.52)	1.12 (1.30)
CDH30D14H125NP-4R7MC	4.70 \pm 20%	200 \pm 25%	1.30 (1.64)	1.10 (1.34)	1.05 (1.20)
CDH30D14H125NP-5R6MC	5.60 \pm 20%	250 \pm 25%	1.10 (1.43)	0.95 (1.15)	0.77 (0.90)
CDH30D14H125NP-6R8MC	6.80 \pm 20%	350 \pm 25%	1.00 (1.33)	0.80 (1.07)	0.68 (0.78)
CDH30D14H125NP-100MC	10.00 \pm 20%	520 \pm 25%	0.95 (1.12)	0.70 (0.85)	0.57 (0.64)

※1 Measuring frequency inductance at 100kHz,1V.

※2 Allowable D.C. bias current: the value of D.C. current when inductance is above 70% of its initial value.

※3 Temperature rise current: the actual value of D.C. current when temperature of coil increased

$\Delta T=40^{\circ}\text{C}(T_a=20^{\circ}\text{C})$.

Solder Reflow Condition

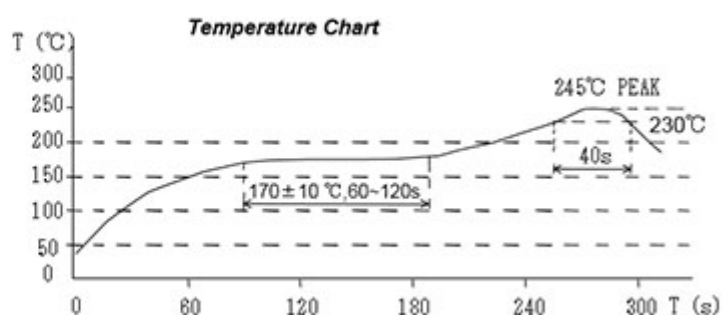
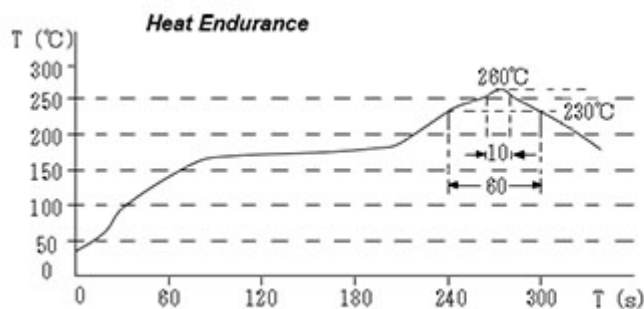

SMD Power Inductor

CDH30D14/H125



Saturation Current & Temperature Rise Graph

— L (20°C) — L (125°C) — ΔT

1. CDH30D14H125NP-1R0MC

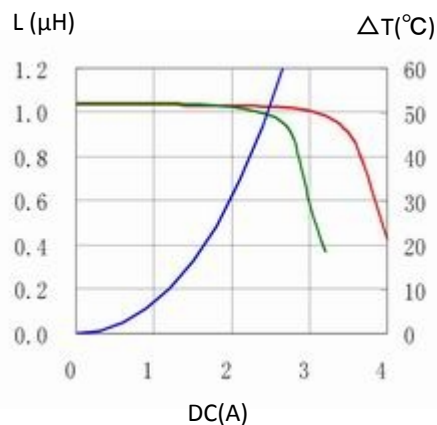

2. CDH30D14H125NP-2R2MC

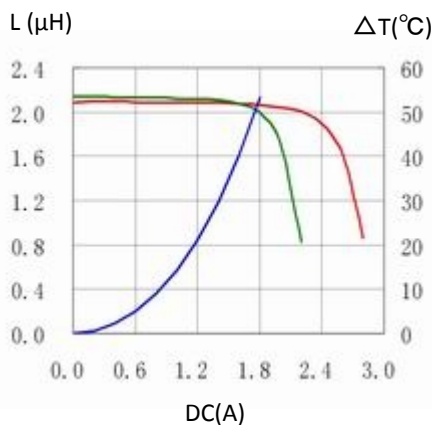

3. CDH30D14H125NP-3R3MC

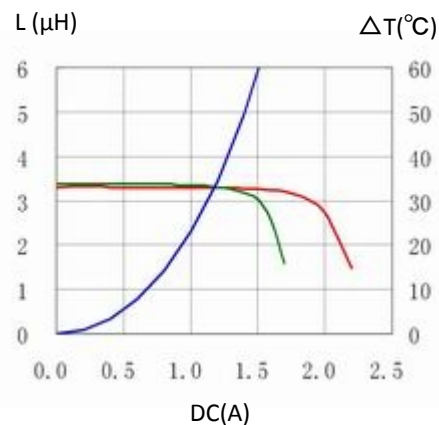

4. CDH30D14H125NP-4R7MC

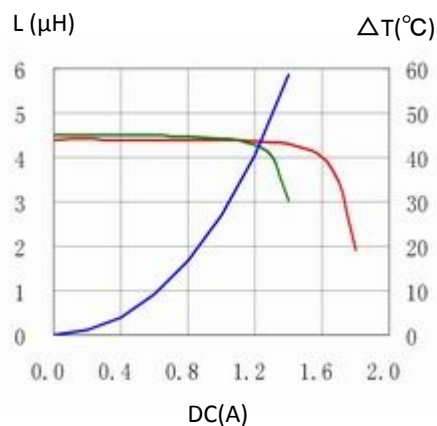

5. CDH30D14H125NP-5R6MC

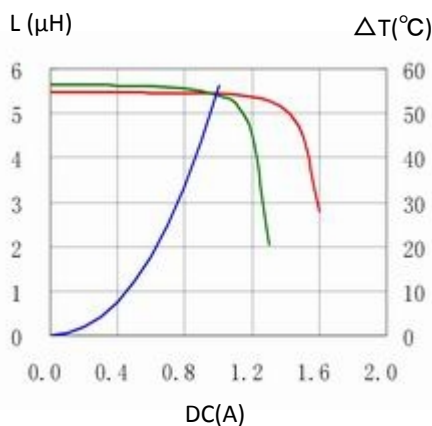

6. CDH30D14H125NP-6R8MC

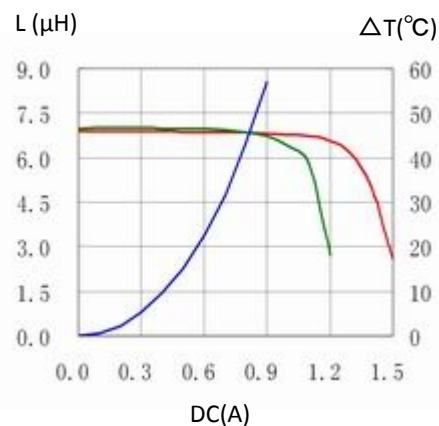

7. CDH30D14H125NP-100MC

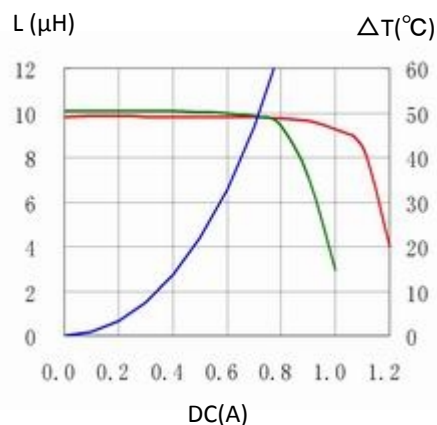

Note: This specification is subject to change without notice. Please contact your nearest sales office for updated information when placing an order.

SMD Power Inductor

CDH30D14/H125



For sales office information, please [click here](#) to visit our website.

OUR CERTIFICATE

DiGi provide top-quality products and perfect service for customer worldwide through standardization, technological innovation and continuous improvement. DiGi through third-party certification, we stricly control the quality of products and services. Welcome your RFQ to

Email: Info@DiGi-Electronics.com



Tel: +00 852-30501935

RFQ Email: Info@DiGi-Electronics.com

DiGi is a global authorized distributor of electronic components.