

B43305B5397M82 Datasheet

www.digi-electronics.com



<https://www.DiGi-Electronics.com>

DiGi Electronics Part Number	B43305B5397M82-DG
Manufacturer	EPCOS - TDK Electronics
Manufacturer Product Number	B43305B5397M82
Description	CAP ALUM 390UF 20% 450V SNAP
Detailed Description	390 μ F 450 V Aluminum Electrolytic Capacitors Radial, Can - Snap-In - 3 Lead 350mOhm @ 100Hz 2000 Hrs @ 85°C

This model B43305B5397M82 is available at DiGi Electronics.

DiGi Electronics offers a global database of semiconductor and electronic component datasheets.

We welcome your inquiries regarding pricing, lead time, or other product-related questions.

 [Request a Quote](#)

 [Datasheet Search](#)



Tel: +00 852-30501935

RFQ Email: Info@DiGi-Electronics.com

DiGi is a global authorized distributor of electronic components.

Purchase and inquiry

Manufacturer Product Number:

B43305B5397M82

Series:

B43305

Capacitance:390 μ F**Voltage - Rated:**

450 V

Lifetime @ Temp.:

2000 Hrs @ 85°C

Polarization:

Polar

Applications:

General Purpose

Impedance:

490 mOhms

Size / Dimension:

1.181" Dia (30.00mm)

Surface Mount Land Size:

-

Package / Case:

Radial, Can - Snap-In - 3 Lead

Manufacturer:

EPCOS - TDK Electronics

Product Status:

Active

Tolerance: \pm 20%**ESR (Equivalent Series Resistance):**

350mOhm @ 100Hz

Operating Temperature:

-40°C ~ 85°C

Ratings:

-

Ripple Current @ Low Frequency:

2.22 A @ 100 Hz

Lead Spacing:

0.394" (10.00mm)

Height - Seated (Max):

1.654" (42.00mm)

Mounting Type:

Through Hole

Environmental & Export classification

RoHS Status:

ROHS3 Compliant

REACH Status:

REACH Unaffected

HTSUS:

8532.22.0040

Moisture Sensitivity Level (MSL):

1 (Unlimited)

ECCN:

EAR99



Aluminum electrolytic capacitors

Snap-in capacitors

Series/Type: B43305
Date: December 2013



Snap-in capacitors

B43305

Ultra compact – 85 °C

General-purpose grade capacitors

Applications

- Frequency converters
- Solar inverters
- Uninterruptible power supplies
- Professional power supplies
- Medical appliances
- Telecommunications

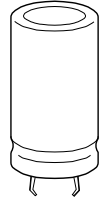

Features

- Voltage derating ($0.93 \cdot V_R$) enables 105 °C operation, more details available upon request
- Extremely high CV product, ultra compact
- High ripple current capability
- Different case sizes available for each capacitance value
- Capacitors with all insulation versions pass the needle flame test according to IEC 60695-11-5 for all flame exposure times up to 120 s
- RoHS-compatible

Construction

- Charge/discharge-proof, polar
- Aluminum case, fully insulated with PVC
- Version with PET insulation available
- Version with additional PET insulation cap on terminal side available for insulating the capacitor from the PCB
- Snap-in solder pins to hold component in place on PC-board
- Minus pole marking on case surface
- Minus pole not insulated from case
- Overload protection by safety vent on the base

Terminals

- Standard version with 2 terminals,
2 lengths available: 6.3 and 4.5 mm
- 3 terminals to ensure correct insertion: length 4.5 mm



B43305

Ultra compact – 85 °C



Specifications and characteristics in brief

Rated voltage V_R	200 ... 450 V DC										
Surge voltage V_S	$1.15 \cdot V_R$ (for $V_R \leq 250$ V DC) $1.10 \cdot V_R$ (for $V_R \geq 400$ V DC)										
Rated capacitance C_R	68 ... 3300 μ F										
Capacitance tolerance	$\pm 20\% \triangleq M$										
Dissipation factor $\tan \delta$ (20 °C, 120 Hz)	$V_R \leq 250$ V DC: $\tan \delta \leq 0.15$ $V_R \geq 400$ V DC: $\tan \delta \leq 0.20$										
Leakage current I_{leak} (5 min, 20 °C)	$I_{leak} \leq 0.3 \mu A \cdot \left(\frac{C_R}{\mu F} \cdot \frac{V_R}{V} \right)^{0.7} + 4 \mu A$										
Self-inductance ESL	Approx. 20 nH										
Useful life ¹⁾	85 °C; V_R ; $I_{AC,R}$ 40 °C; V_R ; $1.1 \cdot I_{AC,R}$	Requirements: $\Delta C/C \leq \pm 20\%$ of initial value $\tan \delta \leq 2$ times initial specified limit $I_{leak} \leq$ initial specified limit									
Voltage endurance test 85 °C; V_R	2000 h	Post test requirements: $\Delta C/C \leq \pm 10\%$ of initial value $\tan \delta \leq 1.3$ times initial specified limit $I_{leak} \leq$ initial specified limit									
Vibration resistance test	To IEC 60068-2-6, test Fc: Frequency range 10 Hz ... 55 Hz, displacement amplitude 0.35 mm, acceleration max. 5 g, duration 3 × 2 h. Capacitor mounted by its body which is rigidly clamped to the work surface.										
Characteristics at low temperature	Max. impedance ratio at 100 Hz	<table border="1"> <thead> <tr> <th>V_R</th> <th>≤ 250 V</th> <th>≥ 400 V</th> </tr> </thead> <tbody> <tr> <td>$Z_{-25^\circ C} / Z_{20^\circ C}$</td> <td>3</td> <td>7</td> </tr> <tr> <td>$Z_{-40^\circ C} / Z_{20^\circ C}$</td> <td>7</td> <td>14</td> </tr> </tbody> </table>	V_R	≤ 250 V	≥ 400 V	$Z_{-25^\circ C} / Z_{20^\circ C}$	3	7	$Z_{-40^\circ C} / Z_{20^\circ C}$	7	14
V_R	≤ 250 V	≥ 400 V									
$Z_{-25^\circ C} / Z_{20^\circ C}$	3	7									
$Z_{-40^\circ C} / Z_{20^\circ C}$	7	14									
IEC climatic category	To IEC 60068-1: <ul style="list-style-type: none"> ■ $V_R \leq 250$ V DC: 40/085/56 (–40 °C/+85 °C/56 days damp heat test) ■ $V_R \geq 400$ V DC: 25/085/56 (–25 °C/+85 °C/56 days damp heat test) The capacitors can be operated in the temperature range of –40 °C to +85 °C but the impedance at –40 °C should be taken into consideration.										
Detail specification	Similar to CECC 30301-806										
Sectional specification	IEC 60384-4										

1) Refer to chapter "General technical information, 5 Useful life" on how to interpret useful life.

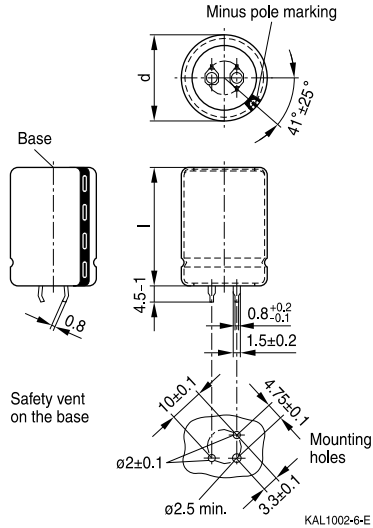
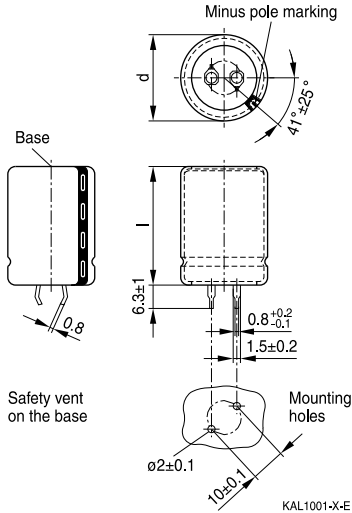
**B43305****Ultra compact – 85 °C****Dimensional drawings****Snap-in capacitors with standard insulation (PVC or PET)**

Snap-in terminals, length (6.3 ± 1) mm.
 Also available in a shorter version with a length of $(4.5 - 1)$ mm. PET insulation is marked with label "PET" on the sleeve.

Snap-in capacitors are also available with 3 terminals (length $(4.5 - 1)$ mm). PET insulation is marked with label "PET" on the sleeve.

Dimensions (mm)		Approx. weight (g)	Packing units (pcs.)
d +1	l ±2		
22	25	9	160
22	30	12	160
22	35	15	160
22	40	18	160
22	45	20	160
22	50	24	160
25	25	13	130
25	30	17	130
25	35	19	130
25	40	22	130
25	45	25	130
25	50	29	130
25	55	32	130

Dimensions (mm)		Approx. weight (g)	Packing units (pcs.)
d +1	l ±2		
30	25	17	80
30	30	23	80
30	35	29	80
30	40	36	80
30	45	41	80
30	50	46	80
30	55	53	80
35	25	22	60
35	30	29	60
35	35	36	60
35	40	41	60
35	45	56	60
35	50	70	60
35	55	81	60



B43305

Ultra compact – 85 °C



Snap-in capacitors with PVC insulation and PET insulation cap on terminal side

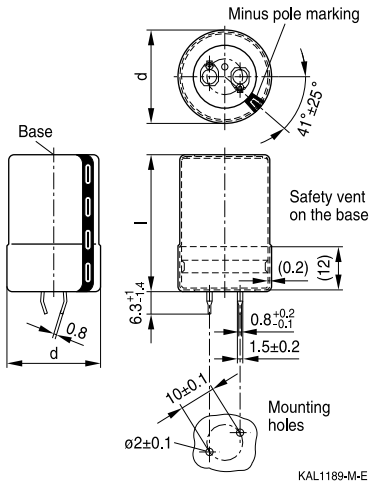

KAL1189-M-E

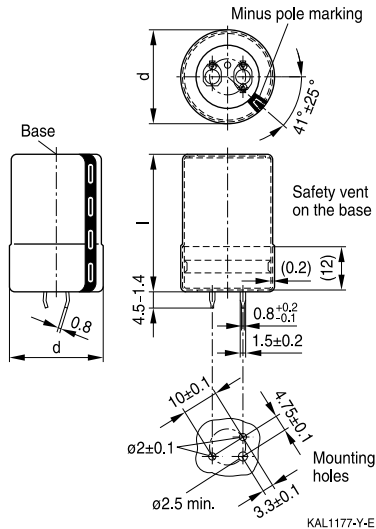

KAL1177-Y-E

Snap-in terminals, length $(6.3 +1/-1.4)$ mm. Also available in a shorter version with a length of $(4.5 -1.4)$ mm. PET insulation cap is positioned under the insulation sleeve.

Snap-in capacitors are also available with 3 terminals (length $(4.5 -1.4)$ mm). PET insulation cap is positioned under the insulation sleeve.

Dimensions (mm)		Approx. weight (g)	Packing units (pcs.)
d +1.4	l +2.2/-2		
22	25	9	160
22	30	12	160
22	35	15	160
22	40	18	160
22	45	20	160
22	50	24	160
25	25	13	115
25	30	17	115
25	35	19	115
25	40	22	115
25	45	25	115
25	50	29	115
25	55	32	115

Dimensions (mm)		Approx. weight (g)	Packing units (pcs.)
d +1.4	l +2.2/-2		
30	25	17	80
30	30	23	80
30	35	29	80
30	40	36	80
30	45	41	80
30	50	46	80
30	55	53	80
35	25	22	60
35	30	29	60
35	35	36	60
35	40	41	60
35	45	56	60
35	50	70	60
35	55	81	60

**B43305****Ultra compact – 85 °C**

Packing of snap-in capacitors



For ecological reasons the packing is pure cardboard. Components can be withdrawn (in full or in part) in the correct position for insertion.

Ordering codes for terminal styles and insulation features

Identification in 3rd block of ordering code

Snap-in capacitors

Terminal version	Insulation version		
	PVC	PET	PVC plus PET cap
Standard terminals 6.3 mm	M000	M060	M080
Short terminals 4.5 mm	M007	M067	M087
3 terminals 4.5 mm	M002	M062	M082

Ordering examples:

- B43305A9107M007 } snap-in capacitor with short terminals and standard PVC insulation
- B43305A9107M062 } snap-in capacitor with 3 terminals and PET insulation
- B43305A9107M080 } snap-in capacitor with standard terminals and PVC insulation with additional PET insulation cap on terminal side



B43305

Ultra compact – 85 °C



Overview of available types

V_R (V DC)	200	250	400	450
	Case dimensions d × l (mm)			
C_R (μF)				
68			22 × 25	22 × 25
82			22 × 25	22 × 25
100			22 × 25	22 × 25
120			22 × 25	22 × 30 25 × 25
150			22 × 30	22 × 35 25 × 30
180			22 × 30 25 × 25	22 × 40 25 × 30 30 × 25
220			22 × 35 25 × 30	22 × 45 25 × 35 30 × 30
270		22 × 25	22 × 45 25 × 35 30 × 25	22 × 50 25 × 40 30 × 30 35 × 25
330	22 × 25	22 × 30 25 × 25	22 × 50 25 × 40 30 × 30 35 × 25	25 × 50 30 × 35 35 × 30
390	22 × 25	22 × 30 25 × 25	25 × 45 30 × 35 35 × 30	25 × 55 30 × 40 35 × 30
470	22 × 30 25 × 25	22 × 35 25 × 30	25 × 50 30 × 40 35 × 30	30 × 45 35 × 35
560	22 × 35 25 × 30	22 × 40 25 × 35 30 × 25	30 × 45 35 × 35	30 × 50 35 × 40
680	22 × 40 25 × 30 30 × 25	22 × 45 25 × 40 30 × 30	30 × 50 35 × 40	35 × 45
820	22 × 45 25 × 35 30 × 30	25 × 45 30 × 35 35 × 25	30 × 55 35 × 45	35 × 55

**B43305****Ultra compact – 85 °C**

V _R (V DC)	200	250	400	450
	Case dimensions d × l (mm)			
C _R (μF)				
1000	22 × 50 25 × 40 30 × 30 35 × 25	25 × 50 30 × 35 35 × 30	35 × 50	
1200	25 × 45 30 × 35 35 × 30	25 × 55 30 × 40 35 × 35		
1500	25 × 55 30 × 40 35 × 30	30 × 50 35 × 40		
1800	30 × 45 35 × 35	30 × 55 35 × 45		
2200	30 × 55 35 × 40	35 × 50		
2700	35 × 50			
3300	35 × 55			

The capacitance and voltage ratings listed above are available in different cases upon request. Other voltage and capacitance ratings are also available upon request.



B43305

Ultra compact – 85 °C



Technical data and ordering codes

C_R 100 Hz 20 °C μF	Case dimensions $d \times l$ mm	ESR_{typ} 100 Hz 20 °C $\text{m}\Omega$	Z_{max} 10 kHz 20 °C $\text{m}\Omega$	$I_{\text{AC,max}}$ 100 Hz 60 °C A	$I_{\text{AC,R}}^{(1)}$ 100 Hz 85 °C A	Ordering code (composition see below)
$V_R = 200 \text{ V DC}$						
330	22 × 25	380	520	2.72	1.38	B43305A2337M0*#
390	22 × 25	320	440	2.95	1.50	B43305A2397M0*#
470	22 × 30	270	370	3.38	1.72	B43305A2477M0*#
470	25 × 25	270	370	3.33	1.70	B43305B2477M0*#
560	22 × 35	230	310	3.82	1.95	B43305A2567M0*#
560	25 × 30	230	310	3.79	1.93	B43305B2567M0*#
680	22 × 40	190	260	4.34	2.21	B43305A2687M0*#
680	25 × 30	190	260	4.18	2.13	B43305B2687M0*#
680	30 × 25	190	260	3.82	1.95	B43305C2687M0*#
820	22 × 45	150	210	4.90	2.50	B43305A2827M0*#
820	25 × 35	150	210	4.76	2.42	B43305B2827M0*#
820	30 × 30	150	210	4.37	2.23	B43305C2827M0*#
1000	22 × 50	130	180	5.54	2.83	B43305A2108M0*#
1000	25 × 40	130	180	5.42	2.76	B43305B2108M0*#
1000	30 × 30	130	180	4.83	2.46	B43305C2108M0*#
1000	35 × 25	130	180	4.11	2.09	B43305D2108M0*#
1200	25 × 45	110	150	6.10	3.11	B43305A2128M0*#
1200	30 × 35	110	150	5.48	2.79	B43305B2128M0*#
1200	35 × 30	110	150	4.99	2.54	B43305C2128M0*#
1500	25 × 55	85	120	7.15	3.64	B43305A2158M0*#
1500	30 × 40	85	120	6.74	3.44	B43305B2158M0*#
1500	35 × 30	85	120	5.58	2.84	B43305C2158M0*#
1800	30 × 45	70	100	7.59	3.87	B43305A2188M0*#
1800	35 × 35	70	100	6.33	3.23	B43305B2188M0*#
2200	30 × 55	60	80	8.80	4.49	B43305A2228M0*#
2200	35 × 40	60	80	7.22	3.68	B43305B2228M0*#
2700	35 × 50	45	65	8.44	4.30	B43305A2278M0*#
3300	35 × 55	40	55	9.55	4.87	B43305A2338M0*#

Composition of ordering code

* = Insulation feature

0 = PVC insulation

6 = PET insulation

8 = PVC insulation with additional PET insulation
cap on terminal side

= Terminal style

0 = snap-in standard terminals (6.3 mm)

2 = snap-in 3 terminals (4.5 mm)

7 = snap-in short terminals (4.5 mm)

1) 120-Hz conversion factor of ripple current: $I_{\text{AC}}(120 \text{ Hz}) = 1.03 \cdot I_{\text{AC}}(100 \text{ Hz})$

**B43305****Ultra compact – 85 °C****Technical data and ordering codes**

C_R 100 Hz 20 °C μF	Case dimensions $d \times l$ mm	ESR_{typ} 100 Hz 20 °C m Ω	Z_{max} 10 kHz 20 °C m Ω	$I_{\text{AC,max}}$ 100 Hz 60 °C A	$I_{\text{AC,R}^2}$ 100 Hz 85 °C A	Ordering code (composition see below)
$V_R = 250 \text{ V DC}$						
270	22 × 25	470	640	2.61	1.33	B43305E2277M0*#
330	22 × 30	380	520	3.01	1.53	B43305E2337M0*#
330	25 × 25	380	520	2.95	1.50	B43305F2337M0*#
390	22 × 30	320	440	3.27	1.67	B43305E2397M0*#
390	25 × 25	320	440	3.21	1.64	B43305F2397M0*#
470	22 × 35	270	370	3.72	1.90	B43305E2477M0*#
470	25 × 30	270	370	3.68	1.87	B43305F2477M0*#
560	22 × 40	230	310	4.19	2.13	B43305E2567M0*#
560	25 × 35	230	310	4.16	2.12	B43305F2567M0*#
560	30 × 25	230	310	3.62	1.84	B43305G2567M0*#
680	22 × 45	190	260	4.74	2.42	B43305E2687M0*#
680	25 × 40	190	260	4.73	2.41	B43305F2687M0*#
680	30 × 30	190	260	4.15	2.12	B43305G2687M0*#
820	25 × 45	150	210	5.34	2.72	B43305E2827M0*#
820	30 × 35	150	210	4.73	2.41	B43305F2827M0*#
820	35 × 25	150	210	3.82	1.95	B43305G2827M0*#
1000	25 × 50	130	180	6.04	3.08	B43305E2108M0*#
1000	30 × 35	130	180	5.22	2.66	B43305F2108M0*#
1000	35 × 30	130	180	4.69	2.39	B43305G2108M0*#
1200	25 × 55	110	150	6.77	3.45	B43305E2128M0*#
1200	30 × 40	110	150	6.29	3.21	B43305F2128M0*#
1200	35 × 35	110	150	5.32	2.71	B43305G2128M0*#
1500	30 × 50	85	120	7.41	3.78	B43305E2158M0*#
1500	35 × 40	85	120	6.13	3.13	B43305F2158M0*#
1800	30 × 55	70	100	8.31	4.24	B43305E2188M0*#
1800	35 × 45	70	100	6.91	3.52	B43305F2188M0*#
2200	35 × 50	60	80	7.83	3.99	B43305E2228M0*#

Composition of ordering code

* = Insulation feature

0 = PVC insulation

6 = PET insulation

8 = PVC insulation with additional PET insulation
cap on terminal side

= Terminal style

0 = snap-in standard terminals (6.3 mm)

2 = snap-in 3 terminals (4.5 mm)

7 = snap-in short terminals (4.5 mm)

2) 120-Hz conversion factor of ripple current: $I_{\text{AC}}(120 \text{ Hz}) = 1.03 \cdot I_{\text{AC}}(100 \text{ Hz})$



B43305

Ultra compact – 85 °C



Technical data and ordering codes

C_R 100 Hz 20 °C μF	Case dimensions $d \times l$ mm	ESR_{typ} 100 Hz 20 °C $\text{m}\Omega$	Z_{max} 10 kHz 20 °C $\text{m}\Omega$	$I_{\text{AC,max}}$ 100 Hz 60 °C A	$I_{\text{AC,R}}^{(3)}$ 100 Hz 85 °C A	Ordering code (composition see below)
$V_R = 400 \text{ V DC}$						
68	22 × 25	1990	2690	1.28	0.65	B43305A9686M0*#
82	22 × 25	1650	2230	1.41	0.72	B43305A9826M0*#
100	22 × 25	1360	1830	1.55	0.79	B43305A9107M0*#
120	22 × 25	1130	1530	1.70	0.87	B43305A9127M0*#
150	22 × 30	900	1220	1.98	1.01	B43305A9157M0*#
180	22 × 30	750	1020	2.17	1.11	B43305A9187M0*#
180	25 × 25	750	1020	2.18	1.11	B43305B9187M0*#
220	22 × 35	620	830	2.49	1.27	B43305A9227M0*#
220	25 × 30	620	830	2.51	1.28	B43305B9227M0*#
270	22 × 45	500	680	2.92	1.49	B43305A9277M0*#
270	25 × 35	500	680	2.89	1.47	B43305B9277M0*#
270	30 × 25	500	680	2.79	1.42	B43305C9277M0*#
330	22 × 50	410	560	3.31	1.69	B43305A9337M0*#
330	25 × 40	410	560	3.29	1.68	B43305B9337M0*#
330	30 × 30	410	560	3.22	1.64	B43305C9337M0*#
330	35 × 25	410	560	3.04	1.55	B43305D9337M0*#
390	25 × 45	350	470	3.68	1.87	B43305A9397M0*#
390	30 × 35	350	470	3.62	1.85	B43305B9397M0*#
390	35 × 30	350	470	3.67	1.87	B43305C9397M0*#
470	25 × 50	290	390	4.14	2.11	B43305A9477M0*#
470	30 × 40	290	390	4.37	2.23	B43305B9477M0*#
470	35 × 30	290	390	4.03	2.05	B43305C9477M0*#
560	30 × 45	240	330	4.91	2.50	B43305A9567M0*#
560	35 × 35	240	330	4.56	2.32	B43305B9567M0*#
680	30 × 50	200	270	5.55	2.83	B43305A9687M0*#
680	35 × 40	200	270	5.18	2.64	B43305B9687M0*#
820	30 × 55	170	230	6.23	3.18	B43305A9827M0*#
820	35 × 45	170	230	5.85	2.98	B43305B9827M0*#
1000	35 × 50	140	190	6.63	3.38	B43305A9108M0*#

Composition of ordering code

* = Insulation feature

0 = PVC insulation

6 = PET insulation

8 = PVC insulation with additional PET insulation
cap on terminal side

= Terminal style

0 = snap-in standard terminals (6.3 mm)

2 = snap-in 3 terminals (4.5 mm)

7 = snap-in short terminals (4.5 mm)

3) 120-Hz conversion factor of ripple current: $I_{\text{AC}}(120 \text{ Hz}) = 1.03 \cdot I_{\text{AC}}(100 \text{ Hz})$

**B43305****Ultra compact – 85 °C****Technical data and ordering codes**

C_R 100 Hz 20 °C μF	Case dimensions $d \times l$ mm	ESR_{typ} 100 Hz 20 °C m Ω	Z_{max} 10 kHz 20 °C m Ω	$I_{\text{AC,max}}$ 100 Hz 60 °C A	$I_{\text{AC,R}}^{(4)}$ 100 Hz 85 °C A	Ordering code (composition see below)
---	--	--	---	---	---	---

 $V_R = 450 \text{ V DC}$

68	22 × 25	1990	2800	1.37	0.70	B43305A5686M0*#
82	22 × 25	1650	2320	1.50	0.76	B43305A5826M0*#
100	22 × 25	1360	1900	1.66	0.85	B43305A5107M0*#
120	22 × 30	1130	1590	1.90	0.97	B43305A5127M0*#
120	25 × 25	1130	1590	1.90	0.97	B43305B5127M0*#
150	22 × 35	900	1270	2.20	1.12	B43305A5157M0*#
150	25 × 30	900	1270	2.21	1.13	B43305B5157M0*#
180	22 × 40	750	1060	2.48	1.26	B43305A5187M0*#
180	25 × 30	750	1060	2.42	1.23	B43305B5187M0*#
180	30 × 25	750	1060	2.49	1.27	B43305C5187M0*#
220	22 × 45	620	870	2.82	1.44	B43305A5227M0*#
220	25 × 35	620	870	2.78	1.41	B43305B5227M0*#
220	30 × 30	620	870	2.87	1.46	B43305C5227M0*#
270	22 × 50	500	710	3.20	1.63	B43305A5277M0*#
270	25 × 40	500	710	3.17	1.62	B43305B5277M0*#
270	30 × 30	500	710	3.18	1.62	B43305C5277M0*#
270	35 × 25	500	710	3.04	1.55	B43305D5277M0*#
330	25 × 50	410	580	3.70	1.88	B43305A5337M0*#
330	30 × 35	410	580	3.64	1.86	B43305B5337M0*#
330	35 × 30	410	580	3.73	1.90	B43305C5337M0*#
390	25 × 55	350	490	4.11	2.09	B43305A5397M0*#
390	30 × 40	350	490	4.36	2.22	B43305B5397M0*#
390	35 × 30	350	490	4.06	2.07	B43305C5397M0*#
470	30 × 45	290	410	4.92	2.51	B43305A5477M0*#
470	35 × 35	290	410	4.62	2.35	B43305B5477M0*#
560	30 × 50	240	340	5.50	2.81	B43305A5567M0*#
560	35 × 40	240	340	5.20	2.65	B43305B5567M0*#
680	35 × 45	200	280	5.89	3.00	B43305A5687M0*#
820	35 × 55	170	240	6.79	3.46	B43305A5827M0*#

Composition of ordering code

* = Insulation feature

0 = PVC insulation

6 = PET insulation

8 = PVC insulation with additional PET insulation
cap on terminal side

= Terminal style

0 = snap-in standard terminals (6.3 mm)

2 = snap-in 3 terminals (4.5 mm)

7 = snap-in short terminals (4.5 mm)

4) 120-Hz conversion factor of ripple current: $I_{\text{AC}}(120 \text{ Hz}) = 1.03 \cdot I_{\text{AC}}(100 \text{ Hz})$



B43305

Ultra compact – 85 °C



Useful life¹⁾

depending on ambient temperature T_A under ripple current operating conditions
Voltage derating ($0.93 \cdot V_R$) enables 105 °C operation

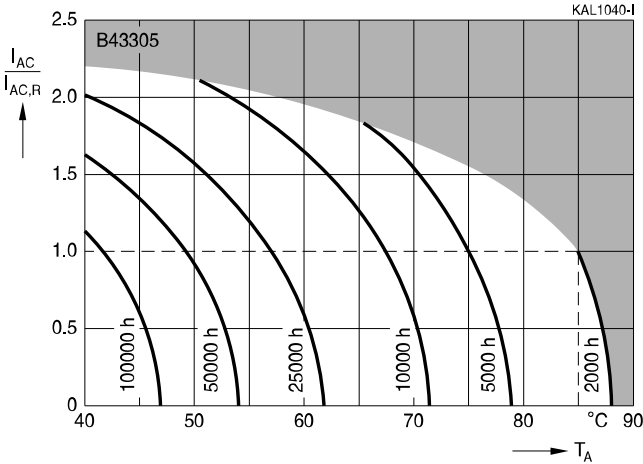

Frequency factor of permissible ripple current I_{AC} versus frequency f

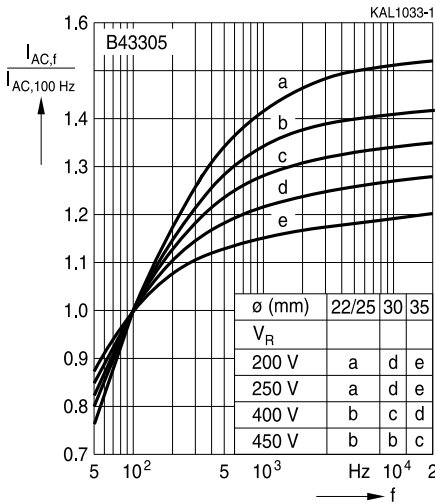

Frequency characteristics of ESR
Typical behavior

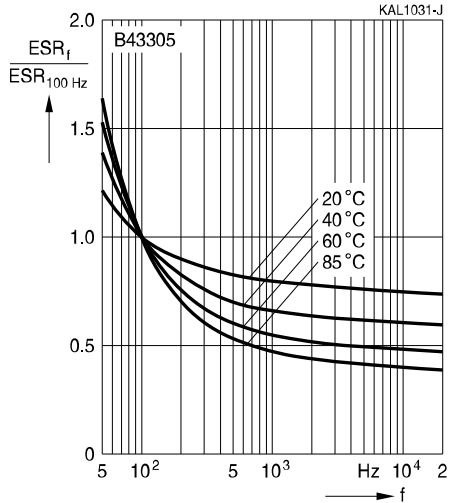

1) Refer to chapter "General technical information, 5 Useful life" on how to interpret useful life.



B43305

Ultra compact – 85 °C

Impedance Z versus frequency f

Typical behavior at 20 °C

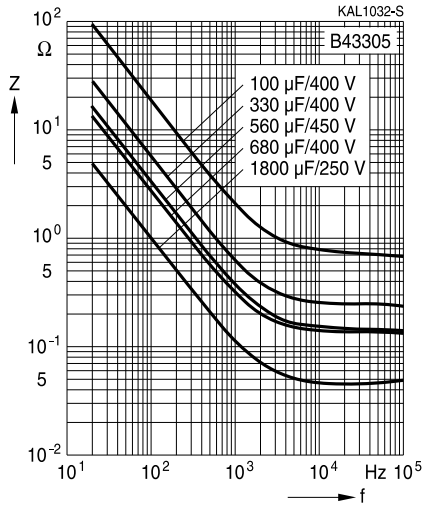



B43305

Ultra compact – 85 °C



Cautions and warnings

Personal safety

The electrolytes used by EPCOS have been optimized both with a view to the intended application and with regard to health and environmental compatibility. They do not contain any solvents that are detrimental to health, e.g. dimethyl formamide (DMF) or dimethyl acetamide (DMAC).

Furthermore, some of the high-voltage electrolytes used by EPCOS are self-extinguishing.

As far as possible, EPCOS does not use any dangerous chemicals or compounds to produce operating electrolytes. However, in exceptional cases, such materials must be used in order to achieve specific physical and electrical properties because no alternative materials are currently known. However, the amount of dangerous materials used in our products is limited to an absolute minimum.

Materials and chemicals used in EPCOS aluminum electrolytic capacitors are continuously adapted in compliance with the EPCOS Corporate Environmental Policy and the latest EU regulations and guidelines such as RoHS, REACH/SVHC, GADSL, and ELV.

MDS (Material Data Sheets) are available on the EPCOS website for all types listed in the data book. MDS for customer specific capacitors are available upon request.

MSDS (Material Safety Data Sheets) are available for all of our electrolytes upon request.

Nevertheless, the following rules should be observed when handling aluminum electrolytic capacitors: No electrolyte should come into contact with eyes or skin. If electrolyte does come into contact with the skin, wash the affected areas immediately with running water. If the eyes are affected, rinse them for 10 minutes with plenty of water. If symptoms persist, seek medical treatment. Avoid inhaling electrolyte vapor or mists. Workplaces and other affected areas should be well ventilated. Clothing that has been contaminated by electrolyte must be changed and rinsed in water.

**B43305****Ultra compact – 85 °C**

Product safety

The table below summarizes the safety instructions that must be observed without fail. A detailed description can be found in the relevant sections of chapter "General technical information".

Topic	Safety information	Reference chapter "General technical information"
Polarity	Make sure that polar capacitors are connected with the right polarity.	1 "Basic construction of aluminum electrolytic capacitors"
Reverse voltage	Voltages polarity classes should be prevented by connecting a diode.	3.1.6 "Reverse voltage"
Mounting position of screw-terminal capacitors	Do not mount the capacitor with the terminals (safety vent) upside down.	11.1. "Mounting positions of capacitors with screw terminals"
Robustness of terminals	The following maximum tightening torques must not be exceeded when connecting screw terminals: M5: 2.5 Nm M6: 4.0 Nm	11.3 "Mounting torques"
Mounting of single-ended capacitors	The internal structure of single-ended capacitors might be damaged if excessive force is applied to the lead wires. Avoid any compressive, tensile or flexural stress. Do not move the capacitor after soldering to PC board. Do not pick up the PC board by the soldered capacitor. Do not insert the capacitor on the PC board with a hole space different to the lead space specified.	11.4 "Mounting considerations for single-ended capacitors"
Soldering	Do not exceed the specified time or temperature limits during soldering.	11.5 "Soldering"
Soldering, cleaning agents	Do not allow halogenated hydrocarbons to come into contact with aluminum electrolytic capacitors.	11.6 "Cleaning agents"
Upper category temperature	Do not exceed the upper category temperature.	7.2 "Maximum permissible operating temperature"
Passive flammability	Avoid external energy, such as fire or electricity.	8.1 "Passive flammability"



B43305

Ultra compact – 85 °C



Topic	Safety information	Reference chapter "General technical information"
Active flammability	Avoid overload of the capacitors.	8.2 "Active flammability"
Maintenance	Make periodic inspections of the capacitors. Before the inspection, make sure that the power supply is turned off and carefully discharge the electricity of the capacitors. Do not apply any mechanical stress to the capacitor terminals.	10 "Maintenance"
Storage	Do not store capacitors at high temperatures or high humidity. Capacitors should be stored at +5 to +35 °C and a relative humidity of $\leq 75\%$.	7.3 Storage conditions
		Reference chapter "Capacitors with screw terminals"
Breakdown strength of insulating sleeves	Do not damage the insulating sleeve, especially when ring clips are used for mounting.	"Screw terminals – accessories"



B43305

Ultra compact – 85 °C

Symbols and terms

Symbol	English	German
C	Capacitance	Kapazität
C_R	Rated capacitance	Nennkapazität
C_S	Series capacitance	Serienkapazität
$C_{S,T}$	Series capacitance at temperature T	Serienkapazität bei Temperatur T
C_f	Capacitance at frequency f	Kapazität bei Frequenz f
d	Case diameter, nominal dimension	Gehäusedurchmesser, Nennmaß
d_{max}	Maximum case diameter	Maximaler Gehäusedurchmesser
ESL	Self-inductance	Eigeninduktivität
ESR	Equivalent series resistance	Ersatzserienwiderstand
ESR_f	Equivalent series resistance at frequency f	Ersatzserienwiderstand bei Frequenz f
ESR_T	Equivalent series resistance at temperature T	Ersatzserienwiderstand bei Temperatur T
f	Frequency	Frequenz
I	Current	Strom
I_{AC}	Alternating current (ripple current)	Wechselstrom
$I_{AC,rms}$	Root-mean-square value of alternating current	Wechselstrom, Effektivwert
$I_{AC,f}$	Ripple current at frequency f	Wechselstrom bei Frequenz f
$I_{AC,max}$	Maximum permissible ripple current	Maximal zulässiger Wechselstrom
$I_{AC,R}$	Rated ripple current	Nennwechselstrom
$I_{AC,R} (B)$	Rated ripple current for base cooling	Nennwechselstromstrom für Bodenkühlung
I_{leak}	Leakage current	Reststrom
$I_{leak,op}$	Operating leakage current	Betriebsreststrom
l	Case length, nominal dimension	Gehäuselänge, Nennmaß
l_{max}	Maximum case length (without terminals and mounting stud)	Maximale Gehäuselänge (ohne Anschlüsse und Gewindebolzen)
R	Resistance	Widerstand
R_{ins}	Insulation resistance	Isolationswiderstand
R_{symm}	Balancing resistance	Symmetrierwiderstand
T	Temperature	Temperatur
ΔT	Temperature difference	Temperaturdifferenz
T_A	Ambient temperature	Umgebungstemperatur
T_C	Case temperature	Gehäusetemperatur
T_B	Capacitor base temperature	Temperatur des Becherbodens
t	Time	Zeit
Δt	Period	Zeitraum
t_b	Service life (operating hours)	Brauchbarkeitsdauer (Betriebszeit)



B43305

Ultra compact – 85 °C



Symbol	English	German
V	Voltage	Spannung
V _F	Forming voltage	Formierspannung
V _{op}	Operating voltage	Betriebsspannung
V _R	Rated voltage, DC voltage	Nennspannung, Gleichspannung
V _S	Surge voltage	Spitzenspannung
X _C	Capacitive reactance	Kapazitiver Blindwiderstand
X _L	Inductive reactance	Induktiver Blindwiderstand
Z	Impedance	Scheinwiderstand
Z _T	Impedance at temperature T	Scheinwiderstand bei Temperatur T
tan δ	Dissipation factor	Verlustfaktor
λ	Failure rate	Ausfallrate
ε ₀	Absolute permittivity	Elektrische Feldkonstante
ε _r	Relative permittivity	Dielektrizitätszahl
ω	Angular velocity; 2 · π · f	Kreisfrequenz; 2 · π · f

Note

All dimensions are given in mm.



Important notes

The following applies to all products named in this publication:

1. Some parts of this publication contain **statements about the suitability of our products for certain areas of application**. These statements are based on our knowledge of typical requirements that are often placed on our products in the areas of application concerned. We nevertheless expressly point out **that such statements cannot be regarded as binding statements about the suitability of our products for a particular customer application**. As a rule, EPCOS is either unfamiliar with individual customer applications or less familiar with them than the customers themselves. For these reasons, it is always ultimately incumbent on the customer to check and decide whether an EPCOS product with the properties described in the product specification is suitable for use in a particular customer application.
2. We also point out that **in individual cases, a malfunction of electronic components or failure before the end of their usual service life cannot be completely ruled out in the current state of the art, even if they are operated as specified**. In customer applications requiring a very high level of operational safety and especially in customer applications in which the malfunction or failure of an electronic component could endanger human life or health (e.g. in accident prevention or lifesaving systems), it must therefore be ensured by means of suitable design of the customer application or other action taken by the customer (e.g. installation of protective circuitry or redundancy) that no injury or damage is sustained by third parties in the event of malfunction or failure of an electronic component.
3. **The warnings, cautions and product-specific notes must be observed.**
4. In order to satisfy certain technical requirements, **some of the products described in this publication may contain substances subject to restrictions in certain jurisdictions (e.g. because they are classed as hazardous)**. Useful information on this will be found in our Material Data Sheets on the Internet (www.epcos.com/material). Should you have any more detailed questions, please contact our sales offices.
5. We constantly strive to improve our products. Consequently, **the products described in this publication may change from time to time**. The same is true of the corresponding product specifications. Please check therefore to what extent product descriptions and specifications contained in this publication are still applicable before or when you place an order. We also **reserve the right to discontinue production and delivery of products**. Consequently, we cannot guarantee that all products named in this publication will always be available. The aforementioned does not apply in the case of individual agreements deviating from the foregoing for customer-specific products.
6. Unless otherwise agreed in individual contracts, **all orders are subject to the current version of the "General Terms of Delivery for Products and Services in the Electrical Industry" published by the German Electrical and Electronics Industry Association (ZVEI)**.
7. The trade names EPCOS, BAOKE, Alu-X, CeraDiode, CeraLink, CeraPlas, CSMP, CSSP, CTVS, DeltaCap, DigiSiMic, DSSP, FilterCap, FormFit, MiniBlue, MiniCell, MKD, MKK, MLSC, MotorCap, PCC, PhaseCap, PhaseCube, PhaseMod, PhiCap, SIFERRIT, SIFI, SIKOREL, SilverCap, SIMDAD, SiMic, SIMID, SineFormer, SIOV, SIP5D, SIP5K, ThermoFuse, WindCap are **trademarks registered or pending** in Europe and in other countries. Further information will be found on the Internet at www.epcos.com/trademarks.

OUR CERTIFICATE

DiGi provide top-quality products and perfect service for customer worldwide through standardization, technological innovation and continuous improvement. DiGi through third-party certification, we strictly control the quality of products and services. Welcome your RFQ to

Email: Info@DiGi-Electronics.com



Tel: +00 852-30501935

RFQ Email: Info@DiGi-Electronics.com

DiGi is a global authorized distributor of electronic components.