

B43647A5127M057 Datasheet



www.digi-electronics.com

<https://www.DiGi-Electronics.com>

DiGi Electronics Part Number	B43647A5127M057-DG
Manufacturer	EPCOS - TDK Electronics
Manufacturer Product Number	B43647A5127M057
Description	CAP ALUM 120UF 20% 450V SNAP
Detailed Description	120 μ F 450 V Aluminum Electrolytic Capacitors Radial, Can - Snap-In 880mOhm @ 100Hz 2000 Hrs @ 105°C

This model B43647A5127M057 is available at DiGi Electronics.

DiGi Electronics offers a global database of semiconductor and electronic component datasheets.

We welcome your inquiries regarding pricing, lead time, or other product-related questions.

 [Request a Quote](#)

 [Datasheet Search](#)



Tel: +00 852-30501935

RFQ Email: Info@DiGi-Electronics.com

DiGi is a global authorized distributor of electronic components.

Purchase and inquiry

Manufacturer Product Number:

B43647A5127M057

Series:

B43647

Capacitance:120 μ F**Voltage - Rated:**

450 V

Lifetime @ Temp.:

2000 Hrs @ 105°C

Polarization:

Polar

Applications:

General Purpose

Impedance:

1.32 Ohms

Size / Dimension:

0.866" Dia (22.00mm)

Surface Mount Land Size:

-

Package / Case:

Radial, Can - Snap-In

Manufacturer:

EPCOS - TDK Electronics

Product Status:

Active

Tolerance: \pm 20%**ESR (Equivalent Series Resistance):**

880mOhm @ 100Hz

Operating Temperature:

-25°C ~ 105°C

Ratings:

-

Ripple Current @ Low Frequency:

760 mA @ 100 Hz

Lead Spacing:

0.394" (10.00mm)

Height - Seated (Max):

1.063" (27.00mm)

Mounting Type:

Through Hole

Environmental & Export classification

RoHS Status:

ROHS3 Compliant

REACH Status:

REACH Unaffected

HTSUS:

8532.22.0040

Moisture Sensitivity Level (MSL):

1 (Unlimited)

ECCN:

EAR99



Aluminum electrolytic capacitors

Snap-in capacitors

Series/Type: B43647

Date: December 2019

Snap-in capacitors

B43647

Ultra compact – 105 °C**Long-life grade capacitors****Applications**

- Power supplies
- Frequency converters
- Uninterruptible power supplies
- Medical appliances
- Solar inverters
- Not for automotive applications unless otherwise specified

Features

- Extremely high CV product, ultra compact
- High reliability
- High ripple current capability
- Capacitors pass the needle flame test according to IEC 60695-11-5 for all flame exposure times up to 120 s
- RoHS-compatible

Construction

- Charge/discharge-proof, polar
- Aluminum case, insulated with PET sleeve without insulation sheet at the can bottom
- Snap-in solder pins to hold component in place on PC-board
- Minus pole marking on case surface
- Minus pole not insulated from case
- Overload protection by safety vent on the base

Terminals

- Standard version with 2 terminals,
2 lengths available: 6.3 and 4.5 mm
- 3 terminals to ensure correct insertion: length 4.5 mm

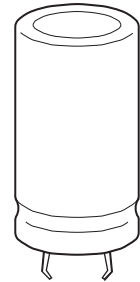

B43647

Ultra compact – 105 °C

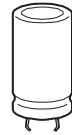

Specifications and characteristics in brief

Rated voltage V_R	450 V DC							
Surge voltage V_S	$1.10 \cdot V_R$							
Rated capacitance C_R	120 ... 1000 μF							
Capacitance tolerance	$\pm 20\% \triangleq M$							
Dissipation factor $\tan \delta$ (20 °C, 120 Hz)	$\tan \delta \leq 0.20$							
Leakage current I_{leak} (5 min, 20 °C)	$I_{\text{leak}} \leq 0.3 \mu\text{A} \cdot \left(\frac{C_R}{\mu\text{F}} \cdot \frac{V_R}{V} \right)^{0.7} + 4 \mu\text{A}$							
Self-inductance ESL	Approx. 20 nH							
Useful life ¹⁾ 105 °C; V_R ; $I_{AC,R}$	> 2000 h	Requirements: $ \Delta C/C \leq 20\%$ of initial value $\tan \delta \leq 2$ times initial specified limit $I_{\text{leak}} \leq$ initial specified limit						
Voltage endurance test 105 °C; V_R	2000 h	Post test requirements: $ \Delta C/C \leq 10\%$ of initial value $\tan \delta \leq 1.3$ times initial specified limit $I_{\text{leak}} \leq$ initial specified limit						
Vibration resistance test	To IEC 60068-2-6, test Fc: Frequency range 10 Hz ... 55 Hz, displacement amplitude 0.35 mm, acceleration max. 5 g, duration 3×2 h. Capacitor mounted by its body which is rigidly clamped to the work surface.							
Characteristics at low temperature	Max. impedance ratio at 100 Hz <table border="1" data-bbox="742 1400 1197 1541"> <tr> <td>V_R</td> <td>450 V</td> </tr> <tr> <td>$Z_{-25^\circ\text{C}} / Z_{20^\circ\text{C}}$</td> <td>5</td> </tr> <tr> <td>$Z_{-40^\circ\text{C}} / Z_{20^\circ\text{C}}$</td> <td>14</td> </tr> </table>	V_R	450 V	$Z_{-25^\circ\text{C}} / Z_{20^\circ\text{C}}$	5	$Z_{-40^\circ\text{C}} / Z_{20^\circ\text{C}}$	14	
V_R	450 V							
$Z_{-25^\circ\text{C}} / Z_{20^\circ\text{C}}$	5							
$Z_{-40^\circ\text{C}} / Z_{20^\circ\text{C}}$	14							
IEC climatic category	To IEC 60068-1: 25/105/56 (–25 °C/+105 °C/56 days damp heat test) The capacitors can be operated in the temperature range of –40 °C to +105 °C but the impedance at –40 °C must be taken into consideration.							
Sectional specification	IEC 60384-4							

1) Refer to chapter "General technical information, 5 Useful life" on how to interpret useful life.

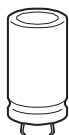

B43647

Ultra compact – 105 °C

Dimensional drawings

Snap-in capacitors with PET insulation sleeve

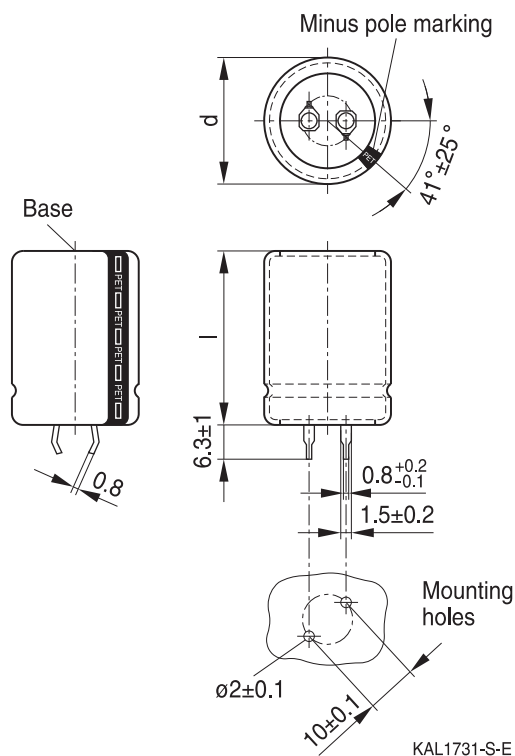

Snap-in terminals, length (6.3 ±1) mm.
 Also available in a shorter version with a length of (4.5 – 1) mm.
 Insulation is marked with "PET" on the sleeve.
 Safety vent on the base.

Dimensions (mm)		Approx. weight (g)	Packing units (pcs.)
d +1	l ±2		
22	25	9	160
22	30	12	160
22	35	15	160
22	40	18	160
22	45	20	160
25	25	13	130
25	30	17	130
25	35	19	130
25	40	22	130
25	45	25	130
25	55	32	130

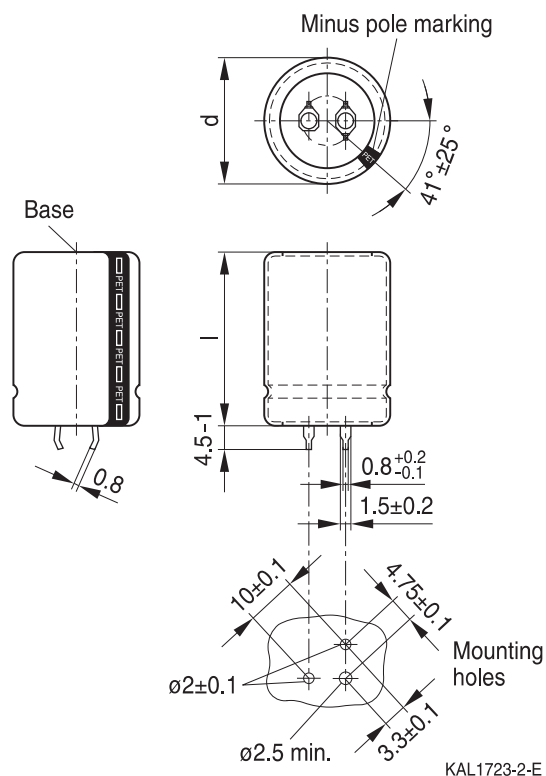

Snap-in capacitors are also available with 3 terminals (length (4.5 – 1) mm).
 Insulation is marked with "PET" on the sleeve.
 Safety vent on the base.

Dimensions (mm)		Approx. weight (g)	Packing units (pcs.)
d +1	l ±2		
30	25	17	80
30	30	23	80
30	35	29	80
30	40	36	80
30	45	41	80
30	55	53	80
Dimensions (mm)		Approx. weight (g)	Packing units (pcs.)
d +1	l +2.5/-2.0		
35	25	22	60
35	30	29	60
35	35	36	60
35	40	41	60
35	45	56	60
35	55	81	60

B43647

Ultra compact – 105 °C

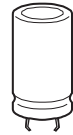

Packing of snap-in capacitors



For ecological reasons the packing is pure cardboard.

Ordering codes for terminal styles and insulation features

Identification in 3rd block of ordering code

Snap-in capacitors

Terminal version	Insulation PET sleeve
Standard terminals 6.3 mm	M050
Short terminals 4.5 mm	M057
3 terminals 4.5 mm	M052

Ordering examples:

B43647A5157M057 } snap-in capacitor with short terminals and PET sleeve
 B43647A5157M052 } snap-in capacitor with 3 terminals and PET sleeve

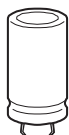
**B43647****Ultra compact – 105 °C**

Overview of available types

The capacitance and voltage ratings listed below are available in different case sizes upon request. Other voltage and capacitance ratings are also available upon request.

V_R (V DC)	450
	Case dimensions $d \times l$ (mm)
C_R (μ F)	
120	22 × 25
150	22 × 30 25 × 25
180	22 × 35
220	22 × 40 25 × 30
270	22 × 45 25 × 35 30 × 25
330	25 × 40 30 × 30 35 × 25
390	25 × 45 30 × 35
470	25 × 55 30 × 40 35 × 30
560	30 × 45 35 × 35
680	30 × 55 35 × 40
820	35 × 45
1000	35 × 55

B43647

Ultra compact – 105 °C



Technical data and ordering codes

C_R 100 Hz 20 °C μF	Case dimensions $d \times l$ mm	ESR_{typ} 100 Hz 20 °C $\text{m}\Omega$	ESR_{typ} 300 Hz 60 °C $\text{m}\Omega$	Z_{max} 10 kHz 20 °C $\text{m}\Omega$	$I_{\text{AC,max}}$ 100 Hz 60 °C A	$I_{\text{AC,max}}$ 100 Hz 85 °C A	$I_{\text{AC,R}}$ 100 Hz 105 °C A	Ordering code (composition see below)
$V_R = 450 \text{ V DC}$								
120	22 × 25	880	230	1320	1.70	1.28	0.76	B43647A5127M05#
150	22 × 30	700	180	1060	2.03	1.53	0.90	B43647A5157M05#
150	25 × 25	710	190	1070	1.94	1.46	0.86	B43647B5157M05#
180	22 × 35	590	150	880	2.37	1.78	1.05	B43647A5187M05#
220	22 × 40	480	120	720	2.80	2.11	1.24	B43647A5227M05#
220	25 × 30	490	130	740	2.62	1.97	1.16	B43647B5227M05#
270	22 × 45	390	100	590	3.33	2.51	1.48	B43647A5277M05#
270	25 × 35	400	110	600	3.09	2.33	1.37	B43647B5277M05#
270	30 × 25	420	130	640	2.82	2.12	1.25	B43647C5277M05#
330	25 × 40	330	90	500	3.66	2.75	1.62	B43647A5337M05#
330	30 × 30	340	100	520	3.30	2.49	1.47	B43647B5337M05#
330	35 × 25	350	120	540	3.06	2.31	1.36	B43647C5337M05#
390	25 × 45	280	75	420	4.22	3.18	1.87	B43647A5397M05#
390	30 × 35	280	85	440	3.78	2.85	1.68	B43647B5397M05#
470	25 × 55	230	65	350	4.97	3.74	2.21	B43647A5477M05#
470	30 × 40	240	70	360	4.40	3.32	1.80	B43647B5477M05#
470	35 × 30	250	90	390	3.91	2.95	1.60	B43647C5477M05#
560	30 × 45	200	60	310	5.07	3.82	2.08	B43647A5567M05#
560	35 × 35	210	75	330	4.52	3.40	1.85	B43647B5567M05#
680	30 × 55	160	50	250	6.02	4.53	2.46	B43647A5687M05#
680	35 × 40	180	65	270	5.24	3.95	2.15	B43647B5687M05#
820	35 × 45	150	55	230	6.06	4.56	2.48	B43647A5827M05#
1000	35 × 55	120	45	190	7.22	5.43	2.95	B43647A5108M05#

Composition of ordering code

= Terminal style

0 = snap-in standard terminals (6.3 mm)

2 = snap-in 3 terminals (4.5 mm)

7 = snap-in short terminals (4.5 mm)

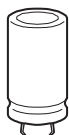

B43647

Ultra compact – 105 °C

Useful life¹⁾

For useful life calculations, please use our web-based "AlCap Useful Life Calculation Tool", which can be found on the Internet under the following link:

www.tdk-electronics.tdk.com/alcap

The AlCap Useful Life Calculation Tool provides calculations of useful life as well as additional data for selected capacitor types under operating conditions defined by the user.

In addition, it is possible to calculate useful life expectancies based on temperatures measured by the user in the application.

Frequency characteristics of ESR

Typical behavior

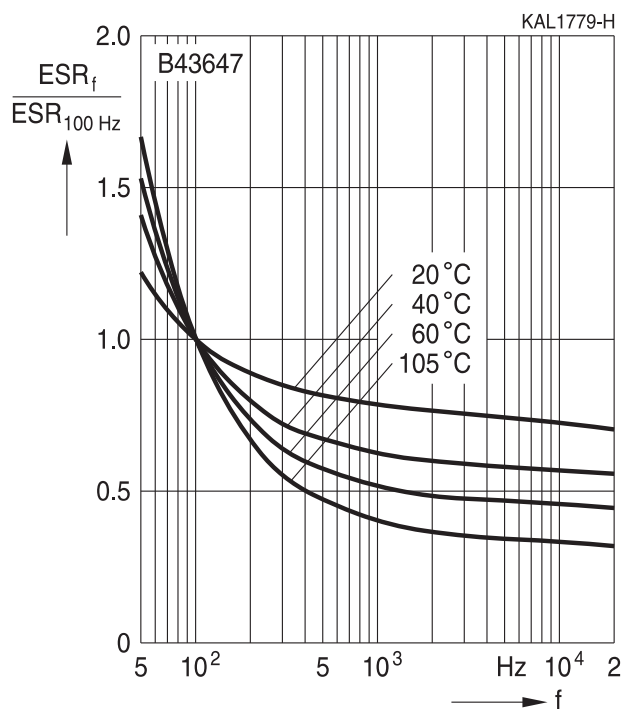

Impedance Z versus frequency f

Typical behavior at 20 °C

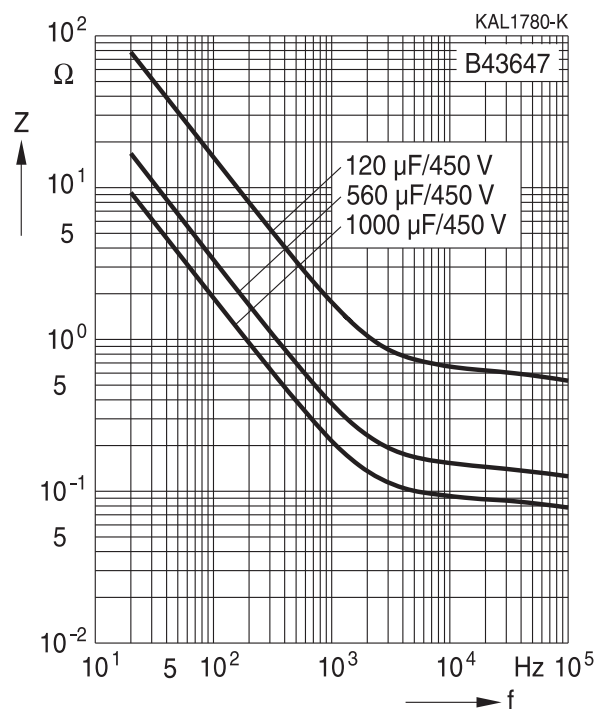

1) Refer to chapter "General technical information, 5 Useful life" on how to interpret useful life.

B43647

Ultra compact – 105 °C

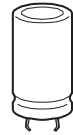

Cautions and warnings

Personal safety

The electrolytes used have been optimized both with a view to the intended application and with regard to health and environmental compatibility. They do not contain any solvents that are detrimental to health, e.g. dimethyl formamide (DMF) or dimethyl acetamide (DMAC). Furthermore, some of the high-voltage electrolytes used are self-extinguishing.

As far as possible, we do not use any dangerous chemicals or compounds to produce operating electrolytes, although in exceptional cases, such materials must be used in order to achieve specific physical and electrical properties because no alternative materials are currently known. We do, however, restrict the amount of dangerous materials used in our products to an absolute minimum.

Materials and chemicals used in our aluminum electrolytic capacitors are continuously adapted in compliance with the TDK Electronics Corporate Environmental Policy and the latest EU regulations and guidelines such as RoHS, REACH/SVHC, GADSL, and ELV.

MDS (Material Data Sheets) are available on our website for all types listed in the data book. MDS for customer specific capacitors are available upon request.

MSDS (Material Safety Data Sheets) are available for our electrolytes upon request.

Nevertheless, the following rules should be observed when handling aluminum electrolytic capacitors: No electrolyte should come into contact with eyes or skin. If electrolyte does come into contact with the skin, wash the affected areas immediately with running water. If the eyes are affected, rinse them for 10 minutes with plenty of water. If symptoms persist, seek medical treatment. Avoid inhaling electrolyte vapor or mists. Workplaces and other affected areas should be well ventilated. Clothing that has been contaminated by electrolyte must be changed and rinsed in water.

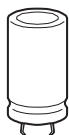

B43647

Ultra compact – 105 °C

Product safety

The table below summarizes the safety instructions that must be observed without fail. A detailed description can be found in the relevant sections of separate file chapter "General technical information".

Topic	Safety information	Reference chapter "General technical information"
Polarity	Make sure that polar capacitors are connected with the right polarity.	1 "Basic construction of aluminum electrolytic capacitors"
Reverse voltage	Voltages of opposite polarity should be prevented by connecting a diode.	3.1.6 "Reverse voltage"
Mounting position of screw-terminal capacitors	Screw terminal capacitors must not be mounted with terminals facing down unless otherwise specified.	11.1. "Mounting positions of capacitors with screw terminals"
Robustness of terminals	The following maximum tightening torques must not be exceeded when connecting screw terminals: M5: 2.5 Nm M6: 4.0 Nm	11.3 "Mounting torques"
Mounting of single-ended capacitors	The internal structure of single-ended capacitors might be damaged if excessive force is applied to the lead wires. Avoid any compressive, tensile or flexural stress. Do not move the capacitor after soldering to PC board. Do not pick up the PC board by the soldered capacitor. Do not insert the capacitor on the PC board with a hole space different to the lead space specified.	11.4 "Mounting considerations for single-ended capacitors"
Soldering	Do not exceed the specified time or temperature limits during soldering.	11.5 "Soldering"
Soldering, cleaning agents	Do not allow halogenated hydrocarbons to come into contact with aluminum electrolytic capacitors.	11.6 "Cleaning agents"
Upper category temperature	Do not exceed the upper category temperature.	7.2 "Maximum permissible operating temperature"
Passive flammability	Avoid external energy, e.g. fire.	8.1 "Passive flammability"

B43647

Ultra compact – 105 °C



Topic	Safety information	Reference chapter "General technical information"
Active flammability	Avoid overload of the capacitors.	8.2 "Active flammability"
Maintenance	Make periodic inspections of the capacitors. Before the inspection, make sure that the power supply is turned off and carefully discharge the capacitors. Do not apply excessive mechanical stress to the capacitor terminals when mounting.	10 "Maintenance"
Storage	Do not store capacitors at high temperatures or high humidity. Capacitors should be stored at +5 to +35 °C and a relative humidity of ≤ 75%.	7.3 "Shelf life and storage conditions"
		Reference chapter "Capacitors with screw terminals"
Breakdown strength of insulating sleeves	Do not damage the insulating sleeve, especially when ring clips are used for mounting.	"Screw terminals – accessories"

Display of ordering codes for TDK Electronics products

The ordering code for one and the same product can be represented differently in data sheets, data books, other publications, on the company website, or in order-related documents such as shipping notes, order confirmations and product labels. The varying representations of the ordering codes are due to different processes employed and do not affect the specifications of the respective products.

Detailed information can be found on the Internet under www.tdk-electronics.tdk.com/orderingcodes.

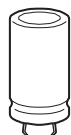

B43647

Ultra compact – 105 °C

Symbols and terms

Symbol	English	German
C	Capacitance	Kapazität
C_R	Rated capacitance	Nennkapazität
C_S	Series capacitance	Serienkapazität
$C_{S,T}$	Series capacitance at temperature T	Serienkapazität bei Temperatur T
C_f	Capacitance at frequency f	Kapazität bei Frequenz f
d	Case diameter, nominal dimension	Gehäusedurchmesser, Nennmaß
d_{max}	Maximum case diameter	Maximaler Gehäusedurchmesser
ESL	Self-inductance	Eigeninduktivität
ESR	Equivalent series resistance	Ersatzserienwiderstand
ESR_f	Equivalent series resistance at frequency f	Ersatzserienwiderstand bei Frequenz f
ESR_T	Equivalent series resistance at temperature T	Ersatzserienwiderstand bei Temperatur T
f	Frequency	Frequenz
I	Current	Strom
I_{AC}	Alternating current (ripple current)	Wechselstrom
$I_{AC,RMS}$	Root-mean-square value of alternating current	Wechselstrom, Effektivwert
$I_{AC,f}$	Ripple current at frequency f	Wechselstrom bei Frequenz f
$I_{AC,max}$	Maximum permissible ripple current	Maximal zulässiger Wechselstrom
$I_{AC,R}$	Rated ripple current	Nennwechselstrom
I_{leak}	Leakage current	Reststrom
$I_{leak,op}$	Operating leakage current	Betriebsreststrom
l	Case length, nominal dimension	Gehäuselänge, Nennmaß
l_{max}	Maximum case length (without terminals and mounting stud)	Maximale Gehäuselänge (ohne Anschlüsse und Gewindebolzen)
R	Resistance	Widerstand
R_{ins}	Insulation resistance	Isolationswiderstand
R_{symm}	Balancing resistance	Symmetrierwiderstand
T	Temperature	Temperatur
ΔT	Temperature difference	Temperaturdifferenz
T_A	Ambient temperature	Umgebungstemperatur
T_C	Case temperature	Gehäusetemperatur
T_B	Capacitor base temperature	Temperatur des Gehäusebodens
t	Time	Zeit
Δt	Period	Zeitraum
t_b	Service life (operating hours)	Brauchbarkeitsdauer (Betriebszeit)

B43647

Ultra compact – 105 °C



Symbol	English	German
V	Voltage	Spannung
V_F	Forming voltage	Formierspannung
V_{op}	Operating voltage	Betriebsspannung
V_R	Rated voltage, DC voltage	Nennspannung, Gleichspannung
V_S	Surge voltage	Spitzenspannung
X_C	Capacitive reactance	Kapazitiver Blindwiderstand
X_L	Inductive reactance	Induktiver Blindwiderstand
Z	Impedance	Scheinwiderstand
Z_T	Impedance at temperature T	Scheinwiderstand bei Temperatur T
$\tan \delta$	Dissipation factor	Verlustfaktor
λ	Failure rate	Ausfallrate
ϵ_0	Absolute permittivity	Elektrische Feldkonstante
ϵ_r	Relative permittivity	Dielektrizitätszahl
ω	Angular velocity; $2 \cdot \pi \cdot f$	Kreisfrequenz; $2 \cdot \pi \cdot f$

Note

All dimensions are given in mm.

Important notes

The following applies to all products named in this publication:

1. Some parts of this publication contain **statements about the suitability of our products for certain areas of application**. These statements are based on our knowledge of typical requirements that are often placed on our products in the areas of application concerned. We nevertheless expressly point out **that such statements cannot be regarded as binding statements about the suitability of our products for a particular customer application**. As a rule, we are either unfamiliar with individual customer applications or less familiar with them than the customers themselves. For these reasons, it is always ultimately incumbent on the customer to check and decide whether a product with the properties described in the product specification is suitable for use in a particular customer application.
2. We also point out that **in individual cases, a malfunction of electronic components or failure before the end of their usual service life cannot be completely ruled out in the current state of the art, even if they are operated as specified**. In customer applications requiring a very high level of operational safety and especially in customer applications in which the malfunction or failure of an electronic component could endanger human life or health (e.g. in accident prevention or lifesaving systems), it must therefore be ensured by means of suitable design of the customer application or other action taken by the customer (e.g. installation of protective circuitry or redundancy) that no injury or damage is sustained by third parties in the event of malfunction or failure of an electronic component.
3. **The warnings, cautions and product-specific notes must be observed.**
4. In order to satisfy certain technical requirements, **some of the products described in this publication may contain substances subject to restrictions in certain jurisdictions (e.g. because they are classed as hazardous)**. Useful information on this will be found in our Material Data Sheets on the Internet (www.tdk-electronics.tdk.com/material). Should you have any more detailed questions, please contact our sales offices.
5. We constantly strive to improve our products. Consequently, **the products described in this publication may change from time to time**. The same is true of the corresponding product specifications. Please check therefore to what extent product descriptions and specifications contained in this publication are still applicable before or when you place an order. We also **reserve the right to discontinue production and delivery of products**. Consequently, we cannot guarantee that all products named in this publication will always be available. The aforementioned does not apply in the case of individual agreements deviating from the foregoing for customer-specific products.
6. Unless otherwise agreed in individual contracts, **all orders are subject to our General Terms and Conditions of Supply**.

Important notes

7. **Our manufacturing sites serving the automotive business apply the IATF 16949 standard.** The IATF certifications confirm our compliance with requirements regarding the quality management system in the automotive industry. Referring to customer requirements and customer specific requirements (“CSR”) TDK always has and will continue to have the policy of respecting individual agreements. Even if IATF 16949 may appear to support the acceptance of unilateral requirements, we hereby like to emphasize that **only requirements mutually agreed upon can and will be implemented in our Quality Management System.** For clarification purposes we like to point out that obligations from IATF 16949 shall only become legally binding if individually agreed upon.
8. The trade names EPCOS, CeraCharge, CeraDiode, CeraLink, CeraPad, CeraPlas, CSMP, CTVS, DeltaCap, DigiSiMic, ExoCore, FilterCap, FormFit, LeaXield, MiniBlue, MiniCell, MKD, MKK, MotorCap, PCC, PhaseCap, PhaseCube, PhaseMod, PhiCap, PowerHap, PQSine, PQvar, SIFERRIT, SIFI, SIKOREL, SilverCap, SIMDAD, SiMic, SIMID, SineFormer, SIOV, ThermoFuse, WindCap are **trademarks registered or pending** in Europe and in other countries. Further information will be found on the Internet at www.tdk-electronics.tdk.com/trademarks.

Release 2018-10

OUR CERTIFICATE

DiGi provide top-quality products and perfect service for customer worldwide through standardization, technological innovation and continuous improvement. DiGi through third-party certification, we stricly control the quality of products and services. Welcome your RFQ to

Email: Info@DiGi-Electronics.com



Tel: +00 852-30501935

RFQ Email: Info@DiGi-Electronics.com

DiGi is a global authorized distributor of electronic components.