

CSD96370Q5M Datasheet

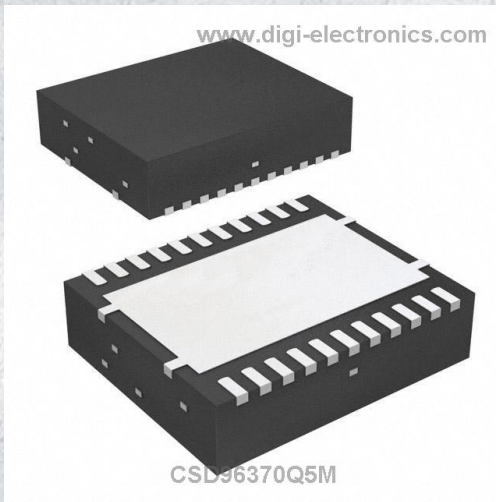

<https://www.DiGi-Electronics.com>

| | |
|------------------------------|--|
| DiGi Electronics Part Number | CSD96370Q5M-DG |
| Manufacturer | Texas Instruments |
| Manufacturer Product Number | CSD96370Q5M |
| Description | IC HALF BRIDGE DRIVER 40A 22LSON |
| Detailed Description | Half Bridge Driver Synchronous Buck Converters Power MOSFET 22-LSON-CLIP (6x5) |



Tel: +00 852-30501935

RFQ Email: Info@DiGi-Electronics.com

DiGi is a global authorized distributor of electronic components.

Purchase and inquiry

Manufacturer Product Number:

CSD96370Q5M

Series:

NexFET™

Output Configuration:

Half Bridge

Interface:

PWM

Technology:

Power MOSFET

Current - Output / Channel:

40A

Voltage - Supply:

4.5V ~ 5.5V

Operating Temperature:

-40°C ~ 150°C (Tj)

Fault Protection:

Shoot-Through, UVLO

Package / Case:

22-PowerLDFDN

Base Product Number:

CSD96370

Manufacturer:

Texas Instruments

Product Status:

Active

Applications:

Synchronous Buck Converters

Load Type:

Inductive

Rds On (Typ):

-

Current - Peak Output:

60A

Voltage - Load:

3.3V ~ 13.2V

Features:

Bootstrap Circuit

Mounting Type:

Surface Mount

Supplier Device Package:

22-LSON-CLIP (6x5)

Environmental & Export classification

RoHS Status:

ROHS3 Compliant

REACH Status:

REACH Unaffected

HTSUS:

8542.39.0001

Moisture Sensitivity Level (MSL):

2 (1 Year)

ECCN:

EAR99

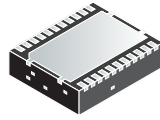

Synchronous Buck NexFET™ Power Stage

FEATURES

- 90% System Efficiency at 25A
- High Frequency Operation (Up To 2MHz)
- Incorporates Power Block Technology
- High Density – SON 5-mm × 6-mm Footprint
- Low Power Loss 2.6W at 25A
- Ultra Low Inductance Package
- System Optimized PCB Footprint
- 3.3V and 5V PWM Signal Compatible
- 3-State PWM Input
- Integrated Bootstrap Diode
- Pre-Bias Start-Up Protection
- Shoot Through Protection
- RoHS Compliant – Lead Free Terminal Plating
Halogen Free

APPLICATIONS

- Synchronous Buck Converters
- Multiphase Synchronous Buck Converters
- POL DC-DC Converters
- Memory and Graphic Cards
- Desktop and Server VR11.x and VR12 V-Core Synchronous Buck Converters

ORDERING INFORMATION

| Device | Package | Media | Qty | Ship |
|-------------|---------------------------------|--------------|------|---------------|
| CSD96370Q5M | SON 5-mm × 6-mm Plastic Package | 13-Inch Reel | 2500 | Tape and Reel |

DESCRIPTION

The CSD96370Q5M NexFET Power Stage is an optimized design for use in a high power, high density Synchronous Buck converter. This product integrates an enhanced gate driver IC and Power Block Technology to complete the power stage switching function. This combination produces a high current, high efficiency, high speed switching device and delivers an excellent thermal solution in a small 5-mm × 6-mm outline package due to its large ground based thermal pad. In addition, the PCB footprint has been optimized to help reduce design time and simplify the completion of the overall system design.

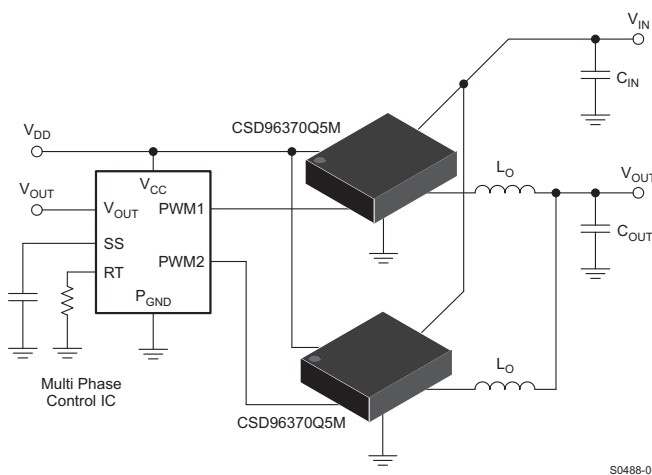

Figure 1. Application Diagram

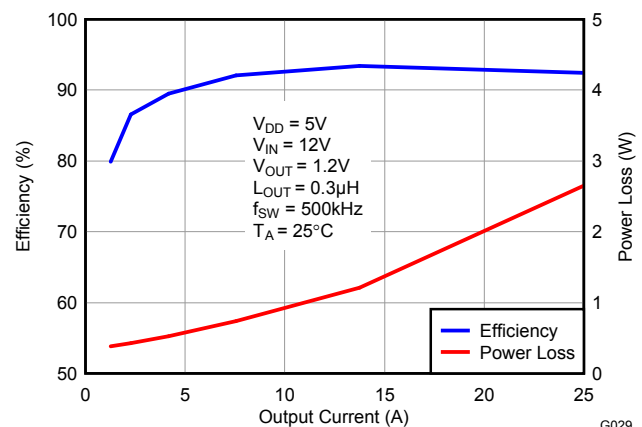

Figure 2. Efficiency and Power Loss



Please be aware that an important notice concerning availability, standard warranty, and use in critical applications of Texas Instruments semiconductor products and disclaimers thereto appears at the end of this data sheet.

CSD96370Q5M

SLPS265C – NOVEMBER 2010 – REVISED OCTOBER 2011

www.ti.com



These devices have limited built-in ESD protection. The leads should be shorted together or the device placed in conductive foam during storage or handling to prevent electrostatic damage to the MOS gates.

ABSOLUTE MAXIMUM RATINGS⁽¹⁾

$T_A = 25^\circ\text{C}$ (unless otherwise noted)

| | VALUE | UNIT |
|--------------------------------------|----------------------------|------------------|
| V_{IN} to P_{GND} ⁽²⁾ | -0.3 to 16 | V |
| V_{DD} to P_{GND} | -0.3 to 6 | V |
| V_{sw} to P_{GND} | -0.3 to 25 | V |
| V_{sw} to P_{GND} (10ns) | -7 to 27 | V |
| ENABLE to P_{GND} ⁽³⁾ | -0.3 to $V_{DD} + 0.3$ | V |
| PWM to P_{GND} ⁽³⁾ | -0.3 to $V_{DD} + 0.3$ | V |
| BOOT to BOOT_R ⁽³⁾ | -0.3 to $V_{DD} + 0.3$ | V |
| ESD Rating | Human Body Model (HBM) | 2 |
| | Charged Device Model (CDM) | 500 |
| Power Dissipation, P_D | 12 | W |
| Storage Temperature Range, T_{STG} | -55 to 150 | $^\circ\text{C}$ |
| Operating Junction Temperature Range | -40 to 150 | $^\circ\text{C}$ |

(1) Stresses above those listed in "Absolute Maximum Ratings" may cause permanent damage to the device. These are stress ratings only and functional operation of the device at these or any other conditions beyond those indicated under "Recommended Operating Conditions" is not implied. Exposure to Absolute Maximum rated conditions for extended periods may affect device reliability.

(2) V_{IN} to V_{sw} Max = 27V for 10ns

(3) Should not exceed 6V

RECOMMENDED OPERATING CONDITIONS

$T_A = 25^\circ$ (unless otherwise noted)

| Parameter | Conditions | MIN | MAX | UNIT |
|--|--|-----|------|------------------|
| Gate Drive Voltage, V_{DD} | | 4.5 | 5.5 | V |
| Input Supply Voltage, V_{IN} | | 3.3 | 13.2 | V |
| Output Voltage, V_{OUT} | | | 5.5 | V |
| Continuous Output Current, I_{OUT} | $V_{IN} = 12\text{V}$, $V_{DD} = 5\text{V}$, $V_{OUT} = 1.2\text{V}$, $f_{sw} = 500\text{kHz}$, $L_{OUT} = 0.3\mu\text{H}$ ⁽¹⁾ | | 40 | A |
| Peak Output Current, I_{OUT-PK} ⁽²⁾ | | | 60 | A |
| Switching Frequency, f_{sw} | $C_{BST} = 0.1\mu\text{F}$ (min) | 200 | 2000 | kHz |
| On Time Duty Cycle | | | 85% | |
| Minimum PWM On Time | | 40 | | ns |
| Operating Temperature | | -40 | 125 | $^\circ\text{C}$ |

(1) Measurement made with six 10- μF (TDK C3216X5R1C106KT or equivalent) ceramic capacitors placed across V_{IN} to P_{GND} pins.

(2) System conditions as defined in Note 1. Peak Output Current is applied for $t_p = 50\mu\text{s}$.

THERMAL INFORMATION

$T_A = 25^\circ\text{C}$ (unless otherwise noted)

| PARAMETER | | MIN | TYP | MAX | UNIT |
|-----------------|--|-----|-----|-----|---------------------------|
| $R_{\theta JC}$ | Thermal Resistance, Junction-to-Case (Top of package) ⁽¹⁾ | | | 20 | $^\circ\text{C}/\text{W}$ |
| $R_{\theta JB}$ | Thermal Resistance, Junction-to-Board ⁽²⁾ | | | 2 | $^\circ\text{C}/\text{W}$ |

(1) $R_{\theta JC}$ is determined with the device mounted on a 1-inch² (6.45-cm²), 2 oz. (0.071-mm thick) Cu pad on a 1.5-inch \times 1.5-inch, 0.06-inch (1.52-mm) thick FR4 board.

(2) $R_{\theta JB}$ value based on hottest board temperature within 1mm of the package.

ELECTRICAL CHARACTERISTICST_A = 25°C, V_{DD} = POR to 5.5V (unless otherwise noted)

| PARAMETER | CONDITIONS | MIN | TYP | MAX | UNIT |
|---|--|-----|------|------|------|
| P_{Loss} | | | | | |
| Power Loss ⁽¹⁾ | V _{IN} = 12V, V _{DD} = 5V, V _{OUT} = 1.2V, I _{OUT} = 25A, f _{SW} = 500kHz, L _{OUT} = 0.3μH, T _J = 25°C | – | 2.6 | 3.3 | W |
| Power Loss ⁽²⁾ | V _{IN} = 12V, V _{DD} = 5V, V _{OUT} = 1.2V, I _{OUT} = 40A, f _{SW} = 500kHz, L _{OUT} = 0.3μH, T _J = 125°C | – | 8 | 10 | W |
| V_{IN} | | | | | |
| V _{IN} Quiescent Current (I _Q) | ENABLE = 0V, V _{DD} = 5V | – | – | 100 | μA |
| V_{DD} | | | | | |
| Standby Supply Current (I _{DD}) | ENABLE = 0V, PWM = 0V | – | 1 | 5 | μA |
| Operating Supply Current (I _{DD}) | ENABLE = 5V, PWM = 50% Duty cycle, f _{SW} = 500kHz | – | 16 | 20 | mA |
| POWER-ON RESET AND UNDER VOLTAGE LOCKOUT | | | | | |
| Power on Reset (V _{DD} Rising) | | – | 3.6 | 3.9 | V |
| UVLO (V _{DD} Falling) | | 3.4 | 3.5 | – | V |
| Hysteresis | | 100 | – | 250 | mV |
| Startup Delay ⁽³⁾ | ENABLE = PWM = 5V | – | 600 | 1000 | ns |
| ENABLE | | | | | |
| Logic Level Low Threshold (V _{IL}) | Schmitt Trigger Input PWM = 5V (See Figure 5) | 0.8 | 1 | – | V |
| Logic Level High Threshold (V _{IH}) | | – | 1.6 | 2.0 | V |
| Threshold Hysteresis | | – | 580 | – | mV |
| Weak Pull-down Impedance | | – | 100 | – | kΩ |
| Rising Propagation Delay (t _{PDH}) | | – | 600 | – | ns |
| Falling Propagation Delay (t _{PDL}) | | – | 200 | – | ns |
| PWM | | | | | |
| I _{PWMH} | PWM = 5V | – | 620 | 800 | μA |
| I _{PWML} | PWM = 0V | – | –260 | –340 | μA |
| PWM Logic Level High (V _{PWMH}) | V _{DD} = POR to 5.5V, C _{PWM} = 10pF (See Figure 6) | – | – | 2.2 | V |
| PWM Logic Level Low (V _{PWML}) | | 0.8 | – | – | V |
| PWM 3-State open Voltage | | – | 1.5 | – | V |
| PWM to VSW propagation delay (t _{PDH} and t _{PDL}) | | – | 100 | – | ns |
| 3-State Shutdown Hold-off Time (t _{3HT}) | | – | 100 | – | ns |
| 3-State Shutdown Propagation Delay (t _{3SD}) | | – | 650 | – | ns |
| 3-State Recovery Propagation Delay (t _{3RD}) | | – | 75 | – | ns |
| BOOTSTRAP SWITCH | | | | | |
| Forward Voltage (V _{FBOOT}) | V _{DD} – V _{BOOT} , I _F = 20mA | – | 180 | 360 | mV |
| Reverse Leakage (I _{RBOOT}) ⁽²⁾ | V _{BOOT} – V _{DD} = 20V | – | 0.15 | 1 | μA |

(1) Measurement made with six 10-μF (TDK C3216X5R1C106KT or equivalent) ceramic capacitors placed across V_{IN} to P_{GND} pins.

(2) Specified by design

(3) POR to V_{SW} rising

CSD96370Q5M

SLPS265C –NOVEMBER 2010–REVISED OCTOBER 2011

www.ti.com

PIN CONFIGURATION

SON 5mm × 6mm
22-Pin Package
(Top View)

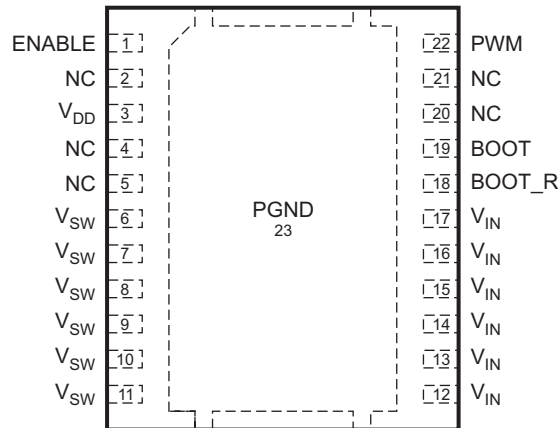

P0125-01

PIN DESCRIPTION

| PIN | | DESCRIPTION |
|-----|------------------|---|
| NO. | NAME | |
| 1 | ENABLE | Enables device operation. If ENABLE=logic HIGH, turns on the device. If ENABLE=logic LOW, the device is turned off and MOSFET gates are actively pulled low. An internal 100kΩ pull down resistor will pull the ENABLE pin LOW if left floating. |
| 2 | NC | Not for electrical connection, connect to floating pad only. |
| 3 | V _{DD} | Supply Voltage to Gate Drivers and internal circuitry. |
| 4 | NC | Not for electrical connection, connect to floating pad only. |
| 5 | NC | Not for electrical connection, connect to floating pad only. |
| 6 | V _{SW} | Voltage Switching Node – pin connection to the output inductor. |
| 7 | V _{SW} | Voltage Switching Node – pin connection to the output inductor. |
| 8 | V _{SW} | Voltage Switching Node – pin connection to the output inductor. |
| 9 | V _{SW} | Voltage Switching Node – pin connection to the output inductor. |
| 10 | V _{SW} | Voltage Switching Node – pin connection to the output inductor. |
| 11 | V _{SW} | Voltage Switching Node – pin connection to the output inductor. |
| 12 | V _{IN} | Input Voltage Pin. Connect input capacitors close to this pin. |
| 13 | V _{IN} | Input Voltage Pin. Connect input capacitors close to this pin. |
| 14 | V _{IN} | Input Voltage Pin. Connect input capacitors close to this pin. |
| 15 | V _{IN} | Input Voltage Pin. Connect input capacitors close to this pin. |
| 16 | V _{IN} | Input Voltage Pin. Connect input capacitors close to this pin. |
| 17 | V _{IN} | Input Voltage Pin. Connect input capacitors close to this pin. |
| 18 | BOOT_R | Bootstrap capacitor connection. Connect a minimum 0.1μF 16V X5R, ceramic cap from BOOT to BOOT_R pins. The bootstrap capacitor provides the charge to turn on the Control FET. The bootstrap diode is integrated. |
| 19 | BOOT | |
| 20 | NC | Not for electrical connection, connect to floating pad only. |
| 21 | NC | Not for electrical connection, connect to floating pad only. |
| 22 | PWM | Pulse Width modulated 3-state input from external controller. Logic Low sets Control FET gate low and Sync FET gate high. Logic High sets Control FET gate high and Sync FET gate Low. Open or High Z sets both MOSFET gates low if greater than the 3-State Shutdown Hold-off Time (t _{3HT}) |
| 23 | P _{GND} | Power Ground |

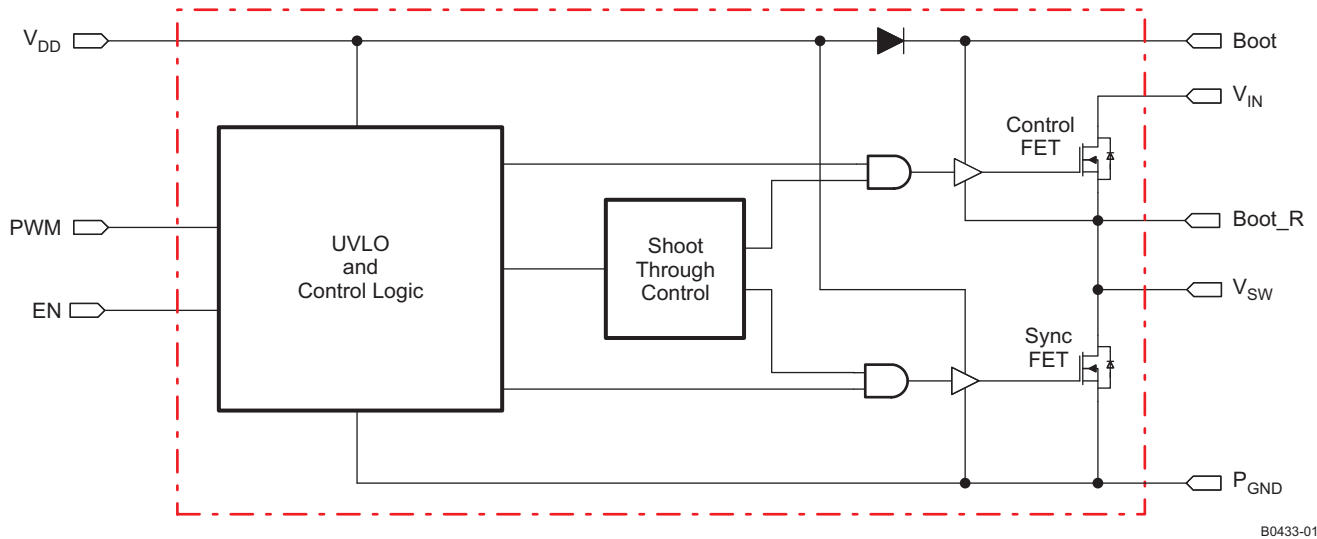
**Figure 3. Functional Block Diagram****FUNCTIONAL DESCRIPTION****POWERING CSD96370Q5M AND GATE DRIVERS**

An external V_{DD} voltage is required to supply the integrated gate driver IC and provide the necessary gate drive power for the MOSFETS. The gate driver IC is capable of supplying in excess of 4 Amps peak current into the MOSFET gates to achieve fast switching. A 1 μ F 10V X5R or higher ceramic capacitor is recommended to bypass V_{DD} pin to PGND. A bootstrap circuit to provide gate drive power for the Control FET is also included. The bootstrap supply to drive the Control FET is generated by connecting a 100nF 16V X5R ceramic capacitor between BOOT and BOOT_R pins. An optional R_{BOOT} resistor which can be used to slow down the turn on speed of the Control FET and reduce voltage spikes on the Vsw node. A typical 1 Ω to 4.7 Ω value is a compromise between switching loss and V_{SW} spike amplitude.

UVLO (Under Voltage Lock Out)

The V_{DD} supply is monitored for UVLO conditions and both Control FET and Sync FET gates are held low until adequate supply is available. An internal comparator evaluates the V_{DD} voltage level and if V_{DD} is greater than the Power On Reset threshold (V_{POR}) the gate driver becomes active. If V_{DD} is less than the UVLO threshold, the gate driver is disabled and the internal MOSFET gates are actively driven low. At the rising edge of the V_{DD} voltage, both Control FET and Sync FET gates will be actively held low during V_{DD} transitions between 1.0V to V_{POR} . This region is referred to the Gate Drive Latch Zone (see Figure 4). In addition, at the falling edge of the V_{DD} voltage, both Control FET and Sync FET gates are actively held low during the UVLO to 1.0V transition.

The Power Stage CSD96370Q5M device must be powered up and Enabled before the PWM signal is applied.

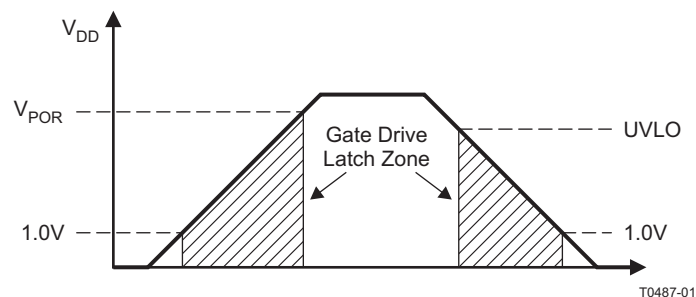
**Figure 4. POR and UVLO**

CSD96370Q5M

SLPS265C –NOVEMBER 2010–REVISED OCTOBER 2011

www.ti.com

ENABLE

The ENABLE pin is TTL compatible. The logic level thresholds are sustained under all V_{DD} operating conditions between V_{POR} to V_{DD} . In addition, if this pin is left floating, a weak internal pull down resistor of 100k Ω will pull the ENABLE pin below the logic level low threshold. The operational functions of this pin should follow the timing diagram outlined in [Figure 5](#). A logic level low will actively hold both Control FET and Sync FET gates low and V_{DD} pin should typically draw less than 5 μ A.

POWER UP SEQUENCING

If the ENABLE signal is used, it is necessary to ensure proper co-ordination with the ENABLE and soft-start features of the external PWM controller in the system. If the CSD96370Q5M was disabled through ENABLE without sequencing with the PWM IC controller, the buck converter output will have no voltage or fall below regulation set point voltage. As a result, the PWM controller IC delivers Max duty cycle on the PWM line. If the Power Stage CSD96370Q5M is re-enabled by driving the ENABLE pin high, there will be an extremely large input inrush current when the output voltage builds back up again. The input inrush current might have undesirable consequences such as inductor saturation, driving the input power supply into current limit or even catastrophic failure of the CSD96370Q5M device. Disabling the PWM controller is recommended when the CSD96370Q5M is disabled. The PWM controller should always be re-enabled by going through soft-start routine to control and minimize the input inrush current and reduce current and voltage stress on all buck converter components. It is recommended that the external PWM controller be disabled when CSD96370Q5M is disabled or nonoperational because of UVLO.

PWM

The input PWM pin incorporates a 3-State function. The Control FET and Sync FET gates are forced low if the PWM pin is left floating for more than the 3-State Hold off time (t_{3HT}), typically 100ns. This requires the source impedance of the driving PWM signal to be a minimum of 250k Ω when in 3-State mode. Operation in and out of 3-State mode should follow the timing diagram outlined in [Figure 6](#). Both V_{PWML} and V_{PWMLH} threshold levels are set to accommodate both 3.3V and 5V logic controllers. During normal operation, the PWM signal should be driven to logic levels Low and High with a maximum of 220 Ω /320 Ω sink/source impedance respectively.

GATE DRIVERS

The CSD96370Q5M has an internal high-performance gate driver IC that ensures minimum MOSFET dead-time while eliminating potential shoot-through currents. Propagation delays between the Control FET and Sync FET gates are kept to a minimum to minimize body diode conduction and improve efficiency. The gate driver IC incorporates an adaptive shoot through protection scheme which ensures that neither MOSFET is turned on while the other one is still conducting at the same time, preventing cross conduction. See [Table 1](#).

Table 1. Truth Table

| ENABLE | PWM | CONTROL FET GATE | SYNC FET GATE | V_{sw} |
|--------|--------------|------------------|---------------|-----------|
| L | X | L | L | 3-State |
| H | <Min ON time | L | L | 3-State |
| H | L | L | H | P_{GND} |
| H | 3-State | L | L | 3-State |
| H | H | H | L | V_{IN} |

L = Logic Low; H = Logic High; X = Don't care; minimum on time = 40ns

START UP IN PRE-BIASED OUTPUT VOLTAGE

The CSD96370Q5M incorporates a simple pre-bias feature to protect against the discharging of a prebiased output voltage and inducing large negative inductor currents. After the Power On Reset threshold is crossed and the ENABLE pin is set to logic level high, both internal MOSFETs are actively held low until the PWM pin receives a signal that crosses logic level high threshold and meets the minimum on time criteria (see the *Electrical Characteristics Table*). This allows the PWM control IC to provide a soft start routine that creates a monotonic startup of the output voltage. The pre-bias feature is enabled for a single event and subsequent PWM signals creates normal switching of the internal MOSFETs (see [Table 1](#)). To reactivate the pre-bias feature, the ENABLE pin needs to be pulled below logic level low or the V_{DD} supply voltage needs to cross UVLO.

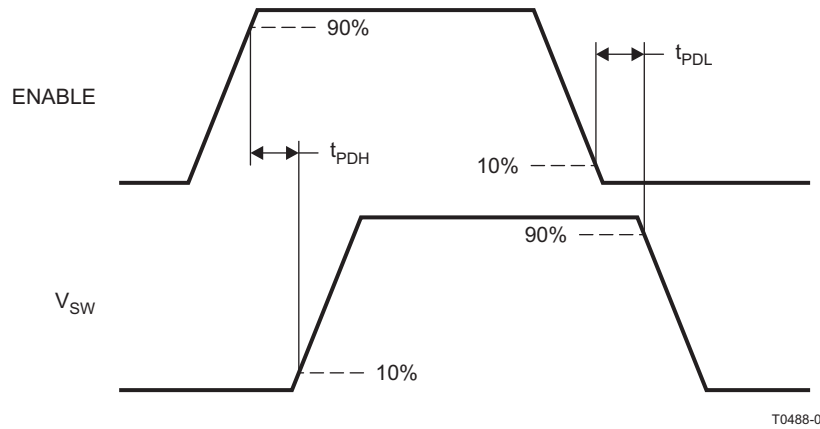

T0488-01

Figure 5. CSD96370Q5M ENABLE Timing Diagram ($V_{DD} = PWM = 5V$)

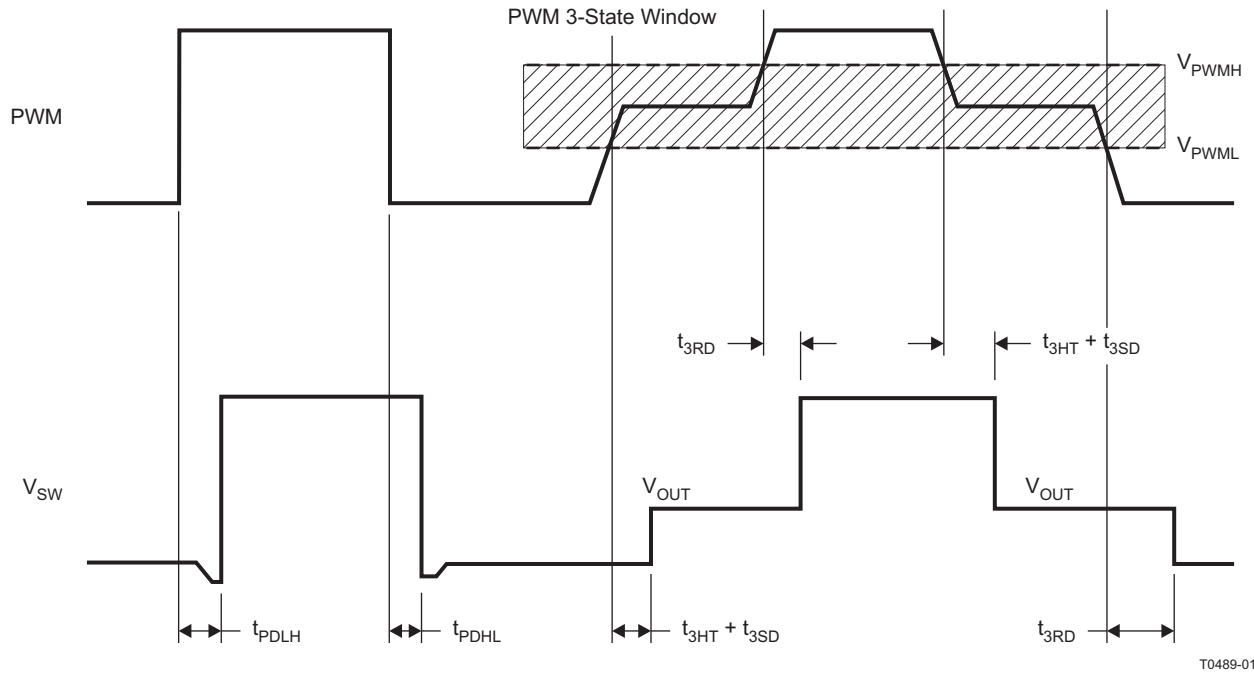

T0489-01

Figure 6. CSD96370Q5M PWM Timing Diagram

CSD96370Q5M

SLPS265C –NOVEMBER 2010–REVISED OCTOBER 2011

www.ti.com

TYPICAL CHARACTERISTICS

Test conditions: $V_{IN} = 12V$, $V_{DD} = 5V$, $f_{SW} = 500kHz$, $V_{OUT} = 1.2V$, $L_{OUT} = 0.3\mu H$, $DCR = 0.54m\Omega$, $T_J = 125^\circ C$

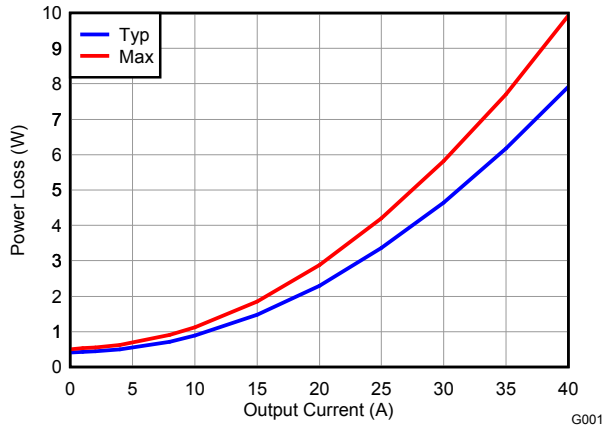

Figure 7. Power Loss vs Output Current

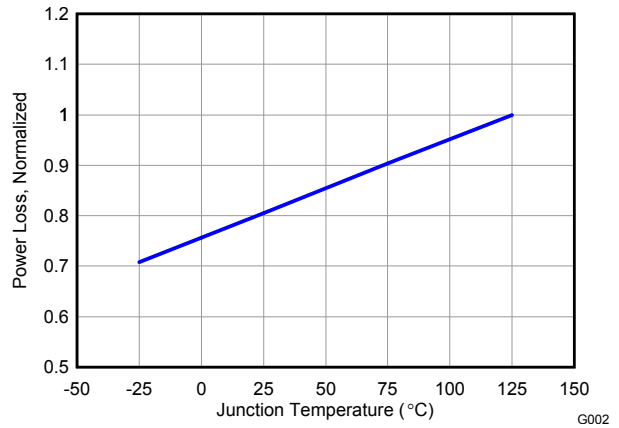

Figure 8. Power Loss vs Temperature

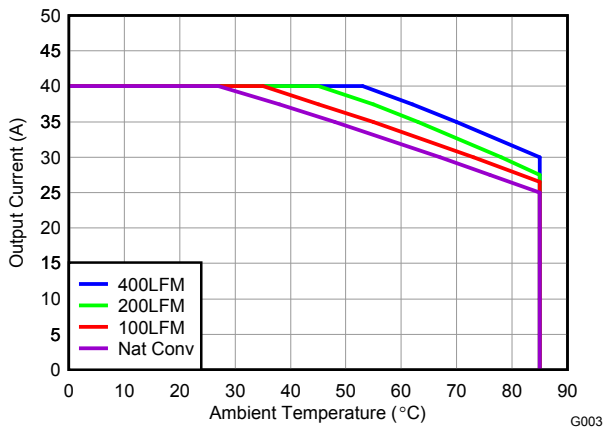

Figure 9. Safe Operating Area – PCB Vertical Mount ⁽¹⁾

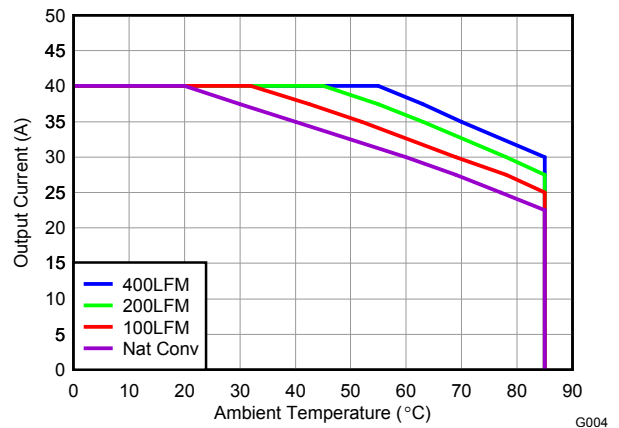

Figure 10. Safe Operating Area – PCB Horizontal Mount ⁽¹⁾

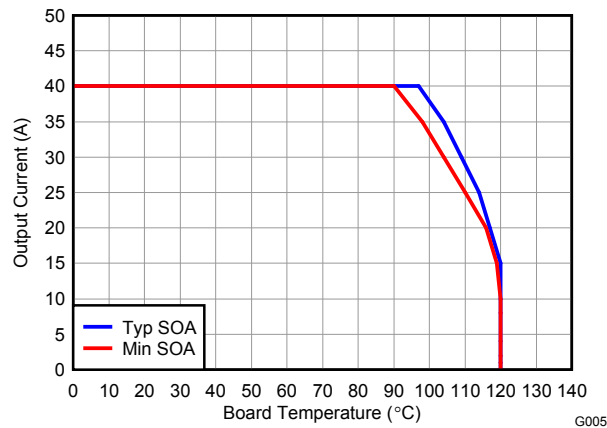

Figure 11. Typical and Min Safe Operating Area ⁽¹⁾

1. The Typical CSD96370Q5M System Characteristic curves are based on measurements made on a PCB design with dimensions of 4.0" (W) x 3.5" (L) x 0.062" (T) and 6 copper layers of 1 oz. copper thickness. See the *Application section* for detailed explanation.

TYPICAL CHARACTERISTICS

Test conditions: $V_{IN} = 12V$, $V_{DD} = 5V$, $f_{SW} = 500kHz$, $V_{OUT} = 1.2V$, $L_{OUT} = 0.3\mu H$, $DCR = 0.54m\Omega$, $T_J = 125^\circ C$

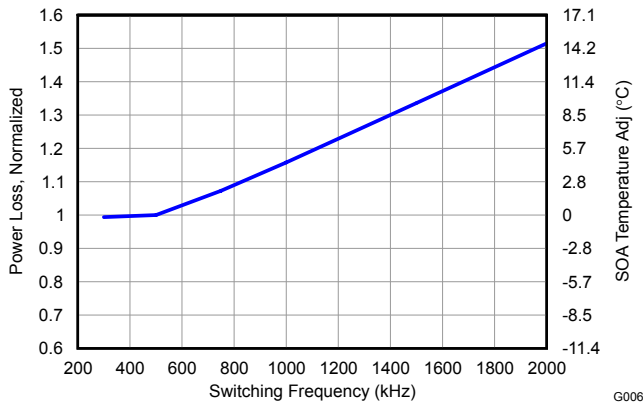

Figure 12. Normalized Power Loss vs Frequency

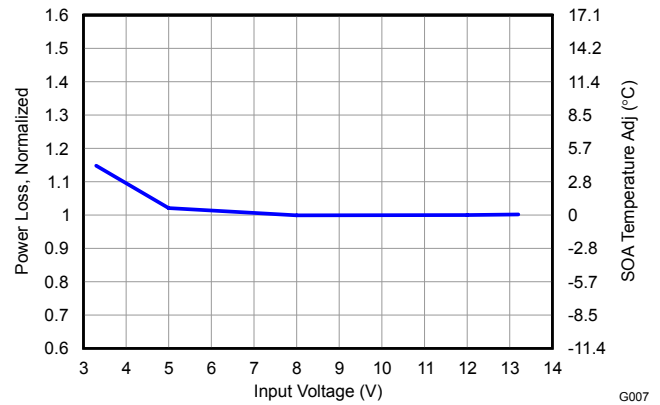

Figure 13. Normalized Power Loss vs Input Voltage

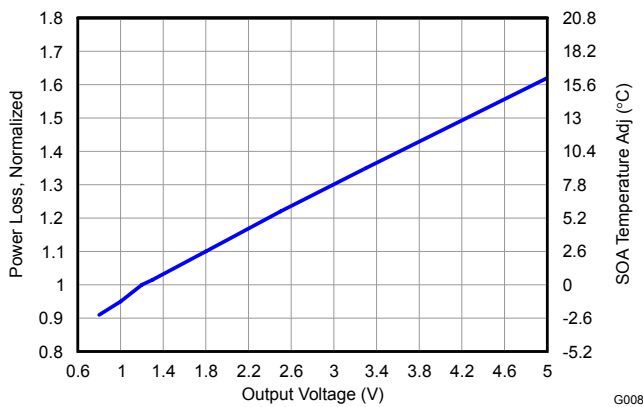

Figure 14. Normalized Power Loss vs Output Voltage

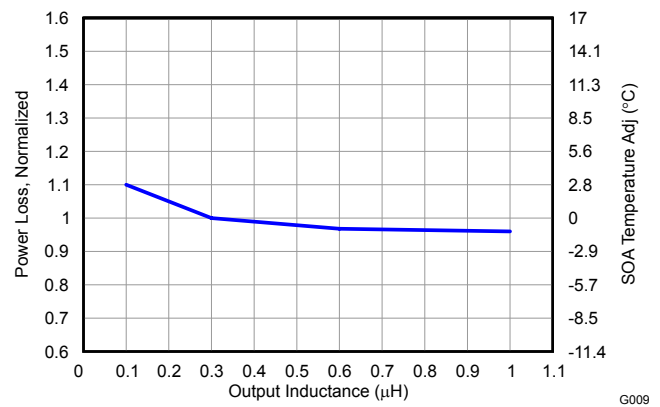

Figure 15. Normalized Power Loss vs Output Inductance

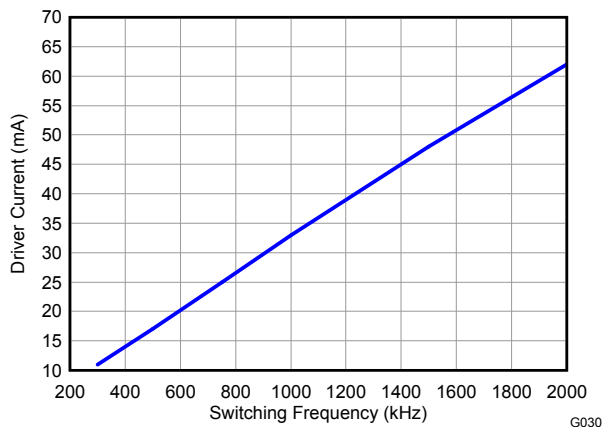

Figure 16. Driver Current vs Frequency

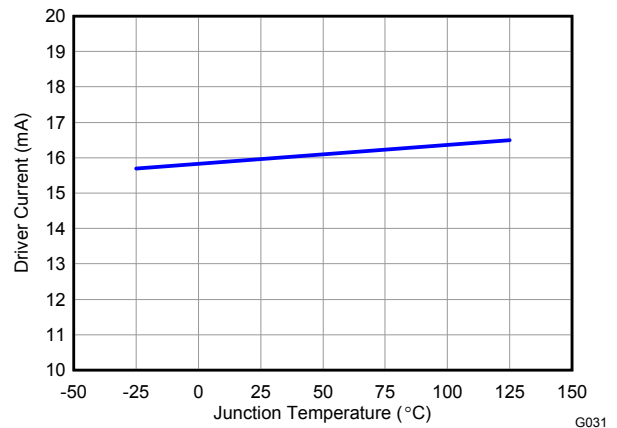

Figure 17. Driver Current vs Temperature

CSD96370Q5M

SLPS265C –NOVEMBER 2010–REVISED OCTOBER 2011

www.ti.com

APPLICATION INFORMATION

The Power Stage CSD96370Q5M is a highly optimized design for synchronous buck applications using NexFET devices with a 5V gate drive. The Control FET and Sync FET silicon are parametrically tuned to yield the lowest power loss and highest system efficiency. As a result, a rating method is used that is tailored towards a more systems centric environment. The high-performance gate driver IC integrated in the package helps minimize the parasitics and results in extremely fast switching of the power MOSFETs. System level performance curves such as Power Loss, Safe Operating Area and normalized graphs allow engineers to predict the product performance in the actual application.

Power Loss Curves

MOSFET centric parameters such as $R_{DS(ON)}$ and Q_{gd} are primarily needed by engineers to estimate the loss generated by the devices. In an effort to simplify the design process for engineers, Texas Instruments has provided measured power loss performance curves. [Figure 7](#) plots the power loss of the CSD96370Q5M as a function of load current. This curve is measured by configuring and running the CSD96370Q5M as it would be in the final application (see [Figure 18](#)). The measured power loss is the CSD96370Q5M device power loss which consists of both input conversion loss and gate drive loss. [Equation 1](#) is used to generate the power loss curve.

$$\text{Power Loss} = (V_{IN} \times I_{IN}) + (V_{DD} \times I_{DD}) - (V_{SW_AVG} \times I_{OUT}) \quad (1)$$

The power loss curve in [Figure 7](#) is measured at the maximum recommended junction temperature of $T_J = 125^\circ\text{C}$ under isothermal test conditions.

Safe Operating Curves (SOA)

The SOA curves in the CSD96370Q5M datasheet give engineers guidance on the temperature boundaries within an operating system by incorporating the thermal resistance and system power loss. [Figure 9](#), [Figure 10](#), and [Figure 11](#) outline the temperature and airflow conditions required for a given load current. The area under the curve dictates the safe operating area. All the curves are based on measurements made on a PCB design with dimensions of 4.0" (W) x 3.5" (L) x 0.062" (T) and 6 copper layers of 1 oz. copper thickness.

Normalized Curves

The normalized curves in the CSD96370Q5M data sheet give engineers guidance on the Power Loss and SOA adjustments based on their application specific needs. These curves show how the power loss and SOA boundaries will adjust for a given set of systems conditions. The primary Y-axis is the normalized change in power loss and the secondary Y-axis is the change in system temperature required in order to comply with the SOA curve. The change in power loss is a multiplier for the Power Loss curve and the change in temperature is subtracted from the SOA curve.

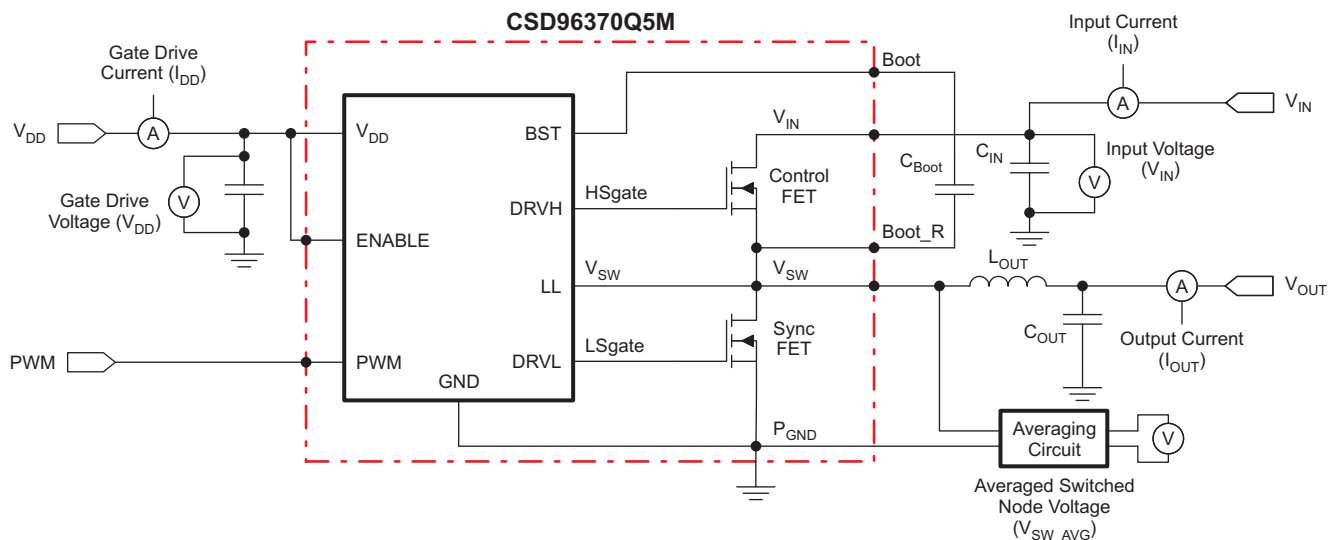

S0489-01

Figure 18. Power Loss Test Circuit

Calculating Power Loss and SOA

The user can estimate product loss and SOA boundaries by arithmetic means (see the Design Example). Though the Power Loss and SOA curves in this datasheet are taken for a specific set of test conditions, the following procedure will outline the steps engineers should take to predict product performance for any set of system conditions.

Design Example

Operating Conditions: Output Current (I_{OUT}) = 25A, Input Voltage (V_{IN}) = 7V, Output Voltage (V_{OUT}) = 1V, Switching Frequency (f_{SW}) = 800kHz, Output Inductor (L_{OUT}) = 0.2 μ H

Calculating Power Loss

- Power Loss at 25A = 3.3W (Figure 7)
- Normalized Power Loss for switching frequency \approx 1.09 (Figure 12)
- Normalized Power Loss for input voltage \approx 1.07 (Figure 13)
- Normalized Power Loss for output voltage \approx 0.95 (Figure 14)
- Normalized Power Loss for output inductor \approx 1.06 (Figure 15)
- **Final calculated Power Loss = 3.3W \times 1.09 \times 1.07 \times 0.95 \times 1.06 \approx 3.88W**

Calculating SOA Adjustments

- SOA adjustment for switching frequency \approx 2.7 $^{\circ}$ C (Figure 12)
- SOA adjustment for input voltage \approx 0.1 $^{\circ}$ C (Figure 13)
- SOA adjustment for output voltage \approx -1.3 $^{\circ}$ C (Figure 14)
- SOA adjustment for output inductor \approx 1.6 $^{\circ}$ C (Figure 15)
- **Final calculated SOA adjustment = 2.7 + 0.1 + (-1.3) + 1.6 \approx 3.1 $^{\circ}$ C**

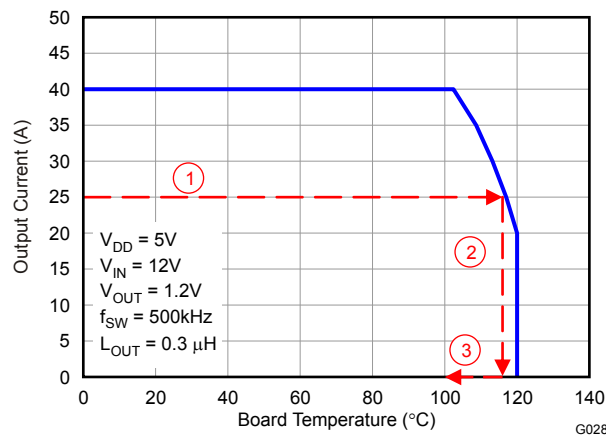

Figure 19. Power Stage CSD96370Q5M SOA

In the design example above, the estimated power loss of the CSD96370Q5M would increase to 3.88W. In addition, the maximum allowable board and/or ambient temperature would have to decrease by 3.1 $^{\circ}$ C. Figure 19 graphically shows how the SOA curve would be adjusted accordingly.

1. Start by drawing a horizontal line from the application current to the SOA curve.
2. Draw a vertical line from the SOA curve intercept down to the board/ambient temperature.
3. Adjust the SOA board/ambient temperature by subtracting the temperature adjustment value.

In the design example, the SOA temperature adjustment yields a reduction in allowable board/ambient temperature of 3.1 $^{\circ}$ C. In the event the adjustment value is a negative number, subtracting the negative number would yield an increase in allowable board/ambient temperature.

CSD96370Q5M

SLPS265C –NOVEMBER 2010–REVISED OCTOBER 2011

www.ti.com

RECOMMENDED PCB DESIGN OVERVIEW

There are two key system-level parameters that can be addressed with a proper PCB design: electrical and thermal performance. Properly optimizing the PCB layout will yield maximum performance in both areas. Below is a brief description on how to address each parameter.

Electrical Performance

The CSD96370Q5M has the ability to switch at voltages rates greater than 10kV/μs. Special care must be then taken with the PCB layout design and placement of the input capacitors, inductor and output capacitors.

- The placement of the input capacitors relative to V_{IN} and P_{GND} pins of CSD96370Q5M device should have the highest priority during the component placement routine. It is critical to minimize these node lengths. As such, ceramic input capacitors need to be placed as close as possible to the V_{IN} and P_{GND} pins (see Figure 20). The example in Figure 20 uses 6 x 10μF 1206 25V ceramic capacitors (TDK Part # C3216X5R1C106KT or equivalent). Notice there are ceramic capacitors on both sides of the board with an appropriate amount of vias interconnecting both layers. In terms of priority of placement next to the Power Stage C5, C8 and C7, C19 should follow in order.
- The bootstrap cap C_{BOOT} 0.1μF 0603 16V ceramic capacitor should be closely connected between BOOT and BOOT_R pins
- The switching node of the output inductor should be placed relatively close to the Power Stage CSD96370Q5M V_{SW} pins. Minimizing the V_{SW} node length between these two components will reduce the PCB conduction losses and actually reduce the switching noise level.⁽¹⁾

Thermal Performance

The CSD96370Q5M has the ability to use the GND planes as the primary thermal path. As such, the use of thermal vias is an effective way to pull away heat from the device and into the system board. Concerns of solder voids and manufacturability problems can be addressed by the use of three basic tactics to minimize the amount of solder attach that will wick down the via barrel:

- Intentionally space out the vias from each other to avoid a cluster of holes in a given area.
- Use the smallest drill size allowed in your design. The example in Figure 20 uses vias with a 10 mil drill hole and a 16 mil capture pad.
- Tent the opposite side of the via with solder-mask.

In the end, the number and drill size of the thermal vias should align with the end user's PCB design rules and manufacturing capabilities.

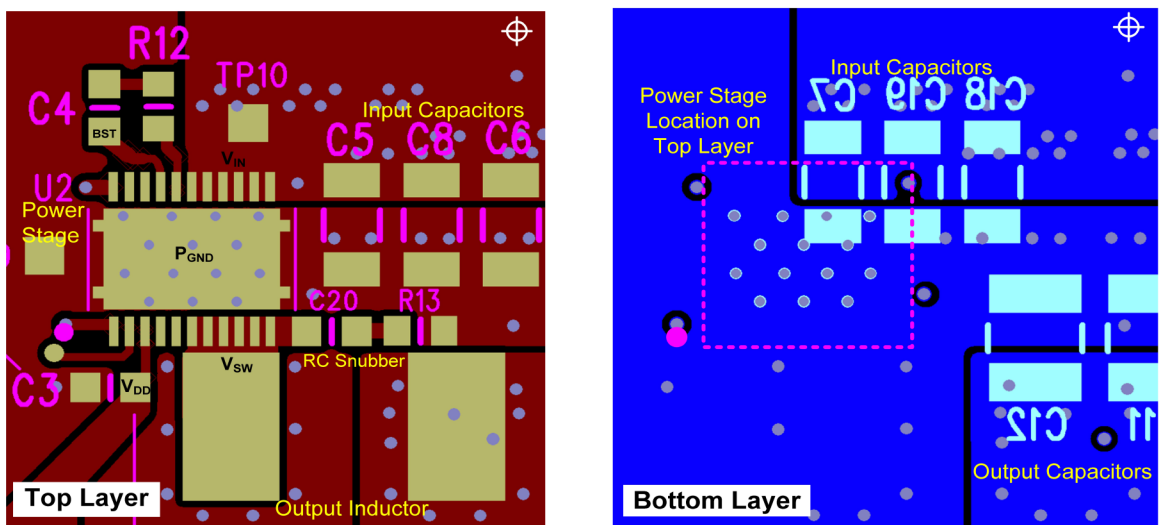

K001

Figure 20. Recommended PCB Layout (Top Down View)

(1) Keong W. Kam, David Pommerenke, "EMI Analysis Methods for Synchronous Buck Converter EMI Root Cause Analysis", University of Missouri – Rolla

MECHANICAL DATA

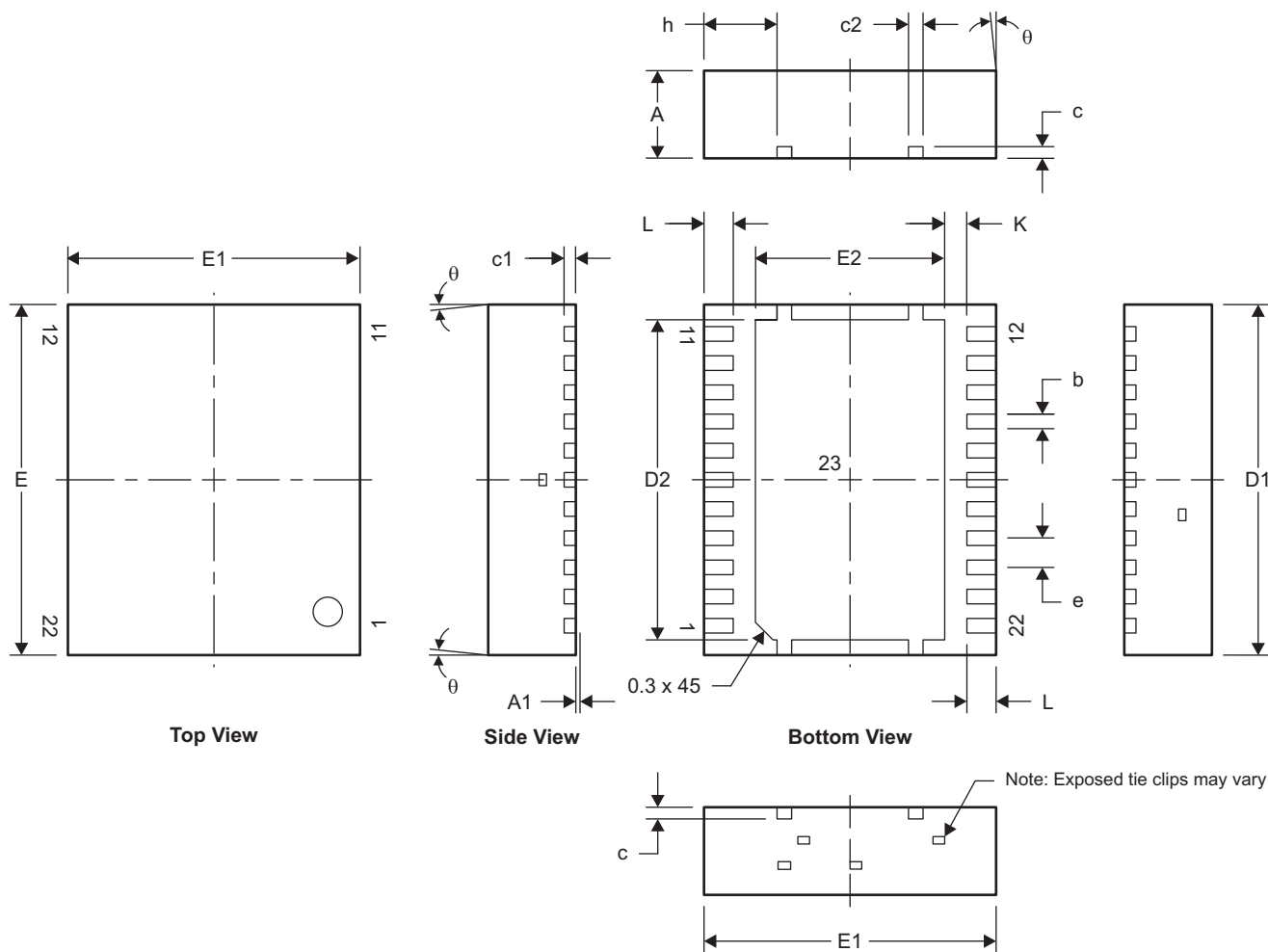

M0201-01

| DIM | MILLIMETERS | | | INCHES | | |
|-----|-------------|-------|-------|-----------|-------|-------|
| | Min | Nom | Max | Min | Nom | Max |
| A | 1.400 | 1.450 | 1.500 | 0.055 | 0.057 | 0.059 |
| A1 | 0.000 | 0.000 | 0.050 | 0.000 | 0.000 | 0.002 |
| b | 0.200 | 0.250 | 0.350 | 0.008 | 0.010 | 0.014 |
| c | 0.150 | 0.200 | 0.250 | 0.006 | 0.008 | 0.010 |
| c1 | 0.150 | 0.200 | 0.250 | 0.006 | 0.008 | 0.010 |
| c2 | 0.200 | 0.250 | 0.300 | 0.008 | 0.010 | 0.012 |
| D1 | 5.900 | 6.000 | 6.100 | 0.232 | 0.236 | 0.240 |
| D2 | 5.379 | 5.479 | 5.579 | 0.212 | 0.216 | 0.220 |
| E | 5.900 | 6.000 | 6.100 | 0.232 | 0.236 | 0.240 |
| E1 | 4.900 | 5.000 | 5.100 | 0.193 | 0.197 | 0.201 |
| E2 | 3.140 | 3.240 | 3.340 | 0.124 | 0.128 | 0.132 |
| e | 0.500 TYP | | | 0.020 TYP | | |
| h | 1.150 | 1.250 | 1.350 | 0.045 | 0.049 | 0.053 |
| K | 0.380 TYP | | | 0.015 TYP | | |
| L | 0.400 | 0.500 | 0.600 | 0.016 | 0.020 | 0.024 |
| θ | 0.00 | — | — | 0.00 | — | — |

CSD96370Q5M

SLPS265C –NOVEMBER 2010–REVISED OCTOBER 2011

www.ti.com

Land Pattern Recommendation

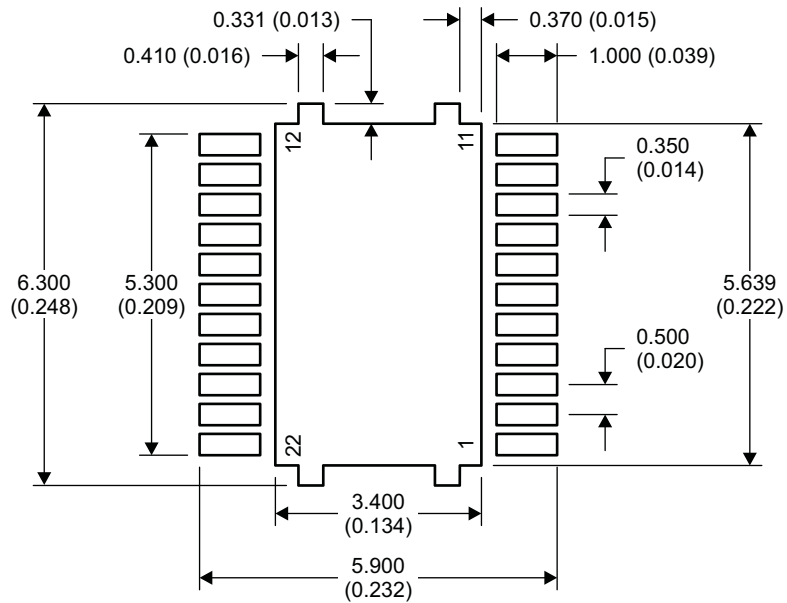

M0202-01

NOTE: Dimensions are in mm (inches).

Stencil Recommendation

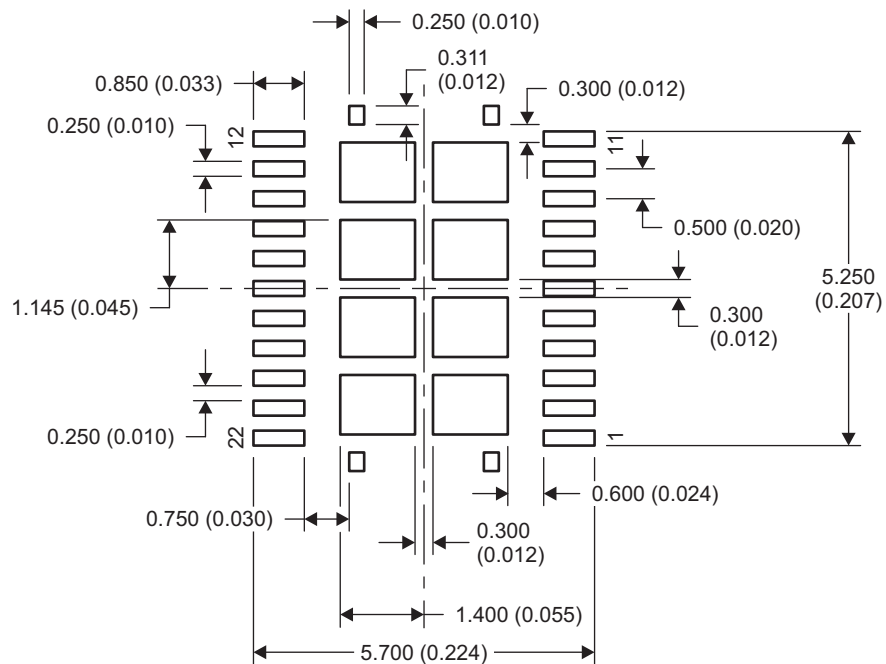

M0204-01

NOTE: Dimensions are in mm (inches).

REVISION HISTORY**Changes from Original (November 2010) to Revision A** **Page**

- Added the Operating Junction Temperature Range in the Abs Max Table **2**

Changes from Revision A (January 2011) to Revision B **Page**

- Changed the Abs Max Ratings table: Added new Note 2. Added new rows - V_{sw} to P_{GND} and V_{sw} to P_{GND} (10ns) **2**

Changes from Revision B (May 2011) to Revision C **Page**

- Changed [Figure 11](#) **8**
- Changed DIM A values **13**
- Changed DIM b Max Millimeters From: 0.320 To: 0.350 and Max Inches From: 0.013 To 0.014 **13**
- Changed lead width From: 0.300(0.012) To: 0.350(0.014) **14**

PACKAGING INFORMATION

| Orderable part number | Status (1) | Material type (2) | Package Pins | Package qty Carrier | RoHS (3) | Lead finish/ Ball material (4) | MSL rating/ Peak reflow (5) | Op temp (°C) | Part marking (6) |
|-----------------------------|---------------|----------------------|----------------------|-----------------------|-------------|--------------------------------------|-----------------------------------|--------------|---------------------|
| CSD96370Q5M | Active | Production | LSON-CLIP (DQP) 22 | 2500 LARGE T&R | ROHS Exempt | NIPDAU | Level-2-260C-1 YEAR | -55 to 150 | 96370M |

(1) **Status:** For more details on status, see our [product life cycle](#).

(2) **Material type:** When designated, preproduction parts are prototypes/experimental devices, and are not yet approved or released for full production. Testing and final process, including without limitation quality assurance, reliability performance testing, and/or process qualification, may not yet be complete, and this item is subject to further changes or possible discontinuation. If available for ordering, purchases will be subject to an additional waiver at checkout, and are intended for early internal evaluation purposes only. These items are sold without warranties of any kind.

(3) **RoHS values:** Yes, No, RoHS Exempt. See the [TI RoHS Statement](#) for additional information and value definition.

(4) **Lead finish/Ball material:** Parts may have multiple material finish options. Finish options are separated by a vertical ruled line. Lead finish/Ball material values may wrap to two lines if the finish value exceeds the maximum column width.

(5) **MSL rating/Peak reflow:** The moisture sensitivity level ratings and peak solder (reflow) temperatures. In the event that a part has multiple moisture sensitivity ratings, only the lowest level per JEDEC standards is shown. Refer to the shipping label for the actual reflow temperature that will be used to mount the part to the printed circuit board.

(6) **Part marking:** There may be an additional marking, which relates to the logo, the lot trace code information, or the environmental category of the part.

Multiple part markings will be inside parentheses. Only one part marking contained in parentheses and separated by a "-" will appear on a part. If a line is indented then it is a continuation of the previous line and the two combined represent the entire part marking for that device.

Important Information and Disclaimer: The information provided on this page represents TI's knowledge and belief as of the date that it is provided. TI bases its knowledge and belief on information provided by third parties, and makes no representation or warranty as to the accuracy of such information. Efforts are underway to better integrate information from third parties. TI has taken and continues to take reasonable steps to provide representative and accurate information but may not have conducted destructive testing or chemical analysis on incoming materials and chemicals. TI and TI suppliers consider certain information to be proprietary, and thus CAS numbers and other limited information may not be available for release.

In no event shall TI's liability arising out of such information exceed the total purchase price of the TI part(s) at issue in this document sold by TI to Customer on an annual basis.

TAPE AND REEL INFORMATION

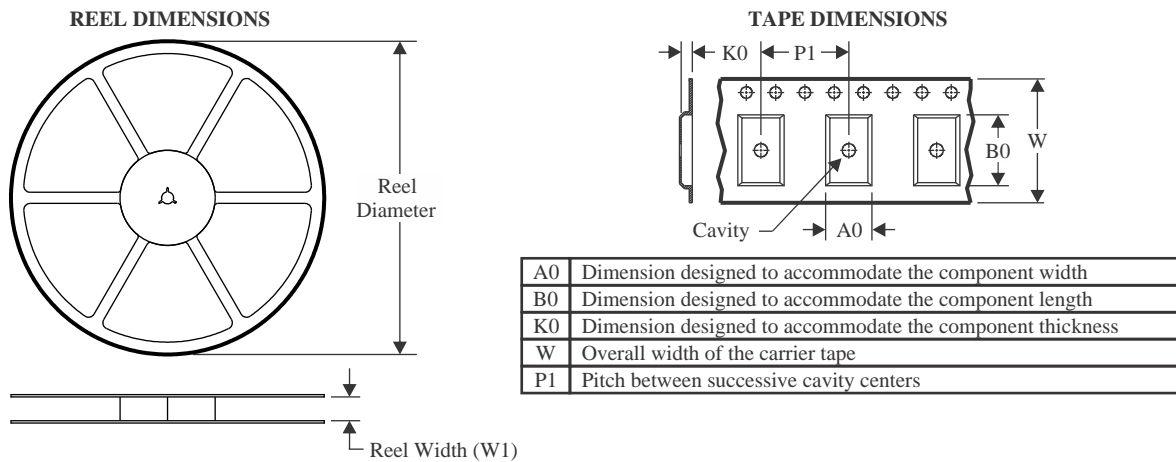

QUADRANT ASSIGNMENTS FOR PIN 1 ORIENTATION IN TAPE

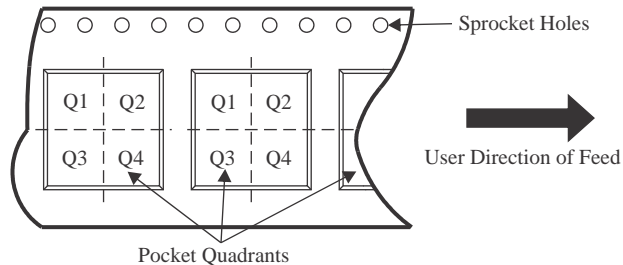

*All dimensions are nominal

| Device | Package Type | Package Drawing | Pins | SPQ | Reel Diameter (mm) | Reel Width W1 (mm) | A0 (mm) | B0 (mm) | K0 (mm) | P1 (mm) | W (mm) | Pin1 Quadrant |
|-------------|--------------|-----------------|------|------|--------------------|--------------------|---------|---------|---------|---------|--------|---------------|
| CSD96370Q5M | LS0N-CLIP | DQP | 22 | 2500 | 330.0 | 12.4 | 5.3 | 6.3 | 1.8 | 8.0 | 12.0 | Q1 |

TAPE AND REEL BOX DIMENSIONS

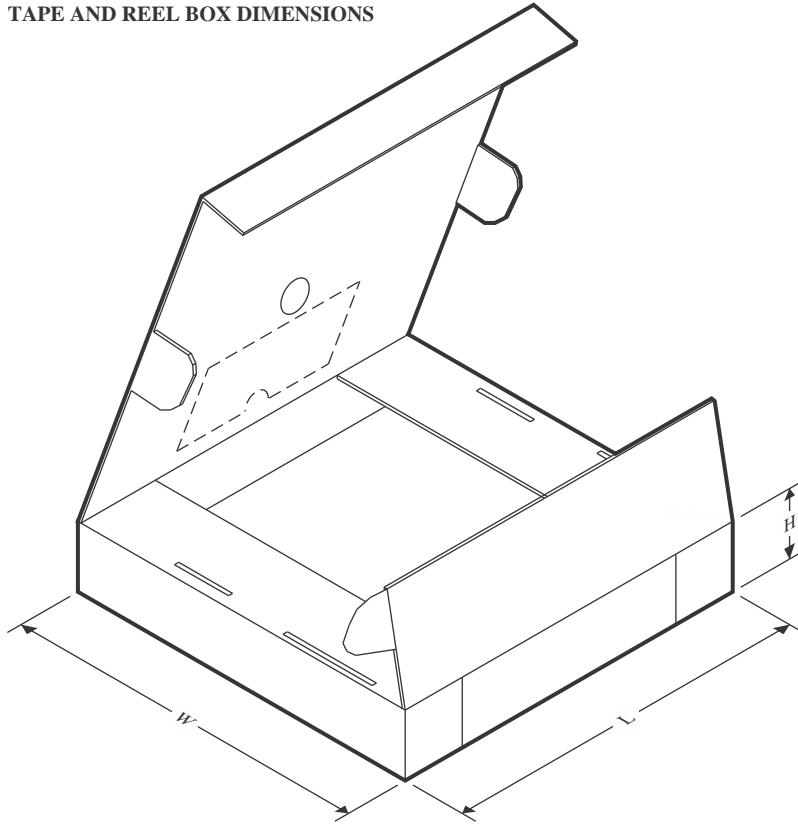

*All dimensions are nominal

| Device | Package Type | Package Drawing | Pins | SPQ | Length (mm) | Width (mm) | Height (mm) |
|-------------|--------------|-----------------|------|------|-------------|------------|-------------|
| CSD96370Q5M | LSON-CLIP | DQP | 22 | 2500 | 346.0 | 346.0 | 33.0 |

IMPORTANT NOTICE AND DISCLAIMER

TI PROVIDES TECHNICAL AND RELIABILITY DATA (INCLUDING DATASHEETS), DESIGN RESOURCES (INCLUDING REFERENCE DESIGNS), APPLICATION OR OTHER DESIGN ADVICE, WEB TOOLS, SAFETY INFORMATION, AND OTHER RESOURCES "AS IS" AND WITH ALL FAULTS, AND DISCLAIMS ALL WARRANTIES, EXPRESS AND IMPLIED, INCLUDING WITHOUT LIMITATION ANY IMPLIED WARRANTIES OF MERCHANTABILITY, FITNESS FOR A PARTICULAR PURPOSE OR NON-INFRINGEMENT OF THIRD PARTY INTELLECTUAL PROPERTY RIGHTS.

These resources are intended for skilled developers designing with TI products. You are solely responsible for (1) selecting the appropriate TI products for your application, (2) designing, validating and testing your application, and (3) ensuring your application meets applicable standards, and any other safety, security, regulatory or other requirements.

These resources are subject to change without notice. TI grants you permission to use these resources only for development of an application that uses the TI products described in the resource. Other reproduction and display of these resources is prohibited. No license is granted to any other TI intellectual property right or to any third party intellectual property right. TI disclaims responsibility for, and you fully indemnify TI and its representatives against any claims, damages, costs, losses, and liabilities arising out of your use of these resources.

TI's products are provided subject to [TI's Terms of Sale](#), [TI's General Quality Guidelines](#), or other applicable terms available either on [ti.com](#) or provided in conjunction with such TI products. TI's provision of these resources does not expand or otherwise alter TI's applicable warranties or warranty disclaimers for TI products. Unless TI explicitly designates a product as custom or customer-specified, TI products are standard, catalog, general purpose devices.

TI objects to and rejects any additional or different terms you may propose.

Copyright © 2026, Texas Instruments Incorporated

Last updated 10/2025

OUR CERTIFICATE

DiGi provide top-quality products and perfect service for customer worldwide through standardization, technological innovation and continuous improvement. DiGi through third-party certification, we stricly control the quality of products and services. Welcome your RFQ to

Email: Info@DiGi-Electronics.com



Tel: +00 852-30501935

RFQ Email: Info@DiGi-Electronics.com

DiGi is a global authorized distributor of electronic components.