

DS80PCI800SQE/NOPB Datasheet

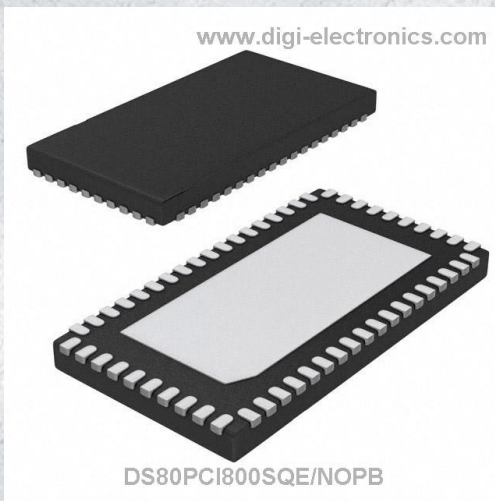

<https://www.DiGi-Electronics.com>

DiGi Electronics Part Number	DS80PCI800SQE/NOPB-DG
Manufacturer	Texas Instruments
Manufacturer Product Number	DS80PCI800SQE/NOPB
Description	IC REDRIVER PCIE 8CH 54WQFN
Detailed Description	Buffer, ReDriver 8 Channel 8Gbps 54-WQFN (10x5.5)



Tel: +00 852-30501935

RFQ Email: Info@DiGi-Electronics.com

DiGi is a global authorized distributor of electronic components.

Purchase and inquiry

Manufacturer Product Number:

DS80PCI800SQE/NOPB

Series:

-

Type:

Buffer, ReDriver

Input:

CML

Data Rate (Max):

8Gbps

Delay Time:

200ps

Capacitance - Input:

10 pF

Current - Supply:

-

Mounting Type:

Surface Mount

Supplier Device Package:

54-WQFN (10x5.5)

Manufacturer:

Texas Instruments

Product Status:

Active

Applications:

PCIe

Output:

CML

Number of Channels:

8

Signal Conditioning:

Input Equalization, Output De-Emphasis

Voltage - Supply:

2.375V ~ 3.6V

Operating Temperature:

-40°C ~ 85°C

Package / Case:

54-WFQFN Exposed Pad

Base Product Number:

DS80PCI800

Environmental & Export classification

RoHS Status:

ROHS3 Compliant

REACH Status:

REACH Unaffected

HTSUS:

8542.39.0001

Moisture Sensitivity Level (MSL):

2 (1 Year)

ECCN:

5A991B1

DS80PCI800 2.5-Gbps / 5.0-Gbps / 8.0-Gbps 8-Channel PCI-Express™ Repeater With Equalization and De-Emphasis

1 Features

- Comprehensive Family, Proven System Interoperability
 - DS80PCI102 : x1 PCIe Gen-1, Gen-2, and Gen-3
 - DS80PCI402 : x4 PCIe Gen-1, Gen-2, and Gen-3
 - DS80PCI800** : x8/x16 PCIe Gen-1, Gen-2, and Gen-3
- Automatic Rate Detect and Adaptation to Gen-1/2/3 Speeds
- Seamless Support for Gen-3 Transmit FIR Handshake
- Receiver EQ (up to 36 dB), Transmit De-Emphasis (up to 12 dB)
- Adjustable Transmit VOD: 0.8 to 1.3 Vp-p (Pin Mode)
- 0.2 UI of Residual Deterministic Jitter at 8 Gbps After 40 Inches of FR4 or 10 m 30-awg PCIe Cable
- Low Power Dissipation With Ability to Turn Off Unused Channels: 65 mW/Channel
- Automatic Receiver Detect (Hot-Plug)
- Multiple Configuration Modes: Pins/SMBus/Direct-EEPROM Load
- Flow-Thru Pinout: 54-Pin WQFN (10-mm x 5.5-mm, 0.5-mm Pitch)
- Single Supply Voltage: 2.5 or 3.3 V (Selectable)
- ±3 kV HBM ESD Rating
- 40°C to 85°C Operating Temperature Range

2 Applications

- PCI Express Gen-1, Gen-2, and Gen-3

3 Description

The DS80PCI800 is a low-power, 8-channel repeater with 4-stage input equalization, and an output de-emphasis driver to enhance the reach of PCI-Express serial links in board-to-board or cable interconnects. This device is ideal for higher density x8 and x16 PCI-Express configurations, and it automatically detects and adapts to Gen-1, Gen-2, and Gen-3 data rates for easy system upgrade.

DS80PCI800 offers programmable transmit de-emphasis (up to 12 dB), transmit VOD (up to 1300 mVp-p) and receive equalization (up to 36 dB) to enable longer distance transmission in lossy copper cables (10 meters or more), or backplanes (40 inches or more) with multiple connectors. The receiver can open an input eye that is completely closed due to inter-symbol interference (ISI) introduced by the interconnect medium.

The programmable settings can be applied easily through pins or software (SMBus/I²C), or can be loaded through an external EEPROM. When operating in the EEPROM mode, the configuration information is automatically loaded on power up, which eliminates the need for an external microprocessor or software driver.

Device Information⁽¹⁾

PART NUMBER	PACKAGE	BODY SIZE (NOM)
DS80PCI800	WQFN (54)	10.00 mm x 5.50 mm

(1) For all available packages, see the orderable addendum at the end of the data sheet.

Typical Application Block Diagram

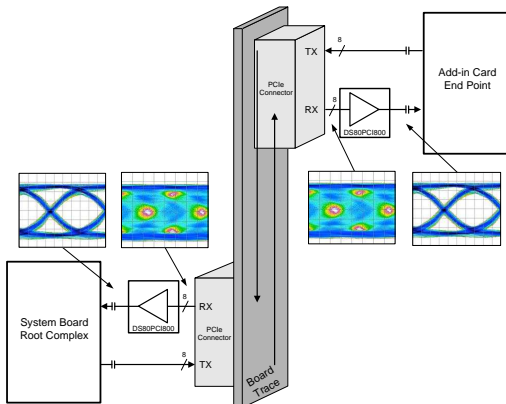

Simplified Schematic Diagram

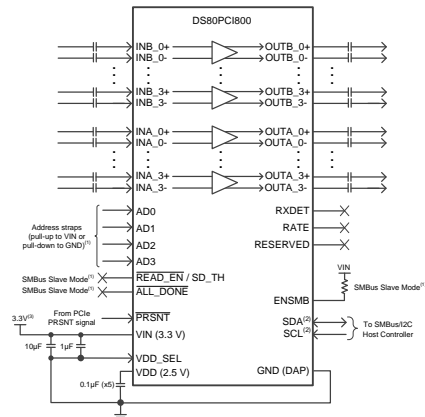

(1) Schematic shows connection for SMBus Slave Mode (ENSMB=1kohm to VDD). For SMBus Master Mode or Pin Mode configuration, the connections are different.
 (2) SMBus signals need to be pulled up elsewhere in the system.
 (3) Schematic requires different connections for 2.5 V mode.

Table of Contents

1 Features	1	8.4 Device Functional Modes	16
2 Applications	1	8.5 Programming	16
3 Description	1	8.6 Register Maps	20
4 Revision History	2	9 Application and Implementation	40
5 Pin Configuration and Functions	3	9.1 Application Information	40
6 Specifications	6	9.2 Typical Application	41
6.1 Absolute Maximum Ratings	6	10 Power Supply Recommendations	43
6.2 ESD Ratings	6	10.1 3.3-V or 2.5-V Supply Mode Operation	43
6.3 Recommended Operating Ratings	6	10.2 Power Supply Bypassing	44
6.4 Electrical Characteristics	7	11 Layout	45
6.5 Electrical Characteristics — Serial Management Bus Interface	10	11.1 Layout Guidelines	45
6.6 Typical Characteristics	11	11.2 Layout Example	45
7 Parameter Measurement Information	12	12 Device and Documentation Support	46
8 Detailed Description	13	12.1 Device Support	46
8.1 Overview	13	12.2 Trademarks	46
8.2 Functional Block Diagram	13	12.3 Electrostatic Discharge Caution	46
8.3 Feature Description	14	12.4 Glossary	46
		13 Mechanical, Packaging, and Orderable Information	46

4 Revision History

Changes from Revision F (April 2013) to Revision G

Page

- Added *ESD Ratings* table, *Feature Description* section, *Device Functional Modes*, *Application and Implementation* section, *Power Supply Recommendations* section, *Layout* section, *Device and Documentation Support* section, and *Mechanical, Packaging, and Orderable Information* section 1

5 Pin Configuration and Functions

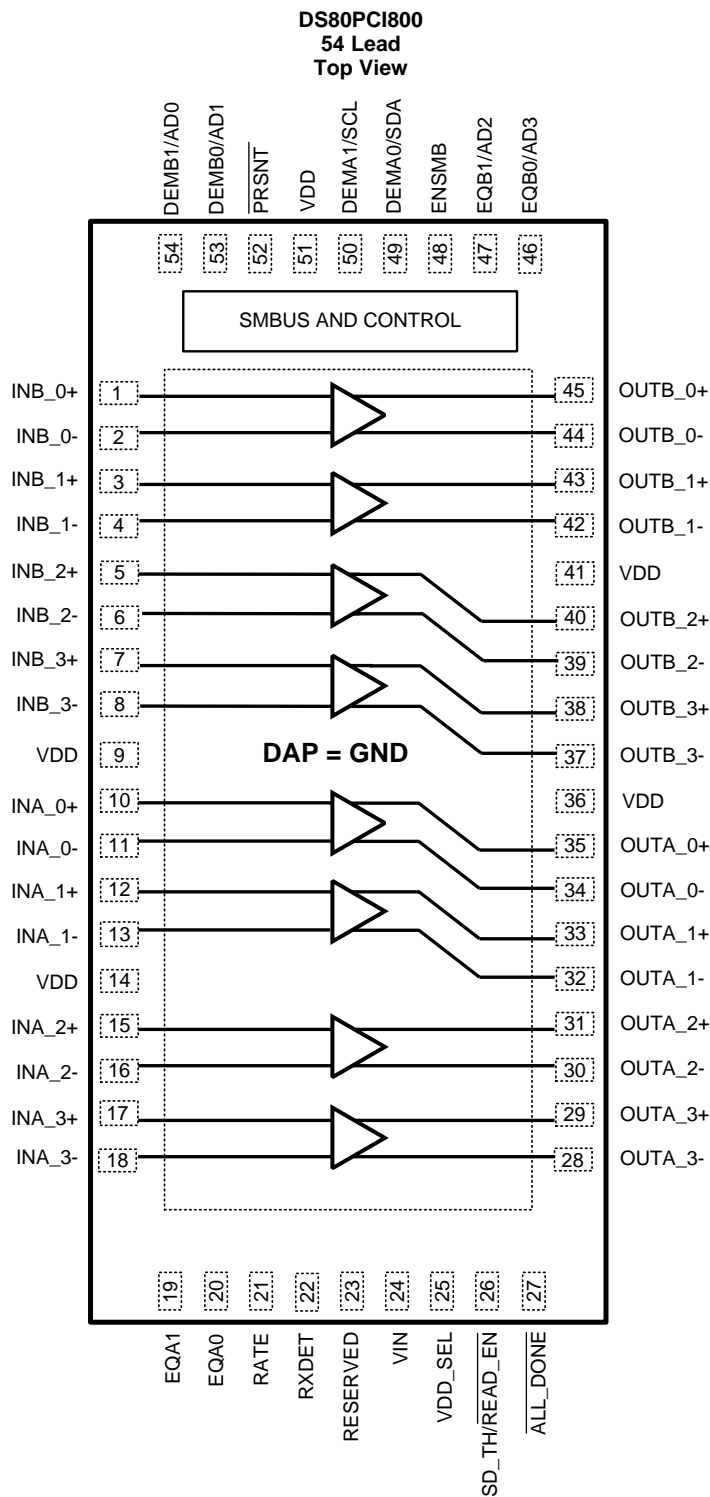

DS80PCI800

SNLS334G – APRIL 2011 – REVISED JANUARY 2015

www.ti.com

Pin Functions⁽¹⁾⁽²⁾⁽³⁾⁽⁴⁾

PIN		I/O, TYPE	DESCRIPTION
NAME	NO.		
DIFFERENTIAL HIGH SPEED I/Os			
INB_0+, INB_0-, INB_1+, INB_1-, INB_2+, INB_2-, INB_3+, INB_3-	1, 2, 3, 4, 5, 6, 7, 8	I, CML	Inverting and non-inverting differential inputs to bank B equalizer. A gated on-chip 50-Ω termination resistor connects INB_n+ to VDD and INB_n- to VDD depending on the state of RXDET. See Table 4 AC coupling required on high-speed I/O
INA_0+, INA_0-, INA_1+, INA_1-, INA_2+, INA_2-, INA_3+, INA_3-	10, 11, 12, 13, 15, 16, 17, 18	I, CML	Inverting and non-inverting differential inputs to bank A equalizer. A gated on-chip 50-Ω termination resistor connects INA_n+ to VDD and INA_n- to VDD depending on the state of RXDET. See Table 4 AC coupling required on high-speed I/O
OUTB_0+, OUTB_0-, OUTB_1+, OUTB_1-, OUTB_2+, OUTB_2-, OUTB_3+, OUTB_3-	45, 44, 43, 42, 40, 39, 38, 37	O, CML	Inverting and non-inverting 50-Ω driver bank B outputs with de-emphasis. Compatible with AC-coupled CML inputs.
OUTA_0+, OUTA_0-, OUTA_1+, OUTA_1-, OUTA_2+, OUTA_2-, OUTA_3+, OUTA_3-	35, 34, 33, 32, 31, 30, 29, 28	O, CML	Inverting and non-inverting 50-Ω driver bank A outputs with de-emphasis. Compatible with AC-coupled CML inputs.
CONTROL PINS — SHARED (LVCMOS)			
ENSMB	48	I, 4-LEVEL, LVCMOS	System management bus (SMBus) enable pin Tie 1 k to VDD (2.5-V mode) or VIN (3.3 V-mode) = Register access SMBus slave mode FLOAT = Read external EEPROM (master SMBUS mode) Tie 1 kΩ to GND = Pin mode
ENSMB = 1 (SMBus SLAVE MODE)			
SCL	50	I, 2-LEVEL, LVCMOS, O, open drain	In SMBus Slave Mode, this pin is the SMBus clock I/O. Clock input or open drain output. External 2-kΩ to 5-kΩ pullup resistor to VDD or VIN recommended as per SMBus interface standards. ⁽⁵⁾
SDA	49	I, 2-LEVEL, LVCMOS, O, open drain	In both SMBus Modes, this pin is the SMBus data I/O. Data input or open drain output. External 2-kΩ to 5-kΩ pullup resistor to VDD or VIN recommended as per SMBus interface standards. ⁽⁵⁾
AD0-AD3	54, 53, 47, 46	I, 4-LEVEL, LVCMOS	SMBus Slave Address Inputs. In both SMBus Modes, these pins are the user set SMBus slave address inputs. External 1-kΩ pullup or pulldown recommended.
READ_EN / SD_TH	26	I, FLOAT	In SMBus Slave Mode, this pin is not used. Leave it floating.
ENSMB = FLOAT (SMBus MASTER MODE)			
SCL	50	I, 2-LEVEL, LVCMOS, O, open drain	Clock output when loading EEPROM configuration, reverting to SMBus clock input when EEPROM load is complete (ALL_DONE = 0). External 2-kΩ to 5-kΩ pullup resistor to VDD or VIN recommended as per SMBus interface standards. ⁽⁵⁾
SDA	49	I, 2-LEVEL, LVCMOS, O, open drain	In both SMBus Modes, this pin is the SMBus data I/O. Data input or open drain output. External 2-kΩ to 5-kΩ pullup resistor to VDD or VIN recommended as per SMBus interface standards. ⁽⁵⁾
AD0-AD3	54, 53, 47, 46	I, 4-LEVEL, LVCMOS	SMBus Slave Address Inputs. In both SMBus Modes, these pins are the user set SMBus slave address inputs. External 1-kΩ pullup or pulldown recommended.
READ_EN	26	I, 2-LEVEL, LVCMOS	A logic low on this pin starts the load from the external EEPROM ⁽⁶⁾ Once EEPROM load is complete (ALL_DONE = 0), this pin functionality remains as READ_EN. It does not revert to an SD_TH input.

- (1) LVCMOS inputs without the “FLOAT” conditions must be driven to a logic low or high at all times or operation is not verified.
- (2) Input edge rate for LVCMOS/FLOAT inputs must be faster than 50 ns from 10% to 90%.
- (3) For 3.3-V mode operation, VIN pin = 3.3 V and the VDD for the 4-level input is 3.3 V.
- (4) For 2.5-V mode operation, VDD pin = 2.5 V and the VDD for the 4-level input is 2.5 V.
- (5) SCL and SDA pins can be tied either to 3.3 V or 2.5 V, regardless of whether the device is operating in 2.5-V mode or 3.3-V mode.
- (6) When READ_EN is asserted low, the device attempts to load EEPROM. If EEPROM cannot be loaded successfully, for example due to an invalid or blank hex file, the DS80PCI800 waits indefinitely in an unknown state where SMBus access is not possible. ALL_DONE pin remains high in this situation.

Pin Functions⁽¹⁾⁽²⁾⁽³⁾⁽⁴⁾ (continued)

PIN		I/O, TYPE	DESCRIPTION
NAME	NO.		
$\overline{\text{ALL_DONE}}$	27	O, 2-LEVEL, LVCMOS	Valid register load status output HIGH = External EEPROM load failed or incomplete LOW = External EEPROM load passed
ENSMB = 0 (PIN MODE)			
EQA0, EQA1, EQB0, EQB1	20, 19, 46, 47	I, 4-LEVEL, LVCMOS	EQA[1:0] and EQB[1:0] control the level of equalization on the input pins. The pins are active only when ENSMB is deasserted (low). The 8 channels are organized into two banks. Bank A is controlled with the EQA[1:0] pins and bank B is controlled with the EQB[1:0] pins. When ENSMB goes high the SMBus registers provide independent control of each channel. The EQB[1:0] pins are converted to SMBUS AD2/AD3 inputs. See Table 2 .
DEMA0, DEMA1, DEMB0, DEMB1	49, 50, 53, 54	I, 4-LEVEL, LVCMOS	DEMA[1:0] and DEMB[1:0] control the level of de-emphasis of the output driver. The pins are only active when ENSMB is deasserted (low). The 8 channels are organized into two banks. Bank A is controlled with the DEMA[1:0] pins and bank B is controlled with the DEMB[1:0] pins. When ENSMB goes high the SMBus registers provide independent control of each channel. The DEMA[1:0] pins are converted to SMBUS SCL/SDA and DEMB[1:0] pins are converted to AD0, AD1 inputs. See Table 3 .
CONTROL PINS — BOTH PIN AND SMBUS MODES (LVCMOS)			
RATE	21	I, 4-LEVEL, LVCMOS	RATE control pin selects GEN 1,2 and GEN 3 operating modes. Tie 1 k Ω to GND = GEN 1,2 FLOAT = AUTO Rate Select of Gen1/2 and Gen3 with de-emphasis Tie 20 k Ω to GND = GEN 3 without de-emphasis Tied 1 k Ω to VDD = RESERVED
RXDET	22	I, 4-LEVEL, LVCMOS	The RXDET pin controls the receiver detect function. Depending on the input level, a 50 Ω or > 50 k Ω termination to the power rail is enabled. See Table 4 .
RESERVED	23	I, FLOAT	Float (leave pin open) = Normal Operation
VDD_SEL	25	I, LVCMOS	Controls the internal regulator FLOAT = 2.5-V mode Tie GND = 3.3-V mode See Figure 14
SD_TH	26	I, 4-LEVEL, LVCMOS	Controls the internal Signal Detect Threshold. See Table 5 .
$\overline{\text{PRSNT}}$	52	I, 2-LEVEL, LVCMOS	Cable Present Detect input. High when a cable is not present per PCIe Cabling Spec. 1.0. Puts part into low power mode. When LOW (normal operation) part is enabled. See Table 4 .
POWER			
VIN	24	Power	In 3.3-V mode, feed 3.3 V to VIN In 2.5-V mode, leave floating
VDD	9, 14, 36, 41, 51	Power	Power supply pins 2.5-V mode, connect to 2.5-V supply 3.3-V mode, connect 0.1- μ F capacitor to each VDD pin (output of LDO)
GND	DAP	Power	Ground pad (DAP - die attach pad)

DS80PCI800

SNLS334G – APRIL 2011 – REVISED JANUARY 2015

www.ti.com

6 Specifications**6.1 Absolute Maximum Ratings**⁽¹⁾⁽²⁾⁽³⁾

	MIN	MAX	UNIT
Supply voltage (VDD - 2.5-V mode)	-0.5	2.75	V
Supply voltage (VIN - 3.3-V mode)	-0.5	4.0	V
LVC MOS input/output voltage	-0.5	4.0	V
CML input voltage	-0.5	VDD + 0.5	V
CML input current	-30	30	mA
Junction temperature		125	°C
Lead temperature soldering (4 s) ⁽⁴⁾		260	°C
Storage temperature, T _{stg}	-40	125	°C

- (1) Stresses beyond those listed under *Absolute Maximum Ratings* may cause permanent damage to the device. These are stress ratings only, which do not imply functional operation of the device at these or any other conditions beyond those indicated under *Recommended Operating Ratings*. Exposure to absolute-maximum-rated conditions for extended periods may affect device reliability.
- (2) Maximum Numbers are specified for a junction temperature range of -40°C to 125°C. Models are validated to Maximum Operating Voltages only.
- (3) If Military/Aerospace specified devices are required, contact the Texas Instruments Sales Office/ Distributors for availability and specifications.
- (4) For soldering specifications: See application note [SNOA549](#).

6.2 ESD Ratings

		MAX	UNIT
V _(ESD)	Electrostatic discharge		
	Human body model (HBM), per ANSI/ESDA/JEDEC JS-001, all pins ⁽¹⁾	±3000	V
	Charged device model (CDM), per JEDEC specification JESD22-C101, all pins ⁽²⁾	±1000	
Machine model (MM), per JEDEC specification JESD22-A115-A	±200		

- (1) JEDEC document JEP155 states that 500-V HBM allows safe manufacturing with a standard ESD control process.
- (2) JEDEC document JEP157 states that 250-V CDM allows safe manufacturing with a standard ESD control process.

6.3 Recommended Operating Ratings

	MIN	NOM	MAX	UNIT
Supply voltage (2.5-V mode)	2.375	2.5	2.625	V
Supply voltage (3.3-V mode)	3.0	3.3	3.6	V
Ambient temperature	-40	25	85	°C
SMBus (SDA, SCL)			3.6	V
Supply noise up to 50 MHz ⁽¹⁾			100	mVp-p

- (1) Allowed supply noise (mVp-p sine wave) under typical conditions.

6.4 Electrical Characteristics

PARAMETER		TEST CONDITIONS	MIN	TYP	MAX	UNIT
POWER						
PD	Power Dissipation	VDD = 2.5 V supply, EQ Enabled, VOD = 1.0 V _{p-p} , RXDET = 1, PRSNT = 0		500	700	mW
		VIN = 3.3 V supply, EQ Enabled, VOD = 1.0 V _{p-p} , RXDET = 1, PRSNT = 0		660	900	mW
LVC MOS / LV TTL DC SPECIFICATIONS						
V _{IH25}	High-level input voltage (PRSNT, READ_EN pins)	2.5-V Mode	2.0		VDD	V
V _{IH33}	High-level input voltage (PRSNT, READ_EN pins)	3.3-V Mode	2.0		VIN	V
V _{IL}	Low-Level Input Voltage (PRSNT, READ_EN pins)		0		0.8	V
V _{OH}	High-level output voltage (ALL_DONE pin)	I _{OH} = -4 mA	2.0			V
V _{OL}	Low-level output voltage (ALL_DONE pin)	I _{OL} = 4 mA			0.4	V
I _{IH}	Input high current (PRSNT pin)	VIN = 3.6 V, LVCMOS = 3.6 V	-15		15	μA
	Input high current with internal resistors (4-level input pin)		20		150	μA
I _{IL}	Input low current (PRSNT pin)	VIN = 3.6 V, LVCMOS = 0 V	-15		15	μA
	Input low current with internal resistors (4-level input pin)		-160		-40	μA
CML RECEIVER INPUTS (IN_{n+}, IN_{n-})						
RL _{RX-DIFF}	RX differential return loss	0.05 to 1.25 GHz		-16		dB
		1.25 to 2.5 GHz		-16		dB
		2.5 to 4.0 GHz		-14		dB
RL _{RX-CM}	RX common mode return loss	0.05 to 2.5 GHz		-12		dB
		2.5 to 4.0 GHz		-8		dB
Z _{RX-DC}	RX DC single-ended impedance	Tested at VDD = 2.5 V	40	50	60	Ω
Z _{RX-DIFF-DC}	RX DC differential mode impedance	Tested at VDD = 2.5 V	80	100	120	Ω
Z _{RX-HIGH-IMP-DC-POS}	DC input common mode impedance for V > 0	VID = 0 to 200 mV, ENSMB = 0, RXDET = 0, VDD = 2.5 V		50		kΩ
V _{RX-DIFF-DC}	Differential RX peak-to-peak voltage (VID)	Tested at pins			1.2	V
V _{RX-SIGNAL-DET-DIFF-PP}	Signal detect assert level for active data signal	SD_TH = float, 0101 pattern at 8 Gbps Measured at pins		180		mV _{p-p}
V _{RX-IDLE-DET-DIFF-PP}	Signal detect deassert level for electrical idle	SD_TH = float, 0101 pattern at 8 Gbps Measured at pins		110		mV _{p-p}

DS80PCI800

SNLS334G – APRIL 2011 – REVISED JANUARY 2015

www.ti.com

Electrical Characteristics (continued)

PARAMETER		TEST CONDITIONS	MIN	TYP	MAX	UNIT
HIGH-SPEED OUTPUTS						
$V_{TX-DIFF-PP}$	Output voltage differential swing	Differential measurement with OUT_n+ and OUT_n-, terminated by 50 Ω to GND, AC-Coupled, VID = 1.0 Vp-p, DEM0 = 1, DEM1 = 0 ⁽¹⁾	0.8	1.0	1.2	Vp-p
$V_{TX-DE-RATIO_3.5}$	TX de-emphasis ratio	VOD = 1.0 Vp-p, DEM0 = 0, DEM1 = R Gen 1 & 2 modes only		-3.5		dB
$V_{TX-DE-RATIO_6}$	TX de-emphasis ratio	VOD = 1.0 Vp-p, DEM0 = R, DEM1 = R Gen 1 & 2 modes only		-6		dB
t_{TX-DJ}	Deterministic Jitter	VID = 800 mV, PRBS15 pattern, 8.0 Gbps, VOD = 1.0 V, EQ = 0x00, DE = 0 dB (no input or output trace loss)		0.05		Upp
t_{TX-RJ}	Random Jitter	VID = 800 mV, 0101 pattern, 8.0 Gbps, VOD = 1.0 V, EQ = 0x00, DE = 0 dB, (no input or output trace loss)		0.3		ps RMS
$t_{TX-RISE-FALL}$	TX rise/fall time	20% to 80% of differential output voltage ⁽²⁾	35	45		ps
$t_{RF-MISMATCH}$	TX rise/fall mismatch	20% to 80% of differential output voltage ⁽²⁾		0.01	0.1	UI
$RL_{TX-DIFF}$	TX differential return loss	0.05 to 1.25 GHz		-16		dB
		1.25 to 2.5 GHz		-12		dB
		2.5 to 4 GHz		-11		dB
RL_{TX-CM}	TX common mode return loss	0.05 to 2.5 GHz		-12		dB
		2.5 to 4 GHz		-8		dB
$Z_{TX-DIFF-DC}$	DC differential TX impedance			100		Ω
$V_{TX-CM-AC-PP}$	TX AC peak-peak common mode voltage	VOD = 1.0 Vp-p, DEM0 = 1, DEM1 = 0 ⁽²⁾			100	mVp-p
$I_{TX-SHORT}$	TX short circuit current limit	Total current the transmitter can supply when shorted to VDD or GND		20		mA
$V_{TX-CM-DC-ACTIVE-IDLE-DELTA}$	Absolute delta of DC common mode voltage during L0 and electrical idle	⁽²⁾			100	mV
$V_{TX-CM-DC-LINE-DELTA}$	Absolute delta of DC common mode voltage between TX+ and TX-	⁽²⁾			25	mV
$t_{TX-IDLE-DATA}$	Max time to transition to differential DATA signal after IDLE	VID = 1.0 Vp-p, 8 Gbps		3.5		ns
$t_{TX-DATA-IDLE}$	Max time to transition to IDLE after differential DATA signal	VID = 1.0 Vp-p, 8 Gbps		6.2		ns
$t_{PLHD/PHLD}$	High-to-low and low-to-high differential propagation delay	EQ = 0x00 ⁽³⁾		200		ps
t_{LSK}	Lane-to-lane skew	T = 25°C, VDD = 2.5 V		25		ps
t_{PPSK}	Part-to-part propagation delay skew	T = 25°C, VDD = 2.5 V		40		ps

- (1) In GEN3 mode, the output VOD level is not fixed. It will be adjusted automatically based on the VID input amplitude level. The output VOD level set by DEMA/B[1:0] in GEN3 mode is dependent on the VID level and the frequency content. The DS80PCI800 repeater in GEN3 mode is designed to be transparent, so the TX-FIR (de-emphasis) is passed to the RX to support the PCIe GEN3 handshake negotiation link training.
- (2) Parameter is characterized but not tested in production.
- (3) Propagation delay measurements will change slightly based on the level of EQ selected. EQ = 0x00 will result in the largest propagation delays.

Electrical Characteristics (continued)

PARAMETER		TEST CONDITIONS	MIN	TYP	MAX	UNIT
EQUALIZATION						
DJE1	Residual deterministic jitter at 8 Gbps	35" 4mils FR4, VID = 0.8 Vp-p, PRBS15, EQ = 0x1F , DEM = 0 dB		0.14		Upp
DJE2	Residual deterministic jitter at 5 Gbps	35" 4mils FR4, VID = 0.8 Vp-p, PRBS15, EQ = 0x1F , DEM = 0 dB		0.1		Upp
DJE3	Residual deterministic jitter at 2.5 Gbps	35" 4mils FR4, VID = 0.8 Vp-p, PRBS15, EQ = 0x1F , DEM = 0 dB		0.05		Upp
DJE4	Residual deterministic jitter at 8 Gbps	10 meters 30-awg cable, VID = 0.8 Vp-p, PRBS15, EQ = 0x2F , DEM = 0 dB		0.16		Upp
DJE5	Residual deterministic jitter at 5 Gbps	10 meters 30-awg cable, VID = 0.8 Vp-p, PRBS15, EQ = 0x2F , DEM = 0 dB		0.1		Upp
DJE6	Residual deterministic jitter at 2.5 Gbps	10 meters 30-awg cable, VID = 0.8 Vp-p, PRBS15, EQ = 0x2F , DEM = 0 dB		0.05		Upp
DE-EMPHASIS (GEN 1,2 MODE ONLY)						
DJD1	Residual deterministic jitter at 2.5 Gbps and 5.0 Gbps	10" 4mils FR4, VID = 0.8 Vp-p, PRBS15, EQ = 0x00, VOD = 1.0 Vp-p, DEM = -3.5 dB		0.1		Upp
DJD2	Residual deterministic jitter at 2.5 Gbps and 5.0 Gbps	20" 4mils FR4, VID = 0.8 Vp-p, PRBS15, EQ = 0x00, VOD = 1.0 Vp-p, DEM = -9 dB		0.1		Upp

DS80PCI800

SNLS334G – APRIL 2011 – REVISED JANUARY 2015

www.ti.com

6.5 Electrical Characteristics — Serial Management Bus Interface

Over recommended operating supply and temperature ranges unless other specified.

PARAMETER	TEST CONDITIONS	MIN	TYP	MAX	UNIT	
SERIAL BUS INTERFACE DC SPECIFICATIONS						
V _{IL}	Data, clock input low voltage			0.8	V	
V _{IH}	Data, clock input high voltage	2.1		3.6	V	
I _{PULLUP}	Current through pullup resistor or current source	High Power Specification		4	mA	
V _{DD}	Nominal bus voltage	2.375		3.6	V	
I _{LEAK-Bus}	Input leakage per bus segment	(1)		200	μA	
I _{LEAK-Pin}	Input leakage per device pin		-15		μA	
C _I	Capacitance for SDA and SCL	(1) (2)		10	pF	
R _{TERM}	External termination resistance pull to V _{DD} = 2.5 V ± 5% or 3.3 V ± 10%	Pullup V _{DD} = 3.3 V ⁽¹⁾ (2) (3)		2000	Ω	
		Pullup V _{DD} = 2.5 V ⁽¹⁾ (2) (3)		1000	Ω	
SERIAL BUS INTERFACE TIMING SPECIFICATIONS						
FSMB	Bus operating frequency	ENSMB = VDD (Slave Mode)		400	kHz	
		ENSMB = FLOAT (Master Mode)		280	400	520
t _{BUF}	Bus free time between stop and start condition			1.3	μs	
t _{HD:STA}	Hold time after (repeated) start condition. After this period, the first clock is generated.	At I _{PULLUP} , Max		0.6	μs	
t _{SU:STA}	Repeated start condition setup time			0.6	μs	
t _{SU:STO}	Stop condition setup time			0.6	μs	
t _{HD:DAT}	Data hold time			0	ns	
t _{SU:DAT}	Data setup time			100	ns	
t _{LOW}	Clock low period			1.3	μs	
t _{HIGH}	Clock high period	(4)		0.6	50	μs
t _F	Clock/data fall time	(4)			300	ns
t _R	Clock/data rise time	(4)			300	ns
t _{POR}	Time in which a device must be operational after power-on reset	(4) (5)			500	ms

(1) Recommended value.

(2) Recommended maximum capacitance load per bus segment is 400 pF.

(3) Maximum termination voltage should be identical to the device supply voltage.

(4) Compliant to SMBus 2.0 physical layer specification. See System Management Bus (SMBus) Specification Version 2.0, section 3.1.1 SMBus common AC specifications for details.

(5) Specified by design. Parameter not tested in production.

6.6 Typical Characteristics

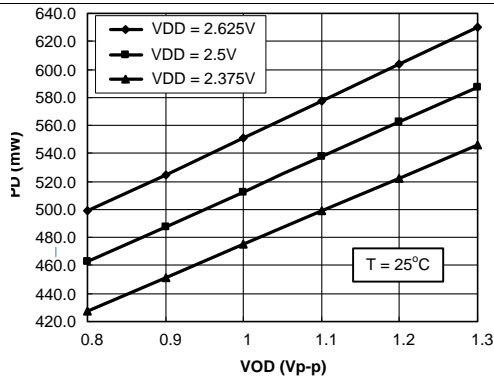

Figure 1. Power Dissipation (PD) vs Output Differential Voltage (VOD)

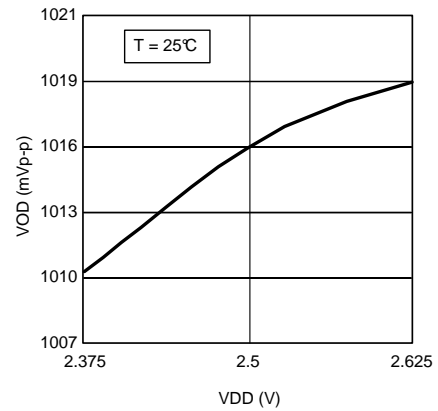

Figure 2. Output Differential Voltage (VOD = 1.0 Vp-p) vs Supply Voltage (VDD)

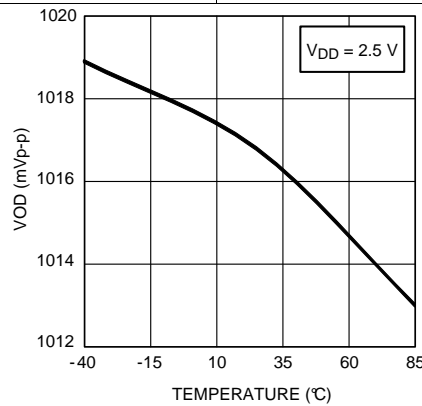

Figure 3. Output Differential Voltage (VOD = 1.0 Vp-p) vs Temperature

DS80PCI800

SNLS334G – APRIL 2011 – REVISED JANUARY 2015

www.ti.com

7 Parameter Measurement Information

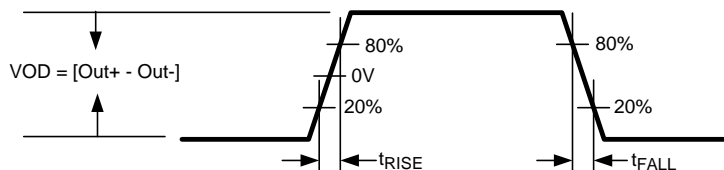

Figure 4. CML Output and Rise and Fall Transition Time

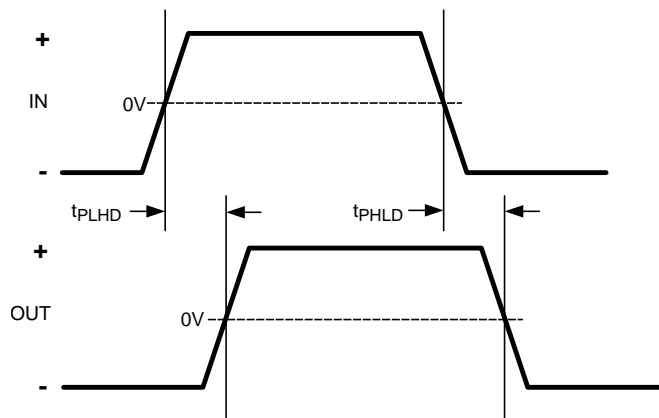

Figure 5. Propagation Delay Timing Diagram

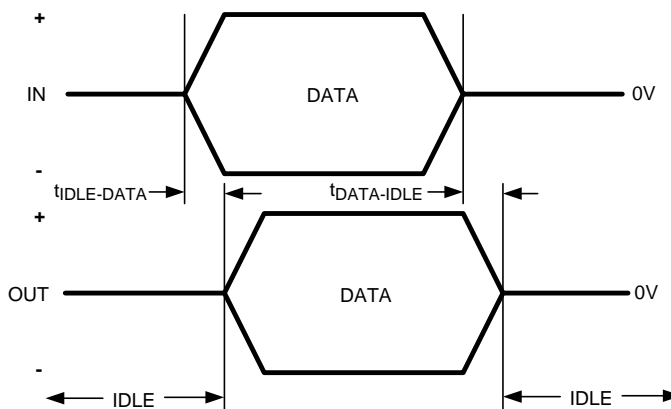

Figure 6. Transmit IDLE-DATA and DATA-IDLE Response Time

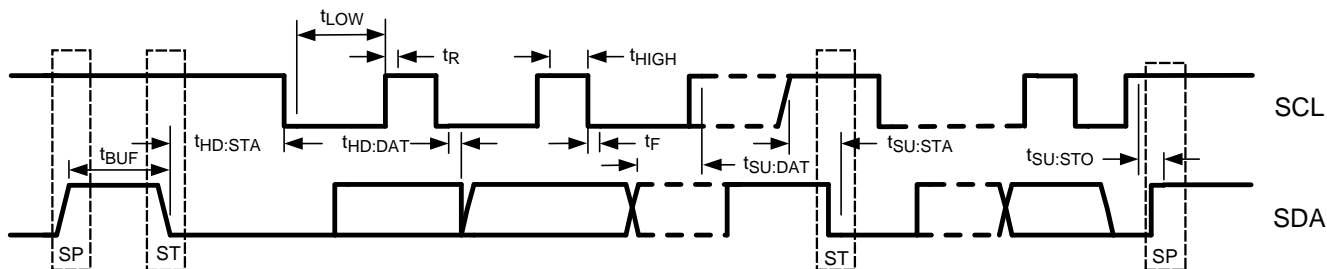

Figure 7. SMBus Timing Parameters

8 Detailed Description

8.1 Overview

The DS80PCI800 provides input CTLE and output De-emphasis equalization for lossy printed circuit board trace and cables. The DS80PCI800 operates in three modes: Pin Control Mode configuration (ENSMB = 0), SMBus Slave Mode (ENSMB = 1) for register configurations from host controller or SMBus Master Mode (ENSMB = Float) for loading the register configurations from an external EEPROM.

8.2 Functional Block Diagram

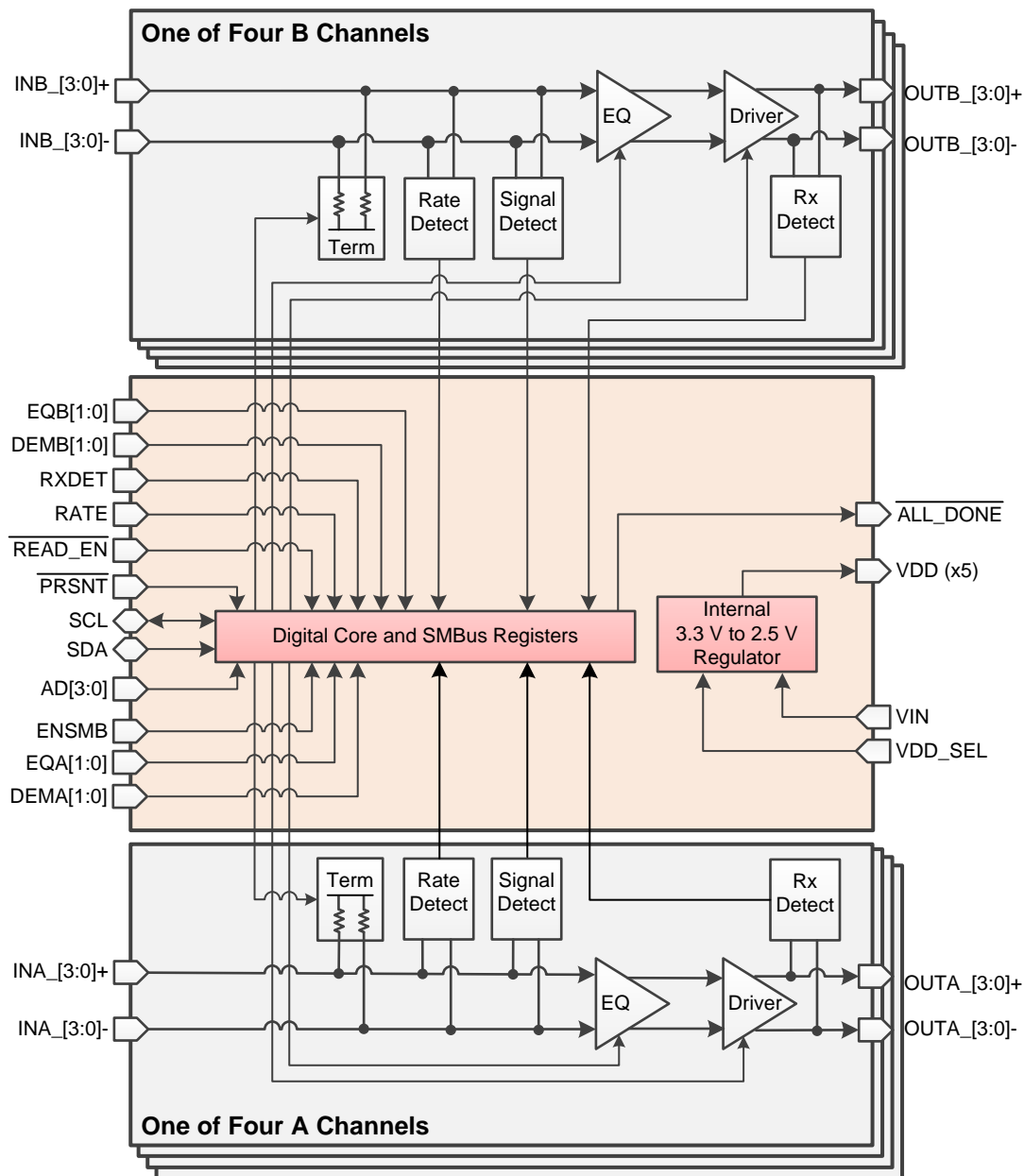

Note: This diagram is representative of device signal flow only.

DS80PCI800

SNLS334G – APRIL 2011 – REVISED JANUARY 2015

www.ti.com

8.3 Feature Description**8.3.1 4-Level Input Configuration Guidelines**

The 4-level input pins use a resistor divider to help set the four valid levels. There is an internal 30-k Ω pullup and a 60-k Ω pulldown connected to the package pin. These resistors, together with the external resistor connection combine to achieve the desired voltage level. Using the 1-k Ω pullup, 1-k Ω pulldown, no connect, or 20-k Ω pulldown provide the optimal voltage levels for each of the four input states.

Table 1. 4-Level Input Voltage

LEVEL	SETTING	3.3-V MODE	2.5-V MODE
0	1 k Ω to GND	0.1 V	0.08 V
R	20 k Ω to GND	$0.33 \times V_{IN}$	$0.33 \times V_{DD}$
F	FLOAT	$0.67 \times V_{IN}$	$0.67 \times V_{DD}$
1	1 k Ω to V_{DD}/V_{IN}	$V_{IN} - 0.05 V$	$V_{DD} - 0.04 V$

Typical 4-level input thresholds:

- Level 1 to 2 = $0.2 V_{IN}$ or V_{DD}
- Level 2 to 3 = $0.5 V_{IN}$ or V_{DD}
- Level 3 to 4 = $0.8 V_{IN}$ or V_{DD}

To minimize the start-up current associated with the integrated 2.5 V regulator, the 1-k Ω pullup and pulldown resistors are recommended. If several 4-level inputs require the same setting, it is possible to combine two or more 1-k Ω resistors into a single lower value resistor. As an example; combining two inputs with a single 500- Ω resistor is a good way to save board space. For the 20 k Ω to GND, this should also scale to 10 k Ω .

Table 2. Equalizer Settings⁽¹⁾

EQUALIZATION BOOST RELATIVE TO DC							
LEVEL	EQA1 EQB1	EQA0 EQB0	EQ – 8 BITS [7:0]	dB at 1.25 GHz	dB at 2.5 GHz	dB at 4 GHz	SUGGESTED USE
1	0	0	0000 0000 = 0x00	2.1	3.7	4.9	FR4 < 5 inch trace
2	0	R	0000 0001 = 0x01	3.4	5.8	7.9	FR4 5 inch 5–mil trace
3	0	Float	0000 0010 = 0x02	4.8	7.7	9.9	FR4 5 inch 4–mil trace
4	0	1	0000 0011 = 0x03	5.9	8.9	11.0	FR4 10 inch 5–mil trace
5	R	0	0000 0111 = 0x07	7.2	11.2	14.3	FR4 10 inch 4–mil trace
6	R	R	0001 0101 = 0x15	6.1	11.4	14.6	FR4 15 inch 4–mil trace
7	R	Float	0000 1011 = 0x0B	8.8	13.5	17.0	FR4 20 inch 4–mil trace
8	R	1	0000 1111 = 0x0F	10.2	15.0	18.5	FR4 25 to 30 inch 4–mil trace
9	Float	0	0101 0101 = 0x55	7.5	12.8	18.0	FR4 30 inch 4–mil trace
10	Float	R	0001 1111 = 0x1F	11.4	17.4	22.0	FR4 35 inch 4–mil trace
11	Float	Float	0010 1111 = 0x2F	13.0	19.7	24.4	10 m, 30-awg cable
12	Float	1	0011 1111 = 0x3F	14.2	21.1	25.8	10 m – 12m cable
13	1	0	1010 1010 = 0xAA	13.8	21.7	27.4	
14	1	R	0111 1111 = 0x7F	15.6	23.5	29.0	
15	1	Float	1011 1111 = 0xBF	17.2	25.8	31.4	
16	1	1	1111 1111 = 0xFF	18.4	27.3	32.7	

(1) The suggested equalizer CTLE settings are based on 0 dB of TX preshoot/de-emphasis. In PCIe Gen 3 applications which use TX preshoot/de-emphasis, the CTLE should be set to a lower boost setting to optimize the RX eye opening.

Table 3. Output Voltage and De-Emphasis Settings⁽¹⁾

LEVEL	DEMA1 DEMB1	DEMA0 DEMB0	VOD Vp-p	DEM dB ⁽¹⁾	INNER AMPLITUDE Vp-p	SUGGESTED USE
1	0	0	0.8	0	0.8	FR4 < 5 inch 4-mil trace
2	0	R	0.9	0	0.9	FR4 < 5 inch 4-mil trace
3	0	Float	0.9	-3.5	0.6	FR4 10 inch 4-mil trace
4	0	1	1.0	0	1.0	FR4 < 5 inch 4-mil trace
5	R	0	1.0	-3.5	0.7	FR4 10 inch 4-mil trace
6	R	R	1.0	-6	0.5	FR4 15 inch 4-mil trace
7	R	Float	1.1	0	1.1	FR4 < 5 inch 4-mil trace
8	R	1	1.1	-3.5	0.7	FR4 10 inch 4-mil trace
9	Float	0	1.1	-6	0.6	FR4 15 inch 4-mil trace
10	Float	R	1.2	0	1.2	FR4 < 5 inch 4-mil trace
11	Float	Float	1.2	-3.5	0.8	FR4 10 inch 4-mil trace
12	Float	1	1.2	-6	0.6	FR4 15 inch 4-mil trace
13	1	0	1.3	0	1.3	FR4 < 5 inch 4-mil trace
14	1	R	1.3	-3.5	0.9	FR4 10 inch 4-mil trace
15	1	Float	1.3	-6	0.7	FR4 15 inch 4-mil trace
16	1	1	1.3	-9	0.5	FR4 20 inch 4-mil trace

- (1) The VOD output amplitude and DEM de-emphasis levels are set with the DEMA/B[1:0] pins. The de-emphasis levels are available in GEN1, GEN2, and GEN 3 modes when RATE = Float.

Table 4. RX-Detect Settings

PRSN ⁽¹⁾ (PIN 52)	RXDET (PIN 22)	SMBus REG BIT[3:2]	INPUT TERMINATION	COMMENTS
0	0	00	Hi-Z	Manual RX-Detect, input is high-impedance mode
0	Tie 20 kΩ to GND	01	Pre Detect: Hi-Z Post Detect: 50 Ω	Auto RX-Detect, outputs test every 12 ms for 600 ms then stops; termination is hi-Z until detection; once detected input termination is 50 Ω Reset function by pulsing PRSN high for 5 μs then low again
0	Float (Default)	10	Pre Detect: Hi-Z Post Detect: 50 Ω	Auto RX-Detect, outputs test every 12 ms until detection occurs; termination is hi-Z until detection; once detected input termination is 50 Ω Reset function by pulsing PRSN high for 5 μs then low again
0	1	11	50 Ω	Manual RX-Detect, input is 50 Ω
1	X		Hi-Z	Power-down mode, input is high impedance, output drivers are disabled Used to reset RX-Detect State Machine when held high for 5 μs

- (1) In SMBus Slave Mode, the Rx Detect State Machine can be manually reset in software by overriding the device PRSN function. This is accomplished by setting the Override RXDET bit (Reg 0x02[7]) and then toggling the RXDET Value bit (Reg 0x02[6]). See Table 9 for more information about resetting the Rx Detect State Machine.

DS80PCI800

SNLS334G – APRIL 2011 – REVISED JANUARY 2015

www.ti.com

Table 5. Signal Detect Threshold Level⁽¹⁾

SD_TH	SMBus REG BIT [3:2] AND [1:0]	ASSERT LEVEL (TYP)	DEASSERT LEVEL (TYP)
0	10	210 mVp-p	150 mVp-p
R	01	160 mVp-p	100 mVp-p
F (default)	00	180 mVp-p	110 mVp-p
1	11	190 mVp-p	130 mVp-p

(1) VDD = 2.5 V, 25°C, and 0101 pattern at 8 Gbps.

8.4 Device Functional Modes

The DS80PCI800 is a low-power 8-channel repeater optimized for PCI Express Gen 1/2 and 3. The DS80PCI800 compensates for lossy FR-4 printed circuit board backplanes and balanced cables. The DS80PCI800 operates in three modes: Pin Control Mode (ENSMB = 0), SMBus Slave Mode (ENSMB = 1) and SMBus Master Mode (ENSMB = float) to load register information from external EEPROM; refer to [SMBus Master Mode](#) for additional information.

8.4.1 Pin Control Mode

When in pin mode (ENSMB = 0), equalization and de-emphasis can be selected via pin for each side independently. When de-emphasis is asserted VOD is automatically adjusted per the De-Emphasis table below. The RXDET pins provides automatic and manual control for input termination (50 Ω or > 50 kΩ). RATE setting is also pin controllable with pin selections (Gen 1/2, auto detect and Gen 3). The receiver electrical idle detect threshold is also adjustable via the SD_TH pin.

8.4.2 SMBUS Mode

When in SMBus mode (ENSMB = 1), the VOD (output amplitude), equalization, de-emphasis, and termination disable features are all programmable on a individual lane basis, instead of grouped by A or B as in the pin mode case. Upon assertion of ENSMB, the EQx and DEMx functions revert to register control immediately. The EQx and DEMx pins are converted to AD0-AD3 SMBus address inputs. The other external control pins (RATE, RXDET and SD_TH) remain active unless their respective registers are written to and the appropriate override bit is set, in which case they are ignored until ENSMB is driven low (pin mode). On power-up and when ENSMB is driven low all registers are reset to their default state. If PRSNT is asserted while ENSMB is high, the registers retain their current state.

Equalization settings accessible via the pin controls were chosen to meet the needs of most PCIe applications. If additional fine tuning or adjustment is needed, additional equalization settings can be accessed via the SMBus registers. Each input has a total of 256 possible equalization settings. The [4-Level Input Configuration Guidelines](#) show the 16 setting when the device is in pin mode. When using SMBus mode, the equalization, VOD and de-emphasis levels are set by registers.

8.5 Programming**8.5.1 System Management Bus (SMBus) and Configuration Registers**

The System Management Bus interface is compatible to SMBus 2.0 physical layer specification. ENSMB = 1 kΩ to VDD to enable SMBus slave mode and allow access to the configuration registers.

The DS80PCI800 has the AD[3:0] inputs in SMBus mode. These pins are the user set SMBUS slave address inputs. The AD[3:0] pins have internal pulldown. When left floating or pulled low the AD[3:0] = 0000'b, the device default address byte is 0xB0. Based on the SMBus 2.0 specification, the DS80PCI800 has a 7-bit slave address. The LSB is set to 0'b (for a WRITE). The device supports up to 16 address byte, which can be set with the AD[3:0] inputs. Below are the 16 addresses.

Programming (continued)

Table 6. Device Slave Address Bytes

AD[3:0] SETTINGS	ADDRESS BYTES (HEX)	7-BIT SLAVE ADDRESS (HEX)
0000	B0	58
0001	B2	59
0010	B4	5A
0011	B6	5B
0100	B8	5C
0101	BA	5D
0110	BC	5E
0111	BE	5F
1000	C0	60
1001	C2	61
1010	C4	62
1011	C6	63
1100	C8	64
1101	CA	65
1110	CC	66
1111	CE	67

The SDA/SCL pins are 3.3 V tolerant, but are not 5 V tolerant. An external pullup resistor is required on the SDA and SCL line. The resistor value can be from 2 kΩ to 5 kΩ depending on the voltage, loading, and speed.

8.5.2 Transfer of Data Through the SMBus

During normal operation the data on SDA must be stable during the time when SCL is High.

There are three unique states for the SMBus:

START: A high-to-low transition on SDA while SCL is High indicates a message START condition.

STOP: A low-to-high transition on SDA while SCL is High indicates a message STOP condition.

IDLE: If SCL and SDA are both High for a time exceeding t_{BUF} from the last detected STOP condition or if they are High for a total exceeding the maximum specification for t_{HIGH} then the bus will transfer to the IDLE state.

8.5.3 Writing a Register

To write a register, the following protocol is used (see SMBus 2.0 specification).

1. The Host drives a START condition, the 7-bit SMBus address, and a "0" indicating a WRITE.
2. The Device (Slave) drives the ACK bit ("0").
3. The Host drives the 8-bit Register Address.
4. The Device drives an ACK bit ("0").
5. The Host drive the 8-bit data byte.
6. The Device drives an ACK bit ("0").
7. The Host drives a STOP condition.

The WRITE transaction is completed, the bus goes IDLE and communication with other SMBus devices may now occur.

DS80PCI800

SNLS334G – APRIL 2011 – REVISED JANUARY 2015

www.ti.com

8.5.4 Reading a Register

To read a register, the following protocol is used (see SMBus 2.0 specification).

1. The Host drives a START condition, the 7-bit SMBus address, and a “0” indicating a WRITE.
2. The Device (Slave) drives the ACK bit (“0”).
3. The Host drives the 8-bit Register Address.
4. The Device drives an ACK bit (“0”).
5. The Host drives a START condition.
6. The Host drives the 7-bit SMBus Address, and a “1” indicating a READ.
7. The Device drives an ACK bit “0”.
8. The Device drives the 8-bit data value (register contents).
9. The Host drives a NACK bit “1” indicating end of the READ transfer.
10. The Host drives a STOP condition.

The READ transaction is completed, the bus goes IDLE and communication with other SMBus devices may now occur.

8.5.5 SMBus Master Mode

The DS80PCI800 device supports reading directly from an external EEPROM device by implementing SMBus Master mode. When using the SMBus master mode, the DS80PCI800 will read directly from specific location in the external EEPROM. When designing a system for using the external EEPROM, the user needs to follow these specific guidelines.

- Set ENSMB = Float — enable the SMBUS master mode.
- The external EEPROM device address byte must be 0xA0 and capable of 1 MHz operation at 2.5 V and 3.3 V supply. The maximum allowed size is 8 kbits (1024 bytes).
- Set the AD[3:0] inputs for SMBus address byte. When the AD[3:0] = 0000'b, the device address byte is 0xB0.

When tying multiple DS80PCI800 devices to the SDA and SCL bus, use these guidelines to configure the devices.

- Use SMBus AD[3:0] address bits so that each device can loaded its configuration from the EEPROM. Example below is for 4 devices.
 - U1: AD[3:0] = 0000 = 0xB0
 - U2: AD[3:0] = 0001 = 0xB2
 - U3: AD[3:0] = 0010 = 0xB4
 - U4: AD[3:0] = 0011 = 0xB6
- Use a pullup resistor on SDA and SCL; value = 2 kΩ
- Daisy-chain $\overline{\text{READ_EN}}$ (pin 26) and $\overline{\text{ALL_DONE}}$ (pin 27) from one device to the next device in the sequence so that they do not compete for the EEPROM at the same time.
 1. Tie $\overline{\text{READ_EN}}$ of the first device in the chain (U1) to GND
 2. Tie $\overline{\text{ALL_DONE}}$ of U1 to $\overline{\text{READ_EN}}$ of U2
 3. Tie $\overline{\text{ALL_DONE}}$ of U2 to $\overline{\text{READ_EN}}$ of U3
 4. Tie $\overline{\text{ALL_DONE}}$ of U3 to $\overline{\text{READ_EN}}$ of U4
 5. Optional: Tie $\overline{\text{ALL_DONE}}$ output of U4 to a LED to show the devices have been loaded successfully

DS80PCI800

SNLS334G – APRIL 2011 – REVISED JANUARY 2015

www.ti.com

8.6 Register Maps**Table 7. EEPROM Register Map - Single Device with Default Value**

EEPROM Address Byte		Bit 7	Bit 6	Bit 5	Bit 4	Bit 3	Bit 2	Bit 1	Bit 0
Description	0x00	CRC EN	Address Map Present	EEPROM > 256 Bytes	RES	DEVICE COUNT[3]	DEVICE COUNT[2]	DEVICE COUNT[1]	DEVICE COUNT[0]
Default Value		0	0	0	0	0	0	0	0
Description	0x01	RES	RES	RES	RES	RES	RES	RES	RES
Default Value		0	0	0	0	0	0	0	0
Description	0x02	Max EEPROM Burst size[7]	Max EEPROM Burst size[6]	Max EEPROM Burst size[5]	Max EEPROM Burst size[4]	Max EEPROM Burst size[3]	Max EEPROM Burst size[2]	Max EEPROM Burst size[1]	Max EEPROM Burst size[0]
Default Value		0	0	0	0	0	0	0	0
Description	0x03	PWDN_ch7	PWDN_ch6	PWDN_ch5	PWDN_ch4	PWDN_ch3	PWDN_ch2	PWDN_ch1	PWDN_ch0
SMBus Register		0x01[7]	0x01[6]	0x01[5]	0x01[4]	0x01[3]	0x01[2]	0x01[1]	0x01[0]
Default Value		0	0	0	0	0	0	0	0
Description	0x04	lpbk_1	lpbk_0	PWDN_INPUTS	PWDN_OSC	Ovrd_P $\overline{\text{RSNT}}$	RES	RES	RES
SMBus Register		0x02[5]	0x02[4]	0x02[3]	0x02[2]	0x02[0]	0x04[7]	0x04[6]	0x04[5]
Default Value		0	0	0	0	0	0	0	0
Description	0x05	RES	RES	RES	RES	RES	rxdet_btb_en	Ovrd_idle_th	Ovrd_RES
SMBus Register		0x04[4]	0x04[3]	0x04[2]	0x04[1]	0x04[0]	0x06[4]	0x08[6]	0x08[5]
Default Value		0	0	0	0	0	1	0	0
Description	0x06	Ovrd_IDLE	Ovrd_RX_DET	Ovrd_RATE	RES	RES	rx_delay_sel_2	rx_delay_sel_1	rx_delay_sel_0
SMBus Register		0x08[4]	0x08[3]	0x08[2]	0x08[1]	0x08[0]	0x0B[6]	0x0B[5]	0x0B[4]
Default Value		0	0	0	0	0	1	1	1
Description	0x07	RD_delay_sel_3	RD_delay_sel_2	RD_delay_sel_1	RD_delay_sel_0	ch0_Idle_auto	ch0_Idle_sel	ch0_RXDET_1	ch0_RXDET_0
SMBus Register		0x0B[3]	0x0B[2]	0x0B[1]	0x0B[0]	0x0E[5]	0x0E[4]	0x0E[3]	0x0E[2]
Default Value		0	0	0	0	0	0	0	0

Register Maps (continued)
Table 7. EEPROM Register Map - Single Device with Default Value (continued)

EEPROM Address Byte		Bit 7	Bit 6	Bit 5	Bit 4	Bit 3	Bit 2	Bit 1	Bit 0
Description	0x08	ch0_BST_7	ch0_BST_6	ch0_BST_5	ch0_BST_4	ch0_BST_3	ch0_BST_2	ch0_BST_1	ch0_BST_0
SMBus Register		0x0F[7]	0x0F[6]	0x0F[5]	0x0F[4]	0x0F[3]	0x0F[2]	0x0F[1]	0x0F[0]
Default Value		0x2F	0	0	1	0	1	1	1
Description	0x09	ch0_Sel_scp	ch0_Sel_mode	ch0_RES_2	ch0_RES_1	ch0_RES_0	ch0_VOD_2	ch0_VOD_1	ch0_VOD_0
SMBus Register		0x10[7]	0x10[6]	0x10[5]	0x10[4]	0x10[3]	0x10[2]	0x10[1]	0x10[0]
Default Value		0xAD	1	0	1	0	1	1	0
Description	0x0A	ch0_DEM_2	ch0_DEM_1	ch0_DEM_0	ch0_Slow	ch0_idle_tha_1	ch0_idle_tha_0	ch0_idle_thd_1	ch0_idle_thd_0
SMBus Register		0x11[2]	0x11[1]	0x11[0]	0x12[7]	0x12[3]	0x12[2]	0x12[1]	0x12[0]
Default Value		0x40	0	1	0	0	0	0	0
Description	0x0B	ch1_Idle_auto	ch1_Idle_sel	ch1_RXDET_1	ch1_RXDET_0	ch1_BST_7	ch1_BST_6	ch1_BST_5	ch1_BST_4
SMBus Register		0x15[5]	0x15[4]	0x15[3]	0x15[2]	0x16[7]	0x16[6]	0x16[5]	0x16[4]
Default Value		0x02	0	0	0	0	0	0	1
Description	0x0C	ch1_BST_3	ch1_BST_2	ch1_BST_1	ch1_BST_0	ch1_Sel_scp	ch1_Sel_mode	ch1_RES_2	ch1_RES_1
SMBus Register		0x16[3]	0x16[2]	0x16[1]	0x16[0]	0x17[7]	0x17[6]	0x17[5]	0x17[4]
Default Value		0xFA	1	1	1	1	1	0	1
Description	0x0D	ch1_RES_0	ch1_VOD_2	ch1_VOD_1	ch1_VOD_0	ch1_DEM_2	ch1_DEM_1	ch1_DEM_0	ch1_Slow
SMBus Register		0x17[3]	0x17[2]	0x17[1]	0x17[0]	0x18[2]	0x18[1]	0x18[0]	0x19[7]
Default Value		0xD4	1	1	0	1	0	1	0
Description	0x0E	ch1_idle_tha_1	ch1_idle_tha_0	ch1_idle_thd_1	ch1_idle_thd_0	ch2_Idle_auto	ch2_Idle_sel	ch2_RXDET_1	ch2_RXDET_0
SMBus Register		0x19[3]	0x19[2]	0x19[1]	0x19[0]	0x1C[5]	0x1C[4]	0x1C[3]	0x1C[2]
Default Value		0x00	0	0	0	0	0	0	0
Description	0x0F	ch2_BST_7	ch2_BST_6	ch2_BST_5	ch2_BST_4	ch2_BST_3	ch2_BST_2	ch2_BST_1	ch2_BST_0
SMBus Register		0x1D[7]	0x1D[6]	0x1D[5]	0x1D[4]	0x1D[3]	0x1D[2]	0x1D[1]	0x1D[0]
Default Value		0x2F	0	0	1	0	1	1	1

DS80PCI800

SNLS334G – APRIL 2011 – REVISED JANUARY 2015

www.ti.com

Register Maps (continued)**Table 7. EEPROM Register Map - Single Device with Default Value (continued)**

EEPROM Address Byte		Bit 7	Bit 6	Bit 5	Bit 4	Bit 3	Bit 2	Bit 1	Bit 0
Description	0x10	ch2_Sel_scp	ch2_Sel_mode	ch2_RES_2	ch2_RES_1	ch2_RES_0	ch2_VOD_2	ch2_VOD_1	ch2_VOD_0
SMBus Register		0x1E[7]	0x1E[6]	0x1E[5]	0x1E[4]	0x1E[3]	0x1E[2]	0x1E[1]	0x1E[0]
Default Value		0xAD	1	0	1	0	1	1	0
Description	0x11	ch2_DEM_2	ch2_DEM_1	ch2_DEM_0	ch2_Slow	ch2_idle_tha_1	ch2_idle_tha_0	ch2_idle_thd_1	ch2_idle_thd_0
SMBus Register		0x1F[2]	0x1F[1]	0x1F[0]	0x20[7]	0x20[3]	0x20[2]	0x20[1]	0x20[0]
Default Value		0x40	0	1	0	0	0	0	0
Description	0x12	ch3_Idle_auto	ch3_Idle_sel	ch3_RXDET_1	ch3_RXDET_0	ch3_BST_7	ch3_BST_6	ch3_BST_5	ch3_BST_4
SMBus Register		0x23[5]	0x23[4]	0x23[3]	0x23[2]	0x24[7]	0x24[6]	0x24[5]	0x24[4]
Default Value		0x02	0	0	0	0	0	0	1
Description	0x13	ch3_BST_3	ch3_BST_2	ch3_BST_1	ch3_BST_0	ch3_Sel_scp	ch3_Sel_mode	ch3_RES_2	ch3_RES_1
SMBus Register		0x24[3]	0x24[2]	0x24[1]	0x24[0]	0x25[7]	0x25[6]	0x25[5]	0x25[4]
Default Value		0xFA	1	1	1	1	1	0	1
Description	0x14	ch3_RES_0	ch3_VOD_2	ch3_VOD_1	ch3_VOD_0	ch3_DEM_2	ch3_DEM_1	ch3_DEM_0	ch3_Slow
SMBus Register		0x25[3]	0x25[2]	0x25[1]	0x25[0]	0x26[2]	0x26[1]	0x26[0]	0x27[7]
Default Value		0xD4	1	1	0	1	0	1	0
Description	0x15	ch3_idle_tha_1	ch3_idle_tha_0	ch3_idle_thd_1	ch3_idle_thd_0	ovrd_fast_idle	en_high_idle_th_n	en_high_idle_th_s	en_fast_idle_n
SMBus Register		0x27[3]	0x27[2]	0x27[1]	0x27[0]	0x28[6]	0x28[5]	0x28[4]	0x28[3]
Default Value		0x09	0	0	0	0	0	0	0
Description	0x16	en_fast_idle_s	eqsd_mgain_n	eqsd_mgain_s	ch4_Idle_auto	ch4_Idle_sel	ch4_RXDET_1	ch4_RXDET_0	ch4_BST_7
SMBus Register		0x28[2]	0x28[1]	0x28[0]	0x2B[5]	0x2B[4]	0x2B[3]	0x2B[2]	0x2C[7]
Default Value		0x80	1	0	0	0	0	0	0
Description	0x17	ch4_BST_6	ch4_BST_5	ch4_BST_4	ch4_BST_3	ch4_BST_2	ch4_BST_1	ch4_BST_0	ch4_Sel_scp
SMBus Register		0x2C[6]	0x2C[5]	0x2C[4]	0x2C[3]	0x2C[2]	0x2C[1]	0x2C[0]	0x2D[7]
Default Value		0x5F	0	1	0	1	1	1	1

Register Maps (continued)
Table 7. EEPROM Register Map - Single Device with Default Value (continued)

EEPROM Address Byte		Bit 7	Bit 6	Bit 5	Bit 4	Bit 3	Bit 2	Bit 1	Bit 0
Description	0x18	ch4_Sel_mode	ch4_RES_2	ch4_RES_1	ch4_RES_0	ch4_VOD_2	ch4_VOD_1	ch4_VOD_0	ch4_DEM_2
SMBus Register		0x2D[6]	0x2D[5]	0x2D[4]	0x2D[3]	0x2D[2]	0x2D[1]	0x2D[0]	0x2E[2]
Default Value		0x5A	0	1	0	1	1	0	1
Description	0x19	ch4_DEM_1	ch4_DEM_0	ch4_Slow	ch4_idle_tha_1	ch4_idle_tha_0	ch4_idle_thd_1	ch4_idle_thd_0	ch5_idle_auto
SMBus Register		0x2E[1]	0x2E[0]	0x2F[7]	0x2F[3]	0x2F[2]	0x2F[1]	0x2F[0]	0x32[5]
Default Value		0x80	1	0	0	0	0	0	0
Description	0x1A	ch5_Idle_sel	ch5_RXDET_1	ch5_RXDET_0	ch5_BST_7	ch5_BST_6	ch5_BST_5	ch5_BST_4	ch5_BST_3
SMBus Register		0x32[4]	0x32[3]	0x32[2]	0x33[7]	0x33[6]	0x33[5]	0x33[4]	0x33[3]
Default Value		0x05	0	0	0	0	0	1	0
Description	0x1B	ch5_BST_2	ch5_BST_1	ch5_BST_0	ch5_Sel_scp	ch5_Sel_mode	ch5_RES_2	ch5_RES_1	ch5_RES_0
SMBus Register		0x33[2]	0x33[1]	0x33[0]	0x34[7]	0x34[6]	0x34[5]	0x34[4]	0x34[3]
Default Value		0xF5	1	1	1	1	0	1	0
Description	0x1C	ch5_VOD_2	ch5_VOD_1	ch5_VOD_0	ch5_DEM_2	ch5_DEM_1	ch5_DEM_0	ch5_Slow	ch5_idle_tha_1
SMBus Register		0x34[2]	0x34[1]	0x34[0]	0x35[2]	0x35[1]	0x35[0]	0x36[7]	0x36[3]
Default Value		0xA8	1	0	1	0	1	0	0
Description	0x1D	ch5_idle_tha_0	ch5_idle_thd_1	ch5_idle_thd_0	ch6_Idle_auto	ch6_Idle_sel	ch6_RXDET_1	ch6_RXDET_0	ch6_BST_7
SMBus Register		0x36[2]	0x36[1]	0x36[0]	0x39[5]	0x39[4]	0x39[3]	0x39[2]	0x3A[7]
Default Value		0x00	0	0	0	0	0	0	0
Description	0x1E	ch6_BST_6	ch6_BST_5	ch6_BST_4	ch6_BST_3	ch6_BST_2	ch6_BST_1	ch6_BST_0	ch6_Sel_scp
SMBus Register		0x3A[6]	0x3A[5]	0x3A[4]	0x3A[3]	0x3A[2]	0x3A[1]	0x3A[0]	0x3B[7]
Default Value		0x5F	0	1	0	1	1	1	1
Description	0x1F	ch6_Sel_mode	ch6_RES_2	ch6_RES_1	ch6_RES_0	ch6_VOD_2	ch6_VOD_1	ch6_VOD_0	ch6_DEM_2
SMBus Register		0x3B[6]	0x3B[5]	0x3B[4]	0x3B[3]	0x3B[2]	0x3B[1]	0x3B[0]	0x3C[2]
Default Value		0x5A	0	1	0	1	1	0	1

DS80PCI800

SNLS334G – APRIL 2011 – REVISED JANUARY 2015

www.ti.com

Register Maps (continued)**Table 7. EEPROM Register Map - Single Device with Default Value (continued)**

EEPROM Address Byte		Bit 7	Bit 6	Bit 5	Bit 4	Bit 3	Bit 2	Bit 1	Bit 0
Description	0x20	ch6_DEM_1	ch6_DEM_0	ch6_Slow	ch6_idle_tha_1	ch6_idle_tha_0	ch6_idle_thd_1	ch6_idle_thd_0	ch7_idle_auto
SMBus Register		0x3C[1]	0x3C[0]	0x3D[7]	0x3D[3]	0x3D[2]	0x3D[1]	0x3D[0]	0x40[5]
Default Value		0x80	1	0	0	0	0	0	0
Description	0x21	ch7_idle_sel	ch7_RXDET_1	ch7_RXDET_0	ch7_BST_7	ch7_BST_6	ch7_BST_5	ch7_BST_4	ch7_BST_3
SMBus Register		0x40[4]	0x40[3]	0x40[2]	0x41[7]	0x41[6]	0x41[5]	0x41[4]	0x41[3]
Default Value		0x05	0	0	0	0	0	1	0
Description	0x22	ch7_BST_2	ch7_BST_1	ch7_BST_0	ch7_Sel_scp	ch7_Sel_mode	ch7_RES_2	ch7_RES_1	ch7_RES_0
SMBus Register		0x41[2]	0x41[1]	0x41[0]	0x42[7]	0x42[6]	0x42[5]	0x42[4]	0x42[3]
Default Value		0xF5	1	1	1	1	0	1	0
Description	0x23	ch7_VOD_2	ch7_VOD_1	ch7_VOD_0	ch7_DEM_2	ch7_DEM_1	ch7_DEM_0	ch7_Slow	ch7_idle_tha_1
SMBus Register		0x42[2]	0x42[1]	0x42[0]	0x43[2]	0x43[1]	0x43[0]	0x44[7]	0x44[3]
Default Value		0xA8	1	0	1	0	1	0	0
Description	0x24	ch7_idle_tha_0	ch7_idle_thd_1	ch7_idle_thd_0	iph_dac_ns_1	iph_dac_ns_0	ipp_dac_ns_1	ipp_dac_ns_0	ipp_dac_1
SMBus Register		0x44[2]	0x44[1]	0x44[0]	0x47[3]	0x47[2]	0x47[1]	0x47[0]	0x48[7]
Default Value		0x00	0	0	0	0	0	0	0
Description	0x25	ipp_dac_0	RD23_67	RD01_45	RD_PD_ovrd	RD_Sel_test	RD_RESET_ovrd	PWDB_input_DC	DEM_VOD_ovrd
SMBus Register		0x48[6]	0x4C[7]	0x4C[6]	0x4C[5]	0x4C[4]	0x4C[3]	0x4C[0]	0x59[0]
Default Value		0x00	0	0	0	0	0	0	0
Description	0x26	DEM_ovrd_N2	DEM_ovrd_N1	DEM_ovrd_N0	VOD_ovrd_N2	VOD_ovrd_N1	VOD_ovrd_N0	SPARE0	SPARE1
SMBus Register		0x5A[7]	0x5A[6]	0x5A[5]	0x5A[4]	0x5A[3]	0x5A[2]	0x5A[1]	0x5A[0]
Default Value		0x54	0	1	0	1	0	1	0
Description	0x27	DEM_ovrd_S2	DEM_ovrd_S1	DEM_ovrd_S0	VOD_ovrd_S2	VOD_ovrd_S1	VOD_ovrd_S0	SPARE0	SPARE1
SMBus Register		0x5B[7]	0x5B[6]	0x5B[5]	0x5B[4]	0x5B[3]	0x5B[2]	0x5B[1]	0x5B[0]
Default Value		0x54	0	1	0	1	0	1	0

Table 8. Multi DS80PCI800 EEPROM Data⁽¹⁾

EEPROM Address	Address (Hex)	EEPROM Data	Comments
0	00	0x43	CRC_EN = 0, Address Map = 1, >256 bytes = 0, Device Count[3:0] = 3
1	01	0x00	
2	02	0x10	EEPROM Burst Size
3	03	0x00	CRC not used
4	04	0x0B	Device 0 Address Location
5	05	0x00	CRC not used
6	06	0x0B	Device 1 Address Location
7	07	0x00	CRC not used
8	08	0x30	Device 2 Address Location
9	09	0x00	CRC not used
10	0A	0x30	Device 3 Address Location
11	0B	0x00	Begin Device 0, 1 - Address Offset 3
12	0C	0x00	
13	0D	0x04	
14	0E	0x07	
15	0F	0x00	
16	10	0x00	EQ CHB_0 = 0x00
17	11	0xAB	VOD CHB_0 = 1.0 V
18	12	0x00	DEM CHB_0 = 0 (0 dB)
19	13	0x00	EQ CHB_1 = 0x00
20	14	0x0A	VOD CHB_1 = 1.0 V
21	15	0xB0	DEM CHB_1 = 0 (0 dB)
22	16	0x00	
23	17	0x00	EQ CHB_2 = 0x00
24	18	0xAB	VOD CHB_2 = 1.0 V
25	19	0x00	DEM CHB_2 = 0 (0 dB)
26	1A	0x00	EQ CHB_3 = 0x00
27	1B	0x0A	VOD CHB_3 = 1.0 V
28	1C	0xB0	DEM CHB_3 = 0 (0 dB)
29	1D	0x01	
30	1E	0x80	
31	1F	0x01	EQ CHA_0 = 0x00
32	20	0x56	VOD CHA_0 = 1.0 V
33	21	0x00	DEM CHA_0 = 0 (0 dB)
34	22	0x00	EQ CHA_1 = 0x00
35	23	0x15	VOD CHA_1 = 1.0 V
36	24	0x60	DEM CHA_1 = 0 (0 dB)
37	25	0x00	
38	26	0x01	EQ CHA_2 = 0x00
39	27	0x56	VOD CHA_2 = 1.0 V
40	28	0x00	DEM CHA_2 = 0 (0 dB)
41	29	0x00	EQ CHA_3 = 0x00
42	2A	0x15	VOD CHA_3 = 1.0 V
43	2B	0x60	DEM CHA_3 = 0 (0 dB)
44	2C	0x00	

(1) CRC_EN = 0, Address Map = 1, >256 byte = 0, Device Count[3:0] = 3. This example has all 8 channels set to EQ = 0x00 (min boost), VOD = 1.0 V, DEM = 0 (0 dB) and multiple device can point to the same address map.

DS80PCI800

SNLS334G – APRIL 2011 – REVISED JANUARY 2015

www.ti.com

Table 8. Multi DS80PCI800 EEPROM Data⁽¹⁾ (continued)

EEPROM Address	Address (Hex)	EEPROM Data	Comments
45	2D	0x00	
46	2E	0x54	
47	2F	0x54	End Device 0, 1 - Address Offset 39
48	30	0x00	Begin Device 2, 3 - Address Offset 3
49	31	0x00	
50	32	0x04	
51	33	0x07	
52	34	0x00	
53	35	0x00	EQ CHB_0 = 0x00
54	36	0xAB	VOD CHB_0 = 1.0 V
55	37	0x00	DEM CHB_0 = 0 (0 dB)
56	38	0x00	EQ CHB_1 = 0x00
57	39	0x0A	VOD CHB_1 = 1.0 V
58	3A	0xB0	DEM CHB_1 = 0 (0 dB)
59	3B	0x00	
60	3C	0x00	EQ CHB_2 = 0x00
61	3D	0xAB	VOD CHB_2 = 1.0 V
62	3E	0x00	DEM CHB_2 = 0 (0 dB)
63	3F	0x00	EQ CHB_3 = 0x00
64	40	0x0A	VOD CHB_3 = 1.0 V
65	41	0xB0	DEM CHB_3 = 0 (0 dB)
66	42	0x01	
67	43	0x80	
68	44	0x01	EQ CHA_0 = 0x00
69	45	0x56	VOD CHA_0 = 1.0 V
70	46	0x00	DEM CHA_0 = 0 (0 dB)
71	47	0x00	EQ CHA_1 = 0x00
72	48	0x15	VOD CHA_1 = 1.0 V
73	49	0x60	DEM CHA_1 = 0 (0 dB)
74	4A	0x00	
75	4B	0x01	EQ CHA_2 = 0x00
76	4C	0x56	VOD CHA_2 = 1.0 V
77	4D	0x00	DEM CHA_2 = 0 (0 dB)
78	4E	0x00	EQ CHA_3 = 0x00
79	4F	0x15	VOD CHA_3 = 1.0 V
80	50	0x60	DEM CHA_3 = 0 (0 dB)
81	51	0x00	
82	52	0x00	
83	53	0x54	
84	54	0x54	End Device 2, 3 - Address Offset 39

Table 9. SMBus Slave Mode Register Map

Address	Register Name	Bit	Field	Type	Default	EEPROM Bit	Description	
0x00	Device Address Observation	7	Reserved	R/W	0x00		Set bit to 0	
		6:3	Address Bit AD[3:0]	R			Observation of AD[3:0] bit [6]: AD3 [5]: AD2 [4]: AD1 [3]: AD0 See Table 6	
		2	EEPROM Read Done	R			1: Device completed the read from external EEPROM	
		1:0	Reserved	R/W			Reserved	
0x01	PWDN Channels	7:0	PWDN CHx	R/W	0x00	Yes	Power Down per Channel [7]: CH7 – CHA_3 [6]: CH6 – CHA_2 [5]: CH5 – CHA_1 [4]: CH4 – CHA_0 [3]: CH3 – CHB_3 [2]: CH2 – CHB_2 [1]: CH1 – CHB_1 [0]: CH0 – CHB_0 0x00 = all channels enabled 0xFF = all channels disabled Note: override PRSNT pin	
0x02	Override PRSNT Control	7	Override RXDET	R/W	0x00		1 = Override Automatic Rx Detect State Machine Reset	
		6	RXDET Value				1 = Set Rx Detect State Machine Reset 0 = Clear Rx Detect State Machine Reset	
		5:2	Reserved				Yes	Set bits to 0
		1	Reserved					Set bit to 0
		0	Override PRSNT				Yes	1: Block PRSNT pin control 0: Allow PRSNT pin control
0x03	Reserved	7:0	Reserved	R/W	0x00		Set bits to 0	
0x04	Reserved	7:0	Reserved	R/W	0x00	Yes	Set bits to 0	
0x05	Reserved	7:0	Reserved	R/W	0x00		Set bits to 0	
0x06	Slave Register Control	7:5	Reserved	R/W	0x10		Set bits to 0	
		4	Reserved				Yes	Set bit to 1
		3	Register Enable				1 = Enables SMBus Slave Mode Register Control Note: To change VOD, DEM, and EQ of the channels in slave mode, this bit must be set to 1.	
		2:0	Reserved					Set bits to 0
0x07	Digital Reset Control	7	Reserved	R/W	0x01		Set bit to 0	
		6	Reset Registers				Self clearing bit, set to 1 to reset the register to default values.	
		5:0	Reserved				Set bits to 000001'b	

DS80PCI800

SNLS334G – APRIL 2011 – REVISED JANUARY 2015

www.ti.com

Table 9. SMBus Slave Mode Register Map (continued)

Address	Register Name	Bit	Field	Type	Default	EEPROM Bit	Description
0x08	Override Pin Control	7	Reserved	R/W	0x00		Set bit to 0
		6	Override SD_TH			Yes	1: Block SD_TH pin control 0: Allow SD_TH pin control
		5	Reserved			Yes	Set bit to 0
		4	Override IDLE			Yes	1: IDLE control by registers 0: IDLE control by signal detect
		3	Override RXDET			Yes	1: Block RXDET pin control 0: Allow RXDET pin control
		2	Override RATE			Yes	1: Block RATE pin control 0: Allow RATE pin control
		1:0	Reserved				Set bit to 0
0x09	Reserved	7:0	Reserved	R/W	0x00		Set bits to 0
0x0A	Signal Detect Monitor	7:0	SD_TH Status	R	0x00		CH7 - CH0 Internal Signal Detector Indicator [7]: CH7 - CHA_3 [6]: CH6 - CHA_2 [5]: CH5 - CHA_1 [4]: CH4 - CHA_0 [3]: CH3 - CHB_3 [2]: CH2 - CHB_2 [1]: CH1 - CHB_1 [0]: CH0 - CHB_0 0 = Signal detected at input (active data) 1 = Signal not detected at input (idle state) NOTE: These bits only function when RATE pin = FLOAT.
0x0B	Reserved	7	Reserved	R/W	0x00		Set bits to 0
		6:0	Reserved	R/W	0x70	Yes	Set bits to 111 0000'b
0x0C	Reserved	7:0	Reserved	R/W	0x00		Set bits to 0
0x0D	Reserved	7:0	Reserved	R/W	0x00		Set bits to 0
0x0E	CH0 - CHB_0 IDLE, RXDET	7:6	Reserved	R/W	0x00		Set bits to 0
		5	IDLE_AUTO			Yes	1 = Allow IDLE_SEL control in bit 4 0 = Automatic IDLE detect Note: Override IDLE control
		4	IDLE_SEL			Yes	1: Output is MUTED (electrical idle) 0: Output is ON Note: Override IDLE control
		3:2	RXDET			Yes	00: Input is hi-Z impedance 01: Auto RX-Detect, outputs test every 12 ms for 600 ms (50 times) then stops; termination is hi-Z until detection; once detected input termination is 50 Ω 10: Auto RX-Detect, outputs test every 12 ms until detection occurs; termination is hi-Z until detection; once detected input termination is 50 Ω 11: Input is 50 Ω Note: Override RXDET pin
		1:0	Reserved				Set bits to 0
0x0F	CH0 - CHB_0 EQ	7:0	EQ Control	R/W	0x2F	Yes	INB_0 EQ Control - total of 256 levels See Table 2

Table 9. SMBus Slave Mode Register Map (continued)

Address	Register Name	Bit	Field	Type	Default	EEPROM Bit	Description
0x10	CH0 - CHB_0 VOD	7	Short Circuit Protection	R/W	0xAD	Yes	1: Enable the short circuit protection 0: Disable the short circuit protection
		6	RATE_SEL			Yes	1: Gen 1/2 0: Gen 3 Note: Override the RATE pin
		5:3	Reserved			Yes	Set bits to default value - 101
		2:0	VOD Control			Yes	OUTB_0 VOD Control 000: 0.7 V 001: 0.8 V 010: 0.9 V 011: 1.0 V 100: 1.1 V 101: 1.2 V (default) 110: 1.3 V 111: 1.4 V
0x11	CH0 - CHB_0 DEM	7	RXDET STATUS	R	0x02		Observation bit for RXDET CH0 - CHB_0 1: RX = detected 0: RX = not detected
		6:5	RATE_DET STATUS	R			Observation bit for RATE_DET CH0 - CHB_0 00: GEN1 (2.5G) 01: GEN2 (5G) 11: GEN3 (8G)
		4:3	Reserved	R/W			Set bits to 0
		2:0	DEM Control	R/W		Yes	OUTB_0 DEM Control 000: 0 dB 001: -1.5 dB 010: -3.5 dB (default) 011: -5 dB 100: -6 dB 101: -8 dB 110: -9 dB 111: -12 dB
0x12	CH0 - CHB_0 IDLE Threshold	7	Reserved	R/W	0x00	Yes	Set bit to 0
		6:4	Reserved				Set bits to 0
		3:2	IDLE tha			Yes	Assert threshold 00 = 180 mVp-p (default) 01 = 160 mVp-p 10 = 210 mVp-p 11 = 190 mVp-p Note: Override the SD_TH pin
		1:0	IDLE thd			Yes	Deassert threshold 00 = 110 mVp-p (default) 01 = 100 mVp-p 10 = 150 mVp-p 11 = 130 mVp-p Note: Override the SD_TH pin
0x13	Reserved	7:0	Reserved	R/W	0x00		Set bits to 0
0x14	Reserved	7:0	Reserved	R/W	0x00		Set bits to 0

DS80PCI800

SNLS334G – APRIL 2011 – REVISED JANUARY 2015

www.ti.com

Table 9. SMBus Slave Mode Register Map (continued)

Address	Register Name	Bit	Field	Type	Default	EEPROM Bit	Description
0x15	CH1 - CHB_1 IDLE, RXDET	7:6	Reserved	R/W	0x00		Set bits to 0
		5	IDLE_AUTO			Yes	1 = Allow IDLE_SEL control in bit 4 0 = Automatic IDLE detect Note: Override IDLE control
		4	IDLE_SEL			Yes	1: Output is MUTED (electrical idle) 0: Output is ON Note: Override IDLE control
		3:2	RXDET			Yes	00: Input is hi-Z impedance 01: Auto RX-Detect, outputs test every 12 ms for 600 ms (50 times) then stops; termination is hi-Z until detection; once detected input termination is 50 Ω 10: Auto RX-Detect, outputs test every 12 ms until detection occurs; termination is hi-Z until detection; once detected input termination is 50 Ω 11: Input is 50 Ω Note: Override RXDET pin
		1:0	Reserved				Set bits to 0.
0x16	CH1 - CHB_1 EQ	7:0	EQ Control	R/W	0x2F	Yes	INB_1 EQ Control - total of 256 levels. See Table 2
0x17	CH1 - CHB_1 VOD	7	Short Circuit Protection	R/W	0xAD	Yes	1: Enable the short circuit protection 0: Disable the short circuit protection
		6	RATE_SEL			Yes	1: Gen 1/2 0: Gen 3 Note: Override the RATE pin
		5:3	Reserved			Yes	Set bits to default value - 101
		2:0	VOD Control			Yes	OUTB_1 VOD Control 000: 0.7 V 001: 0.8 V 010: 0.9 V 011: 1.0 V 100: 1.1 V 101: 1.2 V (default) 110: 1.3 V 111: 1.4 V
0x18	CH1 - CHB_1 DEM	7	RXDET STATUS	R	0x02		Observation bit for RXDET CH1 - CHB_1 1: RX = detected 0: RX = not detected
		6:5	RATE_DET STATUS	R		Observation bit for RATE_DET CH1 - CHB_1 00: GEN1 (2.5G) 01: GEN2 (5G) 11: GEN3 (8G)	
		4:3	Reserved	R/W		Set bits to 0	
		2:0	DEM Control	R/W		Yes	OUTB_1 DEM Control 000: 0 dB 001: -1.5 dB 010: -3.5 dB (default) 011: -5 dB 100: -6 dB 101: -8 dB 110: -9 dB 111: -12 dB

Table 9. SMBus Slave Mode Register Map (continued)

Address	Register Name	Bit	Field	Type	Default	EEPROM Bit	Description
0x19	CH1 - CHB_1 IDLE Threshold	7	Reserved	R/W	0x00	Yes	Set bit to 0.
		6:4	Reserved				Set bits to 0.
		3:2	IDLE tha			Yes	Assert threshold 00 = 180 mVp-p (default) 01 = 160 mVp-p 10 = 210 mVp-p 11 = 190 mVp-p Note: Override the SD_TH pin
		1:0	IDLE thd			Yes	Deassert threshold 00 = 110 mVp-p (default) 01 = 100 mVp-p 10 = 150 mVp-p 11 = 130 mVp-p Note: Override the SD_TH pin
0x1A	Reserved	7:0	Reserved	R/W	0x00		Set bits to 0
0x1B	Reserved	7:0	Reserved	R/W	0x00		Set bits to 0
0x1C	CH2 - CHB_2 IDLE, RXDET	7:6	Reserved	R/W	0x00		Set bits to 0
		5	IDLE_AUTO			Yes	1 = Allow IDLE_SEL control in bit 4 0 = Automatic IDLE detect Note: Override IDLE control
		4	IDLE_SEL			Yes	1: Output is MUTED (electrical idle) 0: Output is ON Note: Override IDLE control
		3:2	RXDET			Yes	00: Input is hi-Z impedance 01: Auto RX-Detect, outputs test every 12 ms for 600 ms (50 times) then stops; termination is hi-Z until detection; once detected input termination is 50 Ω 10: Auto RX-Detect, outputs test every 12 ms until detection occurs; termination is hi-Z until detection; once detected input termination is 50 Ω 11: Input is 50 Ω Note: Override RXDET pin
		1:0	Reserved				Set bits to 0
0x1D	CH2 - CHB_2 EQ	7:0	EQ Control	R/W	0x2F	Yes	INB_2 EQ Control - total of 256 levels. See Table 2
0x1E	CH2 - CHB_2 VOD	7	Short Circuit Protection	R/W	0xAD	Yes	1: Enable the short circuit protection 0: Disable the short circuit protection
		6	RATE_SEL			Yes	1: Gen 1/2 0: Gen 3 Note: Override the RATE pin
		5:3	Reserved			Yes	Set bits to default value - 101
		2:0	VOD Control			Yes	OUTB_2 VOD Control 000: 0.7 V 001: 0.8 V 010: 0.9 V 011: 1.0 V 100: 1.1 V 101: 1.2 V (default) 110: 1.3 V 111: 1.4 V

DS80PCI800

SNLS334G – APRIL 2011 – REVISED JANUARY 2015

www.ti.com

Table 9. SMBus Slave Mode Register Map (continued)

Address	Register Name	Bit	Field	Type	Default	EEPROM Bit	Description
0x1F	CH2 - CHB_2 DEM	7	RXDET STATUS	R	0x02		Observation bit for RXDET CH2 - CHB_2 1: RX = detected 0: RX = not detected
		6:5	RATE_DET STATUS	R			Observation bit for RATE_DET CH2 - CHB_2 00: GEN1 (2.5G) 01: GEN2 (5G) 11: GEN3 (8G)
		4:3	Reserved	R/W			Set bits to 0.
		2:0	DEM Control	R/W		Yes	OUTB_2 DEM Control 000: 0 dB 001: -1.5 dB 010: -3.5 dB (default) 011: -5 dB 100: -6 dB 101: -8 dB 110: -9 dB 111: -12 dB
0x20	CH2 - CHB_2 IDLE Threshold	7	Reserved	R/W	0x00	Yes	Set bit to 0
		6:4	Reserved				Set bits to 0
		3:2	IDLE tha			Yes	Assert threshold 00 = 180 mVp-p (default) 01 = 160 mVp-p 10 = 210 mVp-p 11 = 190 mVp-p Note: Override the SD_TH pin. Set bits to 0
		1:0	IDLE thd			Yes	Deassert threshold 00 = 110 mVp-p (default) 01 = 100 mVp-p 10 = 150 mVp-p 11 = 130 mVp-p Note: Override the SD_TH pin
0x21	Reserved	7:0	Reserved	R/W	0x00		Set bits to 0
0x22	Reserved	7:0	Reserved	R/W	0x00		Set bits to 0
0x23	CH3 - CHB_3 IDLE, RXDET	7:6	Reserved	R/W	0x00		Set bits to 0
		5	IDLE_AUTO			Yes	1 = Allow IDLE_SEL control in bit 4 0 = Automatic IDLE detect Note: Override IDLE control
		4	IDLE_SEL			Yes	1: Output is MUTED (electrical idle) 0: Output is ON Note: Override IDLE control.
		3:2	RXDET			Yes	00: Input is hi-Z impedance 01: Auto RX-Detect, outputs test every 12 ms for 600 ms (50 times) then stops; termination is hi-Z until detection; once detected input termination is 50 Ω 10: Auto RX-Detect, outputs test every 12 ms until detection occurs; termination is hi-Z until detection; once detected input termination is 50 Ω 11: Input is 50 Ω Note: Override RXDET pin
		1:0	Reserved				Set bits to 0
0x24	CH3 - CHB_3 EQ	7:0	EQ Control	R/W	0x2F	Yes	INB_3 EQ Control - total of 256 levels. See Table 2

Table 9. SMBus Slave Mode Register Map (continued)

Address	Register Name	Bit	Field	Type	Default	EEPROM Bit	Description
0x25	CH3 - CHB_3 VOD	7	Short Circuit Protection	R/W	0xAD	Yes	1: Enable the short circuit protection 0: Disable the short circuit protection
		6	RATE_SEL			Yes	1: Gen 1/2 0: Gen 3 Note: Override the RATE pin
		5:3	Reserved			Yes	Set bits to default value - 101
		2:0	VOD Control			Yes	OUTB_3 VOD Control 000: 0.7 V 001: 0.8 V 010: 0.9 V 011: 1.0 V 100: 1.1 V 101: 1.2 V (default) 110: 1.3 V 111: 1.4 V
0x26	CH3 - CHB_3 DEM	7	RXDET STATUS	R	0x02		Observation bit for RXDET CH3 - CHB_3 1: RX = detected 0: RX = not detected
		6:5	RATE_DET STATUS	R			Observation bit for RATE_DET CH3 - CHB_3 00: GEN1 (2.5G) 01: GEN2 (5G) 11: GEN3 (8G)
		4:3	Reserved	R/W			Set bits to 0
		2:0	DEM Control	R/W		Yes	OUTB_3 DEM Control 000: 0 dB 001: -1.5 dB 010: -3.5 dB (default) 011: -5 dB 100: -6 dB 101: -8 dB 110: -9 dB 111: -12 dB
0x27	CH3 - CHB_3 IDLE Threshold	7	Reserved	R/W	0x00	Yes	Set bit to 0
		6:4	Reserved				Set bits to 0
		3:2	IDLE tha			Yes	Assert threshold 00 = 180 mVp-p (default) 01 = 160 mVp-p 10 = 210 mVp-p 11 = 190 mVp-p Note: Override the SD_TH pin
		1:0	IDLE thd			Yes	Deassert threshold 00 = 110 mVp-p (default) 01 = 100 mVp-p 10 = 150 mVp-p 11 = 130 mVp-p Note: Override the SD_TH pin
0x28	Signal Detect Status Control	7	Reserved	R/W	0x0C		Set bit to 0
		6	Reserved			Yes	Set bit to 0
		5:4	High SD_TH Status			Yes	Enable Higher Range of Signal Detect Status Thresholds [5]: CH0 - CH3 [4]: CH4 - CH7
		3:2	Fast Signal Detect Status			Yes	Enable Fast Signal Detect Status [3]: CH0 - CH3 [2]: CH4 - CH7 Note: In Fast Signal Detect, assert/deassert response occurs after approximately 3-4 ns
		1:0	Reduced SD Status Gain			Yes	Enable Reduced Signal Detect Status Gain [1]: CH0 - CH3 [0]: CH4 - CH7

DS80PCI800

SNLS334G – APRIL 2011 – REVISED JANUARY 2015

www.ti.com

Table 9. SMBus Slave Mode Register Map (continued)

Address	Register Name	Bit	Field	Type	Default	EEPROM Bit	Description
0x29	Reserved	7:0	Reserved	R/W	0x00		Set bits to 0
0x2A	Reserved	7:0	Reserved	R/W	0x00		Set bits to 0
0x2B	CH4 - CHA_0 IDLE, RXDET	7:6	Reserved	R/W	0x00		Set bits to 0
		5	IDLE_AUTO			Yes	1 = Allow IDLE_SEL control in bit 4 0 = Automatic IDLE detect Note: Override IDLE control
		4	IDLE_SEL			Yes	1: Output is MUTED (electrical idle) 0: Output is ON Note: Override IDLE control
		3:2	RXDET			Yes	00: Input is hi-Z impedance 01: Auto RX-Detect, outputs test every 12 ms for 600 ms (50 times) then stops; termination is hi-Z until detection; once detected input termination is 50 Ω 10: Auto RX-Detect, outputs test every 12 ms until detection occurs; termination is hi-Z until detection; once detected input termination is 50 Ω 11: Input is 50 Ω Note: Override RXDET pin
		1:0	Reserved				Set bits to 0
0x2C	CH4 - CHA_0 EQ	7:0	EQ Control	R/W	0x2F	Yes	INA_0 EQ Control - total of 256 levels See Table 2
0x2D	CH4 - CHA_0 VOD	7	Short Circuit Protection	R/W	0xAD	Yes	1: Enable the short circuit protection 0: Disable the short circuit protection
		6	RATE_SEL			Yes	1: Gen 1/2 0: Gen 3 Note: Override the RATE pin
		5:3	Reserved			Yes	Set bits to default value - 101
		2:0	VOD Control			Yes	OUTA_0 VOD Control 000: 0.7 V 001: 0.8 V 010: 0.9 V 011: 1.0 V 100: 1.1 V 101: 1.2 V (default) 110: 1.3 V 111: 1.4 V
0x2E	CH4 - CHA_0 DEM	7	RXDET STATUS	R	0x02		Observation bit for RXDET CH4 - CHA_0 1: RX = detected 0: RX = not detected
		6:5	RATE_DET STATUS	R			Observation bit for RATE_DET CH4 - CHA_0 00: GEN1 (2.5G) 01: GEN2 (5G) 11: GEN3 (8G)
		4:3	Reserved	R/W			Set bits to 0
		2:0	DEM Control	R/W		Yes	OUTA_0 DEM Control 000: 0 dB 001: -1.5 dB 010: -3.5 dB (default) 011: -5 dB 100: -6 dB 101: -8 dB 110: -9 dB 111: -12 dB

Table 9. SMBus Slave Mode Register Map (continued)

Address	Register Name	Bit	Field	Type	Default	EEPROM Bit	Description
0x2F	CH4 - CHA_0 IDLE Threshold	7	Reserved	R/W	0x00	Yes	Set bit to 0
		6:4	Reserved				Set bits to 0
		3:2	IDLE tha			Yes	Assert threshold 00 = 180 mVp-p (default) 01 = 160 mVp-p 10 = 210 mVp-p 11 = 190 mVp-p Note: Override the SD_TH pin
		1:0	IDLE thd			Yes	Deassert threshold 00 = 110 mVp-p (default) 01 = 100 mVp-p 10 = 150 mVp-p 11 = 130 mVp-p Note: Override the SD_TH pin
0x30	Reserved	7:0	Reserved	R/W	0x00		Set bits to 0
0x31	Reserved	7:0	Reserved	R/W	0x00		Set bits to 0
0x32	CH5 - CHA_1 IDLE, RXDET	7:6	Reserved	R/W	0x00		Set bits to 0
		5	IDLE_AUTO			Yes	1 = Allow IDLE_SEL control in bit 4 0 = Automatic IDLE detect Note: Override IDLE control
		4	IDLE_SEL			Yes	1: Output is MUTED (electrical idle) 0: Output is ON Note: Override IDLE control
		3:2	RXDET			Yes	00: Input is hi-Z impedance 01: Auto RX-Detect, outputs test every 12 ms for 600 ms (50 times) then stops; termination is hi-Z until detection; once detected input termination is 50 Ω 10: Auto RX-Detect, outputs test every 12 ms until detection occurs; termination is hi-Z until detection; once detected input termination is 50 Ω 11: Input is 50 Ω Note: override RXDET pin
		1:0	Reserved				Set bits to 0
0x33	CH5 - CHA_1 EQ	7:0	EQ Control	R/W	0x2F	Yes	INA_1 EQ Control - total of 256 levels See Table 2
0x34	CH5 - CHA_1 VOD	7	Short Circuit Protection	R/W	0xAD	Yes	1: Enable the short circuit protection 0: Disable the short circuit protection
		6	RATE_SEL			Yes	1: Gen 1/2 0: Gen 3 Note: Override the RATE pin
		5:3	Reserved			Yes	Set bits to default value - 101
		2:0	VOD Control			Yes	QUTA_1 VOD Control 000: 0.7 V 001: 0.8 V 010: 0.9 V 011: 1.0 V 100: 1.1 V 101: 1.2 V (default) 110: 1.3 V 111: 1.4 V

DS80PCI800

SNLS334G – APRIL 2011 – REVISED JANUARY 2015

www.ti.com

Table 9. SMBus Slave Mode Register Map (continued)

Address	Register Name	Bit	Field	Type	Default	EEPROM Bit	Description
0x35	CH5 - CHA_1 DEM	7	RXDET STATUS	R	0x02		Observation bit for RXDET CH5 - CHA_1 1: RX = detected 0: RX = not detected
		6:5	RATE_DET STATUS	R			Observation bit for RATE_DET CH5 - CHA_1 00: GEN1 (2.5G) 01: GEN2 (5G) 11: GEN3 (8G)
		4:3	Reserved	R/W			Set bits to 0
		2:0	DEM Control	R/W		Yes	OUTA_1 DEM Control 000: 0 dB 001: -1.5 dB 010: -3.5 dB (default) 011: -5 dB 100: -6 dB 101: -8 dB 110: -9 dB 111: -12 dB
0x36	CH5 - CHA_1 IDLE Threshold	7	Reserved	R/W	0x00	Yes	Set bit to 0
		6:4	Reserved				Set bits to 0
		3:2	IDLE tha			Yes	Assert threshold 00 = 180 mVp-p (default) 01 = 160 mVp-p 10 = 210 mVp-p 11 = 190 mVp-p Note: Override the SD_TH pin
		1:0	IDLE thd			Yes	Deassert threshold 00 = 110 mVp-p (default) 01 = 100 mVp-p 10 = 150 mVp-p 11 = 130 mVp-p Note: Override the SD_TH pin
0x37	Reserved	7:0	Reserved	R/W	0x00		Set bits to 0
0x38	Reserved	7:0	Reserved	R/W	0x00		Set bits to 0
0x39	CH6 - CHA_2 IDLE, RXDET	7:6	Reserved	R/W	0x00		Set bits to 0
		5	IDLE_AUTO			Yes	1 = Allow IDLE_SEL control in bit 4 0 = Automatic IDLE detect Note: Override IDLE control
		4	IDLE_SEL			Yes	1: Output is MUTED (electrical idle) 0: Output is ON Note: Override IDLE control
		3:2	RXDET			Yes	00: Input is hi-Z impedance 01: Auto RX-Detect, outputs test every 12 ms for 600 ms (50 times) then stops; termination is hi-Z until detection; once detected input termination is 50 Ω 10: Auto RX-Detect, outputs test every 12 ms until detection occurs; termination is hi-Z until detection; once detected input termination is 50 Ω 11: Input is 50 Ω Note: Override RXDET pin
		1:0	Reserved				Set bits to 0
0x3A	CH6 - CHA_2 EQ	7:0	EQ Control	R/W	0x2F	Yes	INA_2 EQ Control - total of 256 levels See Table 2

Table 9. SMBus Slave Mode Register Map (continued)

Address	Register Name	Bit	Field	Type	Default	EEPROM Bit	Description
0x3B	CH6 - CHA_2 VOD	7	Short Circuit Protection	R/W	0xAD	Yes	1: Enable the short circuit protection 0: Disable the short circuit protection
		6	RATE_SEL			Yes	1: Gen 1/2 0: Gen 3 Note: Override the RATE pin
		5:3	Reserved			Yes	Set bits to default value - 101
		2:0	VOD Control			Yes	OUTA_2 VOD Control 000: 0.7 V 001: 0.8 V 010: 0.9 V 011: 1.0 V 100: 1.1 V 101: 1.2 V (default) 110: 1.3 V 111: 1.4 V
0x3C	CH6 - CHA_2 DEM	7	RXDET STATUS	R	0x02		Observation bit for RXDET CH6 - CHA_2 1: RX = detected 0: RX = not detected
		6:5	RATE_DET STATUS	R			Observation bit for RATE_DET CH6 - CHA_2 00: GEN1 (2.5G) 01: GEN2 (5G) 11: GEN3 (8G)
		4:3	Reserved	R/W			Set bits to 0
		2:0	DEM Control	R/W		Yes	OUTA_2 DEM Control 000: 0 dB 001: -1.5 dB 010: -3.5 dB (default) 011: -5 dB 100: -6 dB 101: -8 dB 110: -9 dB 111: -12 dB
0x3D	CH6 - CHA_2 IDLE Threshold	7	Reserved	R/W	0x00	Yes	Set bit to 0
		6:4	Reserved				Set bits to 0
		3:2	IDLE tha			Yes	Assert threshold 00 = 180 mVp-p (default) 01 = 160 mVp-p 10 = 210 mVp-p 11 = 190 mVp-p Note: Override the SD_TH pin
		1:0	IDLE thd			Yes	Deassert threshold 00 = 110 mVp-p (default) 01 = 100 mVp-p 10 = 150 mVp-p 11 = 130 mVp-p Note: Override the SD_TH pin
0x3E	Reserved	7:0	Reserved	R/W	0x00		Set bits to 0
0x3F	Reserved	7:0	Reserved	R/W	0x00		Set bits to 0

DS80PCI800

SNLS334G – APRIL 2011 – REVISED JANUARY 2015

www.ti.com

Table 9. SMBus Slave Mode Register Map (continued)

Address	Register Name	Bit	Field	Type	Default	EEPROM Bit	Description
0x40	CH7 - CHA_3 IDLE, RXDET	7:6	Reserved	R/W	0x00		Set bits to 0
		5	IDLE_AUTO			Yes	1 = Allow IDLE_SEL control in bit 4 0 = Automatic IDLE detect Note: Override IDLE control
		4	IDLE_SEL			Yes	1: Output is MUTED (electrical idle) 0: Output is ON Note: Override IDLE control
		3:2	RXDET			Yes	00: Input is hi-Z impedance 01: Auto RX-Detect, outputs test every 12 ms for 600 ms (50 times) then stops; termination is hi-Z until detection; once detected input termination is 50 Ω 10: Auto RX-Detect, outputs test every 12 ms until detection occurs; termination is hi-Z until detection; once detected input termination is 50 Ω 11: Input is 50 Ω Note: Override RXDET pin
		1:0	Reserved				Set bits to 0
0x41	CH7 - CHA_3 EQ	7:0	EQ Control	R/W	0x2F	Yes	INA_3 EQ Control - total of 256 levels See Table 2
0x42	CH7 - CHA_3 VOD	7	Short Circuit Protection	R/W	0xAD	Yes	1: Enable the short circuit protection 0: Disable the short circuit protection
		6	RATE_SEL			Yes	1: Gen 1/2 0: Gen 3 Note: Override the RATE pin
		5:3	Reserved			Yes	Set bits to default value - 101
		2:0	VOD Control			Yes	OUTA_3 VOD Control 000: 0.7 V 001: 0.8 V 010: 0.9 V 011: 1.0 V 100: 1.1 V 101: 1.2 V (default) 110: 1.3 V 111: 1.4 V
0x43	CH7 - CHA_3 DEM	7	RXDET STATUS	R	0x02		Observation bit for RXDET CH7 - CHA_3 1: RX = detected 0: RX = not detected
		6:5	RATE_DET STATUS	R		Observation bit for RATE_DET CH7 - CHA_3 00: GEN1 (2.5G) 01: GEN2 (5G) 11: GEN3 (8G)	
		4:3	Reserved	R/W		Set bits to 0	
		2:0	DEM Control	R/W		Yes	OUTA_3 DEM Control 000: 0 dB 001: -1.5 dB 010: -3.5 dB (default) 011: -5 dB 100: -6 dB 101: -8 dB 110: -9 dB 111: -12 dB

Table 9. SMBus Slave Mode Register Map (continued)

Address	Register Name	Bit	Field	Type	Default	EEPROM Bit	Description
0x44	CH7 - CHA_3 IDLE Threshold	7	Reserved	R/W	0x00	Yes	Set bit to 0
		6:4	Reserved				Set bits to 0
		3:2	IDLE tha			Yes	Assert threshold 00 = 180 mVp-p (default) 01 = 160 mVp-p 10 = 210 mVp-p 11 = 190 mVp-p Note: Override the SD_TH pin
		1:0	IDLE thd			Yes	Deassert threshold 00 = 110 mVp-p (default) 01 = 100 mVp-p 10 = 150 mVp-p 11 = 130 mVp-p Note: Override the SD_TH pin
0x45	Reserved	7:0	Reserved	R/W	0x00		Set bits to 0
0x46	Reserved	7:0	Reserved	R/W	0x38		Set bits to 0x38
0x47	Reserved	7:4	Reserved	R/W	0x00		Set bits to 0
		3:0	Reserved	R/W		Yes	Set bits to 0
0x48	Reserved	7:6	Reserved	R/W	0x05	Yes	Set bits to 0
		5:0	Reserved	R/W			Set bits to 00 0101'b
0x49	Reserved	7:0	Reserved	R/W	0x00		Set bits to 0
0x4A	Reserved	7:0	Reserved	R/W	0x00		Set bits to 0
0x4B	Reserved	7:0	Reserved	R/W	0x00		Set bits to 0
0x4C	Reserved	7:3	Reserved	R/W	0x00	Yes	Set bits to 0
		2:1	Reserved	R/W			Set bits to 0
		0	Reserved	R/W		Yes	Set bits to 0
0x4D	Reserved	7:0	Reserved	R/W	0x00		Set bits to 0
0x4E	Reserved	7:0	Reserved	R/W	0x00		Set bits to 0
0x4F	Reserved	7:0	Reserved	R/W	0x00		Set bits to 0
0x50	Reserved	7:0	Reserved	R/W	0x00		Set bits to 0
0x51	Device ID	7:5	VERSION	R	0x45		010'b
		4:0	ID				00101'b
0x52	Reserved	7:0	Reserved	R/W	0x00		Set bits to 0
0x53	Reserved	7:0	Reserved	R/W	0x00		Set bits to 0
0x54	Reserved	7:0	Reserved	R/W	0x00		Set bits to 0
0x55	Reserved	7:0	Reserved	R/W	0x00		Set bits to 0
0x56	Reserved	7:0	Reserved	R/W	0x10		Set bits to 0x10
0x57	Reserved	7:0	Reserved	R/W	0x64		Set bits to 0x64
0x58	Reserved	7:0	Reserved	R/W	0x21		Set bits to 0x21
0x59	Reserved	7:1	Reserved	R/W	0x00		Set bits to 0
		0	Reserved			Yes	Set bit to 0
0x5A	Reserved	7:0	Reserved	R/W	0x54	Yes	Set bits to 0x54
0x5B	Reserved	7:0	Reserved	R/W	0x54	Yes	Set bits to 0x54
0x5C	Reserved	7:0	Reserved	R/W	0x00		Set bits to 0
0x5D	Reserved	7:0	Reserved	R/W	0x00		Set bits to 0
0x5E	Reserved	7:0	Reserved	R/W	0x00		Set bits to 0
0x5F	Reserved	7:0	Reserved	R/W	0x00		Set bits to 0
0x60	Reserved	7:0	Reserved	R/W	0x00		Set bits to 0
0x61	Reserved	7:0	Reserved	R/W	0x00		Set bits to 0

DS80PCI800

SNLS334G – APRIL 2011 – REVISED JANUARY 2015

www.ti.com

9 Application and Implementation**NOTE**

Information in the following applications sections is not part of the TI component specification, and TI does not warrant its accuracy or completeness. TI's customers are responsible for determining suitability of components for their purposes. Customers should validate and test their design implementation to confirm system functionality.

9.1 Application Information**9.1.1 DS80PCI800 versus DS80PCI810**

The DS80PCI800 and DS80PCI810 are pin compatible, and both can be used for PCIe Gen-1, 2, and 3 applications. The DS80PCI800 is ideal for closed PCIe systems where significant insertion losses (> 35 dB at 4 GHz) are expected in the signal path. A closed system is defined as a PCIe environment with a limited number of possible Host-to-Endpoint combinations. The DS80PCI800 can extend the reach of a PCIe system by up to 36 dB beyond the max allowable PCIe channel loss, whereas the DS80PCI810 can extend the system range up to 10 dB while offering a larger dynamic range on output linearity. Due to the larger CTLE gain, the DS80PCI800 is able to compensate insertion loss over longer transmission lines before the repeater. In addition, the DS80PCI800 is able to produce de-emphasis levels up to -12 dB to support significant trace losses after the repeater (-15 dB at 4 GHz).

9.1.2 Signal Integrity in PCIe Applications

In PCIe Gen-3 applications, the specification requires Rx-Tx link training to establish and optimize signal conditioning settings at 8 Gbps. In link training, the Rx partner requests a series of FIR - preshoot and de-emphasis coefficients (10 Presets) from the Tx partner. The Rx partner includes 7-levels (6 dB to 12 dB) of CTLE followed by a single tap DFE. The link training would pre-condition the signal with an equalized link between the root-complex and endpoint. Note that there is no link training in PCIe Gen-1 (2.5 Gbps) or PCIe Gen-2 (5.0 Gbps) applications. The DS80PCI800 is placed in between the Tx and Rx. It would help extend the PCB trace reach distance by boosting the attenuated signals with its equalization, so that the signal can be more easily recovered by the downstream Rx. In Gen 3 mode, DS80PCI800 transmit outputs are designed to pass the Tx Preset signaling onto the Rx for the PCIe Gen 3 link to train and optimize the equalization settings. The suggested setting for the DS80PCI800 are EQ = 0x00, VOD = 1.2 Vp-p and DEM = 0 dB. Additional adjustments to increase the EQ or DEM setting should be performed to optimize the eye opening in the Rx partner. See the tables below for Pin Mode and SMBus Mode configurations.

Table 10. Suggested Device Settings in Pin Mode

Channel	Pin Mode Settings
EQx[1:0]	0, 0 (Level 1)
DEMx[1:0]	Float, R (Level 10)

Table 11. Suggested Device Settings in SMBus Slave Mode

Register	Write Value	Comments
0x06	0x18	Enables SMBus Slave Mode Register Control
0x0F	0x00	Set CHB_0 EQ to 0x00.
0x10	0xAD	Set CHB_0 VOD to 101'b (1.2 Vp-p).
0x11	0x00	Set CHB_0 DEM to 000'b (0 dB).
0x16	0x00	Set CHB_1 EQ to 0x00.
0x17	0xAD	Set CHB_1 VOD to 101'b (1.2 Vp-p).
0x18	0x00	Set CHB_1 DEM to 000'b (0 dB).
0x1D	0x00	Set CHB_2 EQ to 0x00.
0x1E	0xAD	Set CHB_2 VOD to 101'b (1.2 Vp-p).
0x1F	0x00	Set CHB_2 DEM to 000'b (0 dB).
0x24	0x00	Set CHB_3 EQ to 0x00.

Table 11. Suggested Device Settings in SMBus Slave Mode (continued)

Register	Write Value	Comments
0x25	0xAD	Set CHB_3 VOD to 101'b (1.2 Vp-p).
0x26	0x00	Set CHB_3 DEM to 000'b (0 dB).
0x2C	0x00	Set CHA_0 EQ to 0x00.
0x2D	0xAD	Set CHA_0 VOD to 101'b (1.2 Vp-p).
0x2E	0x00	Set CHA_0 DEM to 000'b (0 dB).
0x33	0x00	Set CHA_1 EQ to 0x00.
0x34	0xAD	Set CHA_1 VOD to 101'b (1.2 Vp-p).
0x35	0x00	Set CHA_1 DEM to 000'b (0 dB).
0x3A	0x00	Set CHA_2 EQ to 0x00.
0x3B	0xAD	Set CHA_2 VOD to 101'b (1.2 Vp-p).
0x3C	0x00	Set CHA_2 DEM to 000'b (0 dB).
0x41	0x00	Set CHA_3 EQ to 0x00.
0x42	0xAD	Set CHA_3 VOD to 101'b (1.2 Vp-p).
0x43	0x00	Set CHA_3 DEM to 000'b (0 dB).

9.2 Typical Application

The DS80PCI800 extends PCB trace and cable reach in PCIe Gen1, 2 and 3 applications by applying equalization to compensate for the insertion loss of the trace or cable. In Gen 3 mode, the device aids specifically in the equalization link training to improve the margin and overall eye inside the Rx. The DS80PCI800 can be used on the motherboard, mid plane (riser card), end-point target cards, and active cable assemblies. The capability of the DS80PCI800 performance is shown in the following two test setup connections.

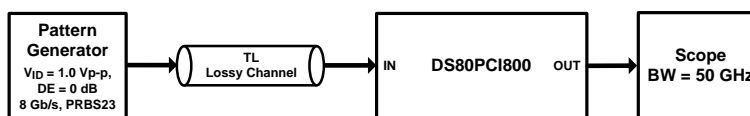
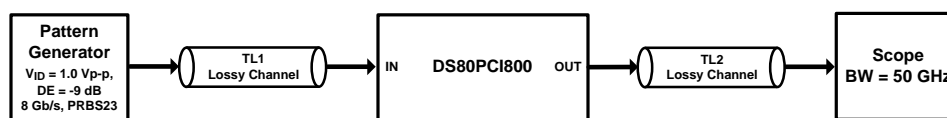
Figure 8. Test Setup 1 Connections Diagram

Figure 9. Test Setup 2 Connections Diagram

9.2.1 Design Requirements

As with any high speed design, there are many factors which influence the overall performance. The following list indicates critical areas for consideration during design.

- Use 100 Ω impedance traces. Length matching on the P and N traces should be done on the single-end segments of the differential pair.
- Use uniform trace width and trace spacing for differential pairs.
- Place AC-coupling capacitors near to the receiver end of each channel segment to minimize reflections.
- For Gen3, AC-coupling capacitors of 220 nF are recommended, maximum body size is 0402, and add cutout void on GND plane below the landing pad of the capacitor to reduce parasitic capacitance to GND.
- Back-drill connector vias and signal vias to minimize stub length.
- Use Reference plane vias to ensure a low inductance path for the return current.

DS80PCI800

SNLS334G – APRIL 2011 – REVISED JANUARY 2015

www.ti.com

Typical Application (continued)**9.2.2 Detailed Design Procedure**

The DS80PCI800 should be placed at an offset location and close to the Rx with respect to the overall channel attenuation. The suggested settings are recommended as a starting point for most applications. Once these settings are configured, additional adjustments of the DS80PCI800 EQ or DE may be required to optimize the repeater performance. The CTLE and DFE coefficient in the Rx can also be adjusted to further improve the eye opening.

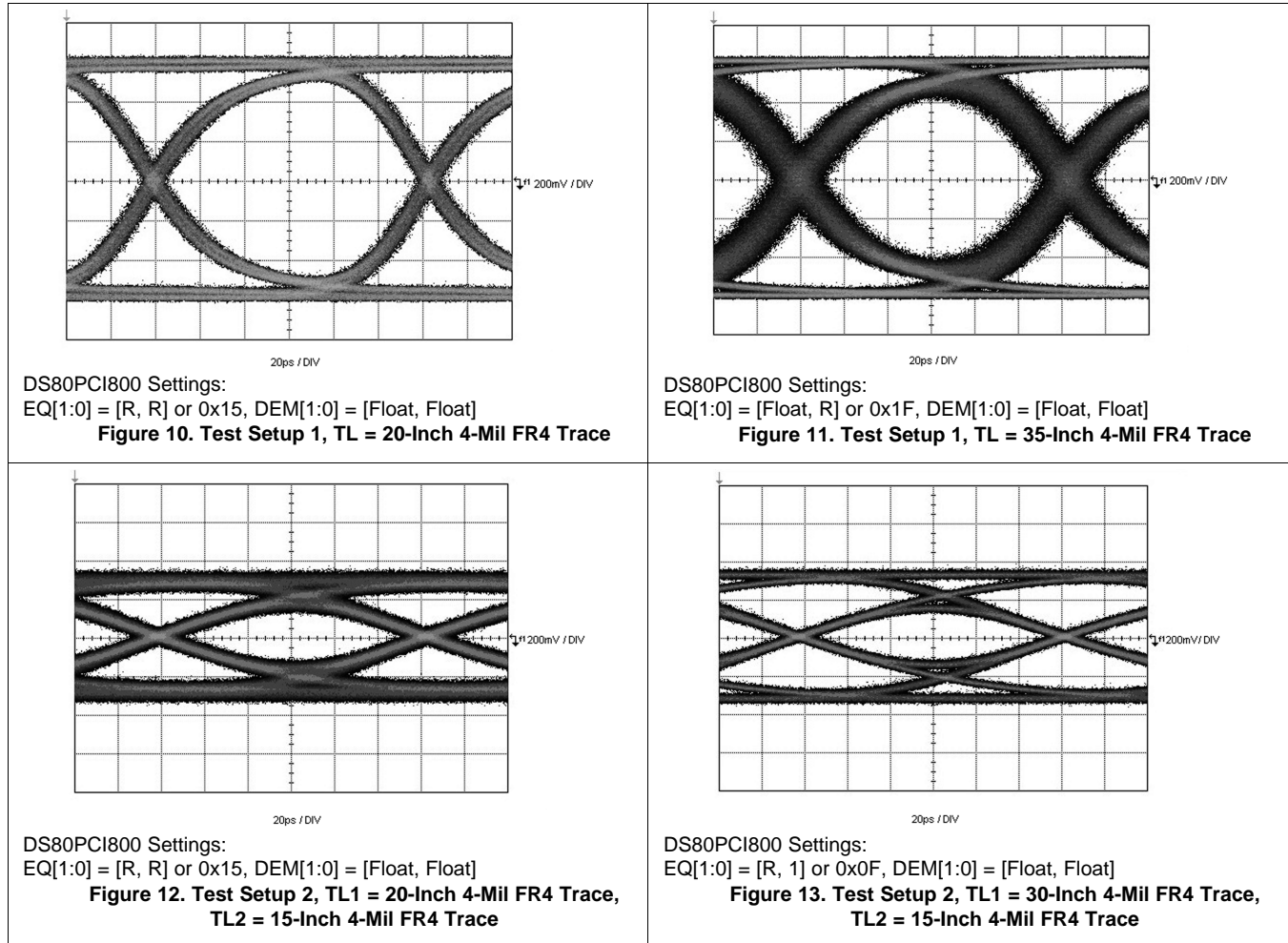
9.2.3 Application Curves

10 Power Supply Recommendations

10.1 3.3-V or 2.5-V Supply Mode Operation

The DS80PCI800 has an optional internal voltage regulator to provide the 2.5 V supply to the device. In 3.3-V mode, the VIN pin = 3.3 V is used to supply power to the device and the VDD pins should be left open. The internal regulator will provide the 2.5 V to the VDD pins of the device and a 0.1 μ F cap is needed at each of the five VDD pins for power supply de-coupling (total capacitance should be \leq 0.5 μ F), and the VDD pins should be left open. The VDD_SEL pin must be tied to GND to enable the internal regulator. In 2.5-V mode, the VIN pin should be left open and 2.5 V supply must be applied to the VDD pins. The VDD_SEL pin must be left open (no connect) to disable the internal regulator.

The DS80PCI800 can be configured for 2.5 V operation or 3.3 V operation. The lists below outline required connections for each supply selection.

3.3-V Mode of Operation

1. Tie VDD_SEL = 0 with 1-k Ω resistor to GND.
2. Feed 3.3-V supply into VIN pin. Local 1.0- μ F decoupling at VIN is recommended.
3. See information on VDD bypass below.
4. SDA and SCL pins should connect pullup resistor to VIN
5. Any 4-Level input which requires a connection to "Logic 1" should use a 1-k Ω resistor to VIN

2.5-V Mode of Operation

1. VDD_SEL = Float
2. VIN = Float
3. Feed 2.5-V supply into VDD pins.
4. See information on VDD bypass below.
5. SDA and SCL pins connect pullup resistor to VDD for 2.5-V uC SMBus IO
6. SDA and SCL pins connect pullup resistor to VDD for 3.3-V uC SMBus IO
7. Any 4-Level input which requires a connection to "Logic 1" should use a 1-k Ω resistor to VIN

DS80PCI800

SNLS334G – APRIL 2011 – REVISED JANUARY 2015

www.ti.com

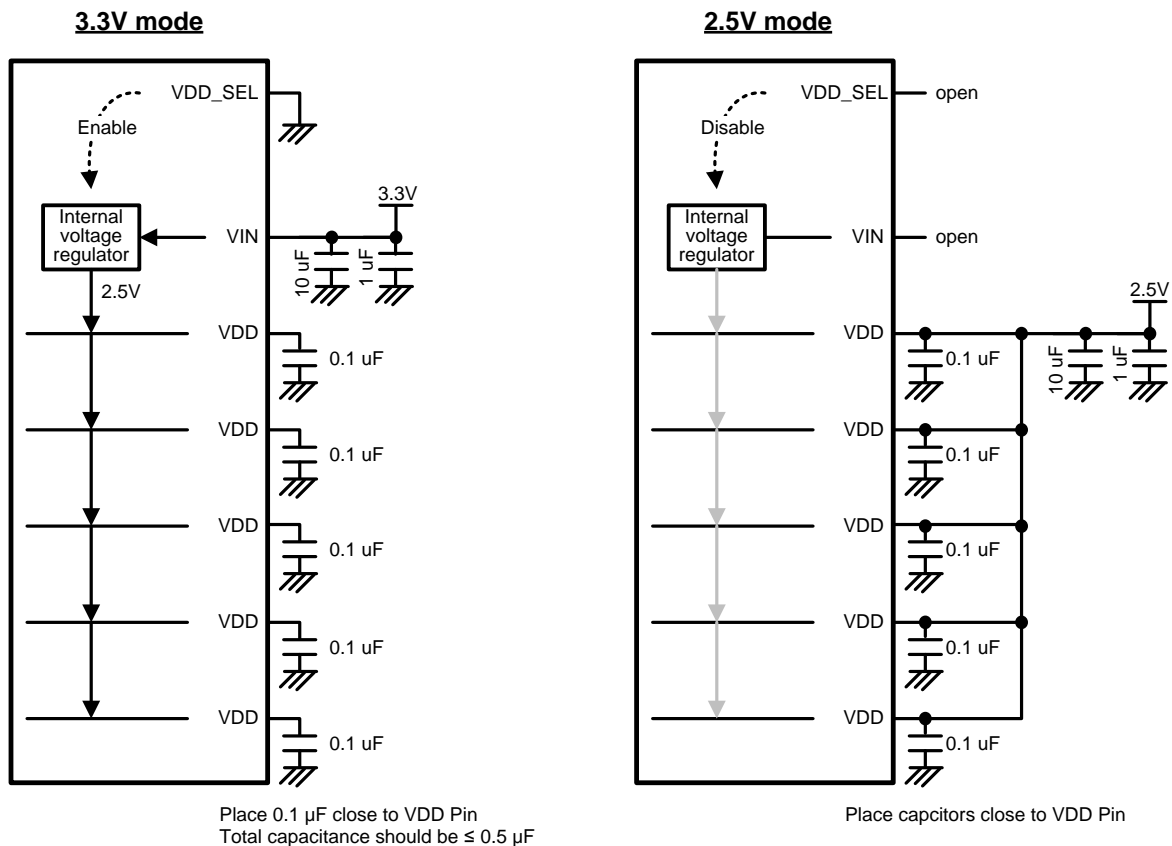
3.3-V or 2.5-V Supply Mode Operation (continued)**Figure 14. 3.3 V or 2.5 V Supply Connection Diagram****10.2 Power Supply Bypassing**

Two approaches are recommended to ensure that the DS80PCI800 is provided with an adequate power supply bypass. First, the supply (VDD) and ground (GND) pins should be connected to power planes routed on adjacent layers of the printed circuit board. Second, careful attention to supply bypassing through the proper use of bypass capacitors is required. A 0.1- μF bypass capacitor should be connected to each VDD pin such that the capacitor is placed as close as possible to the device. Small body size capacitors (such as 0402) reduce the parasitic inductance of the capacitor and also help in placement close to the VDD pin. If possible, the layer thickness of the dielectric should be minimized so that the VDD and GND planes create a low inductance supply with distributed capacitance.

11 Layout

11.1 Layout Guidelines

11.1.1 PCB Layout Considerations for Differential Pairs

The differential inputs and outputs are designed with 100 Ω differential terminations. Therefore, they should be connected to interconnects with controlled differential impedance of approximately 85-110 Ω . It is preferable to route differential lines primarily on one layer of the board, particularly for the input traces. The use of vias should be avoided if possible. If vias must be used, they should be used sparingly and must be placed symmetrically for each side of a given differential pair. Whenever differential vias are used, the layout must also provide for a low inductance path for the return currents as well. Route the differential signals away from other signals and noise sources on the printed circuit board. To minimize the effects of crosstalk, a 5:1 ratio or greater should be maintained between inter-pair spacing and trace width. See AN-1187 *Leadless Leadframe Package (LLP) Application Report (SNOA401)* for additional information on QFN (WQFN) packages.

The DS80PCI800 pinout promotes easy high speed routing and layout. To optimize DS80PCI800 performance refer to the following guidelines:

1. Place local VIN and VDD capacitors as close as possible to the device supply pins. Often the best location is directly under the DS80PCI800 pins to reduce the inductance path to the capacitor. In addition, bypass capacitors may share a via with the DAP GND to minimize ground loop inductance.
2. Differential pairs going into or out of the DS80PCI800 should have adequate pair-to-pair spacing to minimize crosstalk.
3. Use return current via connections to link reference planes locally. This ensures a low inductance return current path when the differential signal changes layers.
4. Optimize the via structure to minimize trace impedance mismatch.
5. Place GND vias around the DAP perimeter to ensure optimal electrical and thermal performance.
6. Use small body size AC coupling capacitors when possible — 0402 or smaller size is preferred. The AC coupling capacitors should be placed closer to the Rx on the channel.

Figure 15 depicts different transmission line topologies which can be used in various combinations to achieve the optimal system performance. Impedance discontinuities at the differential via can be minimized or eliminated by increasing the swell around each hole and providing for a low inductance return current path. When the via structure is associated with thick backplane PCB, further optimization such as back drilling is often used to reduce the detrimental high-frequency effects of stubs on the signal path.

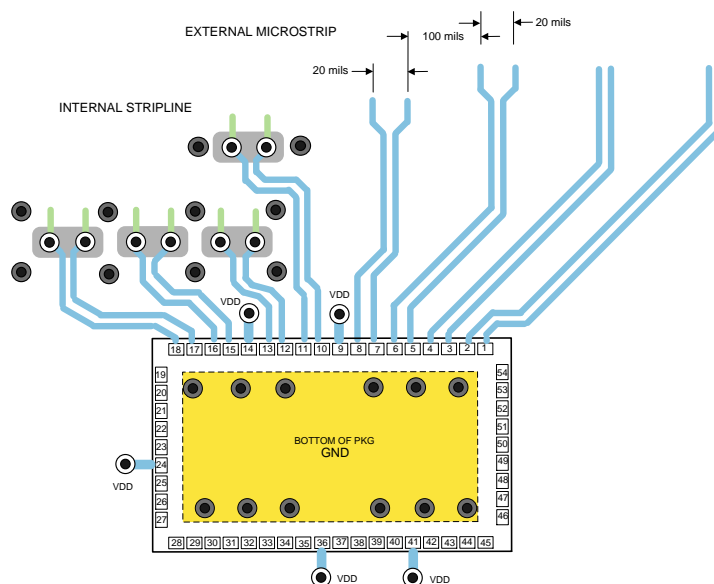

Figure 15. Typical Routing Options

DS80PCI800

SNLS334G – APRIL 2011 – REVISED JANUARY 2015

www.ti.com

12 Device and Documentation Support

12.1 Device Support

12.1.1 Third-Party Products Disclaimer

TI'S PUBLICATION OF INFORMATION REGARDING THIRD-PARTY PRODUCTS OR SERVICES DOES NOT CONSTITUTE AN ENDORSEMENT REGARDING THE SUITABILITY OF SUCH PRODUCTS OR SERVICES OR A WARRANTY, REPRESENTATION OR ENDORSEMENT OF SUCH PRODUCTS OR SERVICES, EITHER ALONE OR IN COMBINATION WITH ANY TI PRODUCT OR SERVICE.

12.2 Trademarks

PCI-Express is a trademark of PCI-SIG.

All other trademarks are the property of their respective owners.

12.3 Electrostatic Discharge Caution



These devices have limited built-in ESD protection. The leads should be shorted together or the device placed in conductive foam during storage or handling to prevent electrostatic damage to the MOS gates.

12.4 Glossary

[SLYZ022](#) — *TI Glossary*.

This glossary lists and explains terms, acronyms, and definitions.

13 Mechanical, Packaging, and Orderable Information

The following pages include mechanical, packaging, and orderable information. This information is the most current data available for the designated devices. This data is subject to change without notice and revision of this document. For browser-based versions of this data sheet, refer to the left-hand navigation.

PACKAGING INFORMATION

Orderable part number	Status (1)	Material type (2)	Package Pins	Package qty Carrier	RoHS (3)	Lead finish/ Ball material (4)	MSL rating/ Peak reflow (5)	Op temp (°C)	Part marking (6)
DS80PCI800SQ/NOPB	Active	Production	WQFN (NJY) 54	2000 LARGE T&R	Yes	SN	Level-2-260C-1 YEAR	-40 to 85	DS80PCI800SQ
DS80PCI800SQ/NOPB.A	Active	Production	WQFN (NJY) 54	2000 LARGE T&R	Yes	SN	Level-2-260C-1 YEAR	-40 to 85	DS80PCI800SQ
DS80PCI800SQ/NOPB.B	Active	Production	WQFN (NJY) 54	2000 LARGE T&R	Yes	SN	Level-2-260C-1 YEAR	-40 to 85	DS80PCI800SQ
DS80PCI800SQE/NOPB	Active	Production	WQFN (NJY) 54	250 SMALL T&R	Yes	SN	Level-2-260C-1 YEAR	-40 to 85	DS80PCI800SQ
DS80PCI800SQE/NOPB.A	Active	Production	WQFN (NJY) 54	250 SMALL T&R	Yes	SN	Level-2-260C-1 YEAR	-40 to 85	DS80PCI800SQ
DS80PCI800SQE/NOPB.B	Active	Production	WQFN (NJY) 54	250 SMALL T&R	Yes	SN	Level-2-260C-1 YEAR	-40 to 85	DS80PCI800SQ

(1) **Status:** For more details on status, see our [product life cycle](#).

(2) **Material type:** When designated, preproduction parts are prototypes/experimental devices, and are not yet approved or released for full production. Testing and final process, including without limitation quality assurance, reliability performance testing, and/or process qualification, may not yet be complete, and this item is subject to further changes or possible discontinuation. If available for ordering, purchases will be subject to an additional waiver at checkout, and are intended for early internal evaluation purposes only. These items are sold without warranties of any kind.

(3) **RoHS values:** Yes, No, RoHS Exempt. See the [TI RoHS Statement](#) for additional information and value definition.

(4) **Lead finish/Ball material:** Parts may have multiple material finish options. Finish options are separated by a vertical ruled line. Lead finish/Ball material values may wrap to two lines if the finish value exceeds the maximum column width.

(5) **MSL rating/Peak reflow:** The moisture sensitivity level ratings and peak solder (reflow) temperatures. In the event that a part has multiple moisture sensitivity ratings, only the lowest level per JEDEC standards is shown. Refer to the shipping label for the actual reflow temperature that will be used to mount the part to the printed circuit board.

(6) **Part marking:** There may be an additional marking, which relates to the logo, the lot trace code information, or the environmental category of the part.

Multiple part markings will be inside parentheses. Only one part marking contained in parentheses and separated by a "~" will appear on a part. If a line is indented then it is a continuation of the previous line and the two combined represent the entire part marking for that device.

Important Information and Disclaimer: The information provided on this page represents TI's knowledge and belief as of the date that it is provided. TI bases its knowledge and belief on information provided by third parties, and makes no representation or warranty as to the accuracy of such information. Efforts are underway to better integrate information from third parties. TI has taken and continues to take reasonable steps to provide representative and accurate information but may not have conducted destructive testing or chemical analysis on incoming materials and chemicals. TI and TI suppliers consider certain information to be proprietary, and thus CAS numbers and other limited information may not be available for release.

In no event shall TI's liability arising out of such information exceed the total purchase price of the TI part(s) at issue in this document sold by TI to Customer on an annual basis.

TAPE AND REEL INFORMATION

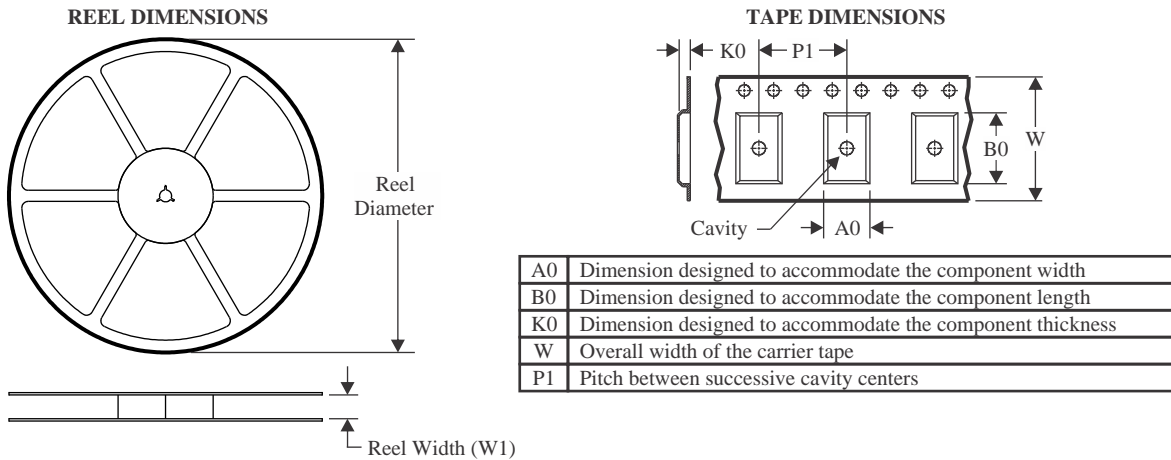

QUADRANT ASSIGNMENTS FOR PIN 1 ORIENTATION IN TAPE

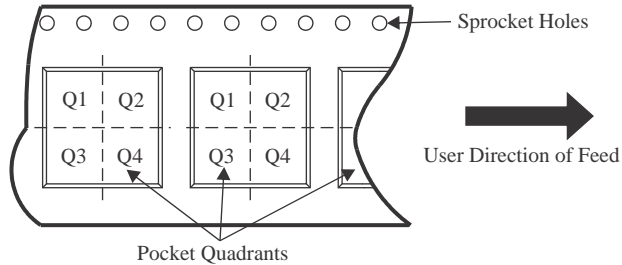

*All dimensions are nominal

Device	Package Type	Package Drawing	Pins	SPQ	Reel Diameter (mm)	Reel Width W1 (mm)	A0 (mm)	B0 (mm)	K0 (mm)	P1 (mm)	W (mm)	Pin1 Quadrant
DS80PCI800SQ/NOPB	WQFN	NJY	54	2000	330.0	16.4	5.8	10.3	1.0	12.0	16.0	Q1
DS80PCI800SQE/NOPB	WQFN	NJY	54	250	178.0	16.4	5.8	10.3	1.0	12.0	16.0	Q1

TAPE AND REEL BOX DIMENSIONS

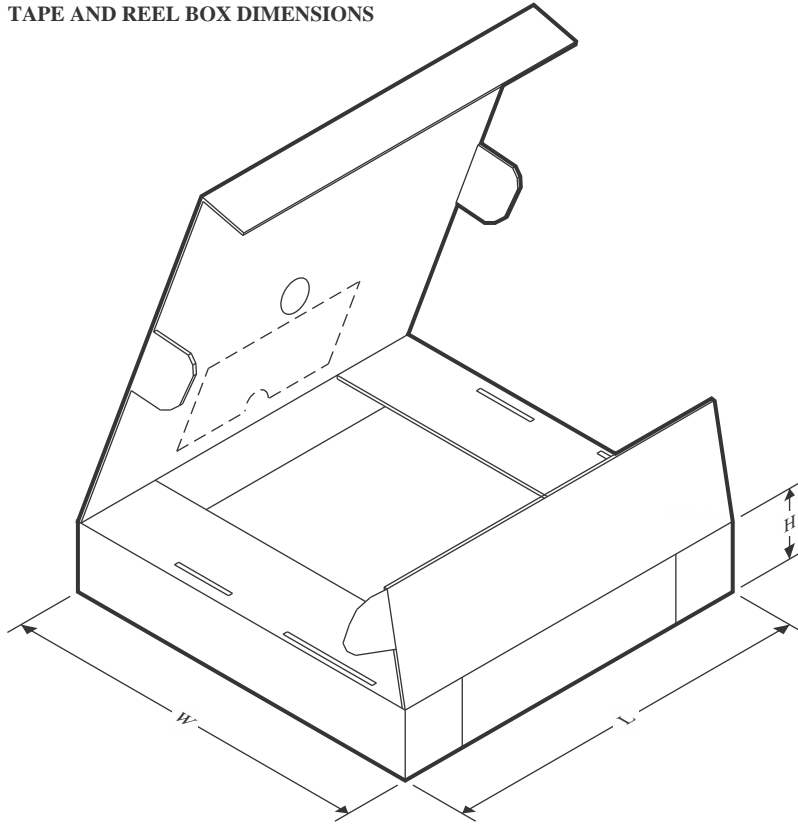

*All dimensions are nominal

Device	Package Type	Package Drawing	Pins	SPQ	Length (mm)	Width (mm)	Height (mm)
DS80PCI800SQ/NOPB	WQFN	NJY	54	2000	356.0	356.0	36.0
DS80PCI800SQE/NOPB	WQFN	NJY	54	250	208.0	191.0	35.0

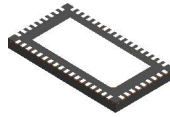

NJY0054A

WQFN

WQFN

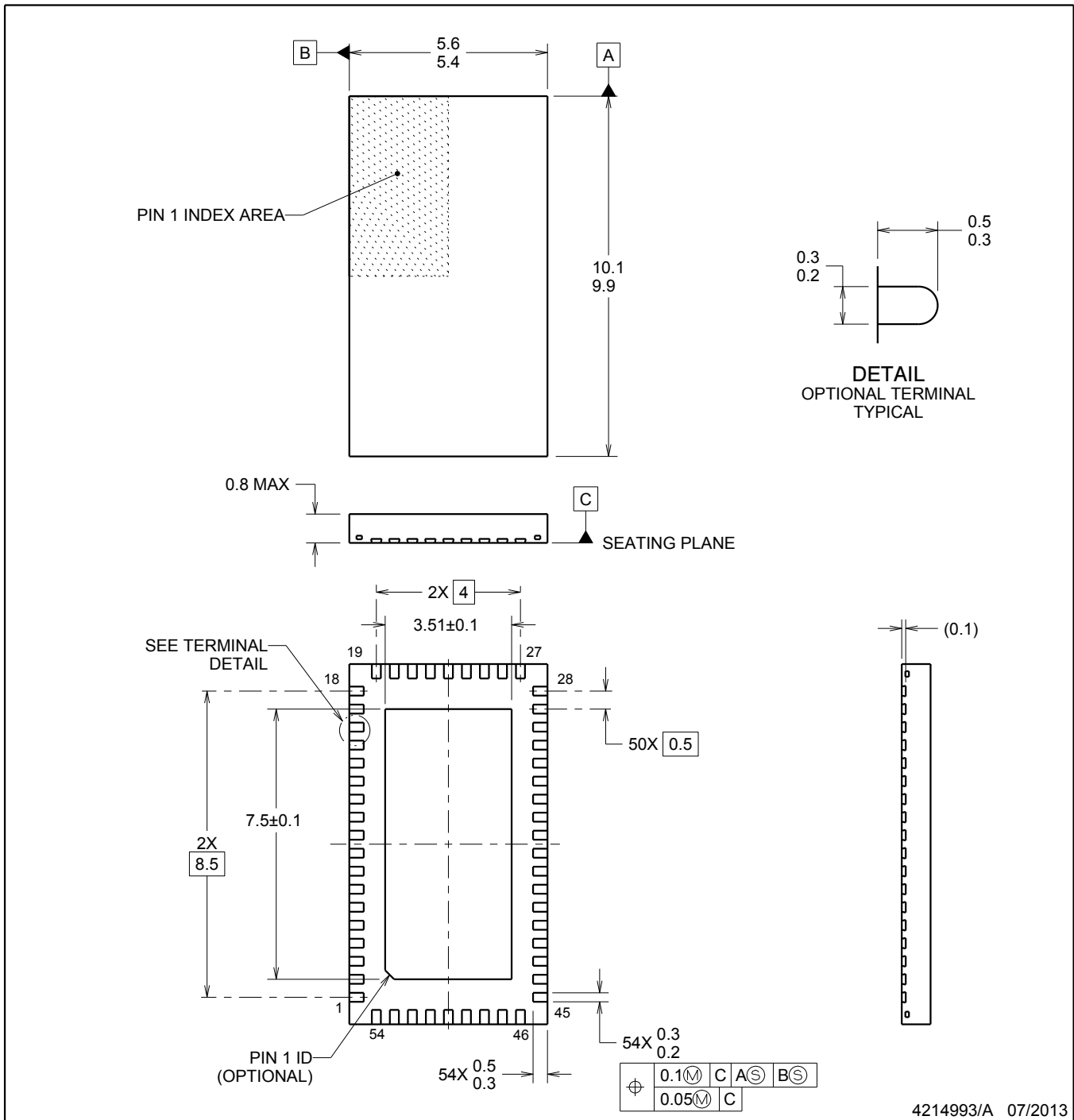

NOTES:

1. All linear dimensions are in millimeters. Dimensions in parenthesis are for reference only. Dimensioning and tolerancing per ASME Y14.5M.
2. This drawing is subject to change without notice.
3. The package thermal pad must be soldered to the printed circuit board for thermal and mechanical performance.

NJY0054A

WQFN

WQFN

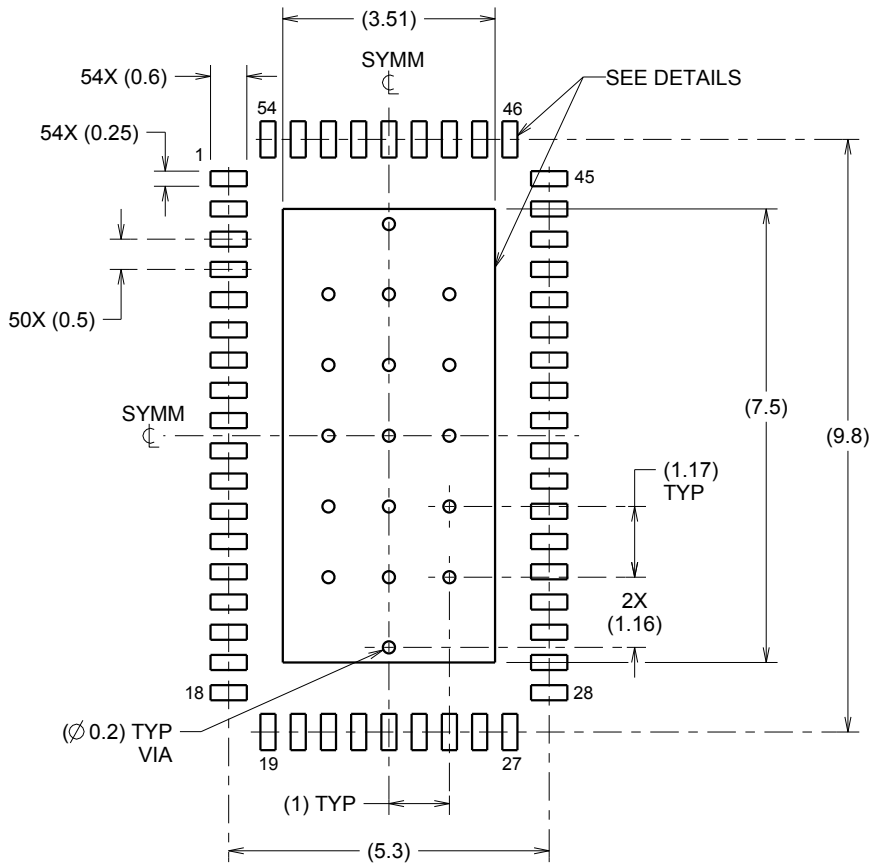

LAND PATTERN EXAMPLE
SCALE:8X

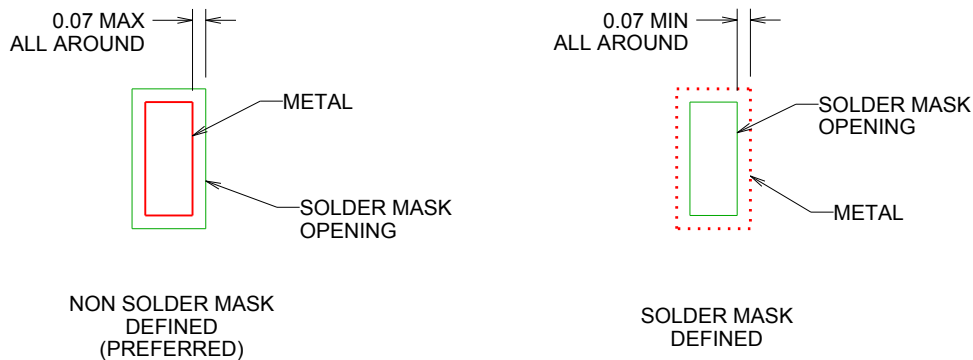

SOLDER MASK DETAILS

4214993/A 07/2013

NOTES: (continued)

4. This package is designed to be soldered to a thermal pad on the board. For more information, refer to QFN/SON PCB application note in literature No. SLUA271 (www.ti.com/lit/slua271).

NJY0054A

WQFN

WQFN

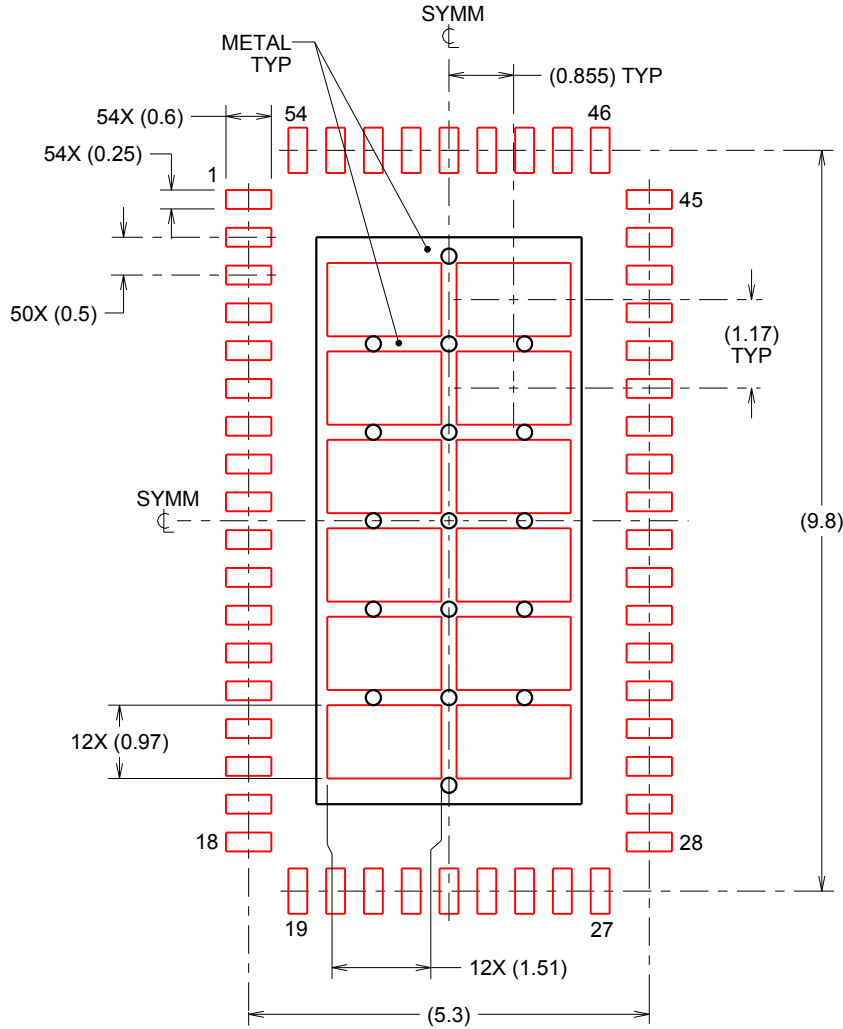

SOLDERPASTE EXAMPLE
 BASED ON 0.125mm THICK STENCIL

EXPOSED PAD
 67% PRINTED SOLDER COVERAGE BY AREA
 SCALE:10X

4214993/A 07/2013

NOTES: (continued)

- 5. Laser cutting apertures with trapezoidal walls and rounded corners may offer better paste release. IPC-7525 may have alternate design recommendations.

IMPORTANT NOTICE AND DISCLAIMER

TI PROVIDES TECHNICAL AND RELIABILITY DATA (INCLUDING DATASHEETS), DESIGN RESOURCES (INCLUDING REFERENCE DESIGNS), APPLICATION OR OTHER DESIGN ADVICE, WEB TOOLS, SAFETY INFORMATION, AND OTHER RESOURCES "AS IS" AND WITH ALL FAULTS, AND DISCLAIMS ALL WARRANTIES, EXPRESS AND IMPLIED, INCLUDING WITHOUT LIMITATION ANY IMPLIED WARRANTIES OF MERCHANTABILITY, FITNESS FOR A PARTICULAR PURPOSE OR NON-INFRINGEMENT OF THIRD PARTY INTELLECTUAL PROPERTY RIGHTS.

These resources are intended for skilled developers designing with TI products. You are solely responsible for (1) selecting the appropriate TI products for your application, (2) designing, validating and testing your application, and (3) ensuring your application meets applicable standards, and any other safety, security, regulatory or other requirements.

These resources are subject to change without notice. TI grants you permission to use these resources only for development of an application that uses the TI products described in the resource. Other reproduction and display of these resources is prohibited. No license is granted to any other TI intellectual property right or to any third party intellectual property right. TI disclaims responsibility for, and you fully indemnify TI and its representatives against any claims, damages, costs, losses, and liabilities arising out of your use of these resources.

TI's products are provided subject to [TI's Terms of Sale](#), [TI's General Quality Guidelines](#), or other applicable terms available either on ti.com or provided in conjunction with such TI products. TI's provision of these resources does not expand or otherwise alter TI's applicable warranties or warranty disclaimers for TI products. Unless TI explicitly designates a product as custom or customer-specified, TI products are standard, catalog, general purpose devices.

TI objects to and rejects any additional or different terms you may propose.

Copyright © 2025, Texas Instruments Incorporated

Last updated 10/2025

OUR CERTIFICATE

DiGi provide top-quality products and perfect service for customer worldwide through standardization, technological innovation and continuous improvement. DiGi through third-party certification, we stricly control the quality of products and services. Welcome your RFQ to

Email: Info@DiGi-Electronics.com



Tel: +00 852-30501935

RFQ Email: Info@DiGi-Electronics.com

DiGi is a global authorized distributor of electronic components.