

ISO7240CFDW Datasheet



<https://www.DiGi-Electronics.com>

| | |
|------------------------------|--|
| DiGi Electronics Part Number | ISO7240CFDW-DG |
| Manufacturer | Texas Instruments |
| Manufacturer Product Number | ISO7240CFDW |
| Description | DGTL ISO 2500VRMS 4CH GP 16SOIC |
| Detailed Description | General Purpose Digital Isolator 2500Vrms 4 Channel 25Mbps 25kV/ μ s CMTI 16-SOIC (0.295", 7.50mm Width) |



Tel: +00 852-30501935

RFQ Email: Info@DiGi-Electronics.com

DiGi is a global authorized distributor of electronic components.

Purchase and inquiry

Manufacturer Product Number:

ISO7240CFDW

Series:

-

Technology:

Capacitive Coupling

Isolated Power:

No

Inputs - Side 1/Side 2:

4/0

Voltage - Isolation:

2500Vrms

Data Rate:

25Mbps

Pulse Width Distortion (Max):

2.5ns

Voltage - Supply:

3.15V ~ 5.5V

Mounting Type:

Surface Mount

Supplier Device Package:

16-SOIC

Manufacturer:

Texas Instruments

Product Status:

Last Time Buy

Type:

General Purpose

Number of Channels:

4

Channel Type:

Unidirectional

Common Mode Transient Immunity (Min):

25kV/ μ s

Propagation Delay tpLH / tpHL (Max):

42ns, 42ns

Rise / Fall Time (Typ):

2ns, 2ns

Operating Temperature:

-40°C ~ 125°C

Package / Case:

16-SOIC (0.295", 7.50mm Width)

Base Product Number:

ISO7240

Environmental & Export classification

RoHS Status:

ROHS3 Compliant

REACH Status:

REACH Unaffected

HTSUS:

8542.39.0001

Moisture Sensitivity Level (MSL):

2 (1 Year)

ECCN:

EAR99

ISO724x High-Speed, Quad-Channel Digital Isolators

1 Features

- 25 and 150Mbps Signaling Rate Options
 - Low Channel-to-Channel Output Skew; 1ns Maximum
 - Low Pulse-Width Distortion (PWD); 2ns Maximum
 - Low Jitter Content; 1ns Typ at 150Mbps
- Selectable Default Output (ISO7240CF)
- > 25-Year Life at Rated Working Voltage (see [Isolation Lifetime Projection](#))
- 4-kV ESD Protection
- Operates With 3.3V or 5V Supplies
- High Electromagnetic Immunity
- –40°C to +125°C Operating Temperature Range
- [Safety-Related Certifications](#):
 - DIN EN IEC 60747-17 (VDE 0884-17)
 - UL 1577 component recognition program
 - IEC 61010-1, IEC 62368-1 certifications

2 Applications

- [Factory Automation](#)
 - [Modbus](#)
 - [Profibus™](#)
 - [DeviceNet™ Data Buses](#)
- [Computer Peripheral Interface](#)
- [Servo Control Interface](#)
- [Data Acquisition](#)

3 Description

The ISO7240x, ISO7241x, and ISO7242x devices are quad-channel digital isolators with multiple channel configurations and output-enable functions. These devices have logic-input and logic-output buffers separated by Texas Instrument's silicon-dioxide (SiO₂) isolation barrier. Used in conjunction with isolated power supplies, these devices help block high voltage, isolate grounds, and prevent noise currents from entering the local ground and interfering with or damaging sensitive circuitry.

The ISO7240x family of devices has all four channels in the same direction. The ISO7241x family of devices has three channels in the same direction and one channel in the opposition direction. The ISO7242x family of devices has two channels in each direction.

The devices with the C suffix (C option) have TTL input thresholds and a noise-filter at the input that prevents transient pulses from being passed to the output of the device. The devices with the M suffix (M option) have CMOS $V_{CC}/2$ input thresholds and do not have the input noise filter or the additional propagation delay.

The ISO7240CF device has an input disable function on pin 7, and a selectable high or low failsafe-output function with the CTRL pin (pin 10). The failsafe output is a logic high when a logic high is placed on the CTRL pin or the pin is left unconnected. If a logic low signal is applied to the CTRL pin, the failsafe output becomes a logic-low output state. The input disable function of the ISO7240CF device prevents data from being passed across the isolation barrier to the output. When the inputs are disabled or V_{CC1} is powered down, the outputs are set by the CTRL pin.

These devices can be powered from 3.3V or 5V supplies on either side, in any combination. The signal input pins are 5V tolerant regardless of the voltage supply level that is used.

These devices are characterized for operation over the ambient temperature range of –40°C to +125°C.



ISO7240CF, ISO7240C, ISO7240M, ISO7241C, ISO7241M, ISO7242C, ISO7242M

SLLS868W – SEPTEMBER 2007 – REVISED OCTOBER 2025

Package Information

| PART NUMBER | PACKAGE ⁽¹⁾ | BODY SIZE (NOM) | PACKAGE SIZE ⁽²⁾ |
|-------------|------------------------|------------------|-----------------------------|
| ISO7240CF | DW (SOIC, 16) | 10.30mm × 7.50mm | 10.30mm × 10.30mm |
| ISO7240C | | | |
| ISO7240M | | | |
| ISO7241C | | | |
| ISO7241M | | | |
| ISO7242C | | | |
| ISO7242M | | | |

- (1) For all available packages, see the orderable addendum at the end of the data sheet.
(2) The package size (length × width) is a nominal value and includes pins, where applicable.

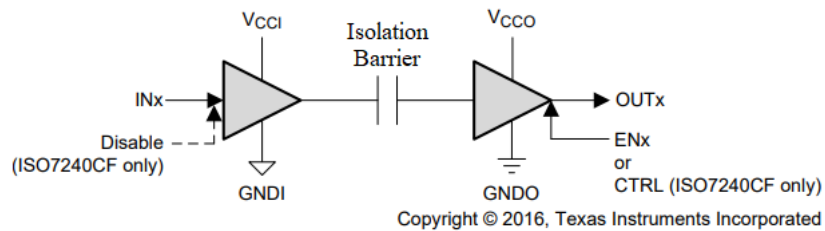

V_{CCI} and GNDI are supply and ground connections respectively for the input channels.

V_{CCO} and GND0 are supply and ground connections respectively for the output channels.

Simplified Schematic

Table of Contents

| | | | |
|--|----|--|----|
| 1 Features | 1 | 5.18 Switching Characteristics: V_{CC1} at 5-V, V_{CC2} at 3.3-V Operation..... | 13 |
| 2 Applications | 1 | 5.19 Switching Characteristics: V_{CC1} at 3.3-V and V_{CC2} at 5-V Operation..... | 14 |
| 3 Description | 1 | 5.20 Switching Characteristics: V_{CC1} and V_{CC2} at 3.3-V Operation..... | 14 |
| 4 Pin Configurations and Functions | 4 | 5.21 Insulation Characteristics Curves..... | 15 |
| 5 Specifications | 5 | 5.22 Typical Characteristics..... | 16 |
| 5.1 Absolute Maximum Ratings..... | 5 | 6 Parameter Measurement Information | 18 |
| 5.2 ESD Ratings..... | 5 | 7 Detailed Description | 21 |
| 5.3 Recommended Operating Conditions..... | 5 | 7.1 Overview..... | 21 |
| 5.4 Thermal Information..... | 6 | 7.2 Functional Block Diagram..... | 21 |
| 5.5 Power Ratings..... | 6 | 7.3 Feature Description..... | 22 |
| 5.6 Insulation Specifications..... | 7 | 7.4 Device Functional Modes..... | 22 |
| 5.7 Safety-Related Certifications..... | 7 | 8 Application and Implementation | 23 |
| 5.8 Safety Limiting Values..... | 8 | 8.1 Application Information..... | 23 |
| 5.9 Electrical Characteristics: V_{CC1} and V_{CC2} at 5-V Operation..... | 9 | 8.2 Typical Application..... | 23 |
| 5.10 Supply Current Characteristics: V_{CC1} and V_{CC2} at 5-V Operation..... | 9 | 8.3 Power Supply Recommendations..... | 27 |
| 5.11 Electrical Characteristics: V_{CC1} at 5-V, V_{CC2} at 3.3-V Operation..... | 10 | 8.4 Layout..... | 28 |
| 5.12 Supply Current Characteristics: V_{CC1} at 5-V, V_{CC2} at 3.3-V Operation..... | 10 | 9 Device and Documentation Support | 29 |
| 5.13 Electrical Characteristics: V_{CC1} at 3.3-V, V_{CC2} at 5-V Operation..... | 11 | 9.1 Documentation Support..... | 29 |
| 5.14 Supply Current Characteristics: V_{CC1} at 3.3-V, V_{CC2} at 5-V Operation..... | 11 | 9.2 Receiving Notification of Documentation Updates..... | 29 |
| 5.15 Electrical Characteristics: V_{CC1} and V_{CC2} at 3.3 V Operation..... | 12 | 9.3 Support Resources..... | 29 |
| 5.16 Supply Current Characteristics: V_{CC1} and V_{CC2} at 3.3 V Operation..... | 12 | 9.4 Trademarks..... | 29 |
| 5.17 Switching Characteristics: V_{CC1} and V_{CC2} at 5-V Operation..... | 13 | 9.5 Electrostatic Discharge Caution..... | 29 |
| | | 9.6 Glossary..... | 29 |
| | | 10 Revision History | 29 |
| | | 11 Mechanical, Packaging, and Orderable Information | 30 |

4 Pin Configurations and Functions

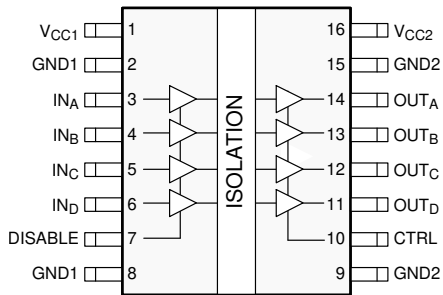

Figure 4-1. ISO7240CF DW Package 16-Pin SOIC Top View

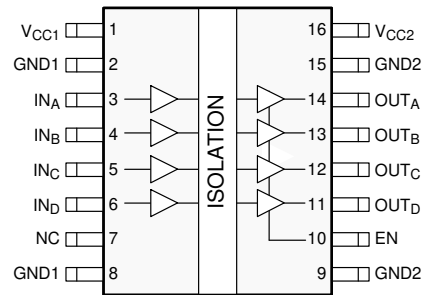

Figure 4-2. ISO7240C DW Package 16-Pin SOIC Top View

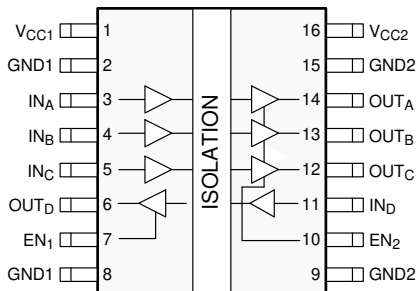

Figure 4-3. ISO7241C DW Package 16-Pin SOIC Top View

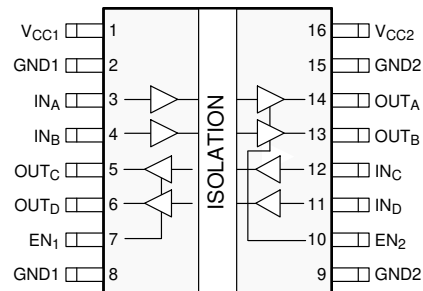

Figure 4-4. ISO7242C DW Package 16-Pin SOIC Top View

Table 4-1. Pin Functions

| NAME | PIN NO. | | | | Type ⁽¹⁾ | DESCRIPTION ³ |
|------------------|-----------|----------|----------|----------|---------------------|--|
| | ISO7240CF | ISO7240C | ISO7241C | ISO7242C | | |
| CTRL | 10 | — | — | — | I | Failsafe output control. Output state is determined by CTRL pin when DISABLE is high or V _{CC1} is powered down. Output is high when CTRL is high or open and low when CTRL is low. |
| DISABLE | 7 | — | — | — | I | Input disable. All input pins are disabled when DISABLE is high and enabled when DISABLE is low or open. |
| EN | — | 10 | — | — | I | Output enable. All output pins are enabled when EN is high or open and disabled when EN is low. |
| EN ₁ | — | — | 7 | 7 | I | Output enable 1. Output pins on side 1 are enabled when EN ₁ is high or open and disabled when EN ₁ is low. |
| EN ₂ | — | — | 10 | 10 | I | Output enable 2. Output pins on side-2 are enabled when EN ₂ is high or open and disabled when EN ₂ is low. |
| GND1 | 2, 8 | 2, 8 | 2, 8 | 2, 8 | — | Ground connection for V _{CC1} |
| GND2 | 9, 15 | 9, 15 | 9, 15 | 9, 15 | — | Ground connection for V _{CC2} |
| IN _A | 3 | 3 | 3 | 3 | I | Input, channel A |
| IN _B | 4 | 4 | 4 | 4 | I | Input, channel B |
| IN _C | 5 | 5 | 5 | 12 | I | Input, channel C |
| IN _D | 6 | 6 | 11 | 11 | I | Input, channel D |
| NC | — | 7 | — | — | — | No Connect pins are floating with no internal connection |
| OUT _A | 14 | 14 | 14 | 14 | O | Output, channel A |
| OUT _B | 13 | 13 | 13 | 13 | O | Output, channel B |
| OUT _C | 12 | 12 | 12 | 5 | O | Output, channel C |
| OUT _D | 11 | 11 | 6 | 6 | O | Output, channel D |
| V _{CC1} | 1 | 1 | 1 | 1 | — | Power supply, V _{CC1} |
| V _{CC2} | 16 | 16 | 16 | 16 | — | Power supply, V _{CC2} |

(1) I = Input; O = Output

5 Specifications

5.1 Absolute Maximum Ratings

See (1)

| | | MIN | MAX | UNIT |
|------------------|---|------|--------------------------------------|------|
| V _{CC} | Supply voltage ⁽²⁾ , V _{CC1} , V _{CC2} | -0.5 | 6 | V |
| V _I | Voltage at IN, OUT, EN, DISABLE, CTRL | -0.5 | V _{CC} + 0.5 ⁽³⁾ | V |
| I _O | Output current | -15 | 15 | mA |
| T _J | Maximum junction temperature | | 170 | °C |
| T _{stg} | Storage temperature | -65 | 150 | °C |

- Operation outside the Absolute Maximum Ratings may cause permanent device damage. Absolute Maximum Ratings do not imply functional operation of the device at these or any other conditions beyond those listed under Recommended Operating Conditions. If used outside the Recommended Operating Conditions but within the Absolute Maximum Ratings, the device may not be fully functional, and this may affect device reliability, functionality, performance, and shorten the device lifetime.
- All voltage values except differential I/O bus voltages are with respect to the local ground terminal (GND1 or GND2) and are peak voltage values.
- Maximum voltage must not exceed 6 V.

5.2 ESD Ratings

| | | VALUE | UNIT |
|--------------------|-------------------------|--|-------|
| V _(ESD) | Electrostatic discharge | Human body model (HBM), per ANSI/ESDA/JEDEC JS-001 ⁽¹⁾ | ±4000 |
| | | Charged device model (CDM), per JEDEC specification JESD22-C101 ⁽²⁾ | ±1000 |

- JEDEC document JEP155 states that 500-V HBM allows safe manufacturing with a standard ESD control process.
- JEDEC document JEP157 states that 250-V CDM allows safe manufacturing with a standard ESD control process.

5.3 Recommended Operating Conditions

| | | | MIN | NOM | MAX | UNIT |
|-------------------|---|----------|-----------------------|--------------------|-----------------------|------|
| V _{CC} | Supply voltage ⁽²⁾ , V _{CC1} , V _{CC2} | | 3.15 | | 5.5 | V |
| I _{OH} | High-level output current | | -4 | | | mA |
| I _{OL} | Low-level output current | | | | 4 | mA |
| t _{ui} | Input pulse width | ISO724xC | 40 | | | ns |
| | | ISO724xM | 6.67 | 5 | | |
| 1/t _{ui} | Signaling rate | ISO724xC | 0 | 30 ⁽¹⁾ | 25 | Mbps |
| | | ISO724xM | 0 | 200 ⁽¹⁾ | 150 | |
| V _{IH} | High-level input voltage (IN) | ISO724xM | 0.7 × V _{CC} | | V _{CC} | V |
| V _{IL} | Low-level input voltage (IN) | | 0 | | 0.3 × V _{CC} | V |
| V _{IH} | High-level input voltage (IN, DISABLE, CTRL, EN on all devices) | ISO724xC | 2 | | 5.5 | V |
| V _{IL} | Low-level input voltage (IN, DISABLE, CTRL, EN on all devices) | | 0 | | 0.8 | V |
| T _J | Junction temperature | | | | 150 | °C |
| H | External magnetic field-strength immunity per IEC 61000-4-8 and IEC 61000-4-9 certification | | | | 1000 | A/m |

- Typical value at room temperature and well-regulated power supply.
- For the 5-V operation, V_{CC1} or V_{CC2} is specified from 4.5 V to 5.5 V.
For the 3.3-V operation, V_{CC1} or V_{CC2} is specified from 3.15 V to 3.6 V.

ISO7240CF, ISO7240C, ISO7240M, ISO7241C, ISO7241M, ISO7242C, ISO7242M

SLLS868W – SEPTEMBER 2007 – REVISED OCTOBER 2025

5.4 Thermal Information

| THERMAL METRIC ⁽¹⁾ | | | ISO724xx | UNIT |
|-------------------------------|--|--------------|-----------|------|
| | | | DW (SOIC) | |
| | | | 16 PINS | |
| R _{θJA} | Junction-to-ambient thermal resistance | Low-K board | 168 | °C/W |
| | | High-K board | 68.6 | °C/W |
| R _{θJC(top)} | Junction-to-case (top) thermal resistance | | 33.9 | °C/W |
| R _{θJB} | Junction-to-board thermal resistance | | 33.5 | °C/W |
| ψ _{JT} | Junction-to-top characterization parameter | | 14.8 | °C/W |
| ψ _{JB} | Junction-to-board characterization parameter | | 32.9 | °C/W |
| R _{θJC(bot)} | Junction-to-case (bottom) thermal resistance | | n/a | °C/W |

(1) For more information about traditional and new thermal metrics, see the [Semiconductor and IC Package Thermal Metrics](#) application note.

5.5 Power Ratings

V_{CC1} = V_{CC2} = 5.5 V, T_J = 150C, C_L = 15 pF, Input a 50% duty cycle 25-Mbps square wave (unless otherwise noted)

| PARAMETER | | TEST CONDITIONS | MIN | TYP | MAX | UNIT |
|----------------|---------------------------|-----------------|-----|-----|-----|------|
| P _D | Maximum power dissipation | | | | 220 | mW |

5.6 Insulation Specifications

| PARAMETER | | TEST CONDITIONS | VALUE | UNIT |
|---|--|--|-------------------|------------------|
| GENERAL | | | | |
| CLR | External clearance ⁽¹⁾ | Shortest terminal-to-terminal distance through air | 8 | mm |
| CPG | External creepage ⁽¹⁾ | Shortest terminal-to-terminal distance across the package surface | 8 | mm |
| DTI | Distance through the insulation | Minimum internal gap (internal clearance) | 0.008 | mm |
| CTI | Comparative tracking index | DIN EN 60112 (VDE 0884-17); IEC 60112 | ≥400 | V |
| | Material group | | II | |
| | Overvoltage Category | Rated mains voltage ≤ 150 V _{RMS} | I-IV | |
| | | Rated mains voltage ≤ 300 V _{RMS} | I-III | |
| DIN EN IEC 60747-17 (VDE 0884-17):⁽²⁾ | | | | |
| V _{IORM} | Maximum repetitive peak isolation voltage | AC voltage (bipolar) | 560 | V _{PK} |
| V _{IOTM} | Maximum transient isolation voltage | V _{TEST} = V _{IOTM} , t = 60 s (qualification); V _{TEST} = 1.2 × V _{IOTM} , t = 1 s (100% production) | 4000 | V _{PK} |
| q _{pd} | Apparent charge ⁽³⁾ | Method a: After I/O safety test subgroup 2/3. V _{ini} = V _{IOTM} , t _{ini} = 60 s; V _{pd(m)} = 1.2 × V _{IORM} , t _m = 10 s, | ≤5 | pC |
| | | Method a: After environmental tests subgroup 1, V _{ini} = V _{IOTM} , t _{ini} = 60 s; V _{pd(m)} = 1.3 × V _{IORM} , t _m = 10 s, | ≤5 | |
| | | Method b: At routine test (100% production) V _{ini} = 1.2 × V _{IOTM} , t _{ini} = 1 s; V _{pd(m)} = 1.5 × V _{IORM} , t _m = 1 s (method b1) or V _{pd(m)} = V _{ini} , t _m = t _{ini} (method b2) | ≤5 | |
| C _{IO} | Barrier capacitance, input to output ⁽⁴⁾ | V _I = 0.4 sin(2πft), f = 1 MHz | 2 | pF |
| R _{IO} | Isolation resistance, input to output ⁽⁴⁾ | V _{IO} = 500 V, T _A = 25°C | >10 ¹² | Ω |
| | | V _{IO} = 500 V, 100°C ≤ T _A ≤ 125°C | >10 ¹¹ | |
| | | V _{IO} = 500 V at T _S = 150°C | >10 ⁹ | |
| | Pollution degree | | 2 | |
| | Climatic category | | 40/125/21 | |
| UL 1577 | | | | |
| V _{ISO} | Withstand isolation voltage | V _{TEST} = V _{ISO} = 2500 V _{RMS} , t = 60 s (qualification); V _{TEST} = 1.2 × V _{ISO} = 3000 V _{RMS} , t = 1 s (100% production) | 2500 | V _{RMS} |

- (1) Creepage and clearance requirements should be applied according to the specific equipment isolation standards of an application. Care should be taken to maintain the creepage and clearance distance of a board design to ensure that the mounting pads of the isolator on the printed-circuit board do not reduce this distance. Creepage and clearance on a printed-circuit board become equal in certain cases. Techniques such as inserting grooves and/or ribs on a printed circuit board are used to help increase these specifications.
- (2) This coupler is suitable for *basic electrical insulation* only within the maximum operating ratings. Compliance with the safety ratings shall be ensured by means of suitable protective circuits.
- (3) Apparent charge is electrical discharge caused by a partial discharge (pd).
- (4) All pins on each side of the barrier tied together creating a two-terminal device

5.7 Safety-Related Certifications

| VDE | CSA | UL |
|--|------------------------------------|--|
| Certified according to DIN EN IEC 60747-17 (VDE 0884-17) | Certified according to IEC 62368-1 | Certified according to UL 1577 Component Recognition Program |
| Basic certificate: 40047657 | Master contract number: 220991 | File number: E181974 |

5.8 Safety Limiting Values

Safety limiting⁽¹⁾ intends to minimize potential damage to the isolation barrier upon failure of input or output circuitry. A failure of the I/O can allow low resistance to ground or the supply and, without current limiting, dissipate sufficient power to overheat the die and damage the isolation barrier, potentially leading to secondary system failures.

| PARAMETER | | TEST CONDITIONS | MIN | TYP | MAX | UNIT |
|----------------|---|---|-----|-----|-----|------|
| I _S | Safety input, output, or supply current | R _{θJA} = 168°C/W, V _I = 5.5 V, T _J = 170°C, T _A = 25°C, see Figure 5-2 | | | 156 | mA |
| | | R _{θJA} = 168°C/W, V _I = 3.6 V, T _J = 170°C, T _A = 25°C, see Figure 5-2 | | | 239 | |
| T _S | Safety temperature | | | | 150 | °C |

- (1) The safety-limiting constraint is the maximum junction temperature specified in the data sheet. The power dissipation and junction-to-air [thermal impedance](#) of the device installed in the application hardware determines the junction temperature. The assumed junction-to-air thermal resistance in the table is that of a device installed on a high-K test board for leaded surface-mount packages. The power is the recommended maximum input voltage times the current. The junction temperature is then the ambient temperature plus the power times the junction-to-air thermal resistance.

5.9 Electrical Characteristics: V_{CC1} and V_{CC2} at 5-V Operation

For the 5-V operation, V_{CC1} or V_{CC2} is specified from 4.5 V to 5.5 V. Over recommended operating conditions (unless otherwise noted)

| PARAMETER | | TEST CONDITIONS | MIN | TYP | MAX | UNIT |
|--------------|--------------------------------|--|-----------------|-----|-----|-------------|
| I_{OFF} | Sleep mode output current | EN at 0 V, Single channel | | 0 | | μ A |
| V_{OH} | High-level output voltage | $I_{OH} = -4$ mA, See Figure 6-1 | $V_{CCO} - 0.8$ | | | V |
| | | $I_{OH} = -20$ μ A, See Figure 6-1 | $V_{CCO} - 0.1$ | | | |
| V_{OL} | Low-level output voltage | $I_{OL} = 4$ mA, See Figure 6-1 | | | 0.4 | V |
| | | $I_{OL} = 20$ μ A, See Figure 6-1 | | | 0.1 | |
| $V_{I(HYS)}$ | Input voltage hysteresis | | | 150 | | mV |
| I_{IH} | High-level input current | IN at V_{CC1} | | | 10 | μ A |
| I_{IL} | Low-level input current | IN at 0 V | -10 | | | |
| C_1 | Input capacitance to ground | IN at V_{CC} , $V_I = 0.4 \sin(2\pi ft)$, $f = 2$ MHz | | 2 | | pF |
| CMTI | Common-mode transient immunity | $V_I = V_{CC}$ or 0 V, See Figure 6-5 | 25 | 50 | | kV/ μ s |

5.10 Supply Current Characteristics: V_{CC1} and V_{CC2} at 5-V Operation

For the 5-V operation, V_{CC1} or V_{CC2} is specified from 4.5 V to 5.5 V. Over recommended operating conditions (unless otherwise noted)

| PARAMETER | | TEST CONDITIONS | MIN | TYP | MAX | UNIT |
|-------------------|------------------------|--|--------------------------------------|-----|------|------|
| ISO7240C/M | | | | | | |
| I_{CC1} | Supply current, side 1 | Quiescent, All channels, no load, EN at 3 V, $V_I = V_{CC}$ or 0 V | | 1 | 3 | mA |
| | | 25 Mbps, All channels, no load, EN at 3 V, 12.5-MHz input-clock signal | | 7 | 10.5 | |
| I_{CC2} | Supply current, side 2 | All channels, no load, EN at 3 V | Quiescent, $V_I = V_{CC}$ or 0 V | 15 | 22 | mA |
| | | | 25 Mbps, 12.5-MHz input-clock signal | 17 | 25 | |
| ISO7241C/M | | | | | | |
| I_{CC1} | Supply current, side 1 | All channels, no load, EN ₁ at 3 V, EN ₂ at 3 V | Quiescent, $V_I = V_{CC}$ or 0 V | 6.5 | 11 | mA |
| | | | 25 Mbps, 12.5-MHz input-clock signal | 12 | 18 | |
| I_{CC2} | Supply current, side 2 | All channels, no load, EN ₁ at 3 V, EN ₂ at 3 V | Quiescent, $V_I = V_{CC}$ or 0 V | 13 | 20 | mA |
| | | | 25 Mbps, 12.5-MHz input-clock signal | 18 | 28 | |
| ISO7242C/M | | | | | | |
| I_{CC1} | Supply current, side 1 | All channels, no load, EN ₁ at 3 V, EN ₂ at 3 V | Quiescent, $V_I = V_{CC}$ or 0 V | 10 | 16 | mA |
| | | | 25 Mbps, 12.5-MHz input-clock signal | 15 | 24 | |
| I_{CC2} | Supply current, side 2 | All channels, no load, EN ₁ at 3 V, EN ₂ at 3 V | Quiescent, $V_I = V_{CC}$ or 0 V | 10 | 16 | mA |
| | | | 25 Mbps, 12.5-MHz input-clock signal | 15 | 24 | |

ISO7240CF, ISO7240C, ISO7240M, ISO7241C, ISO7241M, ISO7242C, ISO7242M

SLLS868W – SEPTEMBER 2007 – REVISED OCTOBER 2025

5.11 Electrical Characteristics: V_{CC1} at 5-V, V_{CC2} at 3.3-V Operation

For the 5-V operation, V_{CC1} or V_{CC2} is specified from 4.5 V to 5.5 V. For the 3.3-V operation, V_{CC1} or V_{CC2} is specified from 3.15 V to 3.6 V. Over recommended operating conditions (unless otherwise noted)

| PARAMETER | | TEST CONDITIONS | | MIN | TYP | MAX | UNIT |
|--------------|--------------------------------|--|---|-----------------|-----|-------------|---------|
| I_{OFF} | Sleep mode output current | EN at 0 V, Single channel | | 0 | | | μ A |
| V_{OH} | High-level output voltage | $I_{OH} = -4$ mA, See Figure 6-1 | 3.3-V side | $V_{CC0} - 0.4$ | | V | |
| | | | 5-V side | $V_{CC0} - 0.8$ | | | |
| V_{OL} | Low-level output voltage | $I_{OH} = -20$ μ A, See Figure 6-1 | | $V_{CC0} - 0.1$ | | V | |
| | | | $I_{OL} = 4$ mA, See Figure 6-1 | 0.4 | | | |
| V_{OL} | Low-level output voltage | $I_{OL} = 20$ μ A, See Figure 6-1 | | 0.1 | | V | |
| $V_{I(HYS)}$ | Input voltage hysteresis | | | 150 | | mV | |
| I_{IH} | High-level input current | IN at V_{CC1} | | | | 10 | |
| I_{IL} | Low-level input current | IN at 0 V | | -10 | | μ A | |
| C_1 | Input capacitance to ground | IN at V_{CC} , $V_I = 0.4 \sin(2\pi ft)$, $f=2$ MHz | | 2 | | pF | |
| CMTI | Common-mode transient immunity | $V_I = V_{CC}$ or 0 V, See Figure 6-5 | | 25 | 50 | kV/ μ s | |

5.12 Supply Current Characteristics: V_{CC1} at 5-V, V_{CC2} at 3.3-V Operation

For the 5-V operation, V_{CC1} or V_{CC2} is specified from 4.5 V to 5.5 V. For the 3.3-V operation, V_{CC1} or V_{CC2} is specified from 3.15 V to 3.6 V. Over recommended operating conditions (unless otherwise noted)

| PARAMETER | | TEST CONDITIONS | | MIN | TYP | MAX | UNIT |
|-------------------|------------------------|---|--------------------------------------|------|------|-----|------|
| ISO7240C/M | | | | | | | |
| I_{CC1} | Supply current, side 1 | All channels, no load, EN at 3 V | Quiescent, $V_I = V_{CC}$ or 0 V | 1 | 3 | mA | |
| | | | 25 Mbps, 12.5-MHz input-clock signal | 7 | 10.5 | | |
| I_{CC2} | Supply current, side 2 | All channels, no load, EN at 3 V | Quiescent, $V_I = V_{CC}$ or 0 V | 9.5 | 15 | mA | |
| | | | 25 Mbps, 12.5-MHz input-clock signal | 10.5 | 17 | | |
| ISO7241C/M | | | | | | | |
| I_{CC1} | Supply current, side 1 | All channels, no load, EN ₁ at 3 V, EN ₂ at 3 V | Quiescent, $V_I = V_{CC}$ or 0 V | 6.5 | 11 | mA | |
| | | | 12.5-MHz input-clock signal | 12 | 18 | | |
| I_{CC2} | Supply current, side 2 | All channels, no load, EN ₁ at 3 V, EN ₂ at 3 V | Quiescent, $V_I = V_{CC}$ or 0 V | 8 | 13 | mA | |
| | | | 25 Mbps, 12.5-MHz input-clock signal | 11.5 | 18 | | |
| ISO7242C/M | | | | | | | |
| I_{CC1} | Supply current, side 1 | All channels, no load, EN ₁ at 3 V, EN ₂ at 3 V | Quiescent, $V_I = V_{CC}$ or 0 V | 10 | 16 | mA | |
| | | | 12.5-MHz input-clock signal | 15 | 24 | | |
| I_{CC2} | Supply current, side 2 | All channels, no load, EN ₁ at 3 V, EN ₂ at 3 V | Quiescent, $V_I = V_{CC}$ or 0 V | 6 | 10 | mA | |
| | | | 25 Mbps, 12.5-MHz input-clock signal | 9 | 14 | | |

5.13 Electrical Characteristics: V_{CC1} at 3.3-V, V_{CC2} at 5-V Operation

For the 5-V operation, V_{CC1} or V_{CC2} is specified from 4.5 V to 5.5 V. For the 3.3-V operation, V_{CC1} or V_{CC2} is specified from 3.15 V to 3.6 V. Over recommended operating conditions (unless otherwise noted)

| PARAMETER | | TEST CONDITIONS | | MIN | TYP | MAX | UNIT |
|--------------|--------------------------------|--|---|-----------------|-----|-----|-------------|
| I_{OFF} | Sleep mode output current | EN at 0 V, Single channel | | 0 | | | μ A |
| V_{OH} | High-level output voltage | $I_{OH} = -4$ mA, See Figure 6-1 | 3.3-V side | $V_{CCO} - 0.4$ | | V | |
| | | | 5-V side | $V_{CCO} - 0.8$ | | | |
| | | $I_{OH} = -20$ μ A, See Figure 6-1 | $V_{CCO} - 0.1$ | | | | |
| V_{OL} | Low-level output voltage | $I_{OL} = 4$ mA, See Figure 6-1 | | | 0.4 | V | |
| | | | $I_{OL} = 20$ μ A, See Figure 6-1 | | | | 0.1 |
| $V_{I(HYS)}$ | Input voltage hysteresis | | | 150 | | mV | |
| I_{IH} | High-level input current | IN at V_{CC1} | | | | 10 | μ A |
| I_{IL} | Low-level input current | IN at 0 V | | -10 | | | |
| C_1 | Input capacitance to ground | IN at V_{CC} , $V_I = 0.4 \sin(2\pi ft)$, $f=2$ MHz | | 2 | | | pF |
| CMTI | Common-mode transient immunity | $V_I = V_{CC}$ or 0 V, See Figure 6-5 | | 25 | 50 | | kV/ μ s |

5.14 Supply Current Characteristics: V_{CC1} at 3.3-V, V_{CC2} at 5-V Operation

For the 5-V operation, V_{CC1} or V_{CC2} is specified from 4.5 V to 5.5 V. For the 3.3-V operation, V_{CC1} or V_{CC2} is specified from 3.15 V to 3.6 V. Over recommended operating conditions (unless otherwise noted)

| PARAMETER | | TEST CONDITIONS | | MIN | TYP | MAX | UNIT |
|-------------------|------------------------|---|--------------------------------------|-----|-----|-----|------|
| ISO7240C/M | | | | | | | |
| I_{CC1} | Supply current, side 1 | All channels, no load, EN at 3 V | Quiescent, $V_I = V_{CC}$ or 0 V | | 0.5 | 1.2 | mA |
| | | | 25 Mbps, 12.5-MHz input-clock signal | | 3 | 5 | |
| I_{CC2} | Supply current, side 2 | All channels, no load, EN at 3 V | Quiescent, $V_I = V_{CC}$ or 0 V | | 15 | 22 | mA |
| | | | 25 Mbps, 12.5-MHz input-clock signal | | 17 | 25 | |
| ISO7241C/M | | | | | | | |
| I_{CC1} | Supply current, side 1 | All channels, no load, EN ₁ at 3 V, EN ₂ at 3 V | Quiescent, $V_I = V_{CC}$ or 0 V | | 4 | 7 | mA |
| | | | 25 Mbps, 12.5-MHz input-clock signal | | 6.5 | 11 | |
| I_{CC2} | Supply current, side 2 | All channels, no load, EN ₁ at 3 V, EN ₂ at 3 V | Quiescent, $V_I = V_{CC}$ or 0 V | | 13 | 20 | mA |
| | | | 25 Mbps, 12.5-MHz input-clock signal | | 18 | 28 | |
| ISO7242C/M | | | | | | | |
| I_{CC1} | Supply current, side 1 | All channels, no load, EN ₁ at 3 V, EN ₂ at 3 V | Quiescent, $V_I = V_{CC}$ or 0 V | | 6 | 10 | mA |
| | | | 25 Mbps, 12.5-MHz input-clock signal | | 9 | 14 | |
| I_{CC2} | Supply current, side 2 | All channels, no load, EN ₁ at 3 V, EN ₂ at 3 V | Quiescent, $V_I = V_{CC}$ or 0 V | | 10 | 16 | mA |
| | | | 25 Mbps, 12.5-MHz input-clock signal | | 15 | 24 | |

ISO7240CF, ISO7240C, ISO7240M, ISO7241C, ISO7241M, ISO7242C, ISO7242M

SLLS868W – SEPTEMBER 2007 – REVISED OCTOBER 2025

5.15 Electrical Characteristics: V_{CC1} and V_{CC2} at 3.3 V Operation

For the 3.3-V operation, V_{CC1} or V_{CC2} is specified from 3.15 V to 3.6 V. Over recommended operating conditions (unless otherwise noted)

| PARAMETER | | TEST CONDITIONS | MIN | TYP | MAX | UNIT |
|--------------|--------------------------------|--|-----------------|-----|-----|-------------|
| I_{OFF} | Sleep mode output current | EN at 0 V, single channel | | 0 | | μ A |
| V_{OH} | High-level output voltage | $I_{OH} = -4$ mA, See Figure 6-1 | $V_{CCO} - 0.4$ | | | V |
| | | $I_{OH} = -20$ μ A, See Figure 6-1 | $V_{CCO} - 0.1$ | | | |
| V_{OL} | Low-level output voltage | $I_{OL} = 4$ mA, See Figure 6-1 | | | 0.4 | V |
| | | $I_{OL} = 20$ μ A, See Figure 6-1 | | | 0.1 | |
| $V_{I(HYS)}$ | Input voltage hysteresis | | | 150 | | mV |
| I_{IH} | High-level input current | IN at V_{CC1} | | | 10 | μ A |
| I_{IL} | Low-level input current | IN at 0 V | -10 | | | |
| C_1 | Input capacitance to ground | IN at V_{CC} , $V_I = 0.4 \sin(2\pi ft)$, $f=2$ MHz | | 2 | | pF |
| CMTI | Common-mode transient immunity | $V_I = V_{CC}$ or 0 V, See Figure 6-5 | 25 | 50 | | kV/ μ s |

5.16 Supply Current Characteristics: V_{CC1} and V_{CC2} at 3.3 V Operation

For the 3.3-V operation, V_{CC1} or V_{CC2} is specified from 3.15 V to 3.6 V. Over recommended operating conditions (unless otherwise noted)

| PARAMETER | | TEST CONDITIONS | MIN | TYP | MAX | UNIT | |
|-------------------|------------------------|---|--------------------------------------|-----|------|------|----|
| ISO7240C/M | | | | | | | |
| I_{CC1} | Supply current, side 1 | All channels, no load, EN at 3 V | Quiescent, $V_I = V_{CC}$ or 0 V | | 0.5 | 1.2 | mA |
| | | | 25 Mbps, 12.5-MHz input-clock signal | | 3 | 5 | |
| I_{CC2} | Supply current, side 2 | All channels, no load, EN at 3 V | Quiescent, $V_I = V_{CC}$ or 0 V | | 9.5 | 15 | mA |
| | | | 25 Mbps, 12.5-MHz input-clock signal | | 10.5 | 17 | |
| ISO7241C/M | | | | | | | |
| I_{CC1} | Supply current, side 1 | All channels, no load, EN ₁ at 3 V, EN ₂ at 3 V | Quiescent, $V_I = V_{CC}$ or 0 V | | 4 | 7 | mA |
| | | | 25 Mbps, 12.5-MHz input-clock signal | | 6.5 | 11 | |
| I_{CC2} | Supply current, side 2 | All channels, no load, EN ₁ at 3 V, EN ₂ at 3 V | Quiescent, $V_I = V_{CC}$ or 0 V | | 8 | 13 | mA |
| | | | 25 Mbps, 12.5-MHz input-clock signal | | 11.5 | 18 | |
| ISO7242C/M | | | | | | | |
| I_{CC1} | Supply current, side 1 | All channels, no load, EN ₁ at 3 V, EN ₂ at 3 V | Quiescent, $V_I = V_{CC}$ or 0 V | | 6 | 10 | mA |
| | | | 25 Mbps, 12.5-MHz input-clock signal | | 9 | 14 | |
| I_{CC2} | Supply current, side 2 | All channels, no load, EN ₁ at 3 V, EN ₂ at 3 V | Quiescent, $V_I = V_{CC}$ or 0 V | | 6 | 10 | mA |
| | | | 25 Mbps, 12.5-MHz input-clock signal | | 9 | 14 | |

5.17 Switching Characteristics: V_{CC1} and V_{CC2} at 5-V Operation

over recommended operating conditions (unless otherwise noted)

| PARAMETER | | TEST CONDITIONS | MIN | TYP | MAX | UNIT |
|-----------------------|---|-----------------|--|-----|-----|---------|
| t_{PLH} , t_{PHL} | Propagation delay | ISO724xC | 18 | | 42 | ns |
| PWD | Pulse-width distortion ⁽¹⁾ $ t_{PHL} - t_{PLH} $ | | | | | |
| t_{PLH} , t_{PHL} | Propagation delay | ISO724xM | 8 | | 23 | ns |
| PWD | Pulse-width distortion ⁽¹⁾ $ t_{PHL} - t_{PLH} $ | | | | | |
| $t_{sk(pp)}$ | Part-to-part skew ⁽²⁾ | ISO724xC | | | 8 | ns |
| | | ISO724xM | | 0 | 3 | |
| $t_{sk(o)}$ | Channel-to-channel output skew ⁽³⁾ | ISO724xC | | | 2 | ns |
| | | ISO724xM | | 0 | 1 | |
| t_r | Output signal rise time | See Figure 6-1 | | | 2.4 | ns |
| t_f | Output signal fall time | | | | | |
| t_{PHZ} | Propagation delay, high-level-to-high-impedance output | See Figure 6-2 | | | 15 | 25 |
| t_{PZH} | Propagation delay, high-impedance-to-high-level output | | | | 15 | 25 |
| t_{PLZ} | Propagation delay, low-level-to-high-impedance output | | | | 15 | 25 |
| t_{PZL} | Propagation delay, high-impedance-to-low-level output | | | | 15 | 25 |
| t_{fs} | Failsafe output delay time from input power loss | See Figure 6-3 | | | 12 | μ s |
| t_{wake} | Wake time from input disable | See Figure 6-4 | | | 15 | μ s |
| $t_{jit(pp)}$ | Peak-to-peak eye-pattern jitter | ISO724xM | 150 Mbps NRZ data input, Same polarity input on all channels, See Figure 6-6 | | 1 | ns |

(1) Also referred to as pulse skew.

(2) $t_{sk(pp)}$ is the magnitude of the difference in propagation delay times between any specified terminals of two devices when both devices operate with the same supply voltages, at the same temperature, and have identical packages and test circuits.

(3) $t_{sk(o)}$ is the skew between specified outputs of a single device with all driving inputs connected together and the outputs switching in the same direction while driving identical specified loads.

5.18 Switching Characteristics: V_{CC1} at 5-V, V_{CC2} at 3.3-V Operation

over recommended operating conditions (unless otherwise noted)

| PARAMETER | | TEST CONDITIONS | MIN | TYP | MAX | UNIT |
|-----------------------|---|-----------------|---|-----|-----|---------|
| t_{PLH} , t_{PHL} | Propagation delay | ISO724xC | 20 | | 50 | ns |
| PWD | Pulse-width distortion ⁽¹⁾ $ t_{PHL} - t_{PLH} $ | | | | | |
| t_{PLH} , t_{PHL} | Propagation delay | ISO724xM | 8 | | 29 | ns |
| PWD | Pulse-width distortion ⁽¹⁾ $ t_{PHL} - t_{PLH} $ | | | | | |
| $t_{sk(pp)}$ | Part-to-part skew ⁽²⁾ | ISO724xC | | | 10 | ns |
| | | ISO724xM | | 0 | 5 | |
| $t_{sk(o)}$ | Channel-to-channel output skew ⁽³⁾ | ISO724xC | | | 3 | ns |
| | | ISO724xM | | 0 | 1 | |
| t_r | Output signal rise time | See Figure 6-1 | | | 2.4 | ns |
| t_f | Output signal fall time | | | | | |
| t_{PHZ} | Propagation delay, high-level-to-high-impedance output | See Figure 6-2 | | | 15 | 25 |
| t_{PZH} | Propagation delay, high-impedance-to-high-level output | | | | 15 | 25 |
| t_{PLZ} | Propagation delay, low-level-to-high-impedance output | | | | 15 | 25 |
| t_{PZL} | Propagation delay, high-impedance-to-low-level output | | | | 15 | 25 |
| t_{fs} | Failsafe output delay time from input power loss | See Figure 6-3 | | | 18 | μ s |
| t_{wake} | Wake time from input disable | See Figure 6-4 | | | 15 | μ s |
| $t_{jit(pp)}$ | Peak-to-peak eye-pattern jitter | ISO724xM | 150 Mbps PRBS NRZ data input, Same polarity input on all channels, See Figure 6-6 | | 1 | ns |

(1) Also known as pulse skew

ISO7240CF, ISO7240C, ISO7240M, ISO7241C, ISO7241M, ISO7242C, ISO7242M

SLLS868W – SEPTEMBER 2007 – REVISED OCTOBER 2025

- (2) $t_{sk(pp)}$ is the magnitude of the difference in propagation delay times between any specified terminals of two devices when both devices operate with the same supply voltages, at the same temperature, and have identical packages and test circuits.
- (3) $t_{sk(o)}$ is the skew between specified outputs of a single device with all driving inputs connected together and the outputs switching in the same direction while driving identical specified loads.

5.19 Switching Characteristics: V_{CC1} at 3.3-V and V_{CC2} at 5-V Operation

over recommended operating conditions (unless otherwise noted)

| PARAMETER | | TEST CONDITIONS | | MIN | TYP | MAX | UNIT | | |
|-----------------------|---|-----------------|--|----------------|----------------|-----|---------|-----|----|
| t_{PLH} , t_{PHL} | Propagation delay | ISO724xC | See Figure 6-1 | 22 | | 51 | ns | | |
| PWD | Pulse-width distortion ⁽¹⁾ $ t_{PHL} - t_{PLH} $ | | | | | 3 | | | |
| t_{PLH} , t_{PHL} | Propagation delay | ISO724xM | | See Figure 6-1 | 8 | | 30 | ns | |
| PWD | Pulse-width distortion ⁽¹⁾ $ t_{PHL} - t_{PLH} $ | | | | | | 1 | | 2 |
| $t_{sk(pp)}$ | Part-to-part skew ⁽²⁾ | ISO724xC | | | See Figure 6-1 | | | 10 | ns |
| | | ISO724xM | | | | | | 0 | |
| $t_{sk(o)}$ | Channel-to-channel output skew ⁽³⁾ | ISO724xC | See Figure 6-1 | | | | | 2.5 | ns |
| | | ISO724xM | | | | | | 0 | |
| t_r | Output signal rise time | | | See Figure 6-1 | | | | 2.4 | ns |
| t_f | Output signal fall time | | | | | | | 2.3 | |
| t_{PHZ} | Propagation delay, high-level-to-high-impedance output | | | See Figure 6-2 | | | 15 | ns | |
| t_{PZH} | Propagation delay, high-impedance-to-high-level output | | | | | | 15 | | 25 |
| t_{PLZ} | Propagation delay, low-level-to-high-impedance output | | 15 | | | | 25 | | |
| t_{PZL} | Propagation delay, high-impedance-to-low-level output | | 15 | | | | 25 | | |
| t_{fs} | Failsafe output delay time from input power loss | | See Figure 6-3 | | | 12 | μ s | | |
| t_{wake} | Wake time from input disable | | See Figure 6-4 | | | 15 | μ s | | |
| $t_{jit(pp)}$ | Peak-to-peak eye-pattern jitter | ISO724xM | 150 Mbps NRZ data input, Same polarity input on all channels, See Figure 6-6 | | | 1 | ns | | |

- (1) Also known as pulse skew
- (2) $t_{sk(pp)}$ is the magnitude of the difference in propagation delay times between any specified terminals of two devices when both devices operate with the same supply voltages, at the same temperature, and have identical packages and test circuits.
- (3) $t_{sk(o)}$ is the skew between specified outputs of a single device with all driving inputs connected together and the outputs switching in the same direction while driving identical specified loads.

5.20 Switching Characteristics: V_{CC1} and V_{CC2} at 3.3-V Operation

over recommended operating conditions (unless otherwise noted)

| PARAMETER | | TEST CONDITIONS | | MIN | TYP | MAX | UNIT | | |
|-----------------------|---|-----------------|----------------|----------------|----------------|-----|---------|-----|----|
| t_{PLH} , t_{PHL} | Propagation delay | ISO724xC | See Figure 6-1 | 25 | | 56 | ns | | |
| PWD | Pulse-width distortion $ t_{PHL} - t_{PLH} $ ⁽¹⁾ | | | | | 4 | | | |
| t_{PLH} , t_{PHL} | Propagation delay | ISO724xM | | See Figure 6-1 | 8 | | 34 | ns | |
| PWD | Pulse-width distortion $ t_{PHL} - t_{PLH} $ ⁽¹⁾ | | | | | | 1 | | 2 |
| $t_{sk(pp)}$ | Part-to-part skew ⁽²⁾ | ISO724xC | | | See Figure 6-1 | | | 10 | ns |
| | | ISO724xM | | | | | | 0 | |
| $t_{sk(o)}$ | Channel-to-channel output skew ⁽³⁾ | ISO724xC | See Figure 6-1 | | | | | 3.5 | ns |
| | | ISO724xM | | | | | | 0 | |
| t_r | Output signal rise time | | | See Figure 6-1 | | | | 2.4 | ns |
| t_f | Output signal fall time | | | | | | | 2.3 | |
| t_{PHZ} | Propagation delay, high-level-to-high-impedance output | | | See Figure 6-2 | | | 15 | ns | |
| t_{PZH} | Propagation delay, high-impedance-to-high-level output | | | | | | 15 | | 25 |
| t_{PLZ} | Propagation delay, low-level-to-high-impedance output | | 15 | | | | 25 | | |
| t_{PZL} | Propagation delay, high-impedance-to-low-level output | | 15 | | | | 25 | | |
| t_{fs} | Failsafe output delay time from input power loss | | See Figure 6-3 | | | 18 | μ s | | |
| t_{wake} | Wake time from input disable | | See Figure 6-4 | | | 15 | μ s | | |

over recommended operating conditions (unless otherwise noted)

| PARAMETER | | | TEST CONDITIONS | MIN | TYP | MAX | UNIT |
|---------------|---------------------------------|----------|---|-----|-----|-----|------|
| $t_{jit(pp)}$ | Peak-to-peak eye-pattern jitter | ISO724xM | 150 Mbps PRBS NRZ data input, same polarity input on all channels, See Figure 6-6 | | 1 | | ns |

- (1) Also referred to as pulse skew.
- (2) $t_{sk(pp)}$ is the magnitude of the difference in propagation delay times between any specified terminals of two devices when both devices operate with the same supply voltages, at the same temperature, and have identical packages and test circuits.
- (3) $t_{sk(o)}$ is the skew between specified outputs of a single device with all driving inputs connected together and the outputs switching in the same direction while driving identical specified loads.

5.21 Insulation Characteristics Curves

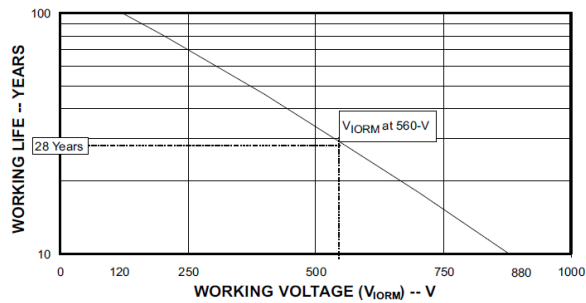

Figure 5-1. Isolation Lifetime Projection

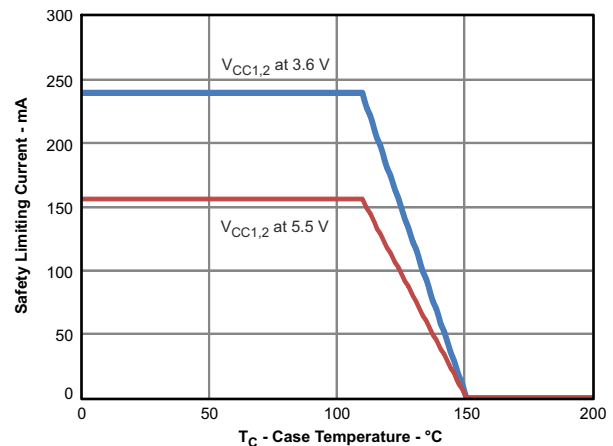

Figure 5-2. Thermal Derating Curve for Limiting Current per VDE

5.22 Typical Characteristics

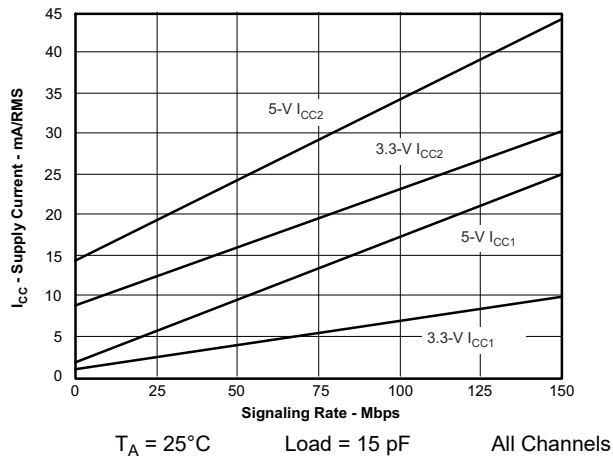

Figure 5-3. ISO7240C/M RMS Supply Current vs Signaling Rate

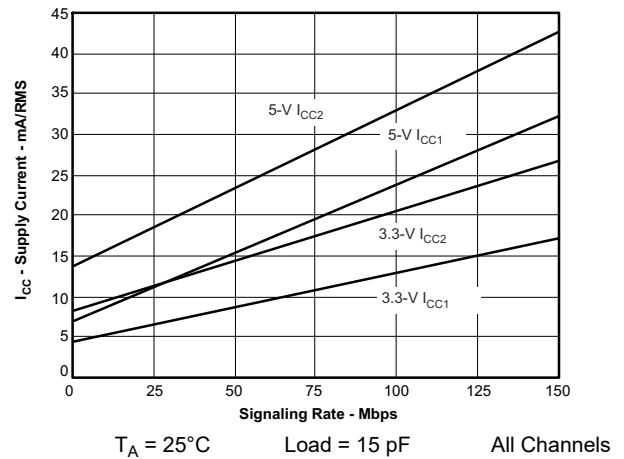

Figure 5-4. ISO7241C/M RMS Supply Current vs Signaling Rate

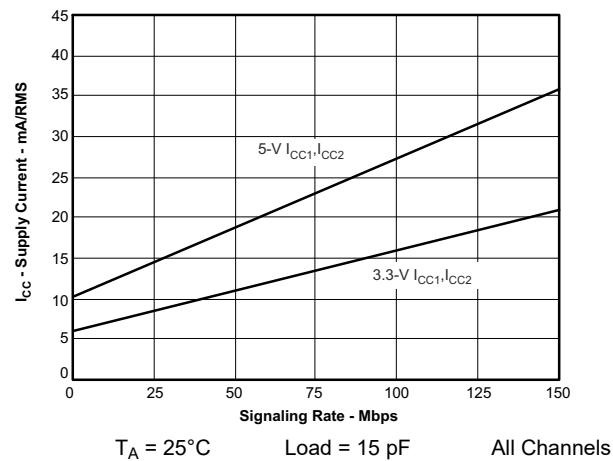

Figure 5-5. ISO7242C/M RMS Supply Current vs Signaling Rate

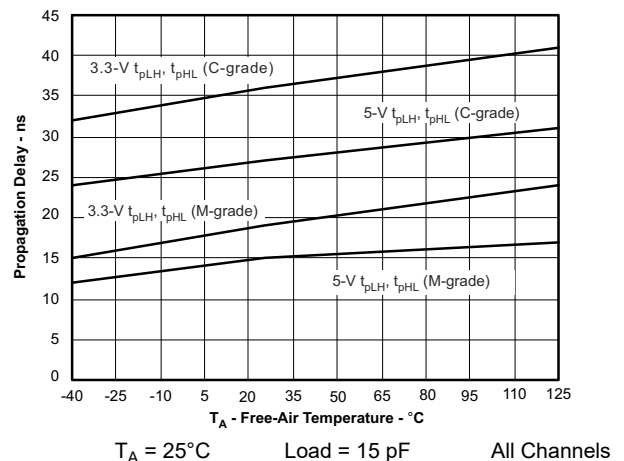

Figure 5-6. Propagation Delay vs Free-Air Temperature

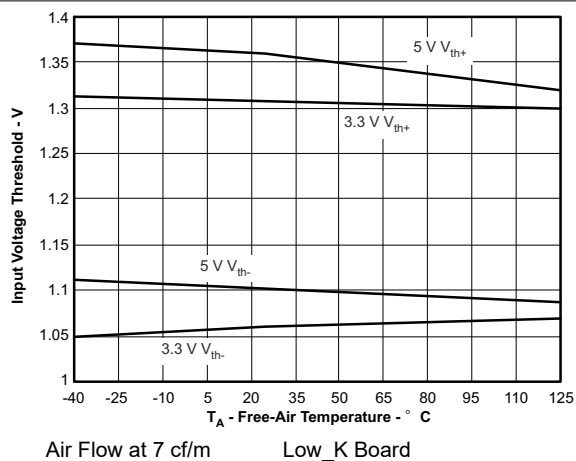

Figure 5-7. Input Voltage Threshold vs Free-Air Temperature

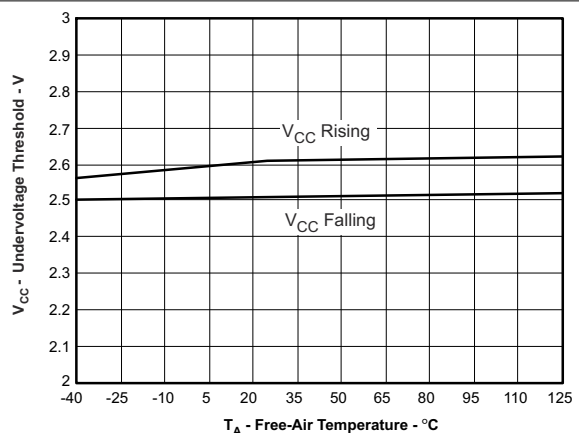

Figure 5-8. V_{CC} Undervoltage Threshold vs Free-Air Temperature

5.22 Typical Characteristics (continued)

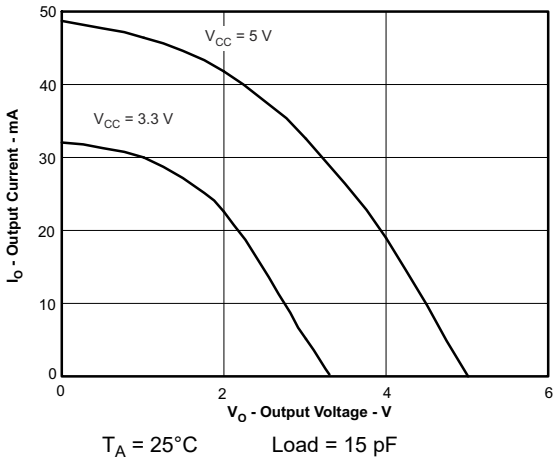

Figure 5-9. High-Level Output Current vs High-Level Output Voltage

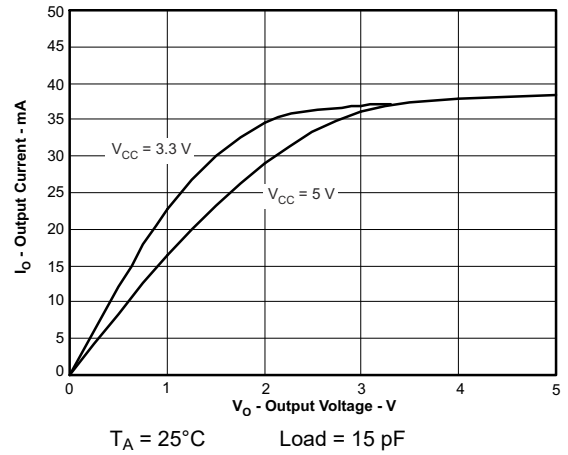
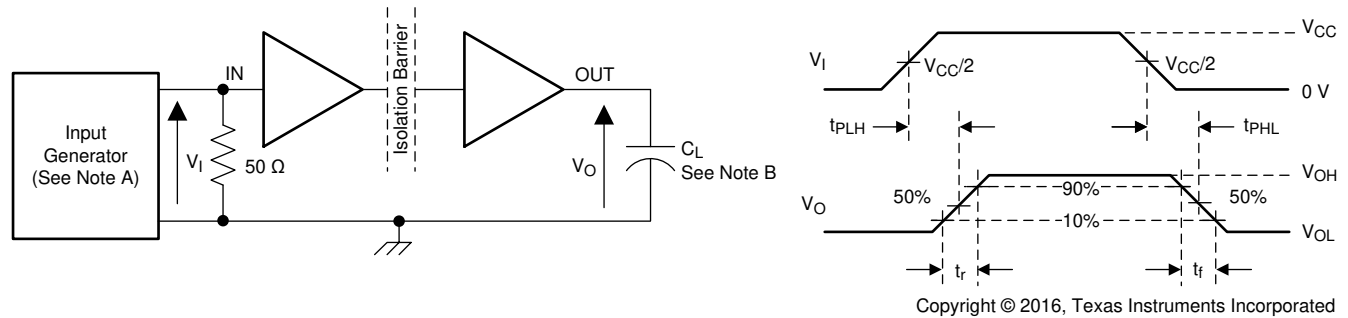

Figure 5-10. Low-Level Output Current vs Low-Level Output Voltage

ISO7240CF, ISO7240C, ISO7240M, ISO7241C, ISO7241M, ISO7242C, ISO7242M

SLLS868W – SEPTEMBER 2007 – REVISED OCTOBER 2025

6 Parameter Measurement Information



- A. The input pulse is supplied by a generator having the following characteristics: PRR \leq 50 kHz, 50% duty cycle, $t_r \leq$ 3 ns, $t_f \leq$ 3 ns, $Z_O = 50 \Omega$.
- B. $C_L = 15$ pF and includes instrumentation and fixture capacitance within $\pm 20\%$.

Figure 6-1. Switching Characteristic Test Circuit and Voltage Waveforms

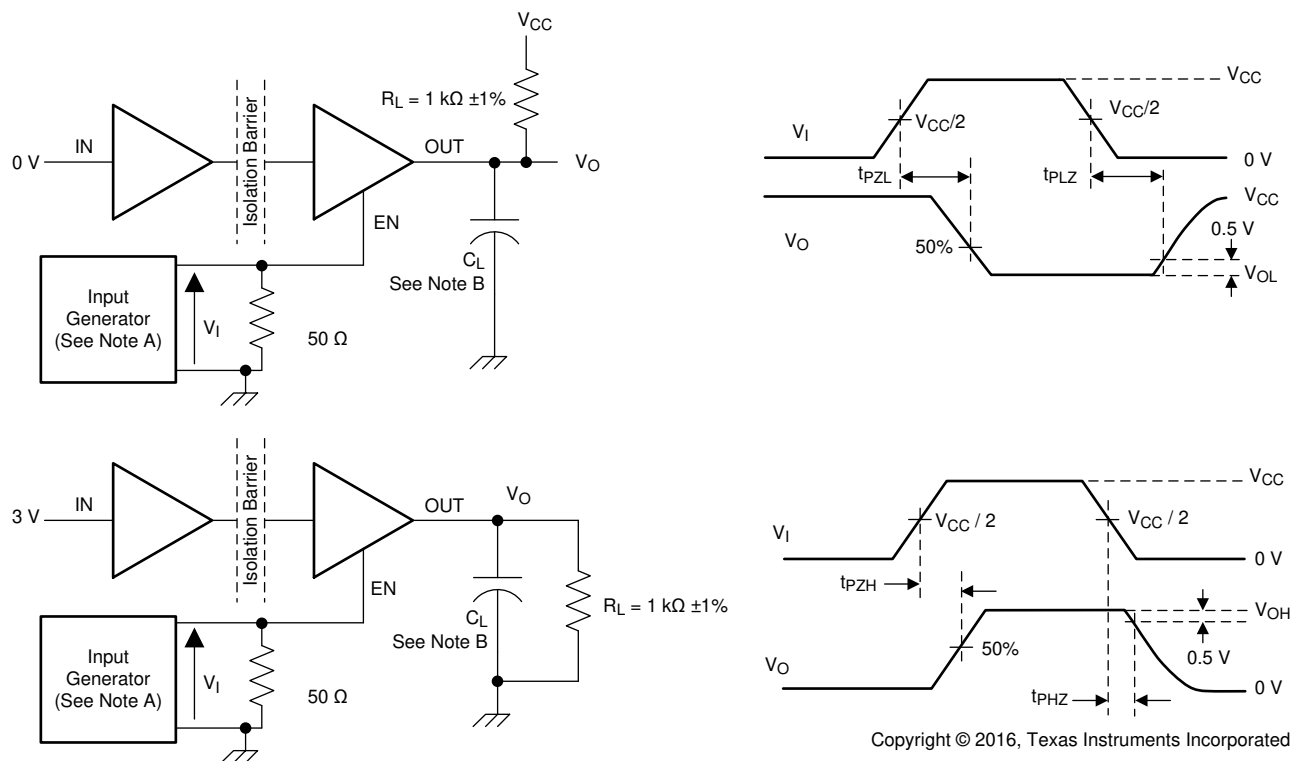

- A. The input pulse is supplied by a generator having the following characteristics: PRR \leq 50 kHz, 50% duty cycle, $t_r \leq$ 3 ns, $t_f \leq$ 3 ns, $Z_O = 50 \Omega$.
- B. $C_L = 15$ pF and includes instrumentation and fixture capacitance within $\pm 20\%$.

Figure 6-2. Enable or Disable Propagation-Delay Time Test Circuit and Waveform

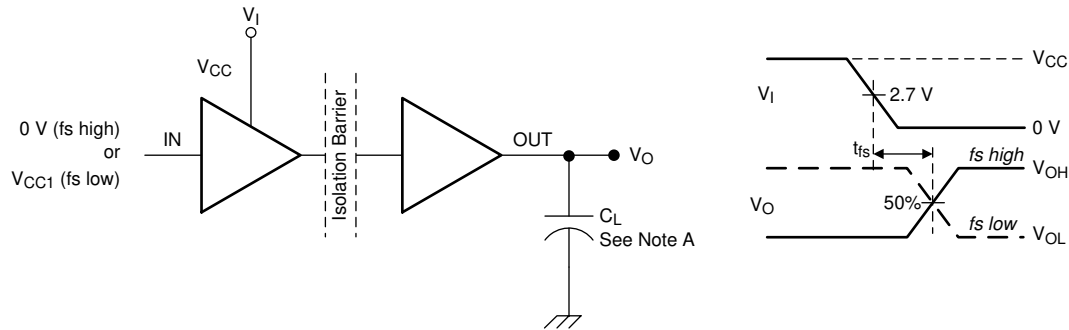

A. $C_L = 15 \text{ pF}$ and includes instrumentation and fixture capacitance within $\pm 20\%$.

Figure 6-3. Failsafe Delay Time Test Circuit and Voltage Waveforms

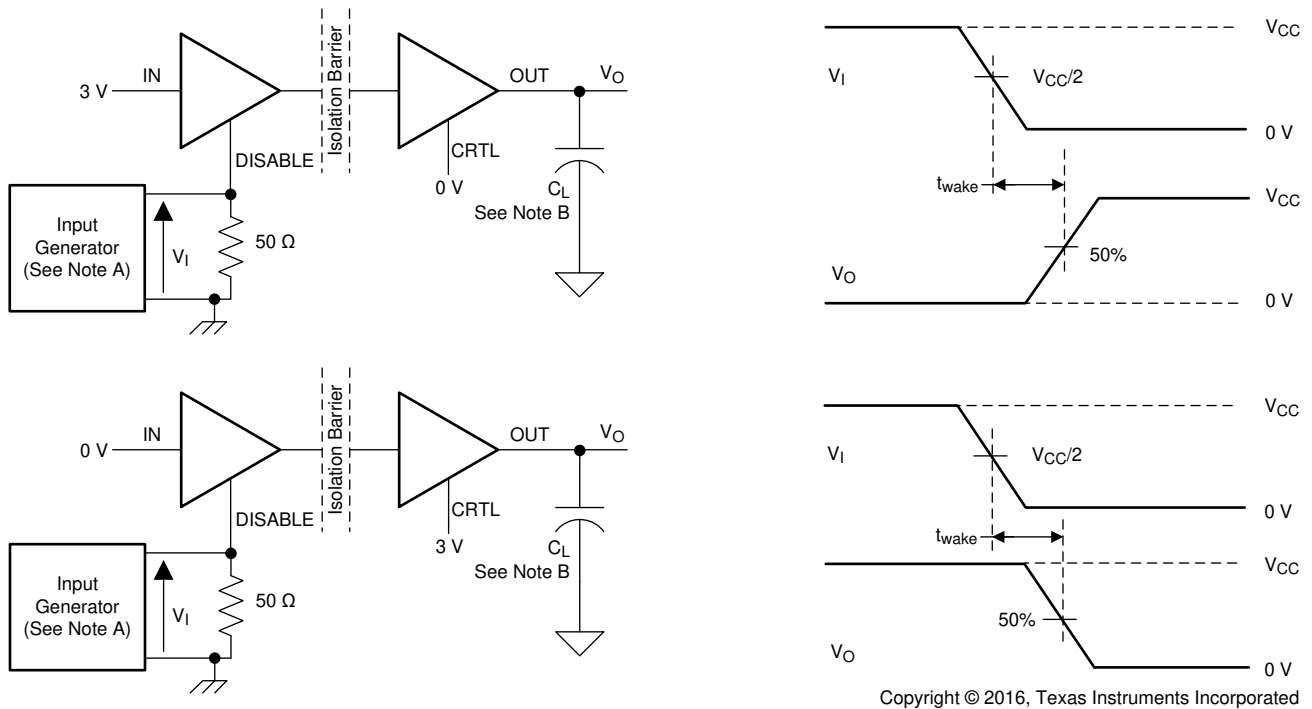

The test that yields the longest time is used in this data sheet.

- A. The input pulse is supplied by a generator having the following characteristics: $\text{PRR} \leq 50 \text{ kHz}$, 50% duty cycle, $t_r \leq 3 \text{ ns}$, $t_f \leq 3 \text{ ns}$, $Z_O = 50 \Omega$.
- B. $C_L = 15 \text{ pF}$ and includes instrumentation and fixture capacitance within $\pm 20\%$.

Figure 6-4. Wake Time From Input Disable Test Circuit and Voltage Waveforms

ISO7240CF, ISO7240C, ISO7240M, ISO7241C, ISO7241M, ISO7242C, ISO7242M
SLLS868W – SEPTEMBER 2007 – REVISED OCTOBER 2025

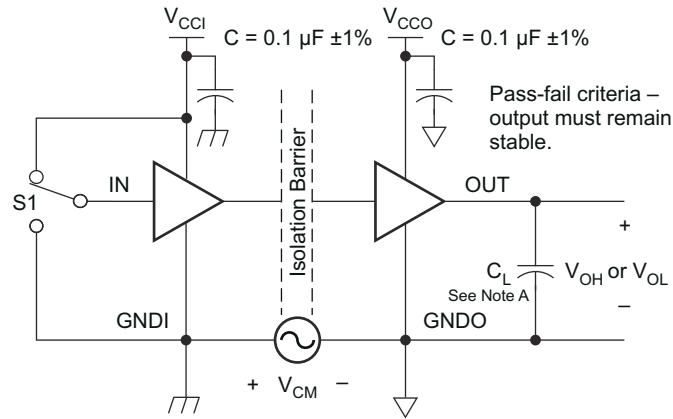

- A. $C_L = 15 \text{ pF}$ and includes instrumentation and fixture capacitance within $\pm 20\%$.
- B. The input pulse is supplied by a generator having the following characteristics: $\text{PRR} \leq 50 \text{ kHz}$, 50% duty cycle, $t_r \leq 3 \text{ ns}$, $t_f \leq 3 \text{ ns}$, $Z_0 = 50 \Omega$.

Figure 6-5. Common-Mode Transient Immunity Test Circuit and Voltage Waveform

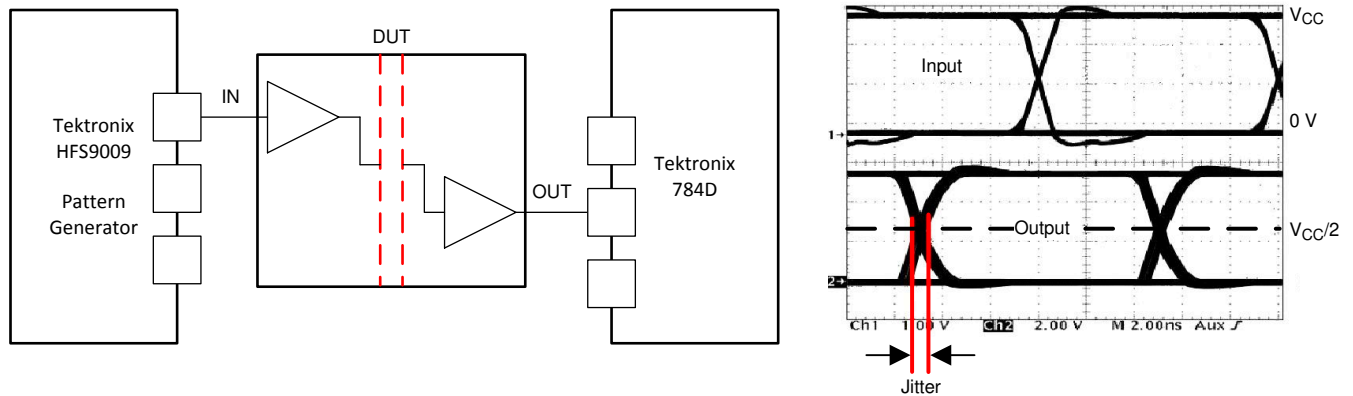

Copyright © 2016, Texas Instruments Incorporated

PRBS bit pattern run length is $2^{16} - 1$. Transition time is 800 ps. NRZ data input has no more than five consecutive 1s or 0s.

Figure 6-6. Peak-to-Peak Eye-Pattern Jitter Test Circuit and Voltage Waveform

7 Detailed Description

7.1 Overview

The ISO724x family of devices transmit digital data across a silicon dioxide based isolation barrier. The digital input signal (IN) of the device is sampled by a transmitter and at every data edge the transmitter sends a corresponding differential signal across the isolation barrier. When the input signal is static, the refresh logic periodically sends the necessary differential signal from the transmitter. On the other side of the isolation barrier, the receiver converts the differential signal into a single-ended signal which is output on the OUT pin through a buffer. If the receiver does not receive a data or refresh signal, the timeout logic detects the loss of signal or power from the input side and drives the output to the default level.

7.2 Functional Block Diagram

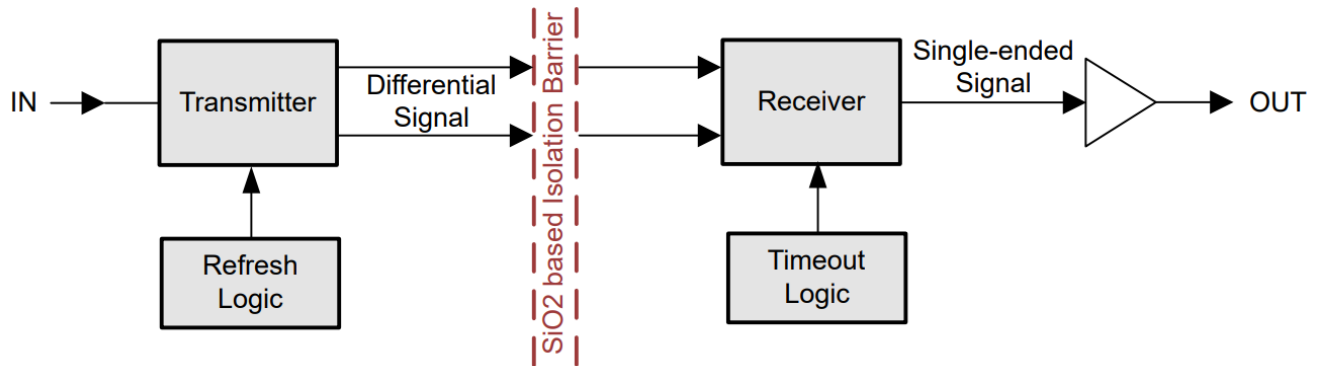

Figure 7-1. Conceptual Block Diagram of a Digital Isolator

ISO7240CF, ISO7240C, ISO7240M, ISO7241C, ISO7241M, ISO7242C, ISO7242M

SLLS868W – SEPTEMBER 2007 – REVISED OCTOBER 2025

7.3 Feature Description

The ISO724x-Q1 family of devices is available in multiple channel configurations and default output-state options to enable wide variety of application uses. [Table 7-1](#) lists these device features.

Table 7-1. Device Features

| PRODUCT ⁽¹⁾ | SIGNALING RATE | INPUT THRESHOLD | CHANNEL CONFIGURATION |
|------------------------|----------------|-----------------|-----------------------|
| ISO7240CF | 25 Mbps | ≈1.5 V (TTL) | 4/0 |
| ISO7241C | 25 Mbps | ≈1.5 V (TTL) | 3/1 |
| ISO7242C | 25 Mbps | ≈1.5 V (TTL) | 2/2 |

7.4 Device Functional Modes

List of ISO7231C-Q1 functional modes.

Table 7-2. Device Function Table ISO7231C-Q1

| INPUT V _{CC} | OUTPUT V _{CC} | INPUT (IN) | OUTPUT ENABLE (EN) | OUTPUT (OUT) |
|-----------------------|------------------------|------------|--------------------|--------------|
| PU | PU | H | H or Open | H |
| | | L | H or Open | L |
| | | X | L | Z |
| | | Open | H or Open | H |
| PD | PU | X | H or Open | H |
| PD | PU | X | L | Z |
| X | PD | X | X | Undetermined |

7.4.1 Device I/O Schematics

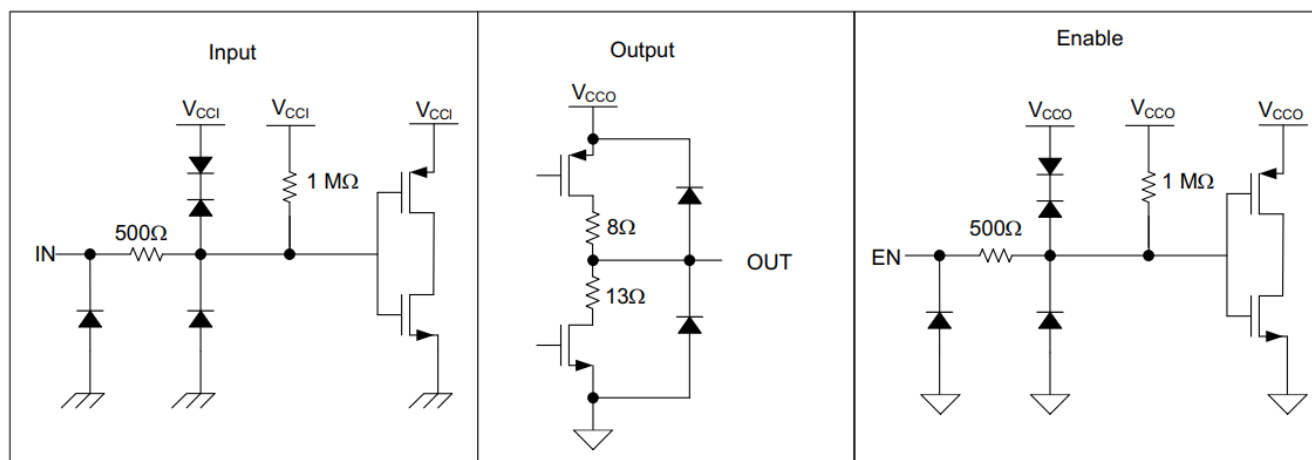
Figure 7-2. Device I/O Schematics

8 Application and Implementation

Note

Information in the following applications sections is not part of the TI component specification, and TI does not warrant its accuracy or completeness. TI's customers are responsible for determining suitability of components for their purposes, as well as validating and testing their design implementation to confirm system functionality.

8.1 Application Information

The ISO724x family of devices uses a single-ended TTL or CMOS-logic switching technology. The supply voltage range is from 3.15 V to 5.5 V for both supplies, V_{CC1} and V_{CC2} . When designing with digital isolators, keep in mind that because of the single-ended design structure, digital isolators do not conform to any specific interface standard and are only intended for isolating single-ended CMOS or TTL digital signal lines. The isolator is typically placed between the data controller (that is, μ C or UART), and a data converter or a line transceiver, regardless of the interface type or standard.

8.2 Typical Application

8.2.1 Isolated Data Acquisition System for Process Control

The ISO724x family of devices can be used with Texas Instruments' precision analog-to-digital converter and mixed signal microcontroller to create an advanced isolated data acquisition system as shown in [Figure 8-1](#).

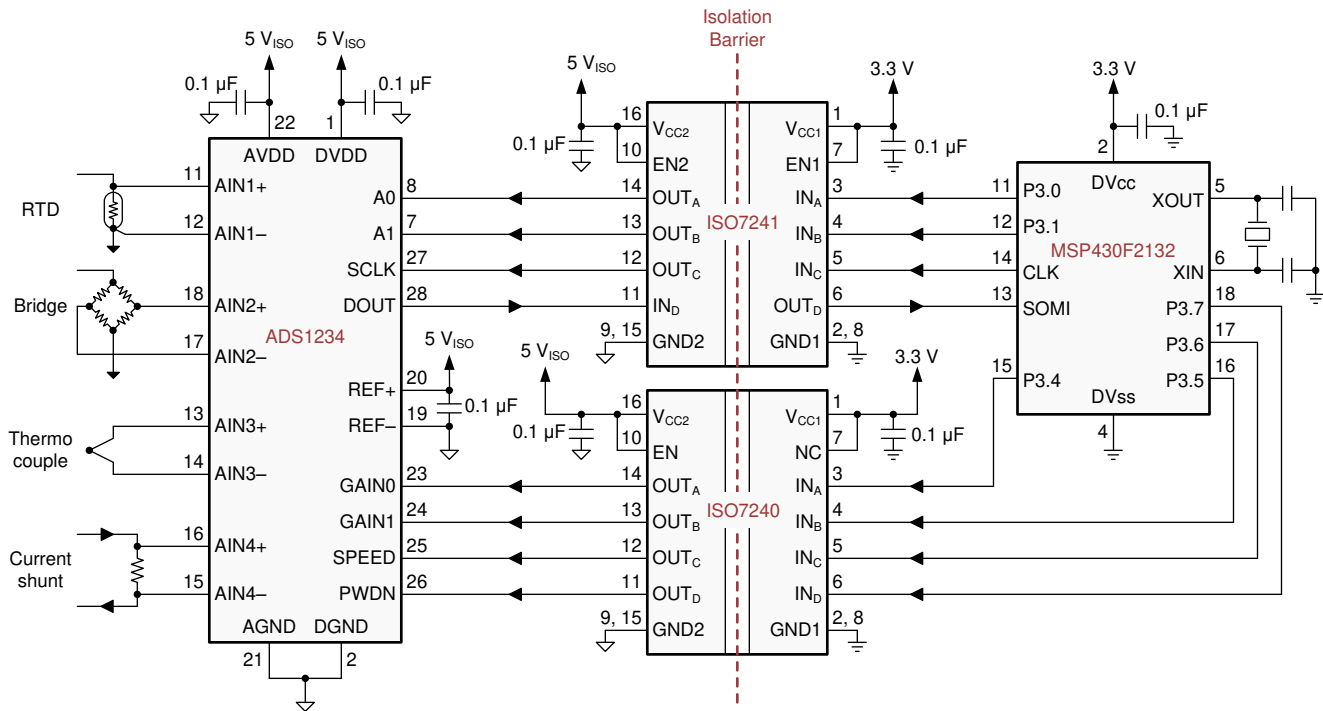

Copyright © 2016, Texas Instruments Incorporated

Figure 8-1. Isolated Data Acquisition System for Process Control

8.2.1.1 Design Requirements

Unlike optocouplers, which require external components to improve performance, provide bias, or limit current, the ISO724x family of devices only require two external bypass capacitors to operate.

ISO7240CF, ISO7240C, ISO7240M, ISO7241C, ISO7241M, ISO7242C, ISO7242M

SLLS868W – SEPTEMBER 2007 – REVISED OCTOBER 2025

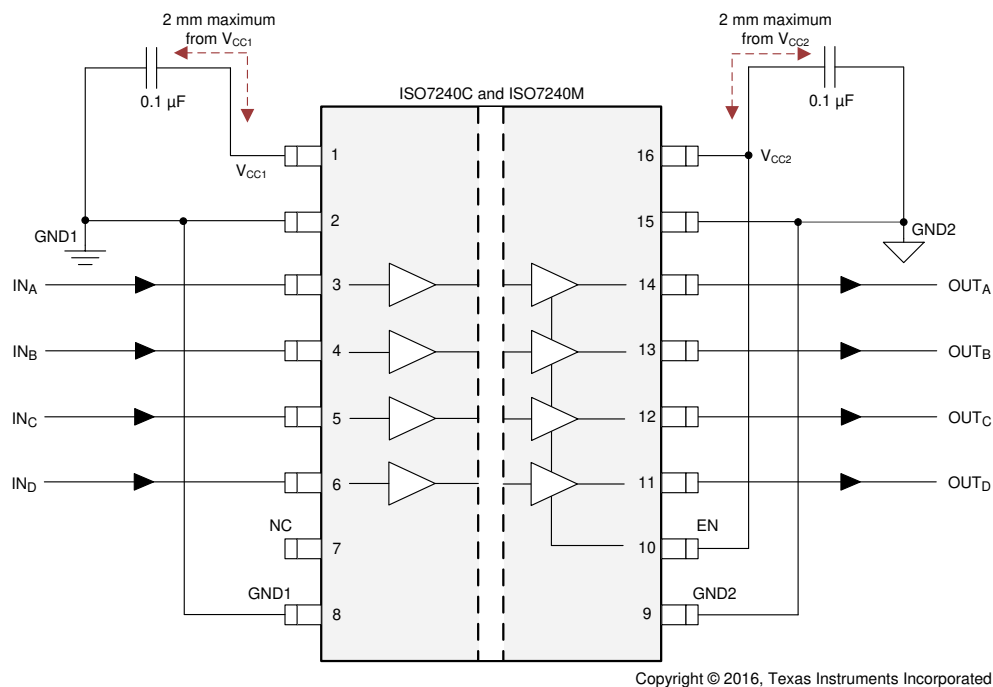
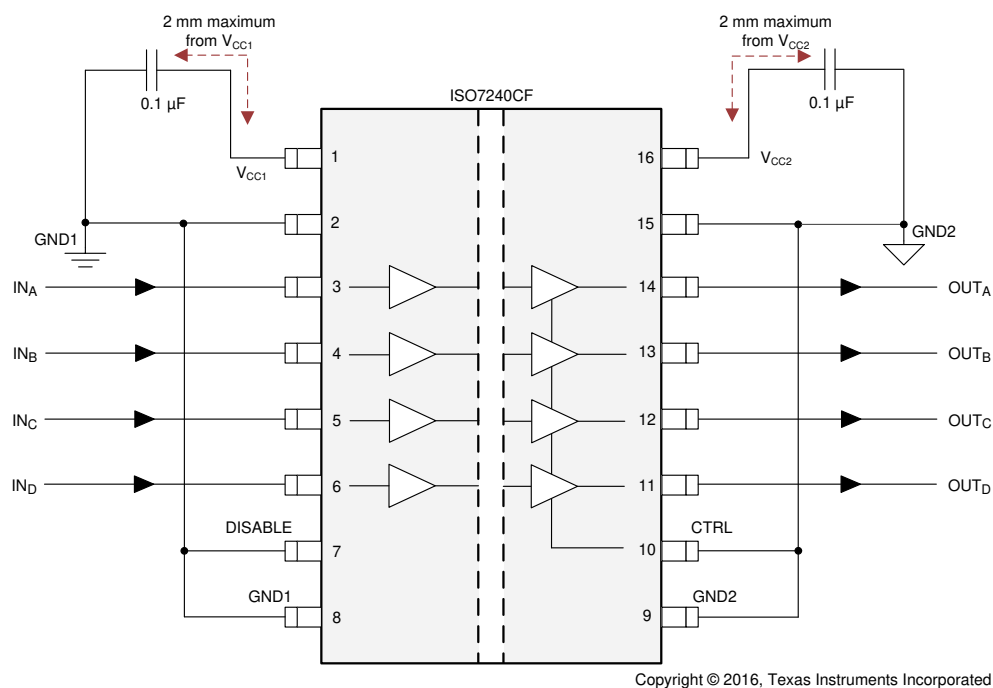
8.2.1.2 Detailed Design Procedure

Figure 8-2. ISO7240x Typical Circuit Hook-Up

Figure 8-3. ISO7240CF Typical Circuit Hook-Up

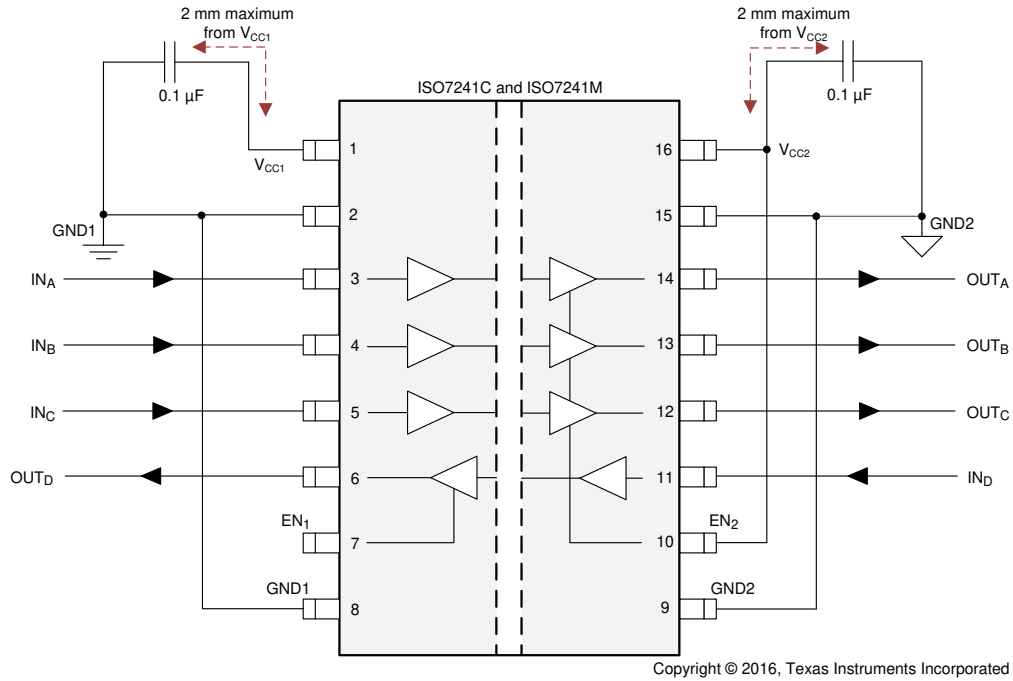

Figure 8-4. ISO7241x Typical Circuit Hook-Up

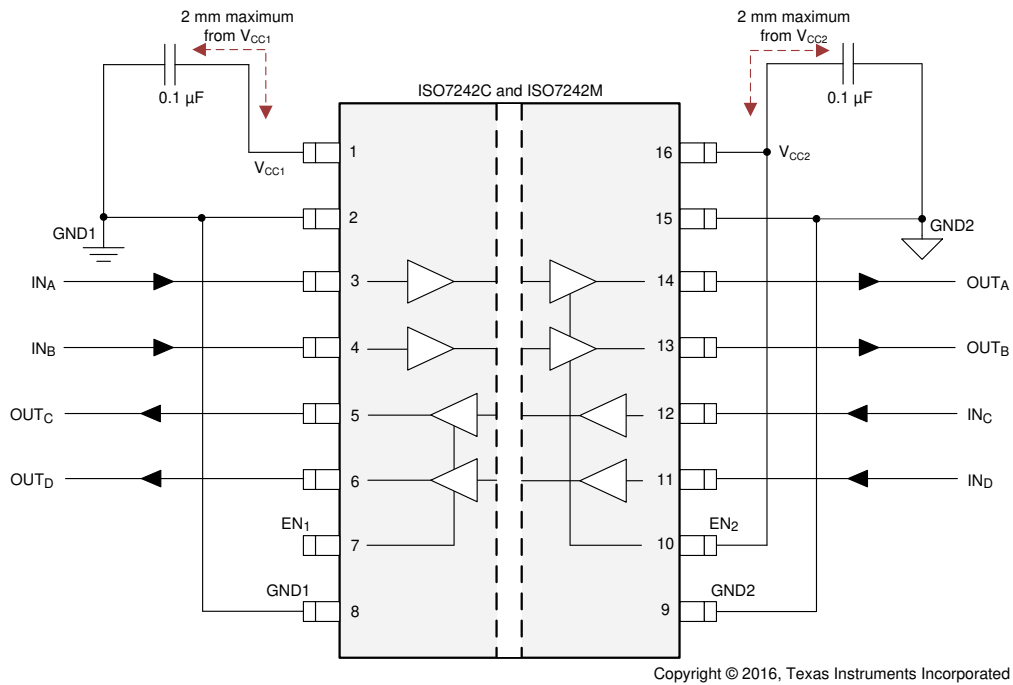
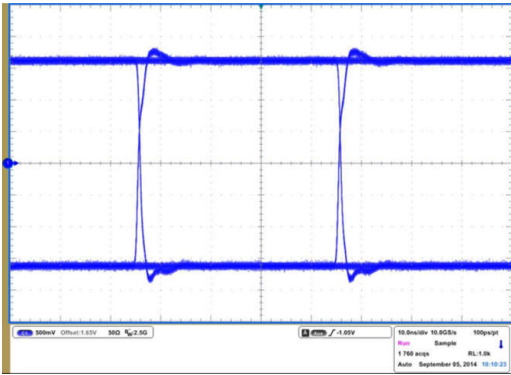
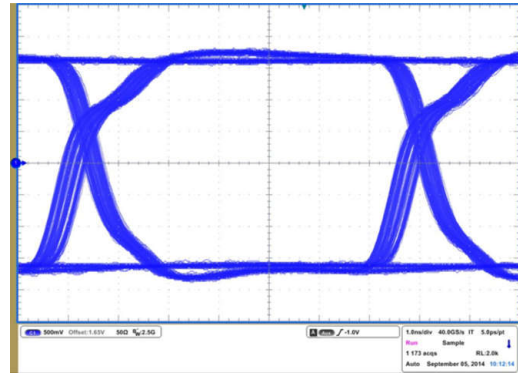

Figure 8-5. ISO7242x Typical Circuit Hook-Up

ISO7240CF, ISO7240C, ISO7240M, ISO7241C, ISO7241M, ISO7242C, ISO7242M

SLLS868W – SEPTEMBER 2007 – REVISED OCTOBER 2025

8.2.1.3 Application Curves

Figure 8-6. ISO7242M Eye Diagram at 25 Mbps, 3.3 V and 25°C

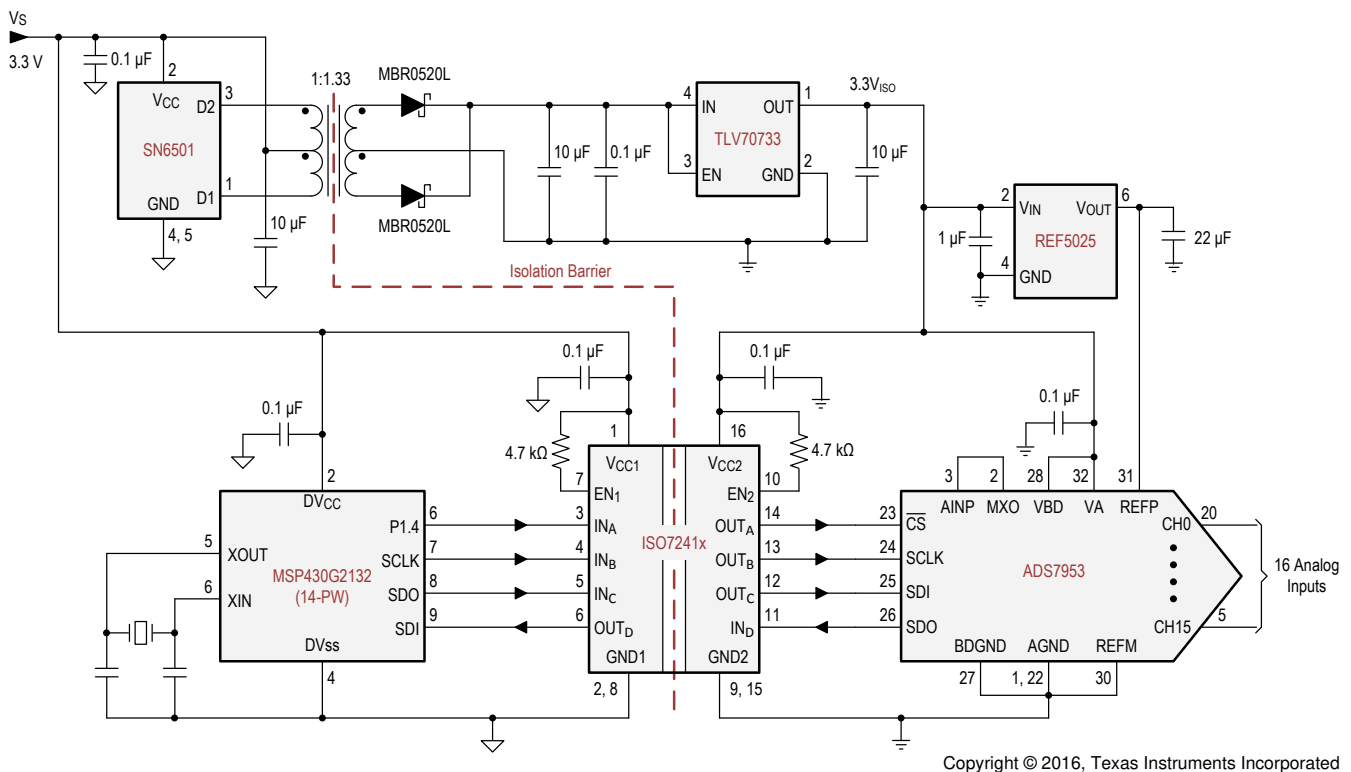
Figure 8-7. ISO7242M Eye Diagram at 150 Mbps, 3.3 V and 25°C
8.2.2 Isolated SPI for an Analog Input Module With 16 Inputs

The ISO7241x family of devices and several other components from Texas Instruments can be used to create an isolated SPI for an input module with 16 inputs.



Copyright © 2016, Texas Instruments Incorporated

Figure 8-8. Isolated SPI for an Analog Input Module With 16 Inputs
8.2.2.1 Design Requirements

See the [Design Requirements](#) in [Section 8.2.1](#).

8.2.2.2 Detailed Design Procedure

See the [Detailed Design Procedure](#) in [Section 8.2.1](#).

8.4 Layout

8.4.1 Layout Guidelines

A minimum of four layers is required to accomplish a low EMI PCB design (see [Figure 8-10](#)). Layer stacking must be in the following order (top-to-bottom): high-speed signal layer, ground plane, power plane and low-frequency signal layer.

- Routing the high-speed traces on the top layer avoids the use of vias (and the introduction of the inductances) and allows for clean interconnects between the isolator and the transmitter and receiver circuits of the data link.
- Placing a solid ground plane next to the high-speed signal layer establishes controlled impedance for transmission line interconnects and provides an excellent low-inductance path for the return current flow.
- Placing the power plane next to the ground plane creates additional high-frequency bypass capacitance of approximately 100 pF/in².
- Routing the slower speed control signals on the bottom layer allows for greater flexibility as these signal links typically have margin to tolerate discontinuities such as vias.

If an additional supply voltage plane or signal layer is needed, add a second power or ground plane system to the stack to keep the planes symmetrical. This makes the stack mechanically stable and prevents warping. Also the power and ground plane of each power system can be placed closer together, thus increasing the high-frequency bypass capacitance significantly.

For detailed layout recommendations, refer to [Digital Isolator Design Guide](#).

8.4.1.1 PCB Material

For digital circuit boards operating at less than 150 Mbps, (or rise and fall times greater than 1 ns), and trace lengths of up to 10 inches, use standard FR-4 UL94V-0 printed circuit board. This PCB is preferred over cheaper alternatives because of lower dielectric losses at high frequencies, less moisture absorption, greater strength and stiffness, and the self-extinguishing flammability-characteristics.

8.4.2 Layout Example

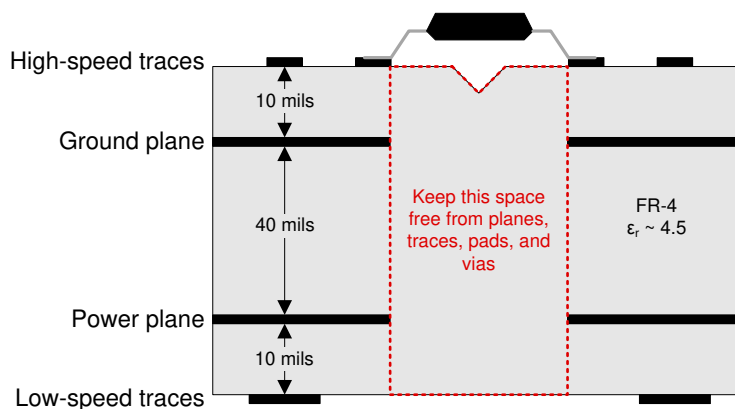

Figure 8-10. Recommended Layer Stack

9 Device and Documentation Support

9.1 Documentation Support

9.1.1 Related Documentation

For related documentation, see the following:

- [Digital Isolator Design Guide](#)
- [Isolation Glossary](#)

9.2 Receiving Notification of Documentation Updates

To receive notification of documentation updates, navigate to the device product folder on [ti.com](#). Click on *Notifications* to register and receive a weekly digest of any product information that has changed. For change details, review the revision history included in any revised document.

9.3 Support Resources

[TI E2E™ support forums](#) are an engineer's go-to source for fast, verified answers and design help — straight from the experts. Search existing answers or ask your own question to get the quick design help you need.

Linked content is provided "AS IS" by the respective contributors. They do not constitute TI specifications and do not necessarily reflect TI's views; see TI's [Terms of Use](#).

9.4 Trademarks

Profibus™ is a trademark of Profibus.

DeviceNet™ is a trademark of Open DeviceNet Vendors Association.

TI E2E™ is a trademark of Texas Instruments.

All trademarks are the property of their respective owners.

9.5 Electrostatic Discharge Caution



This integrated circuit can be damaged by ESD. Texas Instruments recommends that all integrated circuits be handled with appropriate precautions. Failure to observe proper handling and installation procedures can cause damage.

ESD damage can range from subtle performance degradation to complete device failure. Precision integrated circuits may be more susceptible to damage because very small parametric changes could cause the device not to meet its published specifications.

9.6 Glossary

[TI Glossary](#) This glossary lists and explains terms, acronyms, and definitions.

10 Revision History

NOTE: Page numbers for previous revisions may differ from page numbers in the current version.

| Changes from Revision V (February 2025) to Revision W (October 2025) | Page |
|--|-------------|
| • Added fixes for typos and errors in <i>Insulation Specifications</i> table..... | 5 |
| • Changed 'Plan to certify' with 'Certified' in all 3 places in the 2nd row in the <i>Safety-Related Certifications</i> section..... | 5 |
| • Changed 'Certificate planned' with 'Basic certificate: 40047657' in VDE column, 'Master contract number: 220991' in CSA column, and 'File number: E181974' in UL column in the <i>Safety-Related Certifications</i> section..... | 5 |

| Changes from Revision U (October 2024) to Revision V (February 2025) | Page |
|---|-------------|
| • Updated the numbering format for tables, figures, and cross-references throughout the document..... | 1 |

| Changes from Revision T (March 2017) to Revision U (October 2024) | Page |
|--|-------------|
| • Updated reference from capacitive isolation to isolation barrier throughout the document..... | 1 |
| • Updated VDE V 0884-11 to DIN VDE 0884-17 throughout the document..... | 1 |
| • Updated the numbering format for tables, figures, and cross-references throughout the document..... | 1 |
| • Updated Thermal Characteristics, Safety Limiting Values, and Thermal Derating Curves to provide more accurate system-level thermal calculations..... | 6 |
| • Updated electrical and switching characteristics to match device performance..... | 9 |

| Changes from Revision S (April 2016) to Revision T (March 2017) | Page |
|---|-------------|
| • Added isolation resistance for $100^{\circ}\text{C} \leq T_A \leq 125^{\circ}\text{C}$ in the <i>Insulation Specifications</i> table..... | 7 |
| • Deleted the maximum transient overvoltage from VDE in the <i>Safety-Related Certifications</i> table..... | 7 |
| • Added the <i>Receiving Notification of Documentation Updates</i> and the <i>Community Resources</i> section..... | 29 |

11 Mechanical, Packaging, and Orderable Information

The following pages include mechanical, packaging, and orderable information. This information is the most current data available for the designated devices. This data is subject to change without notice and revision of this document. For browser-based versions of this data sheet, refer to the left-hand navigation.

PACKAGING INFORMATION

| Orderable part number | Status (1) | Material type (2) | Package Pins | Package qty Carrier | RoHS (3) | Lead finish/ Ball material (4) | MSL rating/ Peak reflow (5) | Op temp (°C) | Part marking (6) |
|------------------------------|---------------|----------------------|----------------|-----------------------|-------------|--------------------------------------|-----------------------------------|--------------|---------------------|
| ISO7240CDW | Obsolete | Production | SOIC (DW) 16 | - | - | Call TI | Call TI | -40 to 125 | ISO7240C |
| ISO7240CDWR | Active | Production | SOIC (DW) 16 | 2000 LARGE T&R | Yes | NIPDAU | Level-2-260C-1 YEAR | -40 to 125 | ISO7240C |
| ISO7240CDWR.A | Active | Production | SOIC (DW) 16 | 2000 LARGE T&R | Yes | NIPDAU | Level-2-260C-1 YEAR | -40 to 125 | ISO7240C |
| ISO7240CFDW | Obsolete | Production | SOIC (DW) 16 | - | - | Call TI | Call TI | -40 to 125 | ISO7240CF |
| ISO7240CFDWR | Active | Production | SOIC (DW) 16 | 2000 LARGE T&R | Yes | NIPDAU | Level-2-260C-1 YEAR | -40 to 125 | ISO7240CF |
| ISO7240CFDWR.A | Active | Production | SOIC (DW) 16 | 2000 LARGE T&R | Yes | NIPDAU | Level-2-260C-1 YEAR | -40 to 125 | ISO7240CF |
| ISO7240MDW | Obsolete | Production | SOIC (DW) 16 | - | - | Call TI | Call TI | -40 to 125 | ISO7240M |
| ISO7240MDWR | Active | Production | SOIC (DW) 16 | 2000 LARGE T&R | Yes | NIPDAU | Level-2-260C-1 YEAR | -40 to 125 | ISO7240M |
| ISO7240MDWR.A | Active | Production | SOIC (DW) 16 | 2000 LARGE T&R | Yes | NIPDAU | Level-2-260C-1 YEAR | -40 to 125 | ISO7240M |
| ISO7240MDWRG4 | Active | Production | SOIC (DW) 16 | 2000 LARGE T&R | Yes | NIPDAU | Level-2-260C-1 YEAR | -40 to 125 | ISO7240M |
| ISO7241CDW | Obsolete | Production | SOIC (DW) 16 | - | - | Call TI | Call TI | -40 to 125 | ISO7241C |
| ISO7241CDWR | Active | Production | SOIC (DW) 16 | 2000 LARGE T&R | Yes | NIPDAU | Level-2-260C-1 YEAR | -40 to 125 | ISO7241C |
| ISO7241CDWR.A | Active | Production | SOIC (DW) 16 | 2000 LARGE T&R | Yes | NIPDAU | Level-2-260C-1 YEAR | -40 to 125 | ISO7241C |
| ISO7241CDWRG4 | Active | Production | SOIC (DW) 16 | 2000 LARGE T&R | Yes | NIPDAU | Level-2-260C-1 YEAR | -40 to 125 | ISO7241C |
| ISO7241MDW | Obsolete | Production | SOIC (DW) 16 | - | - | Call TI | Call TI | -40 to 125 | ISO7241M |
| ISO7241MDWR | Active | Production | SOIC (DW) 16 | 2000 LARGE T&R | Yes | NIPDAU | Level-2-260C-1 YEAR | -40 to 125 | ISO7241M |
| ISO7241MDWR.A | Active | Production | SOIC (DW) 16 | 2000 LARGE T&R | Yes | NIPDAU | Level-2-260C-1 YEAR | -40 to 125 | ISO7241M |
| ISO7241MDWRG4 | Active | Production | SOIC (DW) 16 | 2000 LARGE T&R | Yes | NIPDAU | Level-2-260C-1 YEAR | -40 to 125 | ISO7241M |
| ISO7242CDW | Obsolete | Production | SOIC (DW) 16 | - | - | Call TI | Call TI | -40 to 125 | ISO7242C |
| ISO7242CDWR | Active | Production | SOIC (DW) 16 | 2000 LARGE T&R | Yes | NIPDAU | Level-2-260C-1 YEAR | -40 to 125 | ISO7242C |
| ISO7242CDWR.A | Active | Production | SOIC (DW) 16 | 2000 LARGE T&R | Yes | NIPDAU | Level-2-260C-1 YEAR | -40 to 125 | ISO7242C |
| ISO7242MDW | Obsolete | Production | SOIC (DW) 16 | - | - | Call TI | Call TI | -40 to 125 | ISO7242M |
| ISO7242MDWR | Active | Production | SOIC (DW) 16 | 2000 LARGE T&R | Yes | NIPDAU | Level-2-260C-1 YEAR | -40 to 125 | ISO7242M |
| ISO7242MDWR.A | Active | Production | SOIC (DW) 16 | 2000 LARGE T&R | Yes | NIPDAU | Level-2-260C-1 YEAR | -40 to 125 | ISO7242M |
| ISO7242MDWRG4 | Active | Production | SOIC (DW) 16 | 2000 LARGE T&R | Yes | NIPDAU | Level-2-260C-1 YEAR | -40 to 125 | ISO7242M |

⁽¹⁾ **Status:** For more details on status, see our [product life cycle](#).

- (2) **Material type:** When designated, preproduction parts are prototypes/experimental devices, and are not yet approved or released for full production. Testing and final process, including without limitation quality assurance, reliability performance testing, and/or process qualification, may not yet be complete, and this item is subject to further changes or possible discontinuation. If available for ordering, purchases will be subject to an additional waiver at checkout, and are intended for early internal evaluation purposes only. These items are sold without warranties of any kind.
- (3) **RoHS values:** Yes, No, RoHS Exempt. See the [TI RoHS Statement](#) for additional information and value definition.
- (4) **Lead finish/Ball material:** Parts may have multiple material finish options. Finish options are separated by a vertical ruled line. Lead finish/Ball material values may wrap to two lines if the finish value exceeds the maximum column width.
- (5) **MSL rating/Peak reflow:** The moisture sensitivity level ratings and peak solder (reflow) temperatures. In the event that a part has multiple moisture sensitivity ratings, only the lowest level per JEDEC standards is shown. Refer to the shipping label for the actual reflow temperature that will be used to mount the part to the printed circuit board.
- (6) **Part marking:** There may be an additional marking, which relates to the logo, the lot trace code information, or the environmental category of the part.

Multiple part markings will be inside parentheses. Only one part marking contained in parentheses and separated by a "~" will appear on a part. If a line is indented then it is a continuation of the previous line and the two combined represent the entire part marking for that device.

Important Information and Disclaimer: The information provided on this page represents TI's knowledge and belief as of the date that it is provided. TI bases its knowledge and belief on information provided by third parties, and makes no representation or warranty as to the accuracy of such information. Efforts are underway to better integrate information from third parties. TI has taken and continues to take reasonable steps to provide representative and accurate information but may not have conducted destructive testing or chemical analysis on incoming materials and chemicals. TI and TI suppliers consider certain information to be proprietary, and thus CAS numbers and other limited information may not be available for release.

In no event shall TI's liability arising out of such information exceed the total purchase price of the TI part(s) at issue in this document sold by TI to Customer on an annual basis.

OTHER QUALIFIED VERSIONS OF ISO7240CF, ISO7241C, ISO7242C :

- Automotive : [ISO7240CF-Q1](#), [ISO7241C-Q1](#), [ISO7242C-Q1](#)

NOTE: Qualified Version Definitions:

- Automotive - Q100 devices qualified for high-reliability automotive applications targeting zero defects

TAPE AND REEL INFORMATION

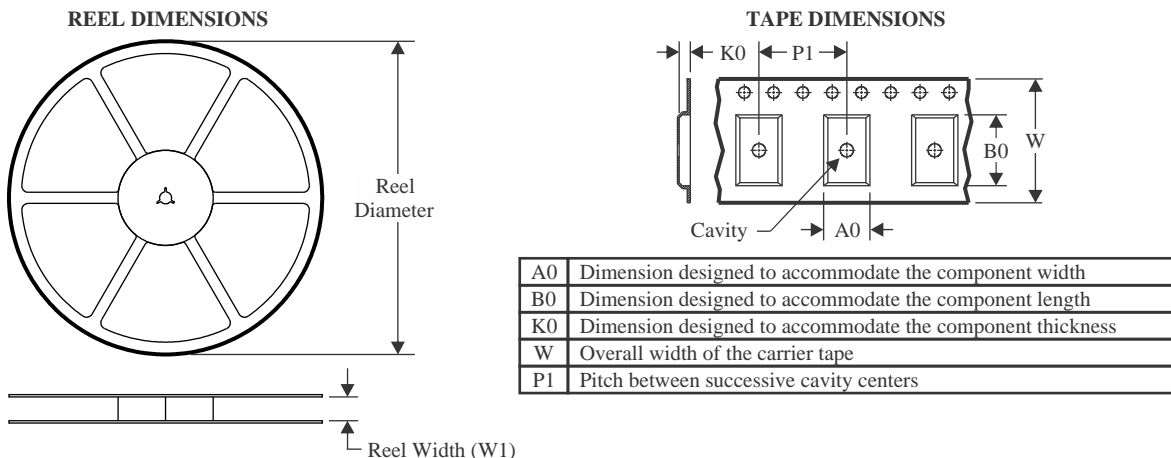

QUADRANT ASSIGNMENTS FOR PIN 1 ORIENTATION IN TAPE

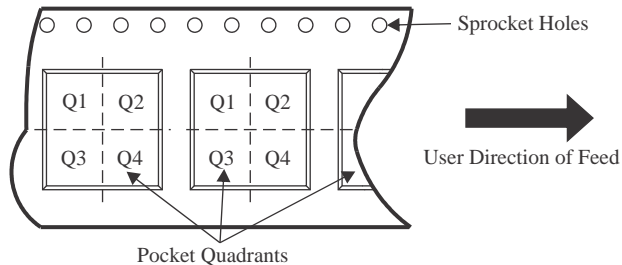

*All dimensions are nominal

| Device | Package Type | Package Drawing | Pins | SPQ | Reel Diameter (mm) | Reel Width W1 (mm) | A0 (mm) | B0 (mm) | K0 (mm) | P1 (mm) | W (mm) | Pin1 Quadrant |
|--------------|--------------|-----------------|------|------|--------------------|--------------------|---------|---------|---------|---------|--------|---------------|
| ISO7240CDWR | SOIC | DW | 16 | 2000 | 330.0 | 16.4 | 10.75 | 10.7 | 2.7 | 12.0 | 16.0 | Q1 |
| ISO7240CFDWR | SOIC | DW | 16 | 2000 | 330.0 | 16.4 | 10.75 | 10.7 | 2.7 | 12.0 | 16.0 | Q1 |
| ISO7240MDWR | SOIC | DW | 16 | 2000 | 330.0 | 16.4 | 10.75 | 10.7 | 2.7 | 12.0 | 16.0 | Q1 |
| ISO7241CDWR | SOIC | DW | 16 | 2000 | 330.0 | 16.4 | 10.75 | 10.7 | 2.7 | 12.0 | 16.0 | Q1 |
| ISO7241MDWR | SOIC | DW | 16 | 2000 | 330.0 | 16.4 | 10.75 | 10.7 | 2.7 | 12.0 | 16.0 | Q1 |
| ISO7242CDWR | SOIC | DW | 16 | 2000 | 330.0 | 16.4 | 10.75 | 10.7 | 2.7 | 12.0 | 16.0 | Q1 |
| ISO7242MDWR | SOIC | DW | 16 | 2000 | 330.0 | 16.4 | 10.75 | 10.7 | 2.7 | 12.0 | 16.0 | Q1 |

TAPE AND REEL BOX DIMENSIONS

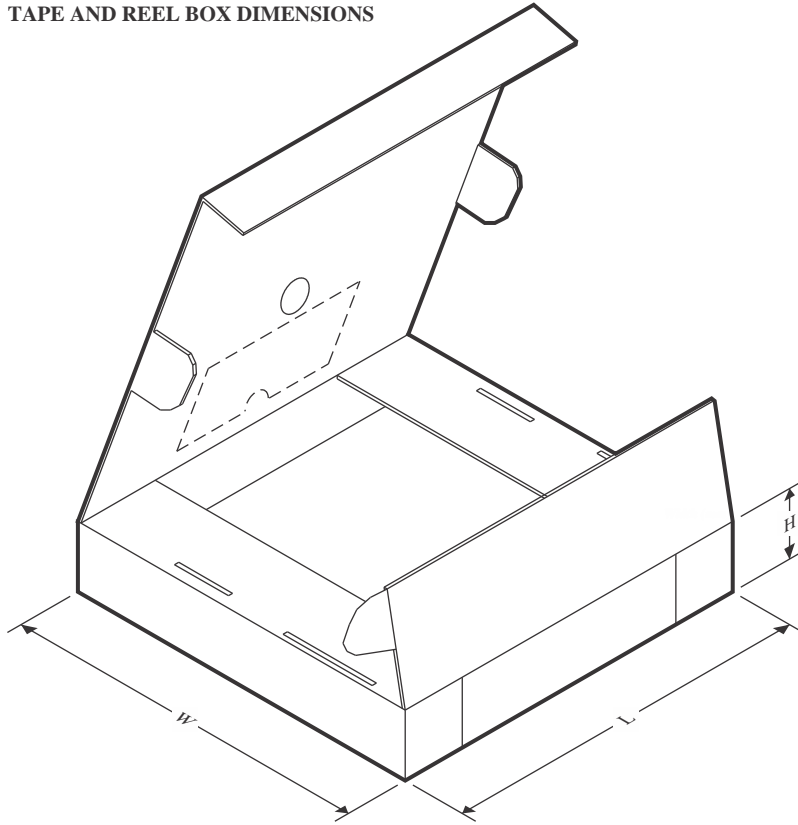

*All dimensions are nominal

| Device | Package Type | Package Drawing | Pins | SPQ | Length (mm) | Width (mm) | Height (mm) |
|--------------|--------------|-----------------|------|------|-------------|------------|-------------|
| ISO7240CDWR | SOIC | DW | 16 | 2000 | 350.0 | 350.0 | 43.0 |
| ISO7240CFDWR | SOIC | DW | 16 | 2000 | 350.0 | 350.0 | 43.0 |
| ISO7240MDWR | SOIC | DW | 16 | 2000 | 350.0 | 350.0 | 43.0 |
| ISO7241CDWR | SOIC | DW | 16 | 2000 | 350.0 | 350.0 | 43.0 |
| ISO7241MDWR | SOIC | DW | 16 | 2000 | 350.0 | 350.0 | 43.0 |
| ISO7242CDWR | SOIC | DW | 16 | 2000 | 350.0 | 350.0 | 43.0 |
| ISO7242MDWR | SOIC | DW | 16 | 2000 | 350.0 | 350.0 | 43.0 |

GENERIC PACKAGE VIEW

DW 16

SOIC - 2.65 mm max height

7.5 x 10.3, 1.27 mm pitch

SMALL OUTLINE INTEGRATED CIRCUIT

This image is a representation of the package family, actual package may vary.
Refer to the product data sheet for package details.

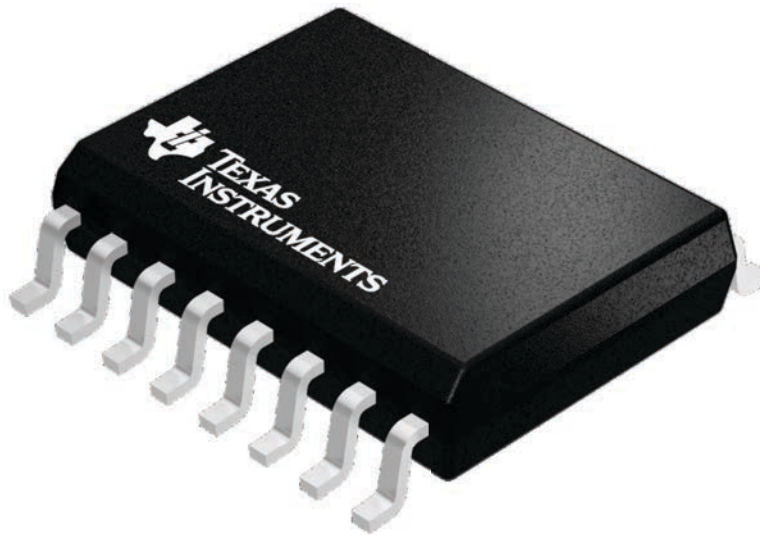

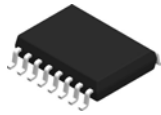

DW0016B

PACKAGE OUTLINE

SOIC - 2.65 mm max height

SOIC

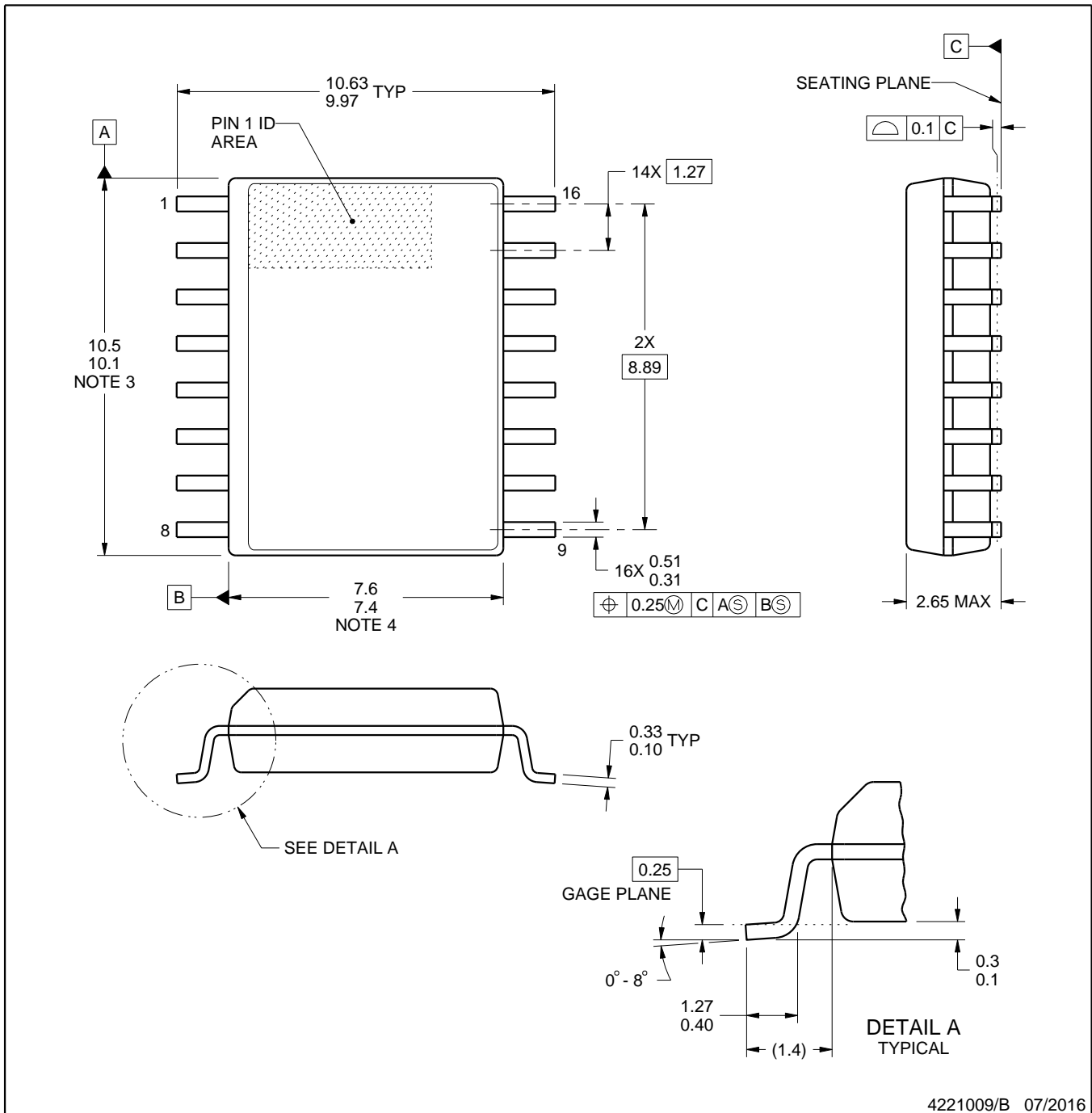

NOTES:

- All linear dimensions are in millimeters. Dimensions in parenthesis are for reference only. Dimensioning and tolerancing per ASME Y14.5M.
- This drawing is subject to change without notice.
- This dimension does not include mold flash, protrusions, or gate burrs. Mold flash, protrusions, or gate burrs shall not exceed 0.15 mm, per side.
- This dimension does not include interlead flash. Interlead flash shall not exceed 0.25 mm, per side.
- Reference JEDEC registration MS-013.

EXAMPLE BOARD LAYOUT

DW0016B

SOIC - 2.65 mm max height

SOIC

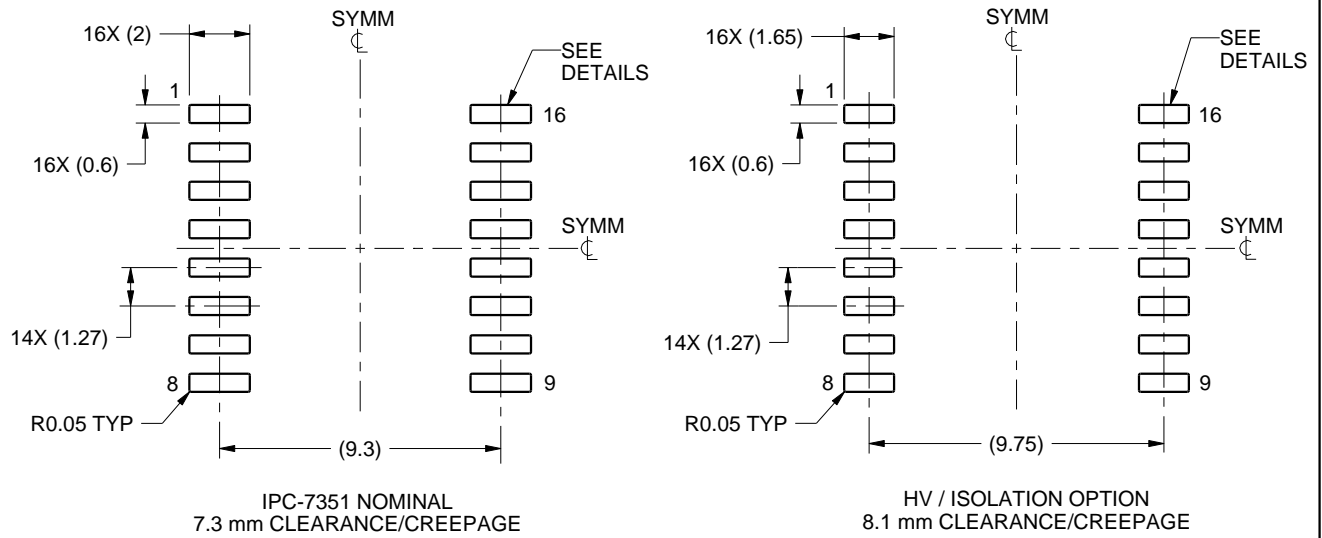

LAND PATTERN EXAMPLE
SCALE:4X

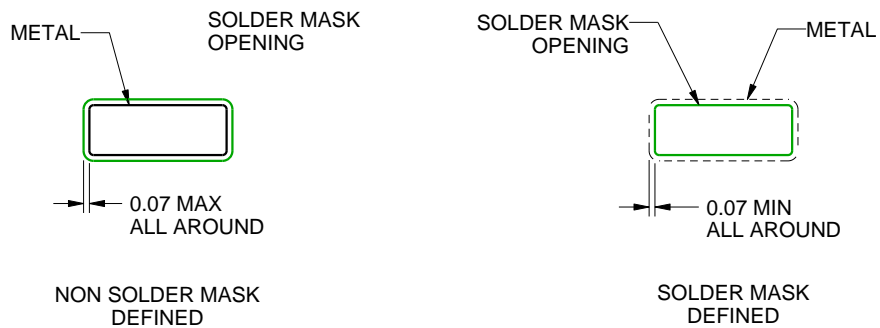

SOLDER MASK DETAILS

4221009/B 07/2016

NOTES: (continued)

- 6. Publication IPC-7351 may have alternate designs.
- 7. Solder mask tolerances between and around signal pads can vary based on board fabrication site.

EXAMPLE STENCIL DESIGN

DW0016B

SOIC - 2.65 mm max height

SOIC

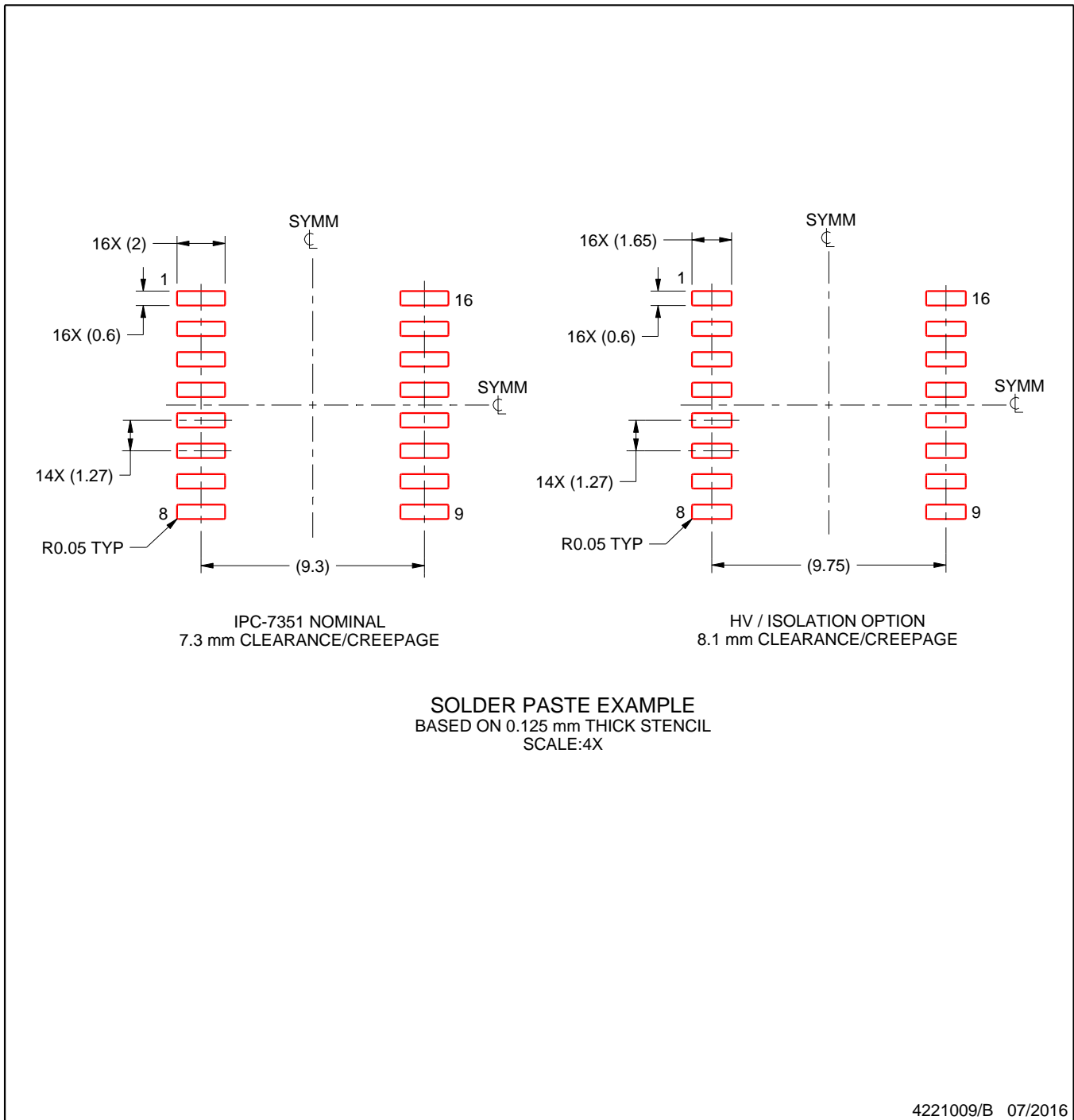

NOTES: (continued)

- 8. Laser cutting apertures with trapezoidal walls and rounded corners may offer better paste release. IPC-7525 may have alternate design recommendations.
- 9. Board assembly site may have different recommendations for stencil design.

IMPORTANT NOTICE AND DISCLAIMER

TI PROVIDES TECHNICAL AND RELIABILITY DATA (INCLUDING DATASHEETS), DESIGN RESOURCES (INCLUDING REFERENCE DESIGNS), APPLICATION OR OTHER DESIGN ADVICE, WEB TOOLS, SAFETY INFORMATION, AND OTHER RESOURCES "AS IS" AND WITH ALL FAULTS, AND DISCLAIMS ALL WARRANTIES, EXPRESS AND IMPLIED, INCLUDING WITHOUT LIMITATION ANY IMPLIED WARRANTIES OF MERCHANTABILITY, FITNESS FOR A PARTICULAR PURPOSE OR NON-INFRINGEMENT OF THIRD PARTY INTELLECTUAL PROPERTY RIGHTS.

These resources are intended for skilled developers designing with TI products. You are solely responsible for (1) selecting the appropriate TI products for your application, (2) designing, validating and testing your application, and (3) ensuring your application meets applicable standards, and any other safety, security, regulatory or other requirements.

These resources are subject to change without notice. TI grants you permission to use these resources only for development of an application that uses the TI products described in the resource. Other reproduction and display of these resources is prohibited. No license is granted to any other TI intellectual property right or to any third party intellectual property right. TI disclaims responsibility for, and you fully indemnify TI and its representatives against any claims, damages, costs, losses, and liabilities arising out of your use of these resources.

TI's products are provided subject to [TI's Terms of Sale](#), [TI's General Quality Guidelines](#), or other applicable terms available either on ti.com or provided in conjunction with such TI products. TI's provision of these resources does not expand or otherwise alter TI's applicable warranties or warranty disclaimers for TI products. Unless TI explicitly designates a product as custom or customer-specified, TI products are standard, catalog, general purpose devices.

TI objects to and rejects any additional or different terms you may propose.

Copyright © 2026, Texas Instruments Incorporated

Last updated 10/2025

OUR CERTIFICATE

DiGi provide top-quality products and perfect service for customer worldwide through standardization, technological innovation and continuous improvement. DiGi through third-party certification, we stricly control the quality of products and services. Welcome your RFQ to

Email: Info@DiGi-Electronics.com



Tel: +00 852-30501935

RFQ Email: Info@DiGi-Electronics.com

DiGi is a global authorized distributor of electronic components.