

LM2592HVT-ADJ Datasheet

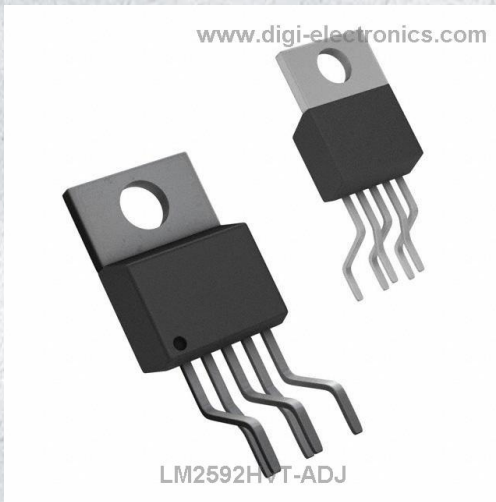

<https://www.DiGi-Electronics.com>

DiGi Electronics Part Number	LM2592HVT-ADJ-DG
Manufacturer	Texas Instruments
Manufacturer Product Number	LM2592HVT-ADJ
Description	IC REG BUCK ADJ 2A TO220-5
Detailed Description	Buck Switching Regulator IC Positive Adjustable 1.2 V 1 Output 2A TO-220-5 Formed Leads



Tel: +00 852-30501935

RFQ Email: Info@DiGi-Electronics.com

DiGi is a global authorized distributor of electronic components.

Purchase and inquiry

Manufacturer Product Number:

LM2592HVT-ADJ

Series:

SIMPLE SWITCHER®

Function:

Step-Down

Topology:

Buck

Number of Outputs:

1

Voltage - Input (Max):

60V

Voltage - Output (Max):

57V

Frequency - Switching:

150kHz

Operating Temperature:

-40°C ~ 125°C (TJ)

Package / Case:

TO-220-5 Formed Leads

Base Product Number:

LM2592

Manufacturer:

Texas Instruments

Product Status:

Last Time Buy

Output Configuration:

Positive

Output Type:

Adjustable

Voltage - Input (Min):

4.5V

Voltage - Output (Min/Fixed):

1.2V

Current - Output:

2A

Synchronous Rectifier:

No

Mounting Type:

Through Hole

Supplier Device Package:

TO-220-5

Environmental & Export classification

RoHS Status:

ROHS3 Compliant

REACH Status:

REACH Unaffected

HTSUS:

8542.39.0001

Moisture Sensitivity Level (MSL):

1 (Unlimited)

ECCN:

EAR99

LM2592HV SIMPLE SWITCHER® Power Converter 150-kHz 2-A Step-Down Voltage Regulator

1 Features

- 3.3-V, 5-V, and Adjustable Output Versions
- Adjustable Version Output Voltage Range: 1.2 V to 57 V $\pm 4\%$ Maximum Over Line and Load Conditions
- 2-A Output Load Current
- Available in 5-Pin Package
- Input Voltage Range up to 60V
- 150-kHz Fixed Frequency Internal Oscillator
- ON and OFF Control
- Low Power Standby Mode, I_Q Typically 90 μ A
- High Efficiency
- Thermal Shutdown and Current-Limit Protection

2 Applications

- Simple High-Efficiency Step-Down (Buck) Regulators
- Efficient Preregulator for Linear Regulators
- On-Card Switching Regulators
- Positive-to-Negative Converters

3 Description

The LM2592HV series of regulators are monolithic integrated circuits that provide all the active functions for a step-down (buck) switching regulator, capable of driving a 2-A load with excellent line and load regulation. These devices are available in fixed output voltages of 3.3 V, 5 V, and an adjustable output version.

This series of switching regulators is similar to the LM2593HV, but without some of the supervisory and control features of the latter.

Requiring a minimum number of external components, these regulators are simple to use and include internal frequency compensation, improved line and load specifications, and a fixed-frequency oscillator.

The LM2592HV operates at a switching frequency of 150 kHz, thus allowing smaller sized filter components than what would be needed with lower frequency switching regulators. Available in a standard 5-pin package with several different lead bend options, and a 5-pin surface mount package.

Device Information⁽¹⁾

PART NUMBER	PACKAGE	BODY SIZE (NOM)
LM2591HV	DDPAK/TO-263 (5)	10.18 mm x 8.41 mm
	TO-220 (5)	14.986 mm x 10.16 mm

(1) For all available packages, see the orderable addendum at the end of the data sheet.

Typical Application

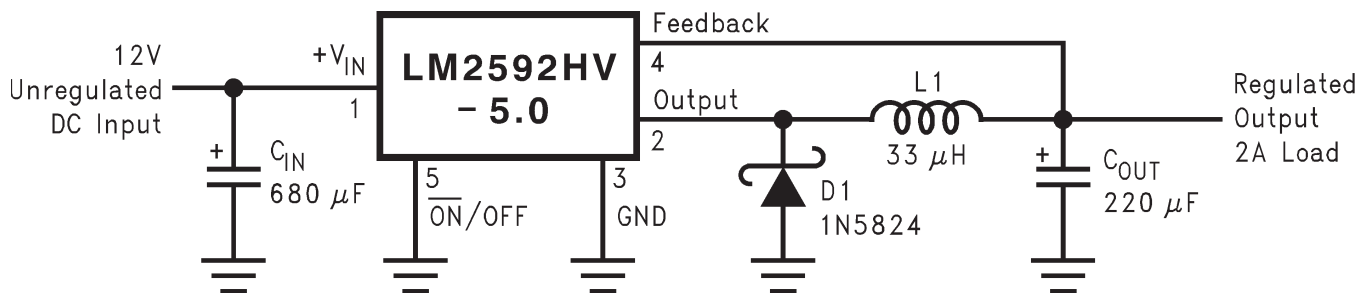

Copyright © 2016, Texas Instruments Incorporated

(Fixed Output Voltage Versions)

LM2592HV

SNVS075E –MAY 2001–REVISED MAY 2016

www.ti.com

Table of Contents

1 Features	1	9 Detailed Description	11
2 Applications	1	9.1 Overview	11
3 Description	1	9.2 Functional Block Diagram	11
4 Revision History	2	9.3 Feature Description	11
5 Description (continued)	3	9.4 Device Functional Modes	13
6 Pin Configuration and Functions	3	10 Application and Implementation	14
7 Specifications	4	10.1 Application Information	14
7.1 Absolute Maximum Ratings	4	10.2 Typical Application	17
7.2 ESD Ratings	4	11 Power Supply Recommendations	20
7.3 Recommended Operating Conditions	4	12 Layout	20
7.4 Thermal Information	4	12.1 Layout Guidelines	20
7.5 Electrical Characteristics LM2592HV-3.3	5	12.2 Layout Examples	21
7.6 Electrical Characteristics LM2592HV-5.0	5	12.3 Thermal Considerations	22
7.7 Electrical Characteristics LM2592HV-ADJ	5	13 Device and Documentation Support	24
7.8 Electrical Characteristics All Output Voltage Versions	6	13.1 Community Resources	24
7.9 Typical Characteristics	7	13.2 Trademarks	24
8 Parameter Measurement Information	10	13.3 Electrostatic Discharge Caution	24
8.1 Test Circuits	10	13.4 Glossary	24
		14 Mechanical, Packaging, and Orderable Information	24

4 Revision History

NOTE: Page numbers for previous revisions may differ from page numbers in the current version.

Changes from Revision D (January 2014) to Revision E**Page**

- Added *ESD Ratings* table, *Feature Description* section, *Device Functional Modes*, *Application and Implementation* section, *Power Supply Recommendations* section, *Layout* section, *Device and Documentation Support* section, and *Mechanical, Packaging, and Orderable Information* section. **1**

Changes from Revision C (April 2013) to Revision D**Page**

- Changed Removed the references to a UVLO circuit with hysteresis. **12**
- Changed Changed fig 31 to the correct circuit. **16**

5 Description (continued)

Features include a $\pm 4\%$ tolerance on output voltage under all conditions of input voltage and output load conditions, and $\pm 15\%$ on the oscillator frequency. External shutdown is included, featuring typically 90- μA standby current. Self-protection features include a two stage current limit for the output switch and an over temperature shutdown for complete protection under fault conditions.

6 Pin Configuration and Functions

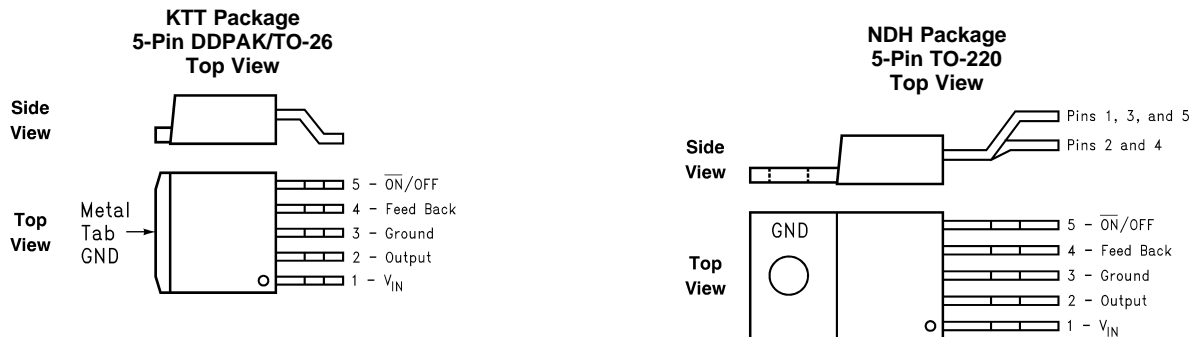

Pin Functions

PIN		I/O	DESCRIPTION
NO.	NAME		
1	$+V_{IN}$	I	This is the positive input supply for the IC switching regulator. A suitable input bypass capacitor must be present at this pin to minimize voltage transients and to supply the switching currents needed by the regulator.
2	Output	O	Internal switch. The voltage at this pin switches between approximately $(+V_{IN} - V_{SAT})$ and approximately -0.5 V , with a duty cycle of V_{OUT}/V_{IN} .
3	Ground	—	Circuit ground.
4	Feedback	I	Senses the regulated output voltage to complete the feedback loop. This pin is directly connected to the Output for the fixed voltage versions, but is set to 1.23 V by means of a resistive divider from the output for the Adjustable version. If a feedforward capacitor is used (Adjustable version), then a negative voltage spike is generated on this pin whenever the output is shorted. This happens because the feedforward capacitor cannot discharge fast enough, and because one end of it is dragged to Ground, the other end goes momentarily negative. To prevent the energy rating of this pin from being exceeded, a small-signal Schottky diode to Ground is recommended for DC input voltages above 40 V whenever a feedforward capacitor is present (See Parameter Measurement Information). Feedforward capacitor values larger than 0.1 μF are not recommended for the same reason, whatever be the DC input voltage.
5	$\overline{\text{ON}}/\text{OFF}$	I	The regulator is in shutdown mode, drawing about 90 μA , when this pin is driven to a high level ($\geq 2\text{ V}$), and is in normal operation when this Pin is left floating or driven to a low level ($\leq 0.6\text{ V}$). The typical value of the threshold is 1.3 V and the voltage on this pin must not exceed 25 V.

LM2592HV

SNVS075E –MAY 2001–REVISED MAY 2016

www.ti.com

7 Specifications**7.1 Absolute Maximum Ratings**⁽¹⁾⁽²⁾

		MIN	MAX	UNIT
Maximum supply voltage (V_{IN})			63	V
\overline{ON} /OFF pin voltage		-0.3	25	V
Feedback pin voltage		-0.3	25	V
Output voltage to ground (steady-state)			-1	V
Power dissipation		Internally limited		
Lead temperature	KTT package	Vapor phase (60 sec.)	215	°C
		Infrared (10 sec.)	245	
	NDH package	Soldering (10 sec.)	260	
Maximum junction temperature		150		°C
Storage temperature, T_{stg}		-65	150	°C

- (1) Stresses beyond those listed under *Absolute Maximum Ratings* may cause permanent damage to the device. These are stress ratings only, which do not imply functional operation of the device at these or any other conditions beyond those indicated under *Recommended Operating Conditions*. Exposure to absolute-maximum-rated conditions for extended periods may affect device reliability.
- (2) If Military/Aerospace specified devices are required, please contact the TI Sales Office/ Distributors for availability and specifications.

7.2 ESD Ratings

		VALUE	UNIT
$V_{(ESD)}$	Electrostatic discharge	Human-body model (HBM), per ANSI/ESDA/JEDEC JS-001 ⁽¹⁾⁽²⁾	±2000 V

- (1) JEDEC document JEP155 states that 500-V HBM allows safe manufacturing with a standard ESD control process.
- (2) The human body model is a 100 pF capacitor discharged through a 1.5k resistor into each pin.

7.3 Recommended Operating Conditions

	MIN	MAX	UNIT
Temperature	-40	125	°C
Supply voltage	4.5	60	V

7.4 Thermal Information

THERMAL METRIC ⁽¹⁾		LM2591HV		UNIT	
		KTT (DDPAK/TO-263)	NDH (TO-220)		
		5 PINS	5 PINS		
$R_{\theta JA}$	Junction-to-ambient thermal resistance	See ⁽²⁾⁽³⁾	50	50	°C/W
$R_{\theta JC(top)}$	Junction-to-case (top) thermal resistance		2	2	°C/W

- (1) For more information about traditional and new thermal metrics, see the *Semiconductor and IC Package Thermal Metrics* application report, [SPRA953](#).
- (2) The package thermal impedance is calculated in accordance to JESD 51-7
- (3) Thermal Resistances were simulated on a 4-layer, JEDEC board

7.5 Electrical Characteristics LM2592HV-3.3

Specifications are for $T_J = 25^\circ\text{C}$ unless otherwise specified.

PARAMETER	TEST CONDITIONS	MIN ⁽¹⁾	TYP ⁽²⁾	MAX ⁽¹⁾	UNIT
SYSTEM PARAMETERS – See Test Circuits⁽³⁾					
V_{OUT} Output voltage	$4.75\text{ V} \leq V_{IN} \leq 60\text{ V}$, $0.2\text{ A} \leq I_{LOAD} \leq 2\text{ A}$		3.3	3.432	V
		over the full operating temperature range	3.135	3.465	
η Efficiency	$V_{IN} = 12\text{ V}$, $I_{LOAD} = 2\text{ A}$		76%		

- (1) All limits ensured at room temperature ($T_J = 25^\circ\text{C}$) unless otherwise specified. All room temperature limits are 100% production tested. All limits at temperature extremes are ensured via correlation using standard Statistical Quality Control (SQC) methods. All limits are used to calculate Average Outgoing Quality Level (AOQL).
- (2) Typical numbers are at 25°C and represent the most likely norm.
- (3) External components such as the catch diode, inductor, input and output capacitors can affect switching regulator system performance. When the LM2592HV is used as shown in the [Test Circuits](#), system performance will be as shown in system parameters section of [Electrical Characteristics](#).

7.6 Electrical Characteristics LM2592HV-5.0

Specifications are for $T_J = 25^\circ\text{C}$ unless otherwise specified.

PARAMETER	TEST CONDITIONS	MIN ⁽¹⁾	TYP ⁽²⁾	MAX ⁽¹⁾	UNIT
SYSTEM PARAMETERS – See Test Circuits⁽³⁾					
V_{OUT} Output voltage	$7\text{ V} \leq V_{IN} \leq 60\text{ V}$, $0.2\text{ A} \leq I_{LOAD} \leq 2\text{ A}$		5	5.2	V
		over the full operating temperature range	4.75	5.25	
η Efficiency	$V_{IN} = 12\text{ V}$, $I_{LOAD} = 2\text{ A}$		81%		

- (1) All limits ensured at room temperature ($T_J = 25^\circ\text{C}$) unless otherwise specified. All room temperature limits are 100% production tested. All limits at temperature extremes are ensured via correlation using standard Statistical Quality Control (SQC) methods. All limits are used to calculate Average Outgoing Quality Level (AOQL).
- (2) Typical numbers are at 25°C and represent the most likely norm.
- (3) External components such as the catch diode, inductor, input and output capacitors can affect switching regulator system performance. When the LM2592HV is used as shown in the [Test Circuits](#), system performance will be as shown in system parameters section of [Electrical Characteristics](#).

7.7 Electrical Characteristics LM2592HV-ADJ

Specifications are for $T_J = 25^\circ\text{C}$ unless otherwise specified.

PARAMETER	TEST CONDITIONS	MIN ⁽¹⁾	TYP ⁽²⁾	MAX ⁽¹⁾	UNIT
SYSTEM PARAMETERS – See Test Circuits⁽³⁾					
V_{FB} Feedback voltage	$4.5\text{ V} \leq V_{IN} \leq 60\text{ V}$, $0.2\text{ A} \leq I_{LOAD} \leq 2\text{ A}$ V_{OUT} programmed for 3 V. Circuit of Test Circuits		1.23	1.267	V
		over the full operating temperature range	1.18	1.28	
η Efficiency	$V_{IN} = 12\text{ V}$, $V_{OUT} = 3\text{ V}$, $I_{LOAD} = 2\text{ A}$		75%		

- (1) All limits ensured at room temperature ($T_J = 25^\circ\text{C}$) unless otherwise specified. All room temperature limits are 100% production tested. All limits at temperature extremes are ensured via correlation using standard Statistical Quality Control (SQC) methods. All limits are used to calculate Average Outgoing Quality Level (AOQL).
- (2) Typical numbers are at 25°C and represent the most likely norm.
- (3) External components such as the catch diode, inductor, input and output capacitors can affect switching regulator system performance. When the LM2592HV is used as shown in the [Test Circuits](#), system performance will be as shown in system parameters section of [Electrical Characteristics](#).

LM2592HV

SNVS075E –MAY 2001–REVISED MAY 2016

www.ti.com

7.8 Electrical Characteristics All Output Voltage Versions

Specifications are for $T_J = 25^\circ\text{C}$, $V_{IN} = 12\text{V}$ for the 3.3-V, 5-V, and adjustable version, and $I_{LOAD} = 500\text{ mA}$ unless otherwise specified.

PARAMETER		TEST CONDITIONS	MIN ⁽¹⁾	TYP ⁽²⁾	MAX ⁽¹⁾	UNIT	
DEVICE PARAMETERS							
I_b	Feedback bias current	Adjustable Version Only, $V_{FB} = 1.3\text{ V}$	over the full operating temperature range	10	50	nA	
				100			
f_O	Oscillator frequency	See ⁽³⁾	over the full operating temperature range	127	150	173	kHz
				110	173		
V_{SAT}	Saturation voltage	$I_{OUT} = 2\text{ A}$ ⁽⁴⁾⁽⁵⁾	over the full operating temperature range	1.1	1.3	V	
				1.4			
DC	Max duty cycle (ON)	See ⁽⁵⁾⁽⁶⁾		100%			
	Min duty cycle (OFF)			0%			
I_{CLIM}	Switch current limit	Peak Current ⁽⁴⁾⁽⁵⁾	over the full operating temperature range	2.4	3	3.7	A
				2.3	4		
I_L	Output leakage current	Output = 0 V		5	50	μA	
		Output = -1 V ⁽⁴⁾⁽⁶⁾⁽⁷⁾		5	30	mA	
I_Q	Operating quiescent current	$\overline{\text{SD}}/\text{SS Pin Open}$ ⁽⁶⁾		5	10	mA	
I_{STBY}	Standby quiescent current	$\overline{\text{SD}}/\text{SS pin} = 0\text{ V}$ ⁽⁷⁾	over the full operating temperature range	90	200	μA	
				250			
ON/OFF CONTROL – See Test Circuits							
V_{IH} V_{IL}	$\overline{\text{ON}}/\text{OFF}$ pin logic input threshold voltage	Low (Regulator ON)	over the full operating temperature range	1.3		V	
		High (Regulator OFF)		2	0.6		
I_H	$\overline{\text{ON}}/\text{OFF}$ pin input current	$V_{LOGIC} = 2.5\text{ V}$ (Regulator OFF)		5	15	μA	
I_L		$V_{LOGIC} = 0.5\text{ V}$ (Regulator ON)		0.02	5	μA	

- (1) All limits ensured at room temperature ($T_J = 25^\circ\text{C}$) unless otherwise specified. All room temperature limits are 100% production tested. All limits at temperature extremes are ensured via correlation using standard Statistical Quality Control (SQC) methods. All limits are used to calculate Average Outgoing Quality Level (AOQL).
- (2) Typical numbers are at 25°C and represent the most likely norm.
- (3) The switching frequency is reduced when the second stage current limit is activated. The amount of reduction is determined by the severity of current overload.
- (4) No diode, inductor or capacitor connected to output pin.
- (5) Feedback pin removed from output and connected to 0 V to force the output transistor switch ON.
- (6) Feedback pin removed from output and connected to 12 V for the 3.3-V, 5-V, and the ADJ. version to force the output transistor switch OFF.
- (7) $V_{IN} = 60\text{ V}$.

7.9 Typical Characteristics

(Circuit of [Test Circuits](#))

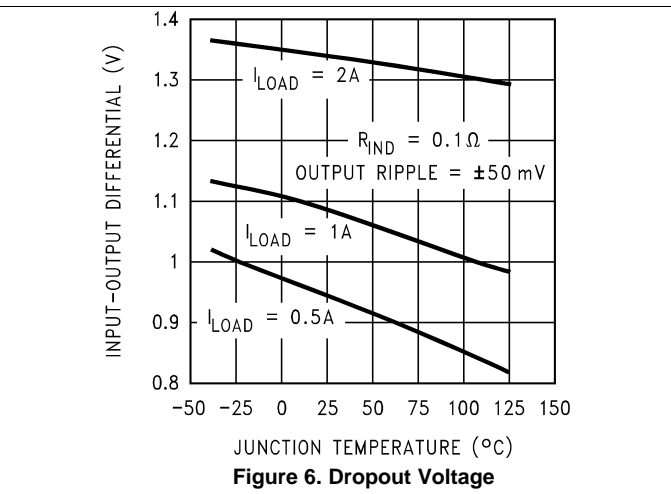
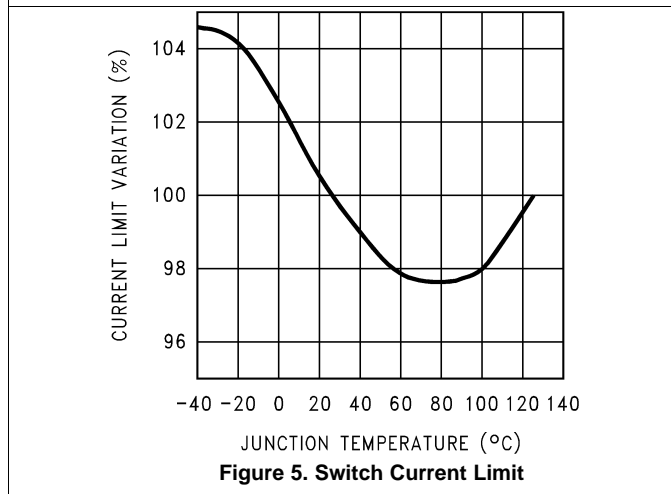
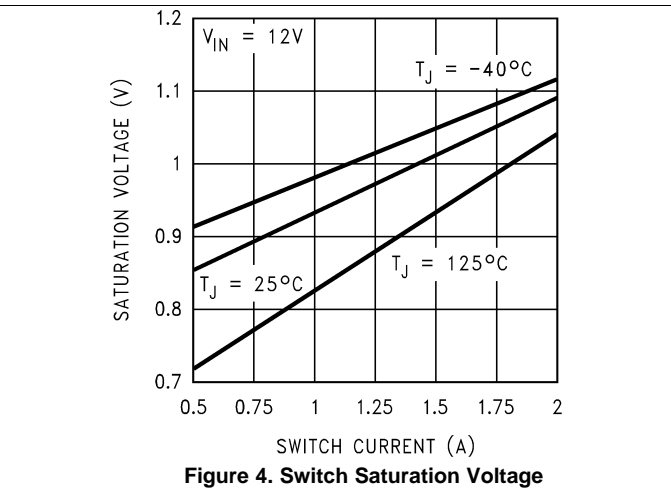
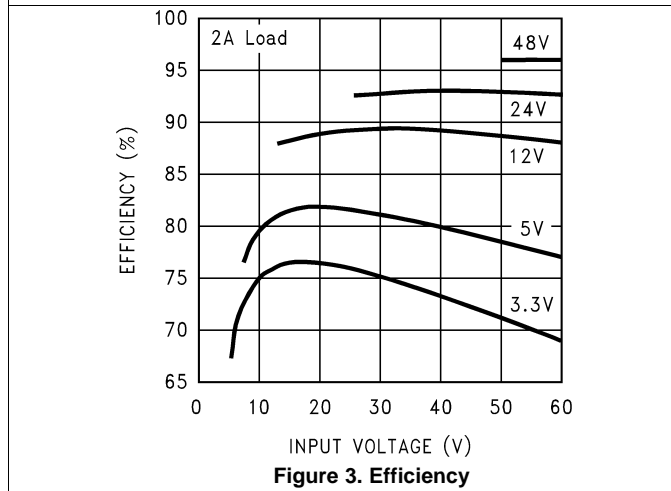
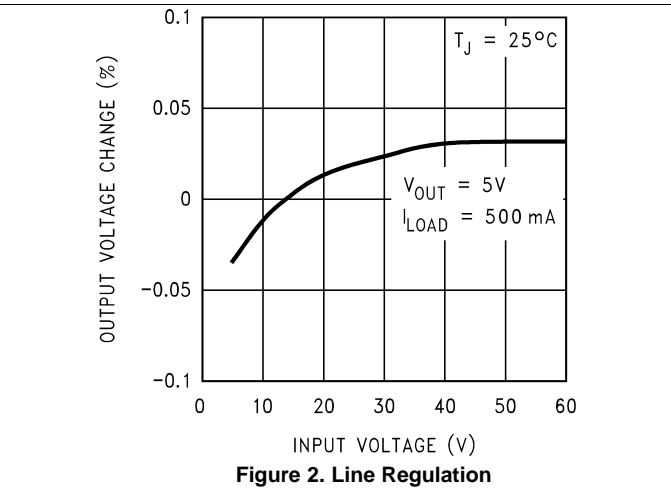
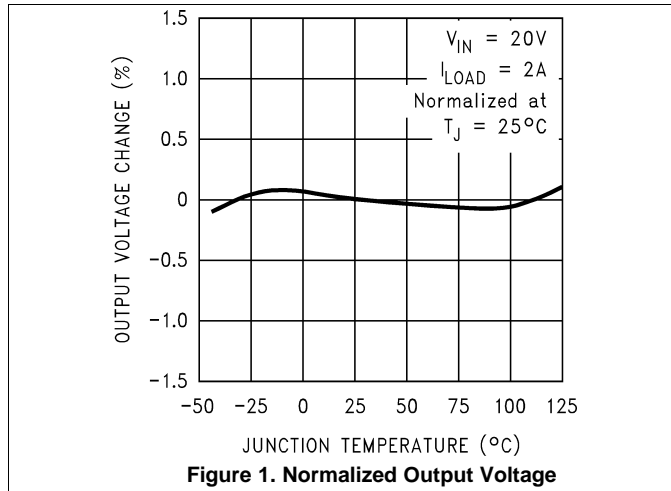

LM2592HV

SNVS075E –MAY 2001–REVISED MAY 2016

www.ti.com

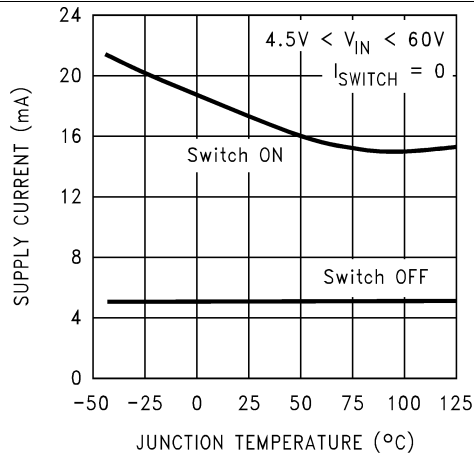
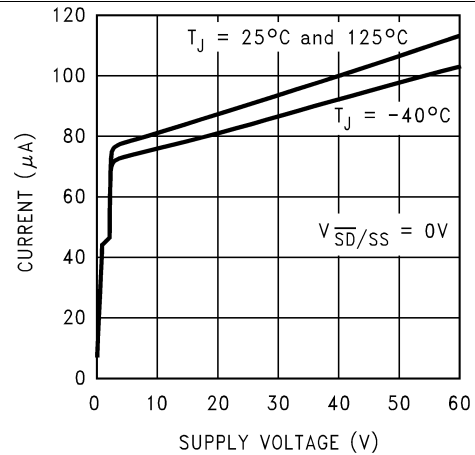
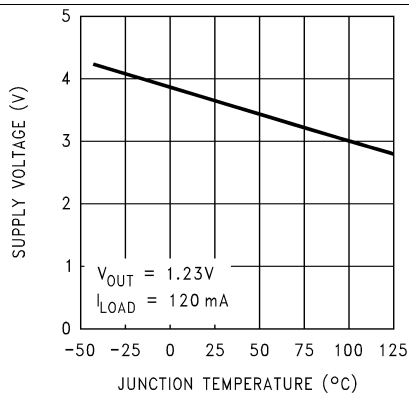
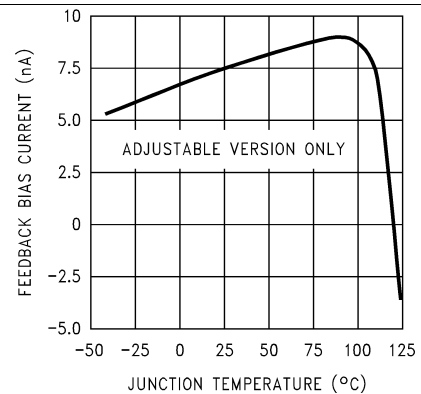
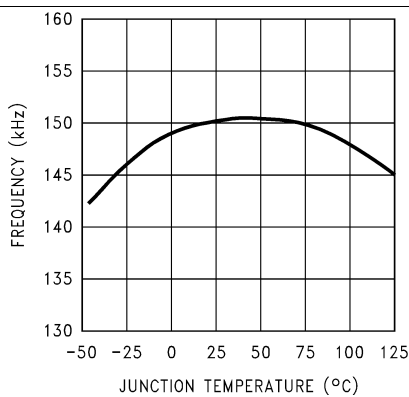
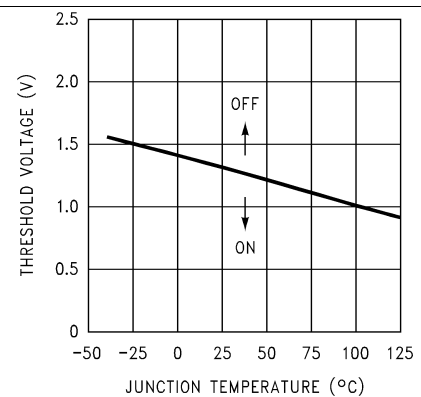
Typical Characteristics (continued)(Circuit of [Test Circuits](#))**Figure 7. Operating Quiescent Current****Figure 8. Shutdown Quiescent Current****Figure 9. Minimum Operating Supply Voltage****Figure 10. Feedback Pin Bias Current****Figure 11. Switching Frequency****Figure 12. ON/OFF Threshold Voltage**

Typical Characteristics (continued)

(Circuit of [Test Circuits](#))

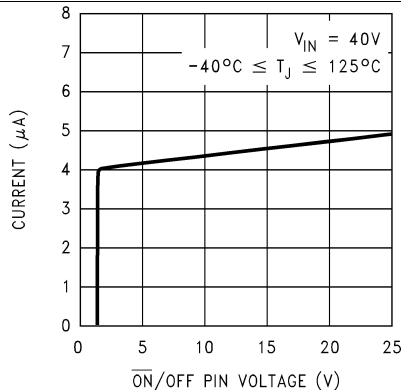

Figure 13. ON/OFF Pin Current (Sinking)

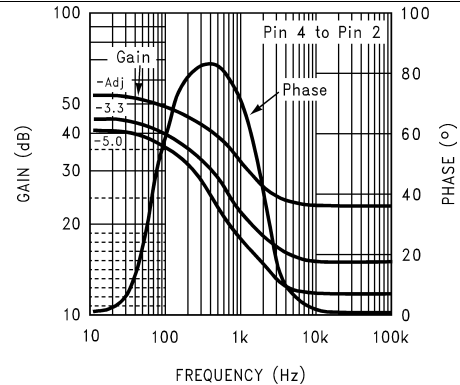
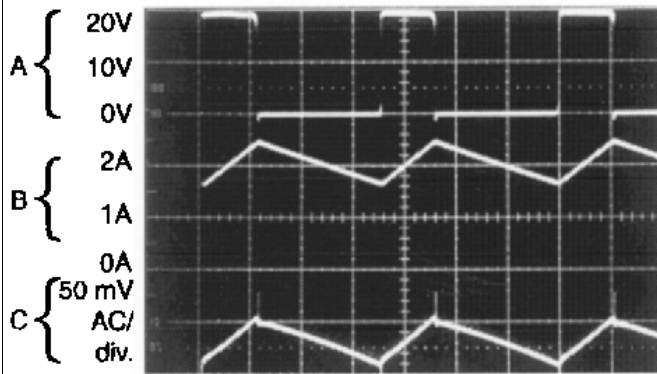
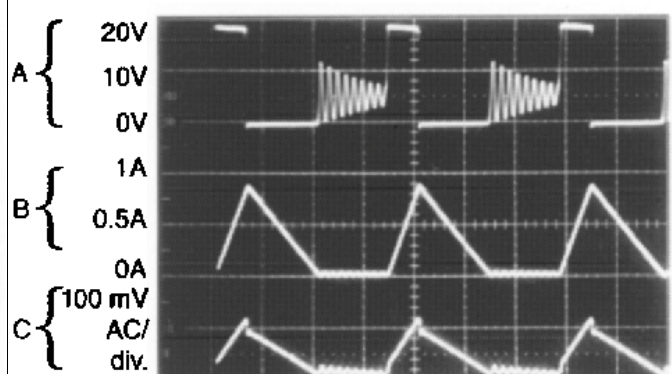

Figure 14. Internal Gain-Phase Characteristics



Continuous Mode Switching Waveforms $V_{IN} = 20V$, $V_{OUT} = 5V$, $I_{LOAD} = 2A$ $L = 32 \mu H$, $C_{OUT} = 220 \mu F$, $C_{OUT} ESR = 50 m\Omega$
Output Pin Voltage, 10V/div.
Inductor Current 1A/div.
Output Ripple Voltage, 50 mV/div.

Figure 15. Horizontal Time Base: 2 μs /div



Discontinuous Mode Switching Waveforms $V_{IN} = 20V$, $V_{OUT} = 5V$, $I_{LOAD} = 500 mA$ $L = 10 \mu H$, $C_{OUT} = 330 \mu F$, $C_{OUT} ESR = 45 m\Omega$
Output Pin Voltage, 10V/div.
Inductor Current 0.5A/div.
Output Ripple Voltage, 100 mV/div.

Figure 16. Horizontal Time Base: 2 μs /div

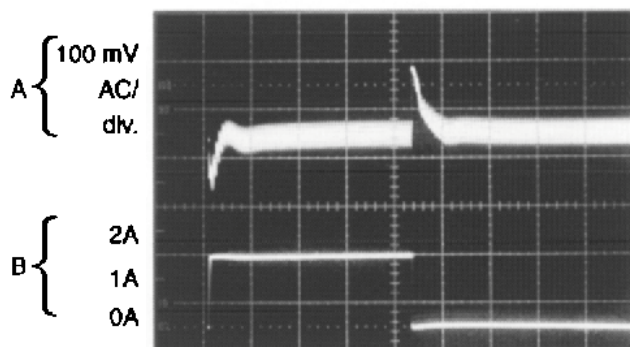

Load Transient Response for Continuous Mode $V_{IN} = 20V$, $V_{OUT} = 5V$, $I_{LOAD} = 500 mA$ to 2A $L = 32 \mu H$, $C_{OUT} = 220 \mu F$, $C_{OUT} ESR = 50 m\Omega$
Output Voltage, 100 mV/div. (AC)
500 mA to 2A Load Pulse

Figure 17. Horizontal Time Base: 50 μs /div

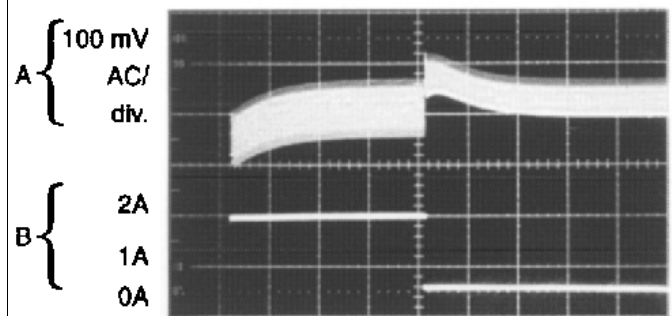

Load Transient Response for Discontinuous Mode $V_{IN} = 20V$, $V_{OUT} = 5V$, $I_{LOAD} = 500 mA$ to 2A $L = 10 \mu H$, $C_{OUT} = 330 \mu F$, $C_{OUT} ESR = 45 m\Omega$
Output Voltage, 100 mV/div. (AC)
500-mA to 2-A Load Pulse

Figure 18. Horizontal Time Base: 200 μs /div

LM2592HV

SNVS075E –MAY 2001–REVISED MAY 2016

www.ti.com

8 Parameter Measurement Information

8.1 Test Circuits

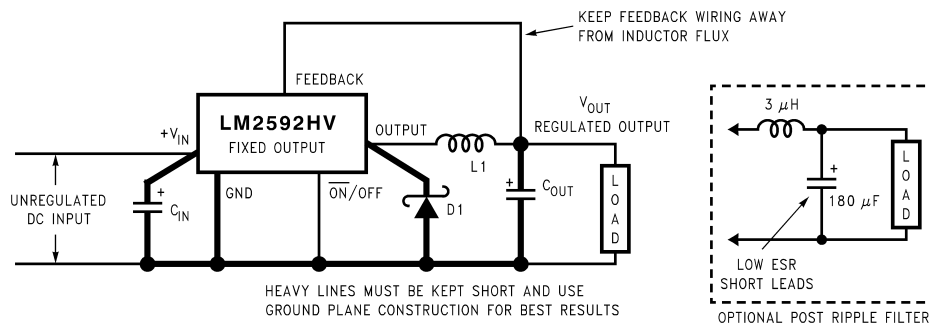

Component Values shown are for $V_{IN} = 15\text{ V}$,

$V_{OUT} = 5\text{ V}$, $I_{LOAD} = 2\text{ A}$.

C_{IN} — 470- μF , 50-V, Aluminum Electrolytic Nichicon *PM Series*

C_{OUT} — 220- μF , 25-V Aluminum Electrolytic, Nichicon *PM Series*

D1 — 3.3-A, 60-V Schottky Rectifier, 31DQ06 (International Rectifier)

L1 — 33 μH , See [Application Curves](#)

Figure 19. Fixed Output Voltage Versions

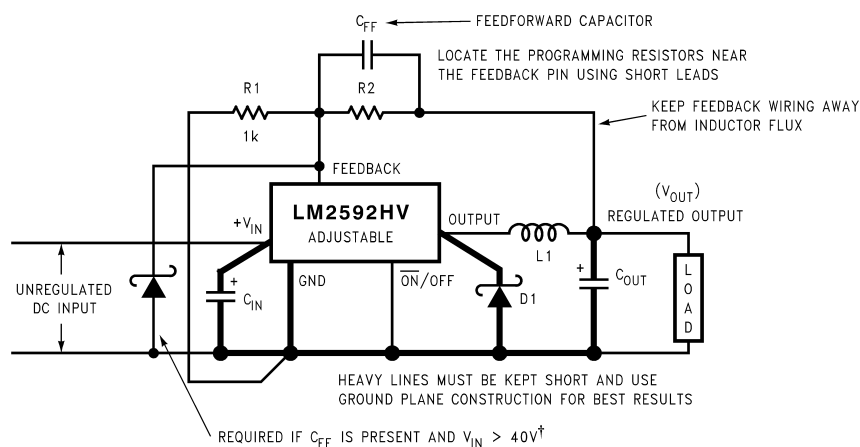

Select R_1 to be approximately 1 k Ω , use a 1% resistor for best stability.

Component Values shown are for $V_{IN} = 20\text{ V}$,

$V_{OUT} = 10\text{ V}$, $I_{LOAD} = 2\text{ A}$.

C_{IN} : — 470- μF , 35-V, Aluminum Electrolytic Nichicon *PM Series*

C_{OUT} : — 220- μF , 35-V Aluminum Electrolytic, Nichicon *PM Series*

D1 — 3.3-A, 60-V Schottky Rectifier, 31DQ06 (International Rectifier)

L1 — 47 μH , See [Application Curves](#)

R_1 — 1 k Ω , 1%

R_2 — 7.15k, 1%

C_{FF} — 3.3 nF

Typical Values

C_{SS} — 0.1 μF

C_{DELAY} — 0.1 μF

R_{PULLUP} — 4.7k (use 22k if V_{OUT} is $\geq 45\text{ V}$)

† Small signal Schottky diode to prevent damage to feedback pin by negative spike when output is shorted. Required if $V_{IN} > 40\text{ V}$

Figure 20. Adjustable Output Voltage Versions

9 Detailed Description

9.1 Overview

The LM2592HV SIMPLE SWITCHER[®] regulator is an easy-to-use, nonsynchronous, step-down DC-DC converter with a wide input voltage range up to 60 V. The regulator is capable of delivering up to 2-A DC load current with excellent line and load regulation. These devices are available in fixed output voltages of 3.3 V, 5 V, and an adjustable output version. The family requires few external components, and the pin arrangement was designed for simple, optimum PCB layout.

9.2 Functional Block Diagram

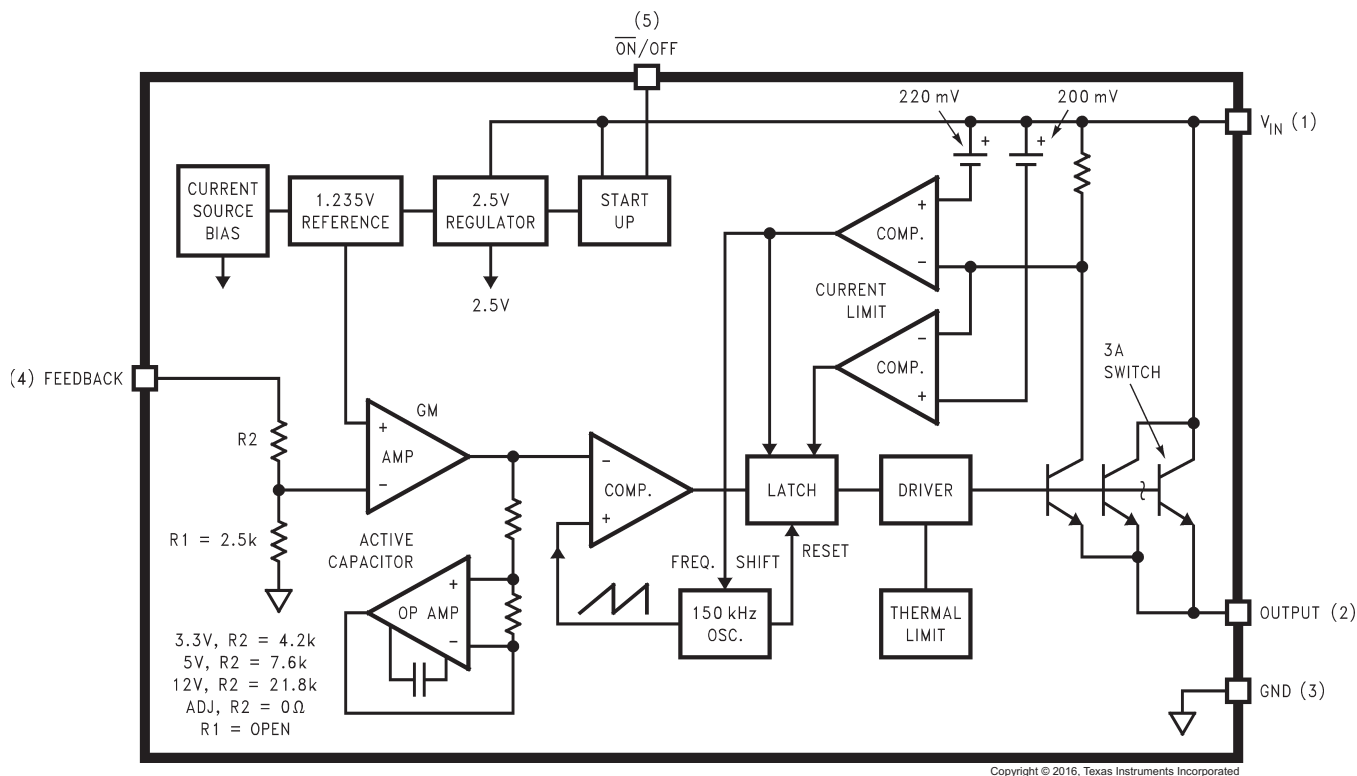

9.3 Feature Description

9.3.1 Delayed Start-Up

The circuit in [Figure 21](#) uses the $\overline{\text{ON/OFF}}$ pin to provide a time delay between the time the input voltage is applied and the time the output voltage comes up (only the circuitry pertaining to the delayed start-up is shown). As the input voltage rises, the charging of capacitor C1 pulls the $\overline{\text{ON/OFF}}$ pin high, keeping the regulator off. When the input voltage reaches its final value and the capacitor stops charging, the resistor R₂ pulls the $\overline{\text{ON/OFF}}$ pin low, thus allowing the circuit to start switching. Resistor R₁ is included to limit the maximum voltage applied to the $\overline{\text{ON/OFF}}$ pin (maximum of 25 V), reduces power supply noise sensitivity, and also limits the capacitor, C1, discharge current. When high input ripple voltage exists, avoid long delay time, because this ripple can be coupled into the $\overline{\text{ON/OFF}}$ pin and cause problems.

This delayed start-up feature is useful in situations where the input power source is limited in the amount of current it can deliver. It allows the input voltage to rise to a higher voltage before the regulator starts operating. Buck regulators require less input current at higher input voltages.

LM2592HV

SNVS075E –MAY 2001–REVISED MAY 2016

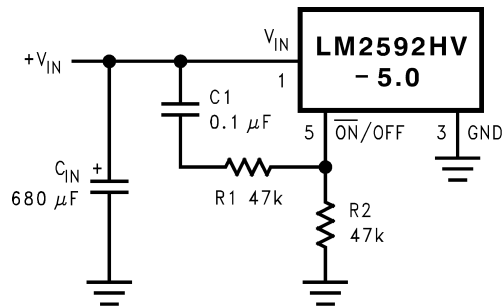
www.ti.com**Feature Description (continued)****Figure 21. Delayed Start-Up****9.3.2 Undervoltage Lockout**

Some applications require the regulator to remain off until the input voltage reaches a predetermined voltage. An undervoltage lockout feature applied to a buck regulator is shown in [Figure 22](#), while [Figure 23](#) applies the same feature to an inverting circuit. The circuit in [Figure 22](#) features a constant threshold voltage for turnon and turnoff (Zener voltage plus approximately one volt). The circuit in [Figure 23](#) has a turnon threshold of about 13 V and a turnoff threshold of about 8 V. The amount of hysteresis is approximately equal to the output voltage. If Zener voltages greater than 25 V are used, an additional 47-k Ω resistor is needed from the ON/OFF pin to the ground pin to stay within the 25-V maximum limit of the ON/OFF pin.

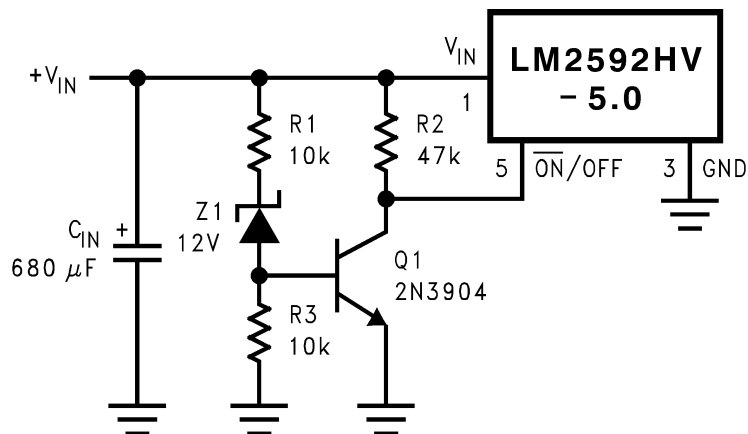
**Figure 22. Undervoltage Lockout for Buck Regulator**

Feature Description (continued)

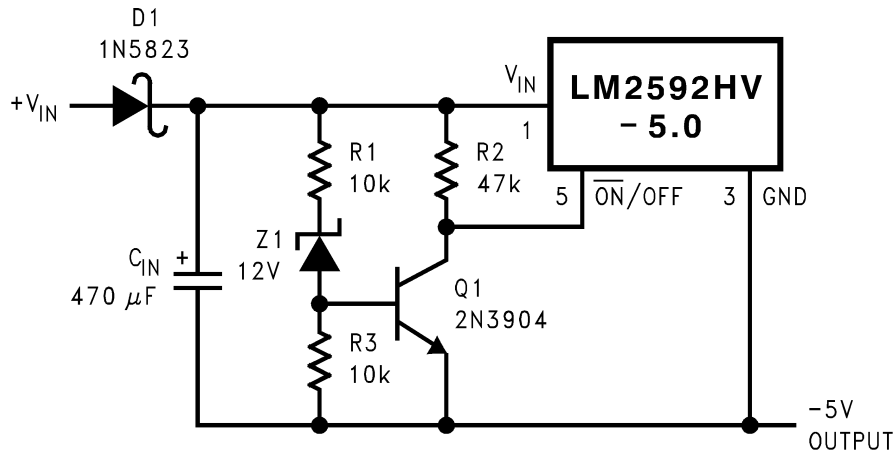

This circuit has hysteresis
 Regulator starts switching at $V_{IN} = 13\text{ V}$.
 Regulator stops switching at $V_{IN} = 8\text{ V}$

Figure 23. Undervoltage Lockout for Inverting Regulator

9.4 Device Functional Modes

9.4.1 Shutdown Mode

The $\overline{\text{ON/OFF}}$ pin provides electrical ON and OFF control for the LM2592HV. When the voltage of this pin is higher than 2 V, the device is shutdown mode. The typical standby current in this mode is 90 μA .

9.4.2 Active Mode

When the $\overline{\text{ON/OFF}}$ pin is left floating or pull below 0.6 V, the device will start switching and the output voltage will rise until it reaches a normal regulation voltage.

LM2592HV

SNVS075E –MAY 2001–REVISED MAY 2016

www.ti.com

10 Application and Implementation

NOTE

Information in the following applications sections is not part of the TI component specification, and TI does not warrant its accuracy or completeness. TI's customers are responsible for determining suitability of components for their purposes. Customers should validate and test their design implementation to confirm system functionality.

10.1 Application Information

10.1.1 Feedforward Capacitor

(Adjustable Output Voltage Version)

C_{FF} – A feedforward Capacitor C_{FF} , shown across R2 in [Test Circuits](#), is used when the output voltage is greater than 10 V or when C_{OUT} has a very low ESR. This capacitor adds lead compensation to the feedback loop and increases the phase margin for better loop stability.

If the output voltage ripple is large (>5% of the nominal output voltage), this ripple can be coupled to the feedback pin through the feedforward capacitor and cause the error comparator to trigger the error flag. In this situation, adding a resistor, R_{FF} , in series with the feedforward capacitor, approximately 3 times R1, will attenuate the ripple voltage at the feedback pin.

10.1.2 Input Capacitor

C_{IN} – A low ESR aluminum or tantalum bypass capacitor is needed between the input pin and ground pin. It must be located near the regulator using short leads. This capacitor prevents large voltage transients from appearing at the input, and provides the instantaneous current needed each time the switch turns on.

The important parameters for the Input capacitor are the voltage rating and the RMS current rating. Because of the relatively high RMS currents flowing in a buck regulator's input capacitor, this capacitor must be chosen for its RMS current rating rather than its capacitance or voltage ratings, although the capacitance value and voltage rating are directly related to the RMS current rating. The voltage rating of the capacitor and its RMS ripple current capability must never be exceeded.

10.1.3 Output Capacitor

C_{OUT} – An output capacitor is required to filter the output and provide regulator loop stability. Low impedance or low ESR Electrolytic or solid tantalum capacitors designed for switching regulator applications must be used. When selecting an output capacitor, the important capacitor parameters are the 100-kHz Equivalent Series Resistance (ESR), the RMS ripple current rating, voltage rating, and capacitance value. For the output capacitor, the ESR value is the most important parameter. The ESR must generally not be less than 100 m Ω or there will be loop instability. If the ESR is too large, efficiency and output voltage ripple are effected, so ESR must be chosen carefully.

10.1.4 Catch Diode

Buck regulators require a diode to provide a return path for the inductor current when the switch turns off. This must be a fast diode and must be located close to the LM2592HV using short leads and short printed-circuit traces.

Because of their very fast switching speed and low forward voltage drop, Schottky diodes provide the best performance, especially in low output voltage applications (5 V and lower). Ultra-fast recovery, or high-efficiency rectifiers are also a good choice, but some types with an abrupt turnoff characteristic may cause instability or EMI problems. Ultra-fast recovery diodes typically have reverse recovery times of 50 ns or less. The diode must be chosen for its average/RMS current rating and maximum voltage rating. The voltage rating of the diode must be greater than the DC input voltage (not the output voltage).

Application Information (continued)

10.1.5 Inverting Regulator

The circuit in [Figure 24](#) converts a positive input voltage to a negative output voltage with a common ground. The circuit operates by bootstrapping the regulator's ground pin to the negative output voltage. Then, after grounding the feedback pin, the regulator senses the inverted output voltage and regulates it.

This example uses the LM2592HV-5.0 to generate a -5-V output, but other output voltages are possible by selecting other output voltage versions, including the adjustable version. Because this regulator topology can produce an output voltage that is either greater than or less than the input voltage, the maximum output current greatly depends on both the input and output voltage.

To determine how much load current is possible before the internal device current limit is reached (and power limiting occurs), the system must be evaluated as a buck-boost configuration rather than as a buck. The peak switch current in amperes, for such a configuration is given as [Equation 1](#):

$$I_{PEAK} = I_{LOAD} \times \left(\frac{V_{IN} + V_{OUT}}{V_{IN}} \right) + \frac{V_{IN} \times V_{OUT} \times 10^6}{2 \times L \times f \times (V_{IN} + V_{OUT})}$$

where

- L is in μH
- and f is in Hz
- The maximum possible load current I_{LOAD} is limited by the requirement that $I_{PEAK} \leq I_{CLIM}$ (1)

While checking for this, take I_{CLIM} to be the lowest possible current limit value (minimum across tolerance and temperature is 2.3 A for the LM2592HV). Also to account for inductor tolerances, take the minimum value of Inductance for L in [Equation 1](#) (typically 20% less than the nominal value). Further, [Equation 1](#) disregards the drop across the switch and the diode. This is equivalent to assuming 100% efficiency, which is never so. Therefore expect I_{PEAK} to be an additional 10 to 20% higher than calculated from the above equation.

See Application Note [AN-1157](#) for examples based on positive to negative configuration.

The maximum voltage appearing across the regulator is the absolute sum of the input and output voltage, and this must be limited to a maximum of 60 V. For example, when converting +20 V to -12 V, the regulator would see 32 V between the input pin and ground pin. The LM2592HV has a maximum input voltage spec of 60 V.

Additional diodes are required in this regulator configuration. Diode D1 is used to isolate input voltage ripple or noise from coupling through the C_{IN} capacitor to the output, under light or no load conditions. Also, this diode isolation changes the topology to closely resemble a buck configuration thus providing good closed loop stability. A Schottky diode is recommended for low input voltages, (because of its lower voltage drop) but for higher input voltages, a fast recovery diode could be used.

Without diode D3, when the input voltage is first applied, the charging current of C_{IN} can pull the output positive by several volts for a short period of time. Adding D3 prevents the output from going positive by more than a diode voltage.

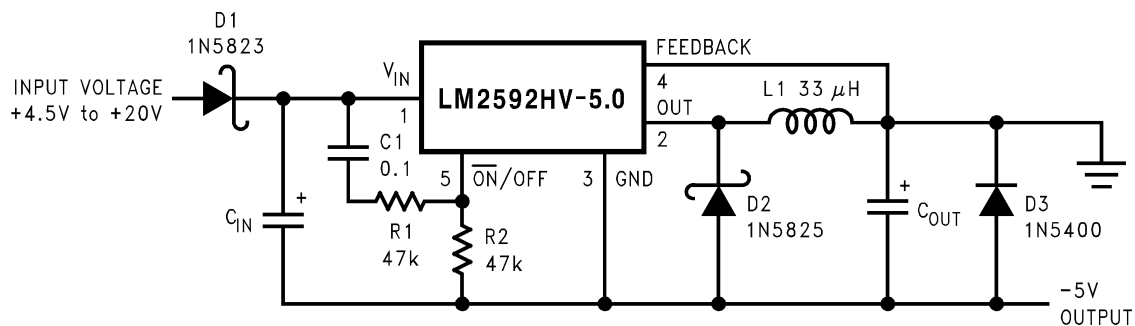

C_{IN} — 68- μF , 25-V Tant. Sprague 595D

470- μF , 50-V Elec. Panasonic HFQ

C_{OUT} — 47- μF , 20-V Tant. Sprague 595D

220- μF , 25-V Elec. Panasonic HFQ

Figure 24. Inverting -5-V Regulator With Delayed Start-Up

LM2592HV

SNVS075E –MAY 2001–REVISED MAY 2016

www.ti.com

Application Information (continued)

Because of differences in the operation of the inverting regulator, the standard design procedure is not used to select the inductor value. In the majority of designs, a 33- μH , 4-A inductor is the best choice. Capacitor selection can also be narrowed down to just a few values.

This type of inverting regulator can require relatively large amounts of input current when starting up, even with light loads. Input currents as high as the LM2592HV current limit (approximately 4 A) are needed for at least 2 ms or more, until the output reaches its nominal output voltage. The actual time depends on the output voltage and the size of the output capacitor. Input power sources that are current-limited or sources that can not deliver these currents without getting loaded down, may not work correctly. Because of the relatively high start-up currents required by the inverting topology, the delayed start-up feature (C_1 , R_1 , and R_2) shown in Figure 24 is recommended. By delaying the regulator start-up, the input capacitor is allowed to charge up to a higher voltage before the switcher begins operating. A portion of the high input current needed for start-up is now supplied by the input capacitor C_{IN}). For severe start-up conditions, the input capacitor can be made much larger than normal.

10.1.6 Inverting Regulator Shutdown Methods

Using the $\overline{\text{ON/OFF}}$ pin in a standard buck configuration is simple. To turn the regulator ON, pull the $\overline{\text{ON/OFF}}$ pin below 1.3 V (at 25°C referenced to ground). To shut the regulator OFF, pull the $\overline{\text{ON/OFF}}$ pin above 1.3 V. With the inverting configuration, some level shifting is required, because the ground pin of the regulator is no longer at ground, but is now setting at the negative output voltage level. Two different shutdown methods for inverting regulators are shown in Figure 25 and Figure 26.

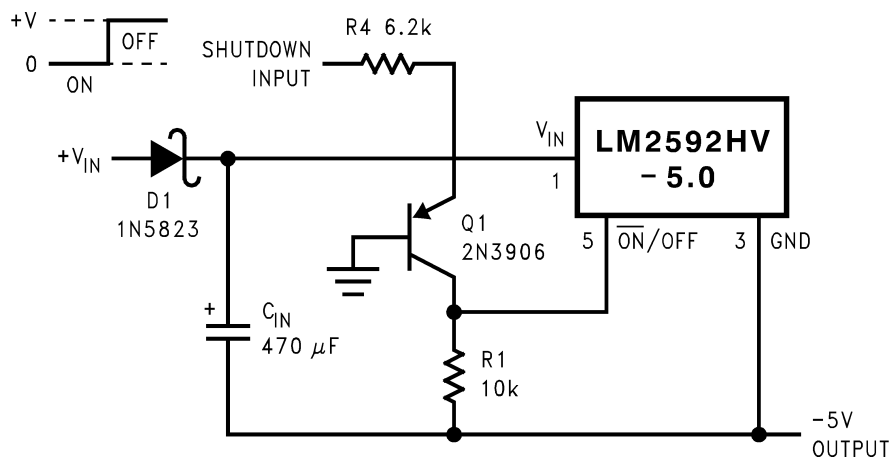

Figure 25. Inverting Regulator Ground Referenced Shutdown

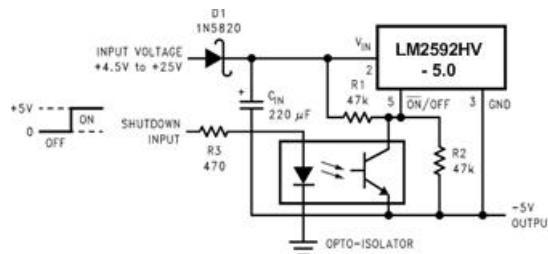
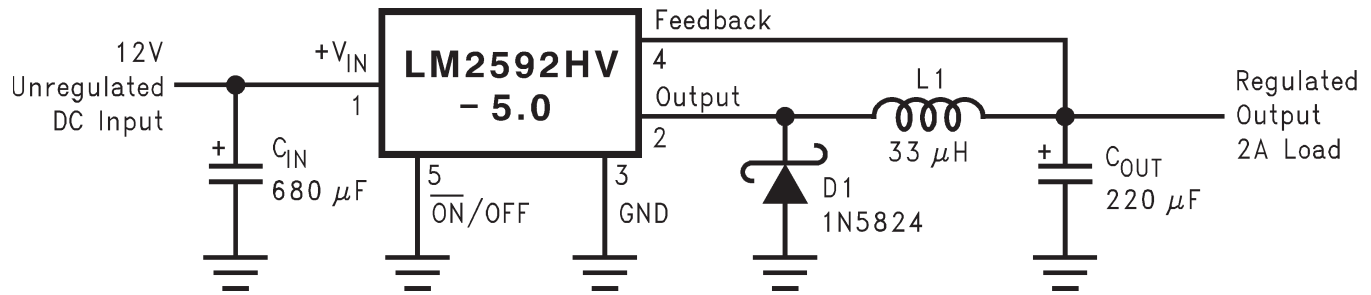

Figure 26. Inverting Regulator Ground Referenced Shutdown Using Opto-isolator Device

10.2 Typical Application



Copyright © 2016, Texas Instruments Incorporated

Figure 27. Typical Application

10.2.1 Design Requirements

Table 1 lists the parameters for this design example.

Table 1. Example Parameters

PARAMETER	EXAMPLE VALUE
Regulated output voltage, V_{OUT}	20 V
Maximum input voltage, $V_{IN(max)}$	24 V
Maximum load current, $I_{LOAD(max)}$	1 A
Switching frequency, F	Fixed at a nominal 150 kHz

10.2.2 Detailed Design Procedure

10.2.2.1 Inductor Selection Procedure

See application note AN-1197 ([SNVA038](#)) for detailed information on selecting inductors for buck converters. For a quick-start, the designer may refer to the nomographs provided in [Figure 28](#) to [Figure 30](#). To give designers more options of available inductors, the nomographs provide the required inductance and also the energy in the core expressed in microjoules (μJ), as an alternative to just prescribing custom parts. The following points must be highlighted:

- The Energy values shown on the nomographs apply to steady operation at the corresponding x-coordinate (rated maximum load current). However, under start-up, without soft start, or a short circuit on the output, the current in the inductor will momentarily/repetitively hit the current limit I_{CLIM} of the device, and this current could be much higher than the rated load, I_{LOAD} . This represents an overload situation, and can cause the inductor to saturate (if it has been designed only to handle the energy of steady operation). However, most types of core structures used for such applications have a large inherent air gap (for example, powdered iron types or ferrite rod inductors), so the inductance does not fall off too sharply under an overload. The device is usually able to protect itself by preventing the current from exceeding I_{CLIM} . However, if the DC input voltage of the regulator is over 40 V, the current can slew up so fast under core saturation that the device may not be able to act fast enough to restrict the current. The current can then rise without limit until the device destructs. Therefore to ensure reliability, it is recommended, that if the DC Input Voltage exceeds 40 V, the inductor must ALWAYS be sized to handle an instantaneous current equal to I_{CLIM} without saturating, irrespective of the type of core structure/material.
- The energy under steady operation is calculated in [Equation 2](#):

$$e = \frac{1}{2} \times L \times I_{PEAK}^2 \mu\text{J}$$

where

- L is in μH
- and I_{PEAK} is the peak of the inductor current waveform with the regulator delivering I_{LOAD} (2)

These are the energy values shown in the nomographs. See Example 1.

- The energy under overload is calculated in [Equation 3](#):

LM2592HV

SNVS075E –MAY 2001–REVISED MAY 2016

www.ti.com

$$e_{\text{CLIM}} = \frac{1}{2} \times L \times I_{\text{CLIM}}^2 \mu\text{J} \quad (3)$$

If $V_{\text{IN}} > 40$ V, the inductor must be sized to handle e_{CLIM} instead of the steady energy values. The worst case I_{CLIM} for the LM2592HV is 4 A. The energy rating depends on the Inductance. See [Figure 28](#) through [Figure 30](#).

- The nomographs were generated by allowing a greater amount of percentage current ripple in the inductor as the maximum rated load decreases (see [Figure 31](#)). This was done to allow smaller inductors to be used at light loads. [Figure 31](#), however, shows only the *median* value of the current ripple. In reality there may be a great spread around this because the nomographs approximate the exact calculated inductance to standard available values. It is a good idea to refer to [AN-1197](#) for detailed calculations if a certain maximum inductor current ripple is required for various possible reasons. Also consider the rather wide tolerance on the nominal inductance of commercial inductors.
- [Figure 30](#) shows the inductor selection curves for the Adjustable version. The y-axis is 'Et', in $V\mu\text{s}$. It is the applied volts across the inductor during the ON time of the switch ($V_{\text{IN}} - V_{\text{SAT}} - V_{\text{OUT}}$) multiplied by the time for which the switch is on in μs . See Example 3.

Example 1: ($V_{\text{IN}} \leq 40$ V) LM2592HV-5.0, $V_{\text{IN}} = 24$ V, Output 5 V at 1 A

- A first pass inductor selection is based upon *Inductance and rated max load current*. Choose an inductor with the inductance value indicated by the nomograph (see [Figure 29](#)) and a current rating equal to the maximum load current. We therefore quick-select a 68- μH , 1-A inductor (designed for 150-kHz operation) for this application.
- Confirm that it is rated to handle 50 μJ (see [Figure 29](#)) by either estimating the peak current or by a detailed calculation as shown in [AN-1197](#) ([SNVS038](#)). Also, confirm that the losses are acceptable.

Example 2: ($V_{\text{IN}} > 40$ V) LM2592HV-5.0, $V_{\text{IN}} = 48$ V, Output 5 V at 1.5 A

- A first pass inductor selection is based upon *Inductance and the switch current limit*. We choose an inductor with the Inductance value indicated by the nomograph (see [Figure 29](#)) and a current rating equal to I_{CLIM} . We therefore quick-select a 68- μH , 4-A inductor (designed for 150-kHz operation) for this application.
- Confirm that it is rated to handle e_{CLIM} by the procedure shown in [AN-1197](#) ([SNVA038](#)) and that the losses are acceptable. Here e_{CLIM} is calculated in [Equation 4](#):

$$e_{\text{CLIM}} = \frac{1}{2} \times 68 \times 4^2 = 544 \mu\text{J} \quad (4)$$

Example 3: ($V_{\text{IN}} \leq 40$ V) LM2592HV-ADJ, $V_{\text{IN}} = 20$ V, Output 10 V at 2 A

- Because input voltage is less than 40 V, a first pass inductor selection is based upon inductance and rated maximum load current. Choose an inductor with the inductance value indicated by the nomograph [Figure 30](#) and a current rating equal to the maximum load. But first calculate Et for the given application. The duty cycle is calculated in [Equation 5](#):

$$D = \frac{V_{\text{OUT}} + V_{\text{D}}}{V_{\text{IN}} - V_{\text{SAT}} + V_{\text{D}}}$$

where

- V_{D} is the drop across the catch diode (≈ 0.5 V for a Schottky)
- and V_{SAT} the drop across the switch (≈ 1.5 V)

Which turns into [Equation 6](#)

$$D = \frac{10 + 0.5}{20 - 1.5 + 0.5} = 0.55 \quad (6)$$

And the switch ON time is calculated by [Equation 7](#):

$$t_{\text{ON}} = \frac{D}{f} \times 10^6 \mu\text{s}$$

where

- f is the switching frequency in Hz

Which turns into [Equation 8](#):

$$\begin{aligned}
 Et &= (V_{IN} - V_{SAT} - V_{OUT}) \times t_{ON} \\
 &= (20 - 1.5 - 10) \times \frac{0.55}{150000} \times 10^6 \text{ V}\mu\text{secs} \\
 &= 31.3 \text{ V}\mu\text{secs}
 \end{aligned}
 \tag{8}$$

Therefore, looking at [Figure 28](#) we quick-select a 47-μH, 2-A inductor (designed for 150-kHz operation) for this application.

2. Confirm that the inductor is rated to handle 200 μJ (see [Figure 30](#)) by the procedure shown in AN-1197 ([SNVA038](#)) and that the losses are acceptable. (If the DC input voltage is greater than 40 V, consider e_{CLIM} as shown in Example 2.)

This completes the simplified inductor selection procedure. For more general applications and better optimization, see AN-1197 ([SNVA038](#)).

10.2.3 Application Curves

(For Continuous Mode Operation)

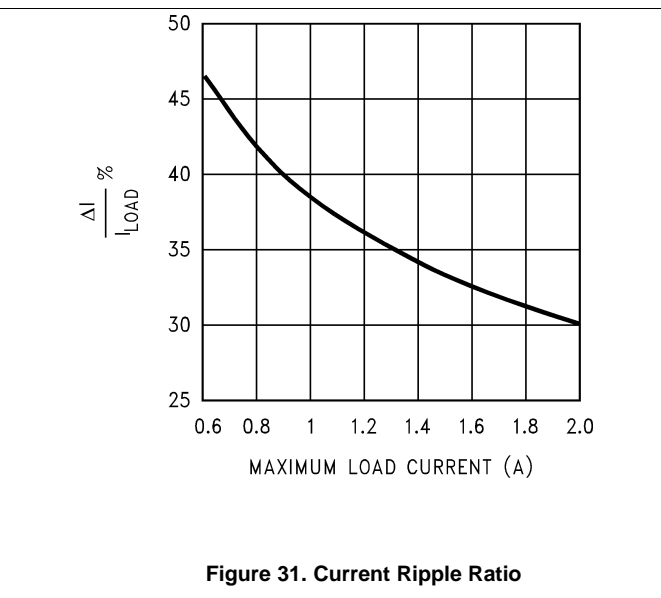
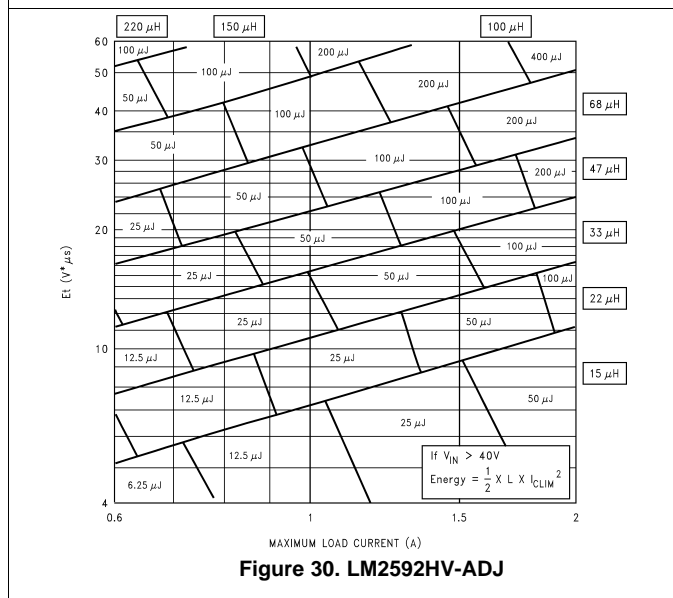
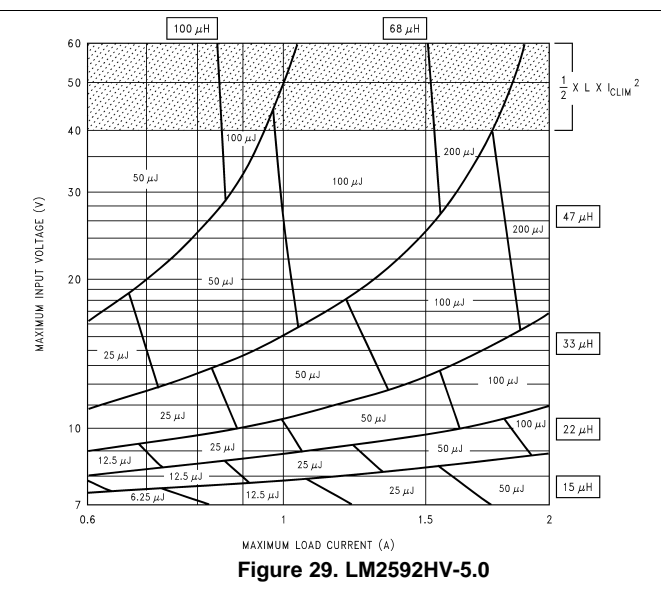
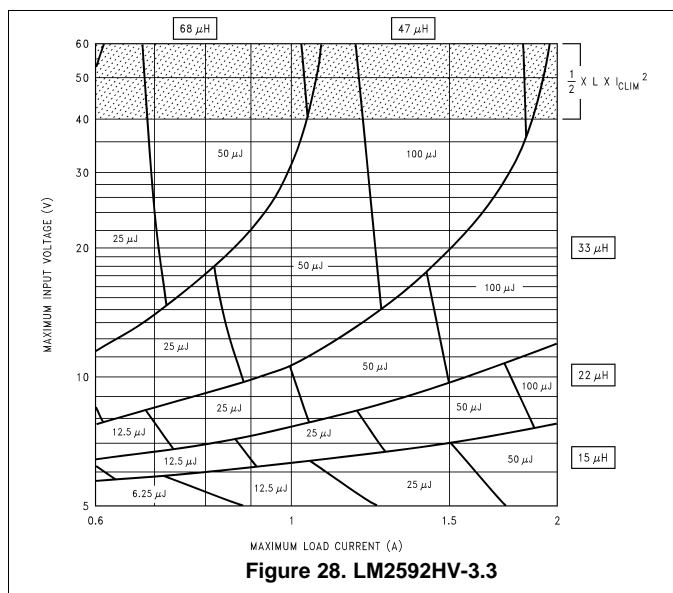

LM2592HV

SNVS075E –MAY 2001–REVISED MAY 2016

www.ti.com

11 Power Supply Recommendations

The LM2592HV is designed to operate from an input voltage supply up to 60 V. This input supply must be well regulated, able to withstand the maximum input current, and maintain a stable voltage.

12 Layout

12.1 Layout Guidelines

As in any switching regulator, layout is very important. Rapid switching currents associated with wiring inductance can generate voltage transients, which can cause problems. For minimal inductance and ground loops (see [Test Circuits](#)), the wires indicated by heavy lines must be wide printed-circuit traces and must be kept as short as possible. For best results, external components must be placed as close to the switcher IC as possible using ground plane construction or single-point grounding.

If open-core inductors are used, take special care as to the location and positioning of this type of inductor. Allowing the inductor flux to intersect sensitive feedback, IC ground path, and C_{OUT} wiring can cause problems.

When using the adjustable version, take special care as to the location of the feedback resistors and the associated wiring. Physically place both resistors near the IC, and route the wiring away from the inductor, especially an open core type of inductor.

12.2 Layout Examples

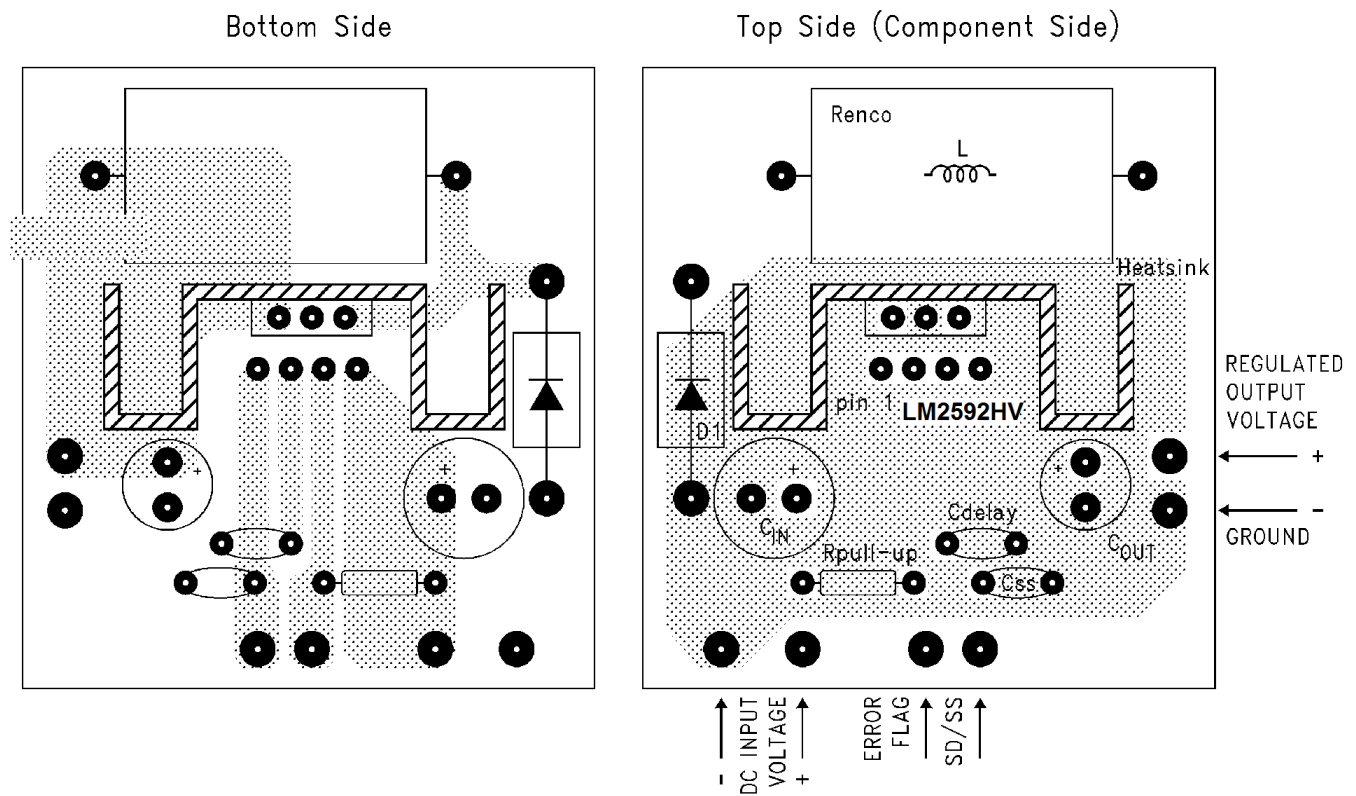

C_{IN} = 470- μ F, 50-V, aluminum electrolytic Panasonic *HFQ Series*
 C_{OUT} = 330- μ F, 35-V, aluminum electrolytic Panasonic *HFQ Series*
 D1 = 5-A, 40-V Schottky rectifier, 1N5825
 L1 = 47- μ H, L39, Renco through hole
 $R_{PULL\ UP}$ = 10k
 C_{DELAY} = 0.1 μ F
 $C_{SD/SS}$ = 0.1 μ F
 Thermalloy heat sink #7020

Figure 32. Typical Through-Hole PCB Layout, Fixed Output (1x Size), Double-Sided

LM2592HV

SNVS075E –MAY 2001–REVISED MAY 2016

www.ti.com

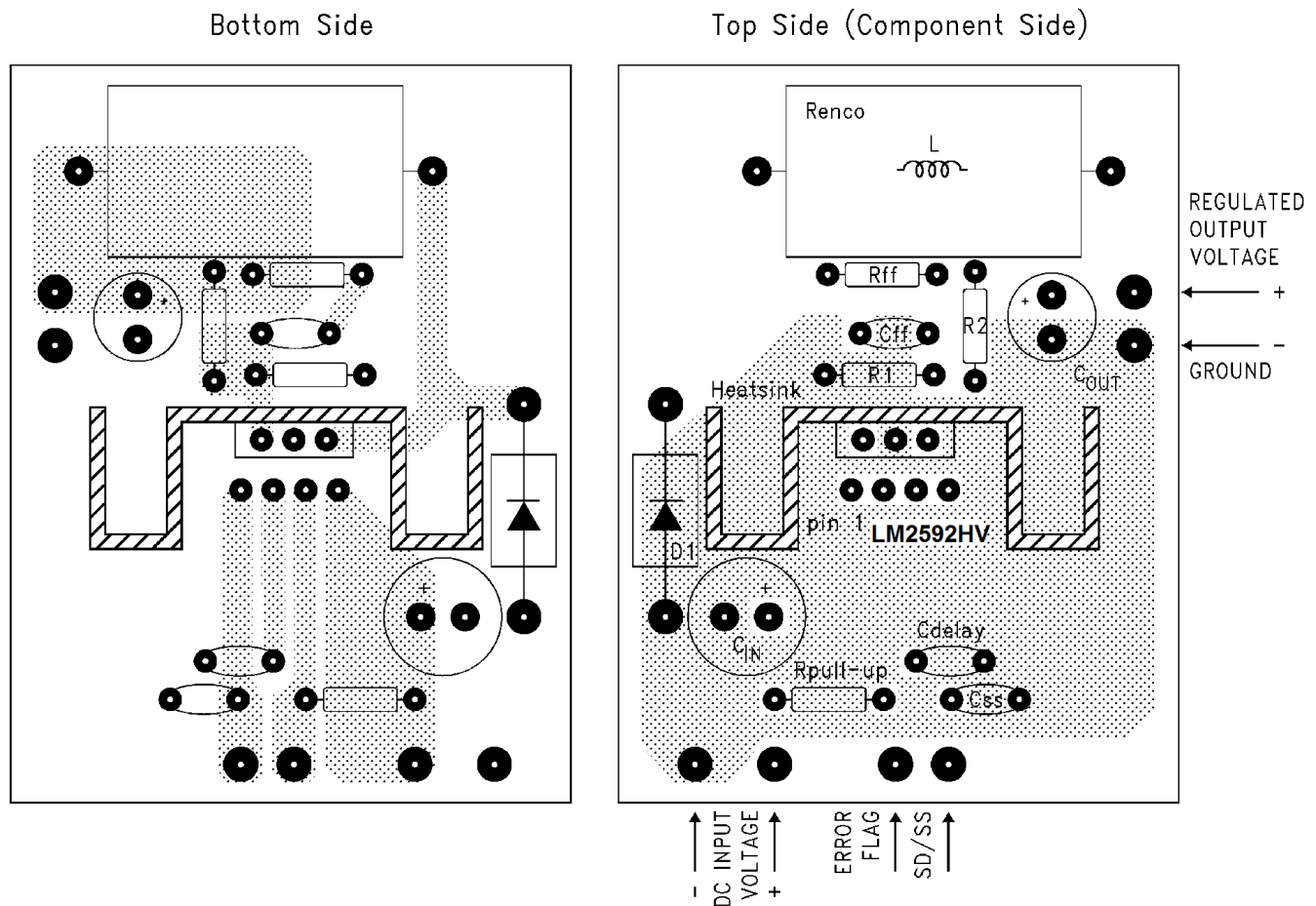
Layout Examples (continued)

C_{IN} = 470- μ F, 50-V, aluminum electrolytic Panasonic, HFQ Series
 C_{OUT} = 220- μ F, 35-V, aluminum electrolytic Panasonic, HFQ Series
 D1 = 5-A, 40-V Schottky Rectifier, 1N5825
 L1 = 47- μ H, L39, Renco, through-hole
 R_1 = 1 k Ω , 1%
 R_2 = Use formula in [Detailed Design Procedure](#)
 R_{FF} = See [Feedforward Capacitor](#)
 $R_{PULL\ UP}$ = 10k
 C_{DELAY} = 0.1 μ F
 $C_{SD/SS}$ = 0.1 μ F
 Thermalloy heat sink #7020

Figure 33. Typical Through-Hole PCB Layout, Adjustable Output (1x Size), Double-Sided

12.3 Thermal Considerations

The LM2592HV is available in two packages, a 5-pin TO-220 (NDH) and a 5-pin surface mount DPAK (KTT).

The TO-220 package needs a heat sink under most conditions. The size of the heat sink depends on the input voltage, the output voltage, the load current, and the ambient temperature. Higher ambient temperatures require more heat sinking.

Thermal Considerations (continued)

The DDPAK surface mount package tab is designed to be soldered to the copper on a printed-circuit board. The copper and the board are the heat sink for this package and the other heat producing components, such as the catch diode and inductor. The PCB copper area that the package is soldered to must be at least 0.4 in², and ideally should have 2 or more square inches of 2 oz. (0.0028 in) copper. Additional copper area improves the thermal characteristics, but with copper areas greater than approximately 6 in², only small improvements in heat dissipation are realized. If further thermal improvements are needed, double sided, multilayer PCB with large copper areas and/or airflow are recommended.

The curves shown in Figure 34 show the LM2592HVS (DDPAK package) junction temperature rise above ambient temperature with a 2-A load for various input and output voltages. This data was taken with the circuit operating as a buck switching regulator with all components mounted on a PCB to simulate the junction temperature under actual operating conditions. This curve can be used for a quick check for the approximate junction temperature for various conditions, but be aware that there are many factors that can affect the junction temperature. When load currents higher than 2 A are used, double-sided or multilayer PCBs with large copper areas or airflow might be needed, especially for high ambient temperatures and high output voltages.

For the best thermal performance, wide copper traces and generous amounts of printed-circuit board copper should be used in the board layout. (One exception to this is the output (switch) pin, which must **not** have large areas of copper.) Large areas of copper provide the best transfer of heat (lower thermal resistance) to the surrounding air, and moving air lowers the thermal resistance even further.

Package thermal resistance and junction temperature rise numbers are all approximate, and there are many factors that will affect these numbers. Some of these factors include board size, shape, thickness, position, location, and even board temperature. Other factors are, trace width, total printed-circuit copper area, copper thickness, single- or double-sided, multilayer board and the amount of solder on the board. The effectiveness of the PCB to dissipate heat also depends on the size, quantity, and spacing of other components on the board, as well as whether the surrounding air is still or moving. Furthermore, some of these components such as the catch diode will add heat to the PCB and the heat can vary as the input voltage changes. For the inductor, depending on the physical size, type of core material and the DC resistance, it could either act as a heat sink taking heat away from the board, or it could add heat to the board.

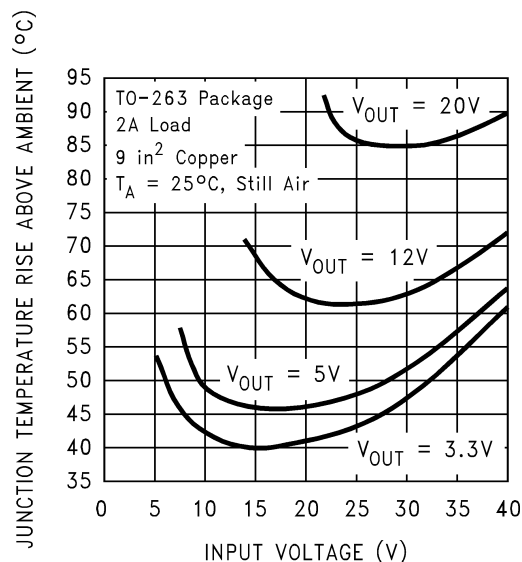

Figure 34. Junction Temperature Rise, DDPAK

LM2592HV

SNVS075E –MAY 2001–REVISED MAY 2016

www.ti.com

13 Device and Documentation Support

13.1 Community Resources

The following links connect to TI community resources. Linked contents are provided "AS IS" by the respective contributors. They do not constitute TI specifications and do not necessarily reflect TI's views; see TI's [Terms of Use](#).

TI E2E™ Online Community *TI's Engineer-to-Engineer (E2E) Community*. Created to foster collaboration among engineers. At e2e.ti.com, you can ask questions, share knowledge, explore ideas and help solve problems with fellow engineers.

Design Support *TI's Design Support* Quickly find helpful E2E forums along with design support tools and contact information for technical support.

13.2 Trademarks

E2E is a trademark of Texas Instruments.

SIMPLE SWITCHER is a registered trademark of Texas Instruments.

All other trademarks are the property of their respective owners.

13.3 Electrostatic Discharge Caution



These devices have limited built-in ESD protection. The leads should be shorted together or the device placed in conductive foam during storage or handling to prevent electrostatic damage to the MOS gates.

13.4 Glossary

[SLYZ022](#) — *TI Glossary*.

This glossary lists and explains terms, acronyms, and definitions.

14 Mechanical, Packaging, and Orderable Information

The following pages include mechanical, packaging, and orderable information. This information is the most current data available for the designated devices. This data is subject to change without notice and revision of this document. For browser-based versions of this data sheet, refer to the left-hand navigation.

PACKAGING INFORMATION

Orderable part number	Status (1)	Material type (2)	Package Pins	Package qty Carrier	RoHS (3)	Lead finish/ Ball material (4)	MSL rating/ Peak reflow (5)	Op temp (°C)	Part marking (6)
LM2592HVS-3.3/NOPB	Active	Production	DDPAK/ TO-263 (KTT) 5	45 TUBE	ROHS Exempt	SN	Level-3-245C-168 HR	-40 to 125	LM2592HVS -3.3 P+
LM2592HVS-3.3/NOPB.B	Active	Production	DDPAK/ TO-263 (KTT) 5	45 TUBE	ROHS Exempt	SN	Level-3-245C-168 HR	-40 to 125	LM2592HVS -3.3 P+
LM2592HVS-5.0/NOPB	Active	Production	DDPAK/ TO-263 (KTT) 5	45 TUBE	ROHS Exempt	SN	Level-3-245C-168 HR	-40 to 125	LM2592HVS -5.0 P+
LM2592HVS-5.0/NOPB.B	Active	Production	DDPAK/ TO-263 (KTT) 5	45 TUBE	ROHS Exempt	SN	Level-3-245C-168 HR	-40 to 125	LM2592HVS -5.0 P+
LM2592HVS-ADJ/NOPB	Active	Production	DDPAK/ TO-263 (KTT) 5	45 TUBE	ROHS Exempt	SN	Level-3-245C-168 HR	-40 to 125	LM2592HVS -ADJ P+
LM2592HVS-ADJ/NOPB.B	Active	Production	DDPAK/ TO-263 (KTT) 5	45 TUBE	ROHS Exempt	SN	Level-3-245C-168 HR	-40 to 125	LM2592HVS -ADJ P+
LM2592HVSX-3.3/NOPB	Active	Production	DDPAK/ TO-263 (KTT) 5	500 LARGE T&R	ROHS Exempt	SN	Level-3-245C-168 HR	-40 to 125	LM2592HVS -3.3 P+
LM2592HVSX-5.0/NOPB	Active	Production	DDPAK/ TO-263 (KTT) 5	500 LARGE T&R	ROHS Exempt	SN	Level-3-245C-168 HR	-40 to 125	LM2592HVS -5.0 P+
LM2592HVSX-ADJ/NOPB	Active	Production	DDPAK/ TO-263 (KTT) 5	500 LARGE T&R	ROHS Exempt	SN	Level-3-245C-168 HR	-40 to 125	LM2592HVS -ADJ P+
LM2592HVT-3.3/NOPB	Active	Production	TO-220 (NDH) 5	45 TUBE	Yes	SN	Level-1-NA-UNLIM	-40 to 125	LM2592HVT -3.3 P+
LM2592HVT-3.3/NOPB.B	Active	Production	TO-220 (NDH) 5	45 TUBE	Yes	SN	Level-1-NA-UNLIM	-40 to 125	LM2592HVT -3.3 P+
LM2592HVT-5.0/NOPB	Active	Production	TO-220 (NDH) 5	45 TUBE	Yes	SN	Level-1-NA-UNLIM	-40 to 125	LM2592HVT -5.0 P+
LM2592HVT-5.0/NOPB.B	Active	Production	TO-220 (NDH) 5	45 TUBE	Yes	SN	Level-1-NA-UNLIM	-40 to 125	LM2592HVT -5.0 P+
LM2592HVT-ADJ/NOPB	Active	Production	TO-220 (NDH) 5	45 TUBE	Yes	SN	Level-1-NA-UNLIM	-40 to 125	LM2592HVT -ADJ P+
LM2592HVT-ADJ/NOPB.B	Active	Production	TO-220 (NDH) 5	45 TUBE	Yes	SN	Level-1-NA-UNLIM	-40 to 125	LM2592HVT -ADJ P+

(1) **Status:** For more details on status, see our [product life cycle](#).

- (2) **Material type:** When designated, preproduction parts are prototypes/experimental devices, and are not yet approved or released for full production. Testing and final process, including without limitation quality assurance, reliability performance testing, and/or process qualification, may not yet be complete, and this item is subject to further changes or possible discontinuation. If available for ordering, purchases will be subject to an additional waiver at checkout, and are intended for early internal evaluation purposes only. These items are sold without warranties of any kind.
- (3) **RoHS values:** Yes, No, RoHS Exempt. See the [TI RoHS Statement](#) for additional information and value definition.
- (4) **Lead finish/Ball material:** Parts may have multiple material finish options. Finish options are separated by a vertical ruled line. Lead finish/Ball material values may wrap to two lines if the finish value exceeds the maximum column width.
- (5) **MSL rating/Peak reflow:** The moisture sensitivity level ratings and peak solder (reflow) temperatures. In the event that a part has multiple moisture sensitivity ratings, only the lowest level per JEDEC standards is shown. Refer to the shipping label for the actual reflow temperature that will be used to mount the part to the printed circuit board.
- (6) **Part marking:** There may be an additional marking, which relates to the logo, the lot trace code information, or the environmental category of the part.

Multiple part markings will be inside parentheses. Only one part marking contained in parentheses and separated by a "~" will appear on a part. If a line is indented then it is a continuation of the previous line and the two combined represent the entire part marking for that device.

Important Information and Disclaimer: The information provided on this page represents TI's knowledge and belief as of the date that it is provided. TI bases its knowledge and belief on information provided by third parties, and makes no representation or warranty as to the accuracy of such information. Efforts are underway to better integrate information from third parties. TI has taken and continues to take reasonable steps to provide representative and accurate information but may not have conducted destructive testing or chemical analysis on incoming materials and chemicals. TI and TI suppliers consider certain information to be proprietary, and thus CAS numbers and other limited information may not be available for release.

In no event shall TI's liability arising out of such information exceed the total purchase price of the TI part(s) at issue in this document sold by TI to Customer on an annual basis.

TAPE AND REEL INFORMATION

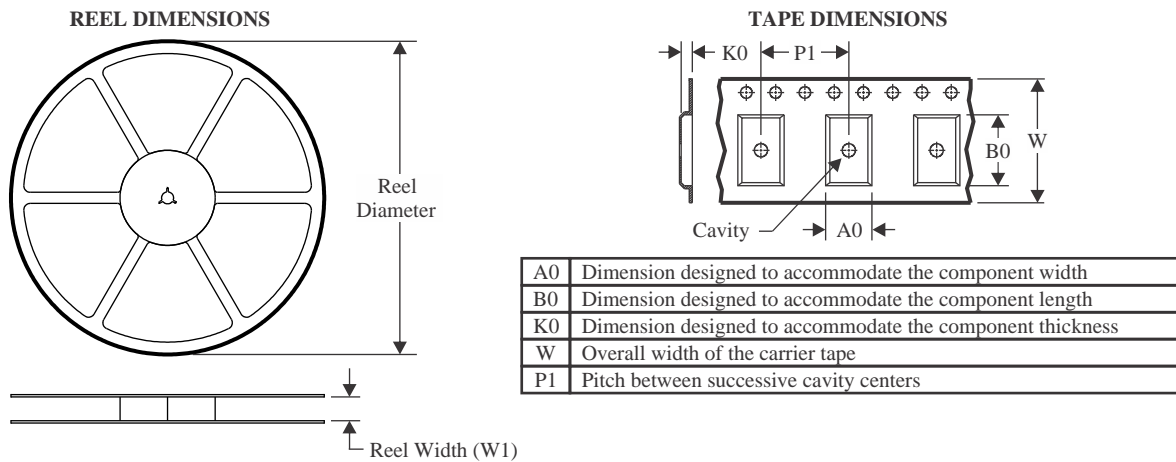

QUADRANT ASSIGNMENTS FOR PIN 1 ORIENTATION IN TAPE

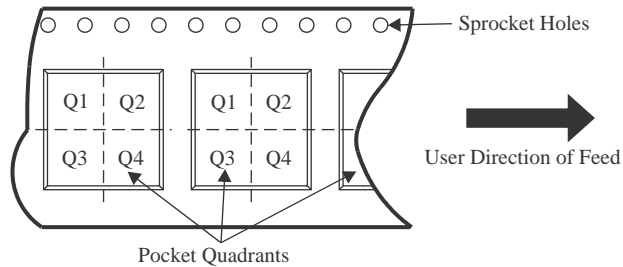

*All dimensions are nominal

Device	Package Type	Package Drawing	Pins	SPQ	Reel Diameter (mm)	Reel Width W1 (mm)	A0 (mm)	B0 (mm)	K0 (mm)	P1 (mm)	W (mm)	Pin1 Quadrant
LM2592HVSX-3.3/NOPB	DDPAK/ TO-263	KTT	5	500	330.0	24.4	10.75	14.85	5.0	16.0	24.0	Q2
LM2592HVSX-5.0/NOPB	DDPAK/ TO-263	KTT	5	500	330.0	24.4	10.75	14.85	5.0	16.0	24.0	Q2
LM2592HVSX-ADJ/NOPB	DDPAK/ TO-263	KTT	5	500	330.0	24.4	10.75	14.85	5.0	16.0	24.0	Q2

TAPE AND REEL BOX DIMENSIONS

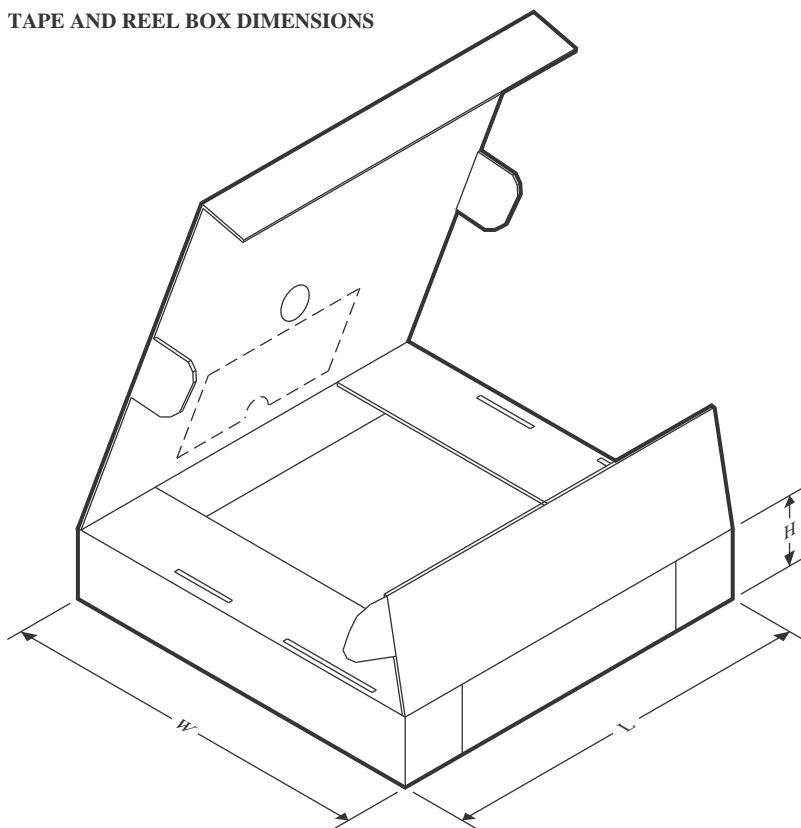

*All dimensions are nominal

Device	Package Type	Package Drawing	Pins	SPQ	Length (mm)	Width (mm)	Height (mm)
LM2592HVSX-3.3/NOPB	DDPAK/TO-263	KTT	5	500	356.0	356.0	45.0
LM2592HVSX-5.0/NOPB	DDPAK/TO-263	KTT	5	500	356.0	356.0	45.0
LM2592HVSX-ADJ/NOPB	DDPAK/TO-263	KTT	5	500	356.0	356.0	45.0

TUBE

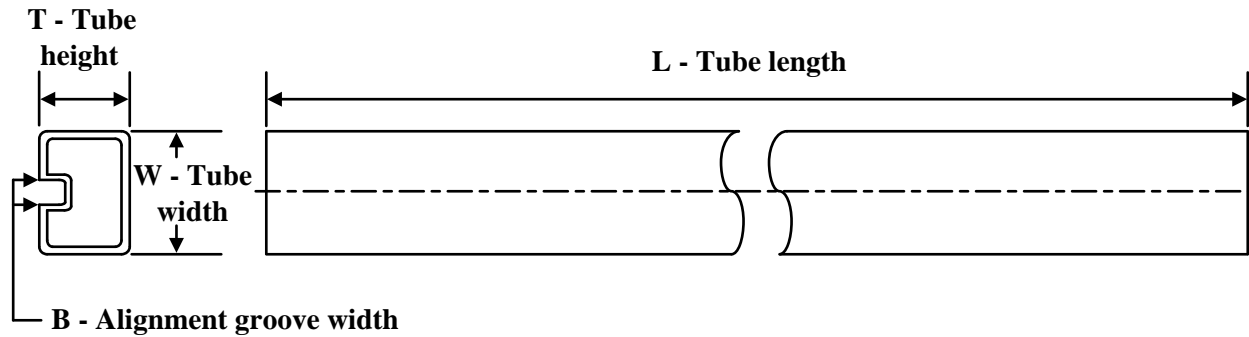

*All dimensions are nominal

Device	Package Name	Package Type	Pins	SPQ	L (mm)	W (mm)	T (μm)	B (mm)
LM2592HVS-3.3/NOPB	KTT	TO-263	5	45	502	25	8204.2	9.19
LM2592HVS-3.3/NOPB.B	KTT	TO-263	5	45	502	25	8204.2	9.19
LM2592HVS-5.0/NOPB	KTT	TO-263	5	45	502	25	8204.2	9.19
LM2592HVS-5.0/NOPB.B	KTT	TO-263	5	45	502	25	8204.2	9.19
LM2592HVS-ADJ/NOPB	KTT	TO-263	5	45	502	25	8204.2	9.19
LM2592HVS-ADJ/NOPB.B	KTT	TO-263	5	45	502	25	8204.2	9.19
LM2592HVT-3.3/NOPB	NDH	TO-220	5	45	502	30	30048.2	10.74
LM2592HVT-3.3/NOPB.B	NDH	TO-220	5	45	502	30	30048.2	10.74
LM2592HVT-5.0/NOPB	NDH	TO-220	5	45	502	30	30048.2	10.74
LM2592HVT-5.0/NOPB.B	NDH	TO-220	5	45	502	30	30048.2	10.74
LM2592HVT-ADJ/NOPB	NDH	TO-220	5	45	502	30	30048.2	10.74
LM2592HVT-ADJ/NOPB.B	NDH	TO-220	5	45	502	30	30048.2	10.74

MECHANICAL DATA

NDH0005D

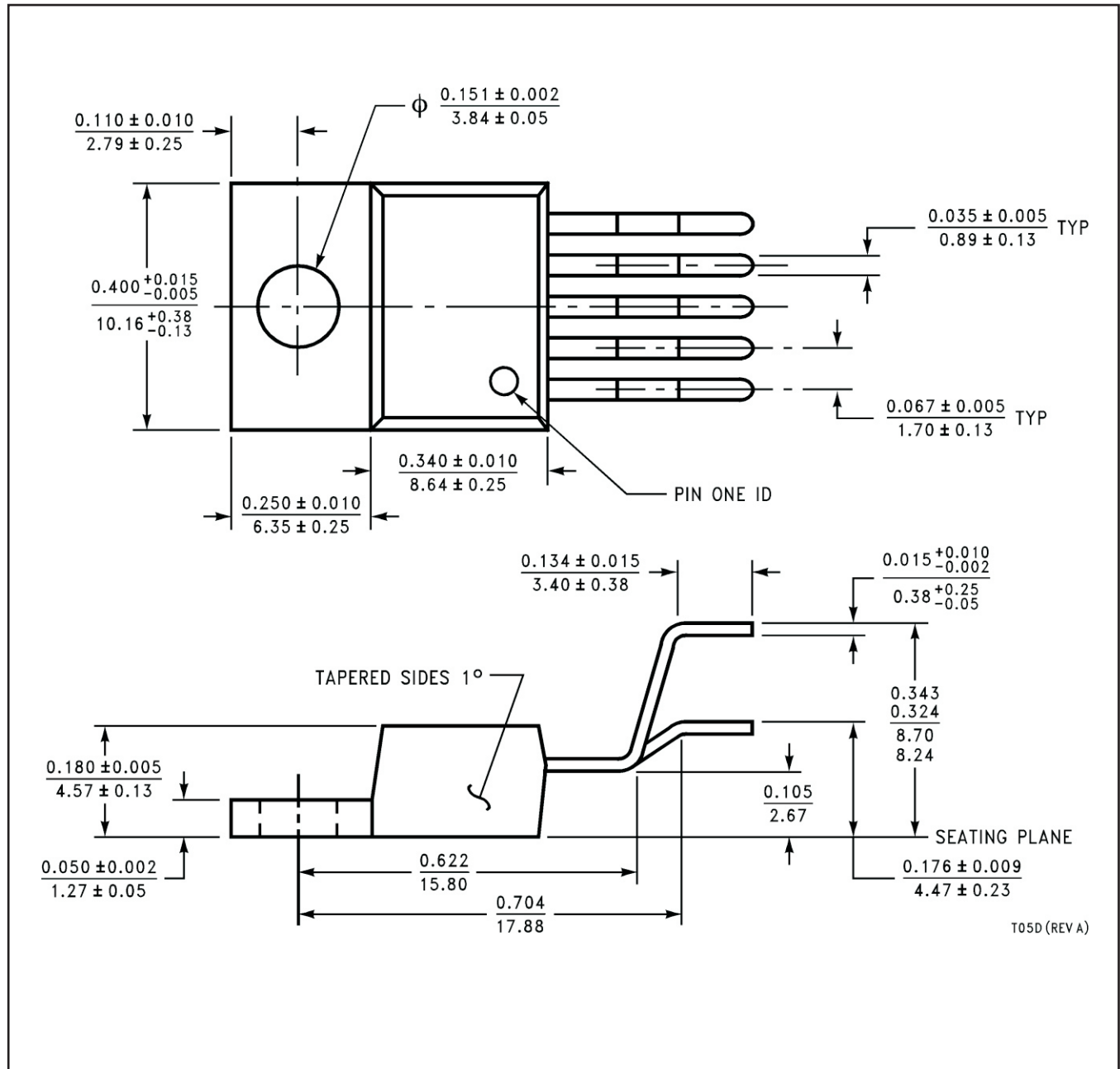

MECHANICAL DATA

KTT0005B

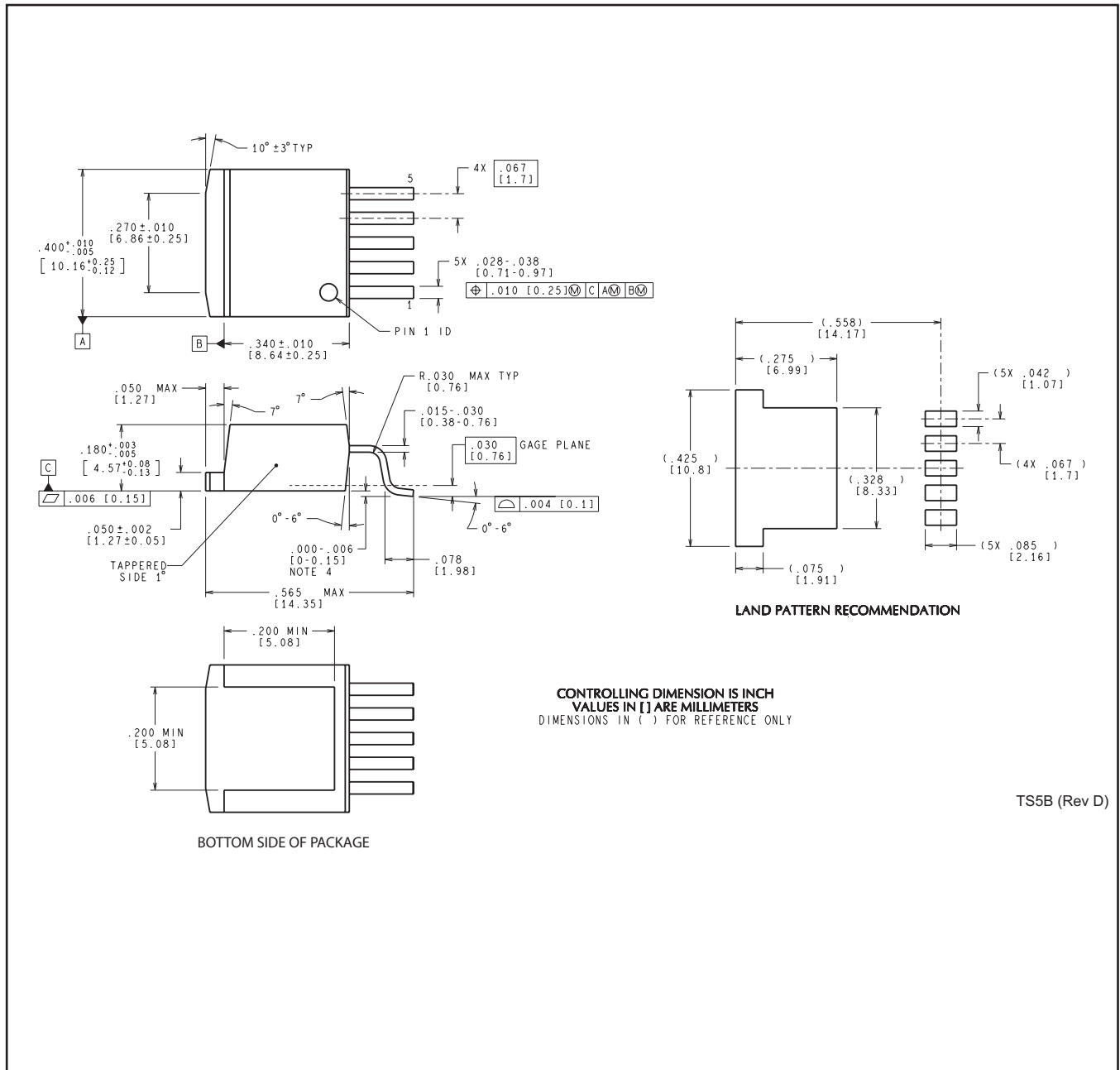

IMPORTANT NOTICE AND DISCLAIMER

TI PROVIDES TECHNICAL AND RELIABILITY DATA (INCLUDING DATASHEETS), DESIGN RESOURCES (INCLUDING REFERENCE DESIGNS), APPLICATION OR OTHER DESIGN ADVICE, WEB TOOLS, SAFETY INFORMATION, AND OTHER RESOURCES "AS IS" AND WITH ALL FAULTS, AND DISCLAIMS ALL WARRANTIES, EXPRESS AND IMPLIED, INCLUDING WITHOUT LIMITATION ANY IMPLIED WARRANTIES OF MERCHANTABILITY, FITNESS FOR A PARTICULAR PURPOSE OR NON-INFRINGEMENT OF THIRD PARTY INTELLECTUAL PROPERTY RIGHTS.

These resources are intended for skilled developers designing with TI products. You are solely responsible for (1) selecting the appropriate TI products for your application, (2) designing, validating and testing your application, and (3) ensuring your application meets applicable standards, and any other safety, security, regulatory or other requirements.

These resources are subject to change without notice. TI grants you permission to use these resources only for development of an application that uses the TI products described in the resource. Other reproduction and display of these resources is prohibited. No license is granted to any other TI intellectual property right or to any third party intellectual property right. TI disclaims responsibility for, and you fully indemnify TI and its representatives against any claims, damages, costs, losses, and liabilities arising out of your use of these resources.

TI's products are provided subject to [TI's Terms of Sale](#), [TI's General Quality Guidelines](#), or other applicable terms available either on [ti.com](#) or provided in conjunction with such TI products. TI's provision of these resources does not expand or otherwise alter TI's applicable warranties or warranty disclaimers for TI products. Unless TI explicitly designates a product as custom or customer-specified, TI products are standard, catalog, general purpose devices.

TI objects to and rejects any additional or different terms you may propose.

Copyright © 2025, Texas Instruments Incorporated

Last updated 10/2025

OUR CERTIFICATE

DiGi provide top-quality products and perfect service for customer worldwide through standardization, technological innovation and continuous improvement. DiGi through third-party certification, we stricly control the quality of products and services. Welcome your RFQ to

Email: Info@DiGi-Electronics.com



Tel: +00 852-30501935

RFQ Email: Info@DiGi-Electronics.com

DiGi is a global authorized distributor of electronic components.