

LM5019SDX/NOPB Datasheet

www.digi-electronics.com

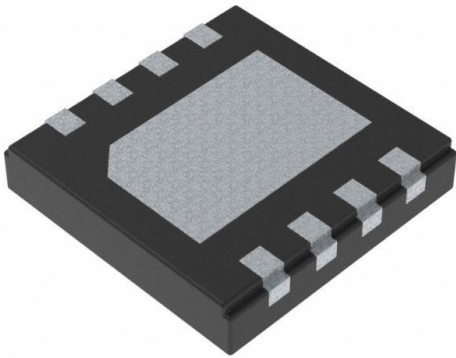

LM5019SDX/NOPB

<https://www.DiGi-Electronics.com>

DiGi Electronics Part Number	LM5019SDX/NOPB-DG
Manufacturer	Texas Instruments
Manufacturer Product Number	LM5019SDX/NOPB
Description	IC REG BUCK ADJ 100MA 8WSON
Detailed Description	Buck Switching Regulator IC Positive Adjustable 1.2 25V 1 Output 100mA 8-WDFN Exposed Pad



Tel: +00 852-30501935

RFQ Email: Info@DiGi-Electronics.com

DiGi is a global authorized distributor of electronic components.

Purchase and inquiry

Manufacturer Product Number:

LM5019SDX/NOPB

Series:

-

Function:

Step-Down

Topology:

Buck

Number of Outputs:

1

Voltage - Input (Max):

100V

Voltage - Output (Max):

90V

Frequency - Switching:

Adj to 1MHz

Operating Temperature:

-40°C ~ 125°C (Tj)

Package / Case:

8-WDFN Exposed Pad

Base Product Number:

LM5019

Manufacturer:

Texas Instruments

Product Status:

Active

Output Configuration:

Positive

Output Type:

Adjustable

Voltage - Input (Min):

7.5V

Voltage - Output (Min/Fixed):

1.225V

Current - Output:

100mA

Synchronous Rectifier:

Yes

Mounting Type:

Surface Mount

Supplier Device Package:

8-WSON (4x4)

Environmental & Export classification

RoHS Status:

ROHS3 Compliant

REACH Status:

REACH Unaffected

HTSUS:

8542.39.0001

Moisture Sensitivity Level (MSL):

1 (Unlimited)

ECCN:

EAR99

LM5019 100-V, 100-mA Constant On-Time Synchronous Buck / Fly-Buck™ Regulator

1 Features

- Wide 7.5-V to 100-V input range
- Integrated 100-mA high-side and low-side switches
- No schottky required
- Constant on-time control
- No loop compensation required
- Ultra-fast transient response
- Nearly constant operating frequency
- Intelligent peak current limit
- Adjustable output voltage from 1.225 V
- Precision 2% feedback reference
- Frequency adjustable to 1 MHz
- Adjustable undervoltage lockout
- Remote shutdown
- Thermal shutdown
- Packages:
 - 8-Pin WSON
 - 8-Pin SO PowerPAD
- Create a custom design using the LM5019 with the [WEBENCH® Power Designer](#)

2 Applications

- [Smart power meters](#)
- [Telecommunication systems](#)
- [Automotive electronics](#)
- [Isolated bias supply \(Fly-Buck™\)](#)

3 Description

The LM5019 is a 100-V, 100-mA synchronous step-down regulator with integrated high-side and low-side MOSFETs. The constant-on-time (COT) control scheme employed in the LM5019 requires no loop compensation, provides excellent transient response, and enables very low step-down ratios. The on-time varies inversely with the input voltage resulting in nearly constant frequency over the input voltage range. A high-voltage start-up regulator provides bias power for internal operation of the IC and for integrated gate drivers.

A peak current limit circuit protects against overload conditions. The undervoltage lockout (UVLO) circuit allows the input undervoltage threshold and hysteresis to be independently programmed. Other protection features include thermal shutdown and bias supply undervoltage lockout.

The LM5019 device is available in WSON-8 and SO PowerPAD-8 plastic packages.

Device Information

PART NUMBER	PACKAGE ⁽¹⁾	BODY SIZE (NOM)
LM5019	SO PowerPAD (8)	4.89 mm × 3.90 mm
	WSON (8)	4.00 mm × 4.00 mm

(1) For all available packages, see the orderable addendum at the end of the data sheet.



Typical Application

LM5019

SNVS788H – JANUARY 2012 – REVISED AUGUST 2021

Table of Contents

1 Features	1	8 Application and Implementation	15
2 Applications	1	8.1 Application Information.....	15
3 Description	1	8.2 Typical Applications.....	15
4 Revision History	2	9 Power Supply Recommendations	25
5 Pin Configuration and Functions	3	10 Layout	26
6 Specifications	4	10.1 Layout Guidelines.....	26
6.1 Absolute Maximum Ratings.....	4	10.2 Layout Example.....	26
6.2 ESD Ratings.....	4	11 Device and Documentation Support	27
6.3 Recommended Operating Conditions.....	4	11.1 Device Support.....	27
6.4 Thermal Information.....	4	11.2 Documentation Support.....	27
6.5 Electrical Characteristics.....	5	11.3 Receiving Notification of Documentation Updates..	27
6.6 Switching Characteristics.....	6	11.4 Support Resources.....	27
6.7 Typical Characteristics.....	7	11.5 Trademarks.....	27
7 Detailed Description	9	11.6 Electrostatic Discharge Caution.....	28
7.1 Overview.....	9	11.7 Glossary.....	28
7.2 Functional Block Diagram.....	9	12 Mechanical, Packaging, and Orderable Information	28
7.3 Feature Description.....	9		
7.4 Device Functional Modes.....	14		

4 Revision History

Changes from Revision G (November 2017) to Revision H (August 2021) Page

- Added "Synchronous Fly-Buck" to the title 1
- Updated the numbering format for tables, figures, and cross-references throughout the document. 1

Changes from Revision F (December 2014) to Revision G (November 2017) Page

- Added WEBENCH links to the data sheet..... 1
- Deleted lead temperature from the *Absolute Maximum Ratings* table 4
- Changed 14 V to 13 V in *V_{CC} Regulator* section..... 10
- Changed 8 to 4 on equation in *Input Capacitor* section 18
- Changed 0.06 μF to 0.12 μF in *Input Capacitor* section..... 18

5 Pin Configuration and Functions

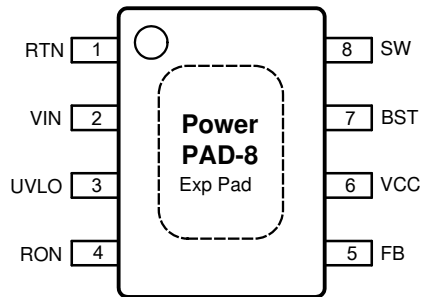

Connect Exposed Pad to RTN

Figure 5-1. DDA Package 8-Pin SO PowerPAD Top View

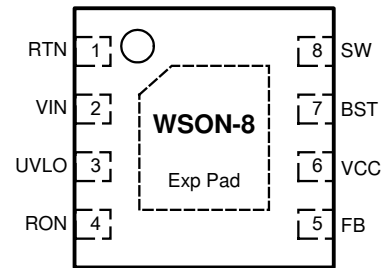

Connect Exposed Pad to RTN

Figure 5-2. NGU Package 8-Pin WSON Top View

Table 5-1. Pin Functions

PIN		I/O	DESCRIPTION	APPLICATION INFORMATION
NO.	NAME			
1	RTN	—	Ground	Ground connection of the integrated circuit
2	VIN	I	Input Voltage	Operating input range is 7.5 V to 100 V.
3	UVLO	I	Input Pin of Undervoltage Comparator	Resistor divider from V_{IN} to UVLO to GND programs the undervoltage detection threshold. An internal current source is enabled when UVLO is above 1.225 V to provide hysteresis. When UVLO pin is pulled below 0.66 V externally, the parts goes in shutdown mode.
4	RON	I	On-Time Control	A resistor between this pin and V_{IN} sets the switch on-time as a function of V_{IN} . Minimum recommended on-time is 100 ns at max input voltage.
5	FB	I	Feedback	This pin is connected to the inverting input of the internal regulation comparator. The regulation level is 1.225 V.
6	VCC	O	Output From the Internal High Voltage Series Pass Regulator. Regulated at 7.6 V	The internal VCC regulator provides bias supply for the gate drivers and other internal circuitry. A 1.0- μ F decoupling capacitor is recommended.
7	BST	I	Bootstrap Capacitor	An external capacitor is required between the BST and SW pins (0.01- μ F ceramic). The BST pin capacitor is charged by the VCC regulator through an internal diode when the SW pin is low.
8	SW	O	Switching Node	Power switching node. Connect to the output inductor and bootstrap capacitor.
—	EP	—	Exposed Pad	Exposed pad must be connected to RTN pin. Connect to system ground plane on application board for reduced thermal resistance.

LM5019

SNVS788H – JANUARY 2012 – REVISED AUGUST 2021

6 Specifications**6.1 Absolute Maximum Ratings**

	MIN ⁽¹⁾	MAX	UNIT
V _{IN} , UVLO to RTN	-0.3	100	V
SW to RTN	-1.5	V _{IN} + 0.3	V
SW to RTN (100-ns transient)	-5	V _{IN} + 0.3	V
BST to VCC		100	V
BST to SW		13	V
RON to RTN	-0.3	100	V
VCC to RTN	-0.3	13	V
FB to RTN	-0.3	5	V
Maximum junction temperature ⁽²⁾		150	°C
Storage temperature, T _{stg}	-55	150	°C

- (1) *Absolute Maximum Ratings* are limits beyond which damage to the device may occur. [Section 6.3](#) are conditions under which operation of the device is intended to be functional. For verified specifications and test conditions, see [Section 6.5](#). The RTN pin is the GND reference electrically connected to the substrate.
- (2) High junction temperatures degrade operating lifetimes. Operating lifetime is derated for junction temperatures greater than 125°C.

6.2 ESD Ratings

	VALUE	UNIT
V _(ESD) Electrostatic discharge	Human-body model (HBM), per ANSI/ESDA/JEDEC JS-001 ⁽¹⁾	±2000
	Charged-device model (CDM), per JEDEC specification JESD22-C101 ⁽²⁾	±750

- (1) JEDEC document JEP155 states that 500-V HBM allows safe manufacturing with a standard ESD control process.
- (2) JEDEC document JEP157 states that 250-V CDM allows safe manufacturing with a standard ESD control process.

6.3 Recommended Operating Conditionsover operating free-air temperature range (unless otherwise noted)⁽¹⁾

	MIN	MAX	UNIT
V _{IN} voltage	7.5	100	V
Operating junction temperature ⁽²⁾	-40	125	°C

- (1) *Recommended Operating Conditions* are conditions under the device is intended to be functional. For specifications and test conditions, see [Section 6.5](#).
- (2) High junction temperatures degrade operating lifetimes. Operating lifetime is de-rated for junction temperatures greater than 125°C.

6.4 Thermal Information

THERMAL METRIC ⁽¹⁾	LM5019		UNIT
	NGU (WSON)	DDA (SO PowerPAD)	
	8 PINS	8 PINS	
R _{θJA} Junction-to-ambient thermal resistance	41.3	41.1	°C/W
R _{θJCbot} Junction-to-case (bottom) thermal resistance	3.2	2.4	°C/W
Ψ _{JB} Junction-to-board thermal characteristic parameter	19.2	24.4	°C/W
R _{θJB} Junction-to-board thermal resistance	19.1	30.6	°C/W
R _{θJCTop} Junction-to-case (top) thermal resistance	34.7	37.3	°C/W
Ψ _{JT} Junction-to-top thermal characteristic parameter	0.3	6.7	°C/W

- (1) For more information about traditional and new thermal metrics, see the [IC Package Thermal Metrics](#) application report (SPRA953).

6.5 Electrical Characteristics

Typical values correspond to $T_J = 25^\circ\text{C}$. Minimum and maximum limits apply over -40°C to 125°C junction temperature range unless otherwise stated. $V_{IN} = 48\text{ V}$ unless stated otherwise. See⁽²⁾.

PARAMETER	TEST CONDITIONS	MIN	TYP	MAX	UNIT
V_{CC} SUPPLY					
V _{CC} Reg V _{CC} Regulator Output	$V_{IN} = 48\text{ V}$, $I_{CC} = 20\text{ mA}$	6.25	7.6	8.55	V
V _{CC} Current Limit	$V_{IN} = 48\text{ V}$ ⁽¹⁾	26			mA
V _{CC} Undervoltage Lockout Voltage (V _{CC} Increasing)		4.15	4.5	4.9	V
V _{CC} Undervoltage Hysteresis			300		mV
V _{CC} Drop Out Voltage	$V_{IN} = 9\text{ V}$, $I_{CC} = 20\text{ mA}$		2.3		V
I _{IN} Operating Current	Non-Switching, FB = 3 V		1.75		mA
I _{IN} Shutdown Current	UVLO = 0 V		50	225	μA
SWITCH CHARACTERISTICS					
Buck Switch R _{DS(ON)}	$I_{TEST} = 200\text{ mA}$, BST-SW = 7 V		0.8	1.8	Ω
Synchronous R _{DS(ON)}	$I_{TEST} = 200\text{ mA}$		0.45	1	Ω
Gate Drive UVLO	$V_{BST} - V_{SW}$ Rising	2.4	3	3.6	V
Gate Drive UVLO Hysteresis			260		mV
CURRENT LIMIT					
Current Limit Threshold	$-40^\circ\text{C} \leq T_J \leq 125^\circ\text{C}$	150	240	300	mA
Current Limit Response Time	Time to Switch Off		150		ns
Off-Time Generator (Test 1)	FB = 0.1 V, $V_{IN} = 48\text{ V}$		12		μs
Off-Time Generator (Test 2)	FB = 1 V, $V_{IN} = 48\text{ V}$		2.5		μs
REGULATION AND OVERVOLTAGE COMPARATORS					
FB Regulation Level	Internal Reference Trip Point for Switch ON	1.2	1.225	1.25	V
FB Overvoltage Threshold	Trip Point for Switch OFF		1.62		V
FB Bias Current			60		nA
UNDERVOLTAGE SENSING FUNCTION					
UV Threshold	UV Rising	1.19	1.225	1.26	V
UV Hysteresis Input Current	UV = 2.5 V	-10	-20	-29	μA
Remote Shutdown Threshold	Voltage at UVLO Falling	0.32	0.66		V
Remote Shutdown Hysteresis			110		mV
THERMAL SHUTDOWN					
T _{sd} Thermal Shutdown Temperature			165		°C
Thermal Shutdown Hysteresis			20		°C

- (1) V_{CC} provides self bias for the internal gate drive and control circuits. Device thermal limitations limit external loading.
 (2) All hot and cold limits are specified by correlating the electrical characteristics to process and temperature variations and applying statistical process control.

LM5019

SNVS788H – JANUARY 2012 – REVISED AUGUST 2021

6.6 Switching Characteristics

Typical values correspond to $T_J = 25^\circ\text{C}$. Minimum and maximum limits apply over -40°C to 125°C junction temperature range unless otherwise stated. $V_{IN} = 48\text{ V}$ unless stated otherwise. See⁽¹⁾.

		MIN	TYP	MAX	UNIT
ON-TIME GENERATOR					
T_{ON} Test 1	$V_{IN} = 32\text{ V}, R_{ON} = 100\text{ k}\Omega$	270	350	460	ns
T_{ON} Test 2	$V_{IN} = 48\text{ V}, R_{ON} = 100\text{ k}\Omega$	188	250	336	ns
T_{ON} Test 3	$V_{IN} = 75\text{ V}, R_{ON} = 100\text{ k}\Omega$	250	370	500	ns
T_{ON} Test 4	$V_{IN} = 10\text{ V}, R_{ON} = 250\text{ k}\Omega$	1880	3200	4425	ns
MINIMUM OFF-TIME					
Minimum Off-Timer	$FB = 0\text{ V}$		144		ns

- (1) All hot and cold limits are specified by correlating the electrical characteristics to process and temperature variations and applying statistical process control.

6.7 Typical Characteristics

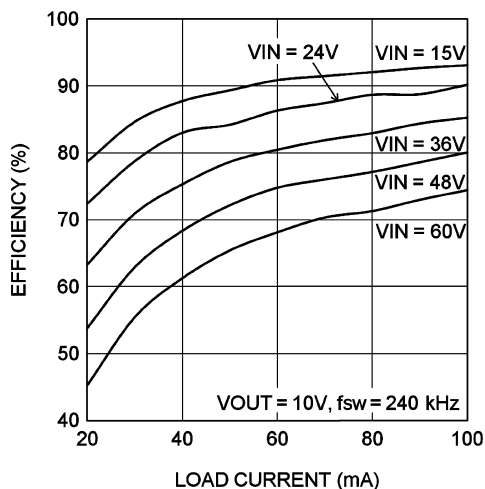

Figure 6-1. Efficiency at 240 kHz, 10 V

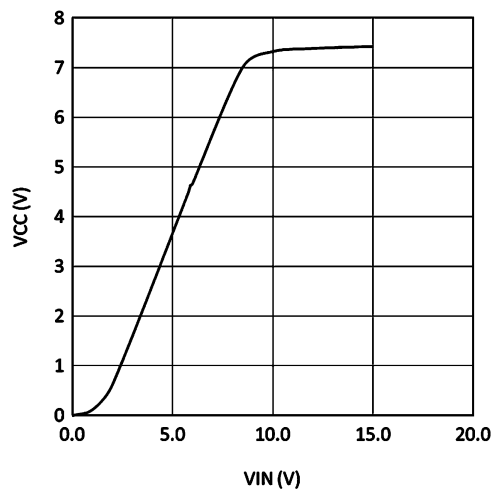

Figure 6-2. V_{CC} versus V_{IN}

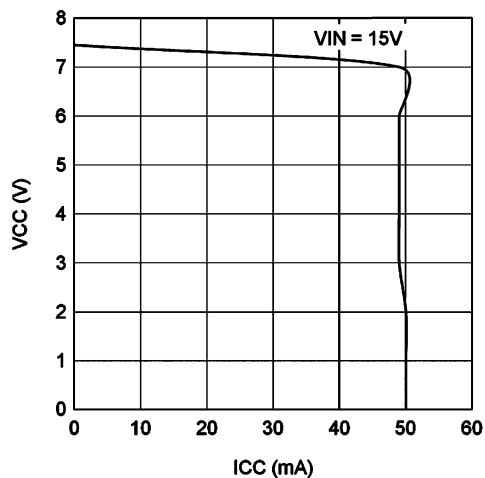

Figure 6-3. V_{CC} versus I_{CC}

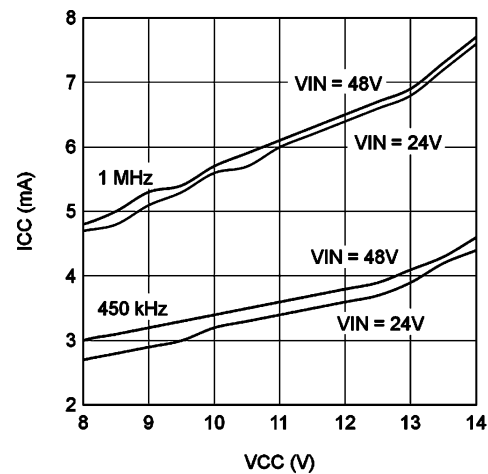

Figure 6-4. I_{CC} versus External V_{CC}

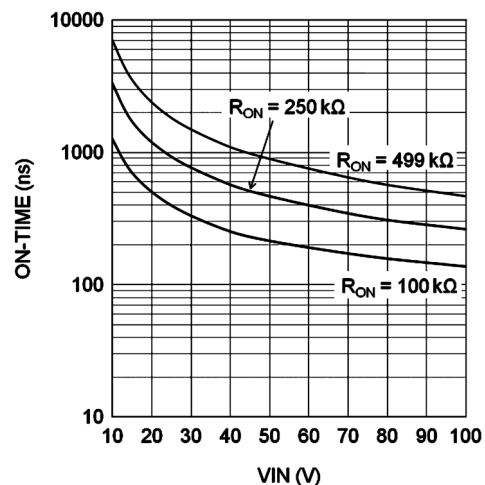

Figure 6-5. T_{ON} versus V_{IN} and R_{ON}

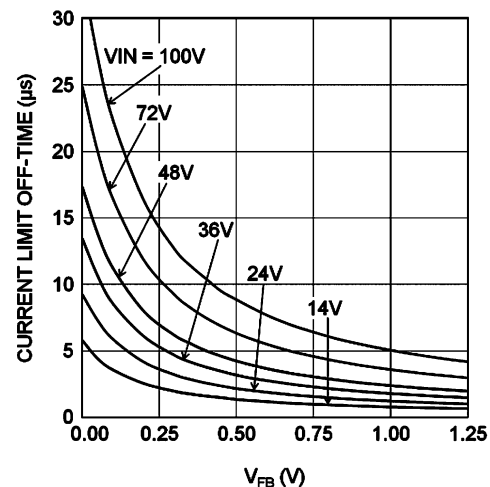

Figure 6-6. T_{OFF} (I_{LIM}) versus V_{FB} and V_{IN}

LM5019

SNVS788H – JANUARY 2012 – REVISED AUGUST 2021

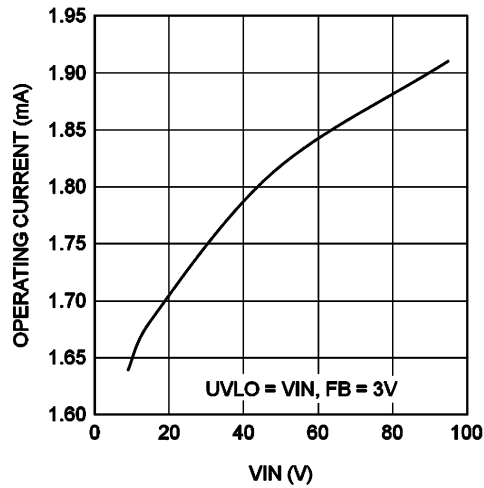

Figure 6-7. I_{IN} versus V_{IN} (Operating, Non-Switching)

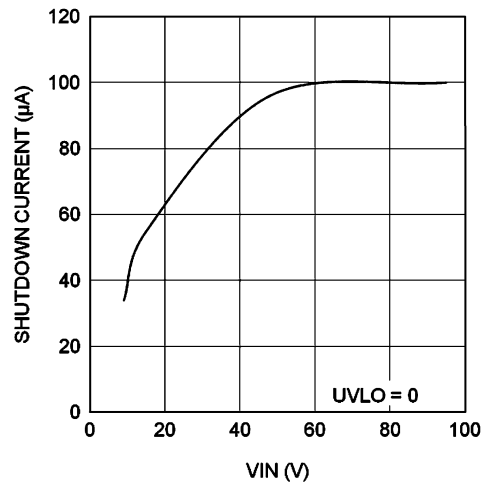

Figure 6-8. I_{IN} versus V_{IN} (Shutdown)

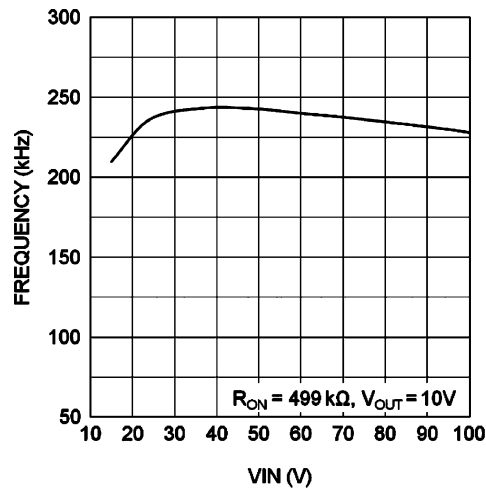

Figure 6-9. Switching Frequency versus V_{IN}

7 Detailed Description

7.1 Overview

The LM5019 step-down switching regulator features all the functions needed to implement a low-cost, efficient, buck converter capable of supplying up to 100 mA to the load. This high-voltage regulator contains 100 V, N-channel buck and synchronous switches, is easy to implement, and is provided in thermally enhanced SO PowerPAD-8 and WSON-8 packages. The regulator operation is based on a constant on-time control scheme using an on-time inversely proportional to V_{IN} . This control scheme does not require loop compensation. The current limit is implemented with a forced off-time inversely proportional to V_{OUT} . This scheme ensures short circuit protection while providing minimum foldback.

The LM5019 can be applied in numerous applications to efficiently regulate down higher voltages. This regulator is well suited for 48-V telecom and automotive power bus ranges. Protection features include: thermal shutdown, undervoltage lockout, minimum forced off-time, and an intelligent current limit.

7.2 Functional Block Diagram

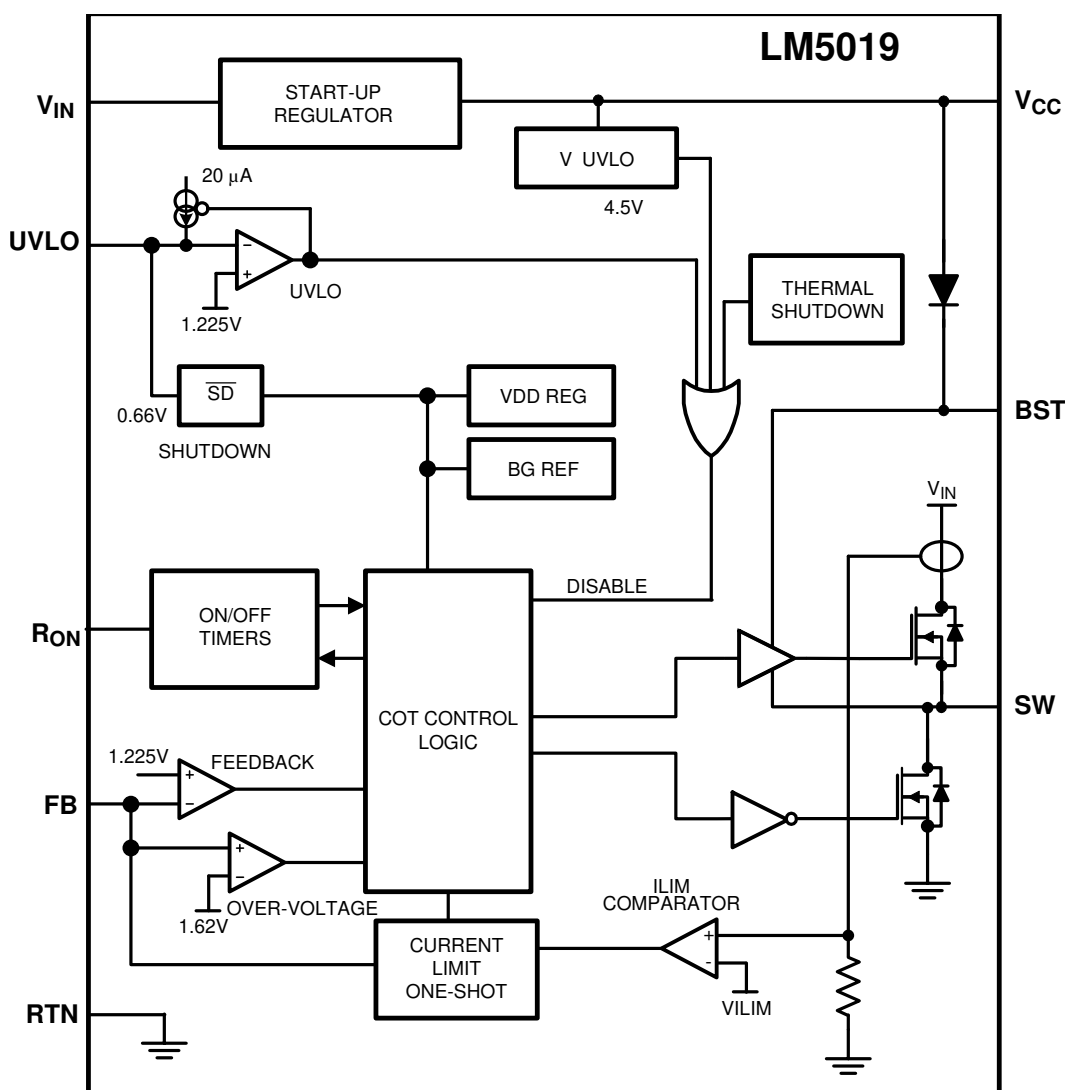

7.3 Feature Description

7.3.1 Control Overview

The LM5019 buck regulator employs a control principle based on a comparator and a one-shot on-timer, with the output voltage feedback (FB) compared to an internal reference (1.225 V). If the FB voltage is below the

LM5019

SNVS788H – JANUARY 2012 – REVISED AUGUST 2021

reference the internal buck switch is turned on for the one-shot timer period, which is a function of the input voltage and the programming resistor (R_{ON}). Following the on-time, the switch remains off until the FB voltage falls below the reference, but never before the minimum off-time forced by the minimum off-time one-shot timer. When the FB pin voltage falls below the reference and the minimum off-time one-shot period expires, the buck switch is turned on for another on-time one-shot period. This will continue until regulation is achieved and the FB voltage is approximately equal to 1.225 V (typ).

In a synchronous buck converter, the low-side (sync) FET is 'on' when the high-side (buck) FET is 'off'. The inductor current ramps up when the high side switch is 'on' and ramps down when the high side switch is 'off'. There is no diode emulation feature in this IC, therefore, the inductor current can ramp in the negative direction at light load. This causes the converter to operate in continuous conduction mode (CCM) regardless of the output loading. The operating frequency remains relatively constant with load and line variations. The operating frequency can be calculated as shown in [Equation 1](#).

$$f_{SW} = \frac{V_{OUT1}}{K \times R_{ON}} \quad (1)$$

where

- $K = 9 \times 10^{-11}$

The output voltage (V_{OUT}) is set by two external resistors (R_{FB1} and R_{FB2}). The regulated output voltage is calculated as shown in [Equation 2](#).

$$\frac{R_{FB2}}{R_{FB1}} = \frac{V_{OUT} - 1.225V}{1.225V} \quad (2)$$

This regulator regulates the output voltage based on ripple voltage at the feedback input, requiring a minimum amount of ESR for the output capacitor (C_{OUT}). A minimum of 25 mV of ripple voltage at the feedback pin (FB) is required for the LM5019. In cases where the capacitor ESR is too small, additional series resistance can be required (R_C in [Figure 7-1](#)).

For applications where lower output voltage ripple is required, the output can be taken directly from a low ESR output capacitor, as shown in [Figure 7-1](#). However, R_C slightly degrades the load regulation.

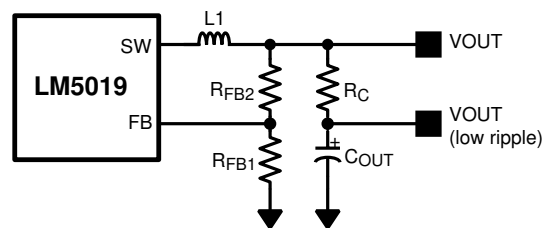

Figure 7-1. Low Ripple Output Configuration

7.3.2 V_{CC} Regulator

The LM5019 contains an internal high-voltage linear regulator with a nominal output of 7.6 V. The input pin (V_{IN}) can be connected directly to the line voltages up to 100 V. The V_{CC} regulator is internally current limited to 30 mA. The regulator sources current into the external capacitor at V_{CC} . This regulator supplies current to internal circuit blocks including the synchronous MOSFET driver and the logic circuits. When the voltage on the V_{CC} pin reaches the undervoltage lockout threshold of 4.5 V, the IC is enabled.

The V_{CC} regulator contains an internal diode connection to the BST pin to replenish the charge in the gate drive boot capacitor when SW pin is low.

At high input voltages, the power dissipated in the high voltage regulator is significant and can limit the overall achievable output power. As an example, with the input at 48 V and switching at high frequency, the V_{CC} regulator can supply up to 7 mA of current resulting in $48 V \times 7 mA = 336 mW$ of power dissipation. If the V_{CC}

voltage is driven externally by an alternate voltage source, between 8.55 V and 13 V, the internal regulator is disabled. This reduces the power dissipation in the IC.

7.3.3 Regulation Comparator

The feedback voltage at FB is compared to an internal 1.225-V reference. In normal operation, when the output voltage is in regulation, an on-time period is initiated when the voltage at FB falls below 1.225 V. The high-side switch stays on for the on-time, causing the FB voltage to rise above 1.225 V. After the on-time period, the high-side switch stays off until the FB voltage again falls below 1.225 V. During start-up, the FB voltage is below 1.225 V at the end of each on-time, causing the high-side switch to turn on immediately after the minimum forced off-time of 144 ns. The high-side switch can be turned off before the on-time is over if the peak current in the inductor reaches the current limit threshold.

7.3.4 Overvoltage Comparator

The feedback voltage at FB is compared to an internal 1.62-V reference. If the voltage at FB rises above 1.62 V, the on-time pulse is immediately terminated. This condition can occur if the input voltage, the output load, of both, changes suddenly. The high-side switch does not turn on again until the voltage at FB falls below 1.225 V.

7.3.5 On-Time Generator

The on-time for the LM5019 is determined by the R_{ON} resistor, and is inversely proportional to the input voltage (V_{IN}), resulting in a nearly constant frequency as V_{IN} is varied over its range. The on-time equation for the LM5019 is shown in [Equation 3](#).

$$T_{ON} = \frac{10^{-10} \times R_{ON}}{V_{IN}} \quad (3)$$

See [Figure 6-5](#). R_{ON} must be selected for a minimum on-time (at maximum V_{IN}) greater than 100 ns, for proper operation. This requirement limits the maximum switching frequency for high V_{IN} .

7.3.6 Current Limit

The LM5019 contains an intelligent current limit off-timer. If the current in the buck switch exceeds 240 mA, the present cycle is immediately terminated, and a non-resettable off-timer is initiated. The length of off-time is controlled by the FB voltage and the input voltage V_{IN} . As an example, when $FB = 0$ V and $V_{IN} = 48$ V, the maximum off-time is set to 16 μ s. This condition occurs when the output is shorted, and during the initial part of start-up. This amount of time ensures safe short circuit operation up to the maximum input voltage of 100 V.

In cases of overload where the FB voltage is above zero volts (not a short circuit), the current limit off-time is reduced. Reducing the off-time during less severe overloads reduces the amount of foldback, recovery time, and start-up time. The off-time is calculated from [Equation 4](#):

$$T_{OFF(ILIM)} = \frac{0.07 \times V_{IN}}{V_{FB} + 0.2 \text{ V}} \mu\text{s} \quad (4)$$

The current limit protection feature is peak limited. The maximum average output will be less than the peak.

7.3.7 N-Channel Buck Switch and Driver

The LM5019 integrates an N-Channel Buck switch and associated floating high voltage gate driver. The gate driver circuit works in conjunction with an external bootstrap capacitor and an internal high voltage diode. A 0.01- μ F ceramic capacitor connected between the BST pin and the SW pin provides the voltage to the driver during the on-time. During each off-time, the SW pin is at approximately 0 V, and the bootstrap capacitor charges from V_{CC} through the internal diode. The minimum off-timer, set to 144 ns, ensures a minimum time each cycle to recharge the bootstrap capacitor.

7.3.8 Synchronous Rectifier

The LM5019 provides an internal synchronous N-Channel MOSFET rectifier. This MOSFET provides a path for the inductor current to flow when the high-side MOSFET is turned off.

LM5019

SNVS788H – JANUARY 2012 – REVISED AUGUST 2021

The synchronous rectifier has no diode emulation mode, and is designed to keep the regulator in continuous conduction mode even during light loads, which would otherwise result in discontinuous operation.

7.3.9 Undervoltage Detector

The LM5019 contains a dual-level Undervoltage Lockout (UVLO) circuit. When the UVLO pin voltage is below 0.66 V, the controller is in a low current shutdown mode. When the UVLO pin voltage is greater than 0.66 V but less than 1.225 V, the controller is in standby mode. In standby mode, the V_{CC} bias regulator is active while the regulator output is disabled. When the V_{CC} pin exceeds the V_{CC} undervoltage threshold and the UVLO pin voltage is greater than 1.225 V, normal operation begins. An external set-point voltage divider from V_{IN} to GND can be used to set the minimum operating voltage of the regulator.

UVLO hysteresis is accomplished with an internal 20- μ A current source that is switched on or off into the impedance of the set-point divider. When the UVLO threshold is exceeded, the current source is activated to quickly raise the voltage at the UVLO pin. The hysteresis is equal to the value of this current times the resistance R_{UV2} .

If the UVLO pin is wired directly to the V_{IN} pin, the regulator begins operation once the V_{CC} undervoltage is satisfied.

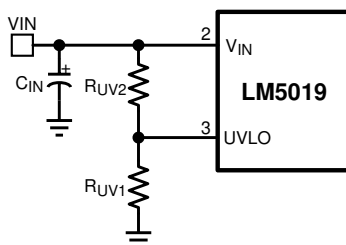
**Figure 7-2. UVLO Resistor Setting****7.3.10 Thermal Protection**

The LM5019 must be operated so the junction temperature does not exceed 150°C during normal operation. An internal Thermal Shutdown circuit is provided to protect the LM5019 in the event of a higher than normal junction temperature. When activated, typically at 165°C, the controller is forced into a low power reset state, disabling the buck switch and the V_{CC} regulator. This feature prevents catastrophic failures from accidental device overheating. When the junction temperature reduces below 145°C (typical hysteresis = 20°C), the V_{CC} regulator is enabled, and normal operation is resumed.

7.3.11 Ripple Configuration

The LM5019 uses Constant-On-Time (COT) control scheme, in which the on-time is terminated by an on-timer, and the off-time is terminated by the feedback voltage (V_{FB}) falling below the reference voltage (V_{REF}). Therefore, for stable operation, the feedback voltage must decrease monotonically, in phase with the inductor current during the off-time. Furthermore, this change in feedback voltage (V_{FB}) during off-time must be large enough to suppress any noise component present at the feedback node.

[Ripple Configuration](#) shows three different methods for generating appropriate voltage ripple at the feedback node. Type 1 and Type 2 ripple circuits couple the ripple at the output of the converter to the feedback node (FB). The output voltage ripple has two components:

1. Capacitive ripple caused by the inductor current ripple charging/discharging the output capacitor.
2. Resistive ripple caused by the inductor current ripple flowing through the ESR of the output capacitor.

The capacitive ripple is not in phase with the inductor current. As a result, the capacitive ripple does not decrease monotonically during the off-time. The resistive ripple is in phase with the inductor current and decreases monotonically during the off-time. The resistive ripple must exceed the capacitive ripple at the output node (V_{OUT}) for stable operation. If this condition is not satisfied unstable switching behavior is observed in COT converters, with multiple on-time bursts in close succession followed by a long off-time.

Type 3 ripple method uses R_r and C_r and the switch node (SW) voltage to generate a triangular ramp. This triangular ramp is ac coupled using C_{ac} to the feedback node (FB). Since this circuit does not use the output voltage ripple, it is ideally suited for applications where low output voltage ripple is required. See the [AN-1481 Controlling Output Ripple and Achieving ESR Independence in Constant On-Time \(COT\) Regulator Designs Application Report](#) (SNVA166) for more details for each ripple generation method.

Ripple Configuration

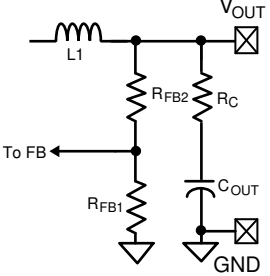
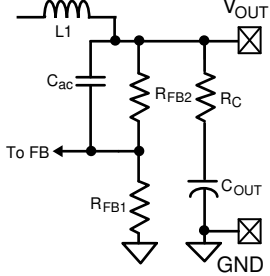
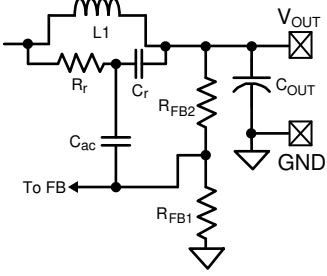
TYPE 1 LOWEST COST CONFIGURATION	TYPE 2 REDUCED RIPPLE CONFIGURATION	TYPE 3 MINIMUM RIPPLE CONFIGURATION
		
$R_C \geq \frac{25 \text{ mV}}{\Delta I_{L(\text{MIN})}} \times \frac{V_{\text{OUT}}}{V_{\text{REF}}}$	$C \geq \frac{5}{f_{\text{sw}} (R_{\text{FB2}} R_{\text{FB1}})}$ $R_C \geq \frac{25 \text{ mV}}{\Delta I_{L(\text{MIN})}}$	$C_r = 3300 \text{ pF}$ $C_{ac} = 100 \text{ nF}$ $R_r C_r \leq \frac{(V_{\text{IN}(\text{MIN})} - V_{\text{OUT}}) \times T_{\text{ON}}}{25 \text{ mV}}$

7.3.12 Soft Start

A soft-start feature can be implemented with the LM5019 using an external circuit. As shown in [Figure 7-3](#), the soft-start circuit consists of one capacitor, C_1 , two resistors, R_1 and R_2 , and a diode, D . During the initial start-up, the VCC voltage is established prior to the V_{OUT} voltage. Capacitor C_1 is discharged and D is thereby forward biased. The FB voltage exceeds the reference voltage (1.225 V) and switching is therefore disabled. As capacitor C_1 charges, the voltage at node B gradually decreases and switching commences. V_{OUT} gradually rises to maintain the FB voltage at the reference voltage. Once the voltage at node B is less than a diode drop above the FB voltage, the soft-start sequence is finished and D is reverse biased.

During the initial part of the start-up, the FB voltage can be approximated as follows. Note that the effect of R_1 has been ignored to simplify the calculation shown in [Equation 5](#).

$$V_{\text{FB}} = (V_{\text{CC}} - V_{\text{D}}) \times \frac{R_{\text{FB1}} \times R_{\text{FB2}}}{R_2 \times (R_{\text{FB1}} + R_{\text{FB2}}) + R_{\text{FB1}} \times R_{\text{FB2}}} \quad (8)$$

C_1 is charged after the first start-up. Diode D_1 is optional and can be added to discharge C_1 and initialize the soft-start sequence when the input voltage experiences a momentary drop.

LM5019

SNVS788H – JANUARY 2012 – REVISED AUGUST 2021

To achieve the desired soft start, the following design guidance is recommended:

1. R_2 is selected so that V_{FB} is higher than 1.225 V for a V_{CC} of 4.5 V, but is lower than 5 V when V_{CC} is 8.55 V. If an external V_{CC} is used, V_{FB} must not exceed 5 V at maximum V_{CC} .
2. C_1 is selected to achieve the desired start-up time that can be determined as shown in [Equation 6](#).

$$t_S = C_1 \times \left(R_2 + \frac{R_{FB1} \times R_{FB2}}{R_{FB1} + R_{FB2}} \right) \quad (9)$$

3. R_1 is used to maintain the node B voltage at zero after the soft start is finished. A value larger than the feedback resistor divider is preferred.

With component values from the applications from the schematic shown in [Figure 8-1](#), selecting $C_1 = 1 \mu\text{F}$, $R_2 = 1 \text{ k}\Omega$, and $R_1 = 30 \text{ k}\Omega$ results in a soft-start time of about 2 ms.

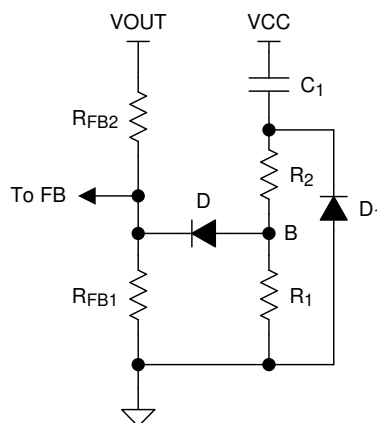

Figure 7-3. Soft-Start Circuit

7.4 Device Functional Modes

The UVLO pin controls the operating mode of the LM5019 device (see [Table 7-1](#) for the detailed functional states).

Table 7-1. UVLO Mode

UVLO	V_{CC}	MODE	DESCRIPTION
< 0.66 V	Disabled	Shutdown	V_{CC} regulator disabled. Switching disabled.
0.66 V to 1.225 V	Enabled	Standby	V_{CC} regulator enabled Switching disabled.
> 1.225 V	$V_{CC} < 4.5 \text{ V}$	Standby	V_{CC} regulator enabled. Switching disabled.
	$V_{CC} > 4.5 \text{ V}$	Operating	V_{CC} enabled. Switching enabled.

8 Application and Implementation

Note

Information in the following applications sections is not part of the TI component specification, and TI does not warrant its accuracy or completeness. TI's customers are responsible for determining suitability of components for their purposes, as well as validating and testing their design implementation to confirm system functionality.

8.1 Application Information

The LM5019 device is step-down DC-DC converter. The device is typically used to convert a higher DC voltage to a lower DC voltage with a maximum available output current of 100 mA. Use the following design procedure to select component values for the LM5019 device. Alternately, use the WEBENCH® software to generate a complete design. The WEBENCH software uses an iterative design procedure and accesses a comprehensive database of components when generating a design. This section presents a simplified discussion of the design process.

8.2 Typical Applications

8.2.1 Application Circuit: 12.5 V to 95 V Input and 10 V, 100-mA Output Buck Converter

The application schematic of a buck supply is shown in Figure 8-1. For output voltage (V_{OUT}) more than one diode drop higher than the maximum regulation threshold of V_{CC} (8.55 V, see Section 6.5), the V_{CC} pin can be connected to V_{OUT} through a diode (D2), to improve efficiency and reduce power dissipation in the IC.

The design example uses equations from the Section 7.3 with component names provided in the Figure 3-1 schematic. Corresponding component designators from Figure 8-1 are also provided for each selected value.

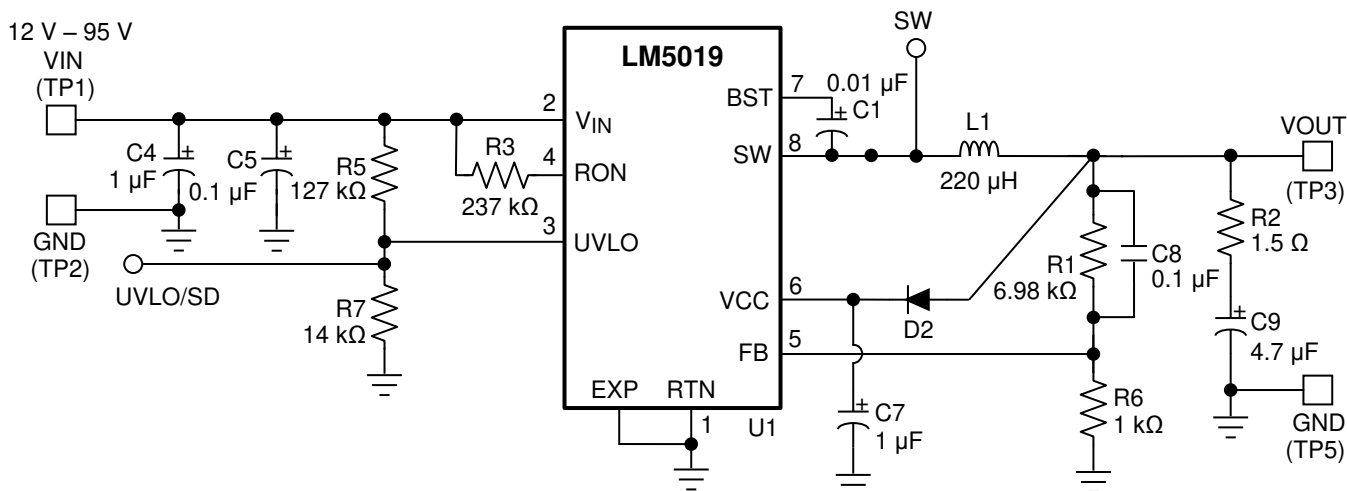

Figure 8-1. 12.5-V to 95-V Input and 10-V, 100-mA Output Buck Converter

LM5019

SNVS788H – JANUARY 2012 – REVISED AUGUST 2021

8.2.1.1 Design Requirements

Table 8-1 lists the design parameters for this example.

Table 8-1. Buck Converter Design Specifications

DESIGN PARAMETERS	VALUE
Input Range	12.5 V to 95 V, transients up to 100 V
Output Voltage	10 V
Maximum Output Current	100 mA
Nominal Switching Frequency	≈ 440 kHz

8.2.1.2 Detailed Design Procedure**8.2.1.2.1 Custom Design With WEBENCH® Tools**

[Click here](#) to create a custom design using the LM5019 device with the WEBENCH® Power Designer.

1. Start by entering the input voltage (V_{IN}), output voltage (V_{OUT}), and output current (I_{OUT}) requirements.
2. Optimize the design for key parameters such as efficiency, footprint, and cost using the optimizer dial.
3. Compare the generated design with other possible solutions from Texas Instruments.

The WEBENCH Power Designer provides a customized schematic along with a list of materials with real-time pricing and component availability.

In most cases, these actions are available:

- Run electrical simulations to see important waveforms and circuit performance
- Run thermal simulations to understand board thermal performance
- Export customized schematic and layout into popular CAD formats
- Print PDF reports for the design, and share the design with colleagues

Get more information about WEBENCH tools at www.ti.com/WEBENCH.

8.2.1.2.2 RFB1, RFB2

$V_{OUT} = V_{FB} \times (R_{FB2} / R_{FB1} + 1)$, and since $V_{FB} = 1.225$ V, the ratio of R_{FB2} to R_{FB1} calculates to be 7:1. Standard values are chosen with $R_{FB2} = R1 = 6.98$ k Ω and $R_{FB1} = R6 = 1.00$ k Ω are chosen. Other values can be used as long as the 7:1 ratio is maintained.

8.2.1.2.3 Frequency Selection

At the minimum input voltage, the maximum switching frequency of the LM5019 is restricted by the forced minimum off-time ($T_{OFF(MIN)}$) as given by [Equation 7](#).

$$f_{SW(MAX)} = \frac{1 - D_{MIN}}{T_{OFF(MIN)}} = \frac{1 - 10 / 12.5}{200 \text{ ns}} = 1 \text{ MHz} \quad (10)$$

Similarly, at maximum input voltage, the maximum switching frequency of the LM5019 is restricted by the minimum T_{ON} as given by [Equation 8](#).

$$f_{SW(MAX)} = \frac{D_{MIN}}{T_{ON(MIN)}} = \frac{10 / 48}{100 \text{ ns}} = 2.1 \text{ MHz} \quad (11)$$

Resistor R_{ON} sets the nominal switching frequency based on [Equation 9](#).

$$f_{SW} = \frac{V_{OUT}}{K \times R_{ON}} \quad (12)$$

where

- $K = 9 \times 10^{-11}$

Operation at high switching frequency results in lower efficiency while providing the smallest solution. For this example, 440 kHz was selected, resulting in $R_{ON} = 253 \text{ k}\Omega$. A standard value for $R_{ON} = R_3 = 237 \text{ k}\Omega$ is selected.

8.2.1.2.4 Inductor Selection

The inductance selection is a compromise between solution size, output ripple, and efficiency. The peak inductor current at maximum load current must be smaller than the minimum current limit threshold of 150 mA. The maximum permissible peak-to-peak inductor ripple is determined by [Equation 10](#).

$$\Delta I_L = 2 \times (I_{LIM(min)} - I_{OUT(max)}) = 2 \times 50 = 100 \text{ mA} \quad (13)$$

The minimum inductance is determined by [Equation 11](#).

$$\Delta I_L = \frac{V_{IN} - V_{OUT}}{L \times f_{SW}} \times \frac{V_{OUT}}{V_{IN}} \quad (14)$$

Using maximum V_{IN} of 95 V, the calculation from [Equation 11](#) results in $L = 203 \text{ }\mu\text{H}$. A standard value of 220 μH is selected. With this value of inductance, peak-to-peak minimum and maximum inductor current ripple of 27 mA and 92 mA occur at the minimum and maximum input voltages, respectively. For robust short circuit protection, the inductor saturation current should be higher than the maximum current limit threshold of 300 mA.

8.2.1.2.5 Output Capacitor

The output capacitor is selected to minimize the capacitive ripple across it. The maximum ripple is observed at maximum input voltage and is given by [Equation 12](#).

$$C_{OUT} = \frac{\Delta I_L}{8 \times f_{SW} \times \Delta V_{ripple}} \quad (15)$$

where

- ΔV_{ripple} is the voltage ripple across the capacitor
- and ΔI_L is the inductor ripple current.

Assuming $V_{IN} = 95 \text{ V}$ and substituting $\Delta V_{ripple} = 10 \text{ mV}$ gives $C_{OUT} = 2.6 \text{ }\mu\text{F}$. A 4.7- μF standard value is selected for $C_{OUT} = C_9$. An X5R or X7R type capacitor with a voltage rating 16 V or higher must be selected.

8.2.1.2.6 Type II Ripple Circuit

Type II ripple circuit as described in [Section 7.3.11](#) is chosen for this example. For a constant on-time converter to be stable, the injected in-phase ripple must be larger than the capacitive ripple on C_{OUT} .

Using type II ripple circuit equations with minimum FB pin ripple of 25 mV, the values of the series resistor R_C and ac coupling capacitor C_{ac} can be calculated.

$$C \geq \frac{5}{f_{SW} (R_{FB2} \parallel R_{FB1})}$$

$$R_C \geq \frac{25 \text{ mV}}{\Delta I_L(MIN)} \quad (16)$$

Assuming $R_{FB2} = 6.98 \text{ k}\Omega$ and $R_{FB1} = 1 \text{ k}\Omega$, the calculated minimum value of C_{ac} is 0.013 μF . A standard value of 0.1 μF is selected for $C_{ac} = C_8$. The value of the series output resistor R_C is calculated for the minimum input voltage condition when the inductor ripple current is at a minimum. Using [Equation 11](#) and assuming $V_{IN} = 12.5 \text{ V}$, the minimum inductor ripple current is 27 mA. The calculated minimum value of R_C is 0.93 Ω . A standard value of 1.5 Ω is selected for $R_C = R_2$ to provide additional ripple for stable switching at low V_{IN} .

LM5019

SNVS788H – JANUARY 2012 – REVISED AUGUST 2021

8.2.1.2.7 V_{CC} and Bootstrap Capacitor

The V_{CC} capacitor provides charge to bootstrap capacitor as well as internal circuitry and low-side gate driver. The bootstrap capacitor provides charge to the high-side gate driver. The recommended value for C_{VCC} = C7 is 1 μF. A good value for C_{BST} = C1 is 0.01 μF.

8.2.1.2.8 Input Capacitor

The input capacitor must be large enough to limit the input voltage ripple shown in [Equation 14](#).

$$C_{IN} \geq \frac{I_{OUT(MAX)}}{4 \times f_{SW} \times \Delta V_{IN}} \quad (17)$$

Choosing a $\Delta V_{IN} = 0.5 \text{ V}$ gives a minimum $C_{IN} = 0.12 \text{ } \mu\text{F}$. A standard value of $1.0 \text{ } \mu\text{F}$ is selected for $C_{IN} = C4$. The input capacitor must be rated for the maximum input voltage under all conditions. A 50-V, X7R dielectric must be selected for this design.

The input capacitor must be placed directly across V_{IN} and RTN (pin 2 and 1) of the IC. If it is not possible to place all of the input capacitor close to the IC, a 0.1-μF capacitor must be placed near the IC to provide a bypass path for the high frequency component of the switching current. This helps limit the switching noise.

8.2.1.2.9 UVLO

The UVLO resistors R_{UV1} and R_{UV2} set the UVLO threshold and hysteresis according to [Equation 15](#) and [Equation 16](#).

$$V_{IN(HYS)} = I_{HYS} \times R_{UV2} \quad (18)$$

where

- $I_{HYS} = 20 \text{ } \mu\text{A}$

$$V_{IN(UVLO, \text{rising})} = 1.225 \text{ V} \times \left(\frac{R_{UV2}}{R_{UV1}} + 1 \right) \quad (19)$$

For UVLO hysteresis of 2.5 V and UVLO rising threshold of 12 V, the calculated values of the UVLO resistors are R_{UV2} = 127 kΩ and R_{UV1} = 14.5 kΩ. Selecting standard values for R_{UV1} = R7 = 14 kΩ and R_{UV2} = R5 = 127 kΩ results in UVLO rising threshold of 12.5 V and hysteresis of 2.5 V.

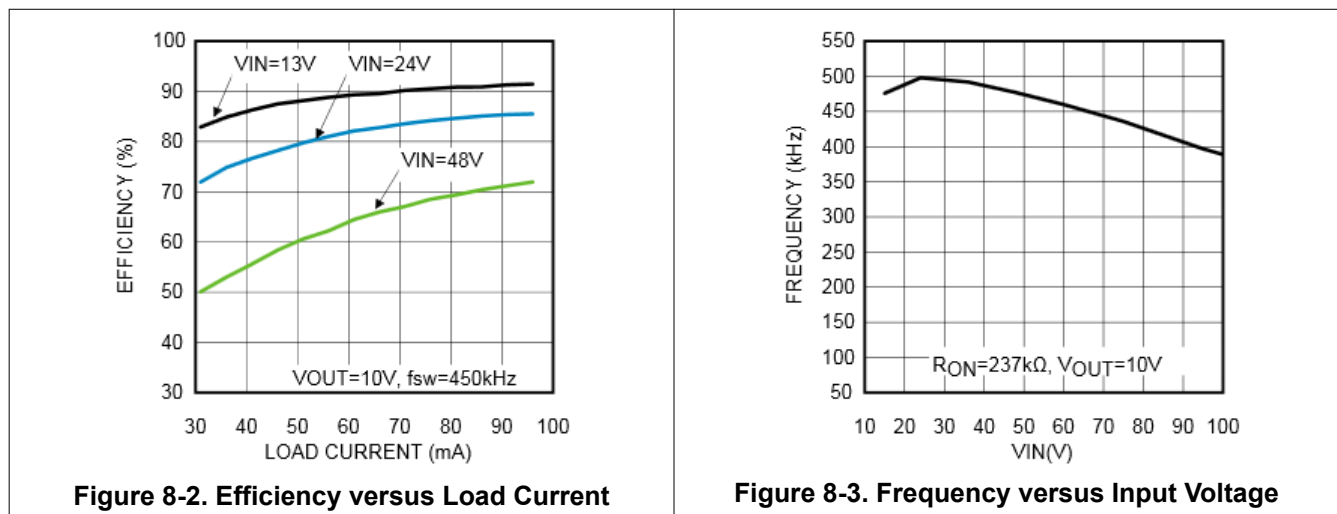
8.2.1.3 Application Curves

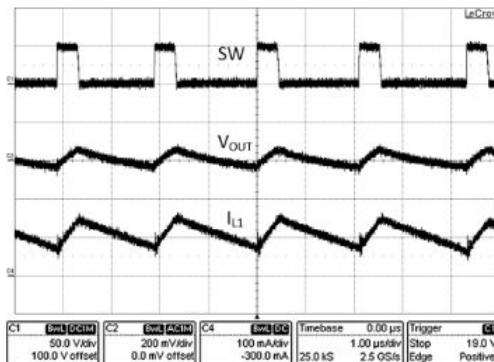

Figure 8-4. Typical Switching Waveform ($V_{IN} = 48\text{ V}$, $I_{OUT} = 100\text{ mA}$)

8.2.2 Application Circuit: 20 V to 95 V Input and 10 V, 100 mA Output Isolated Fly-Buck® Converter

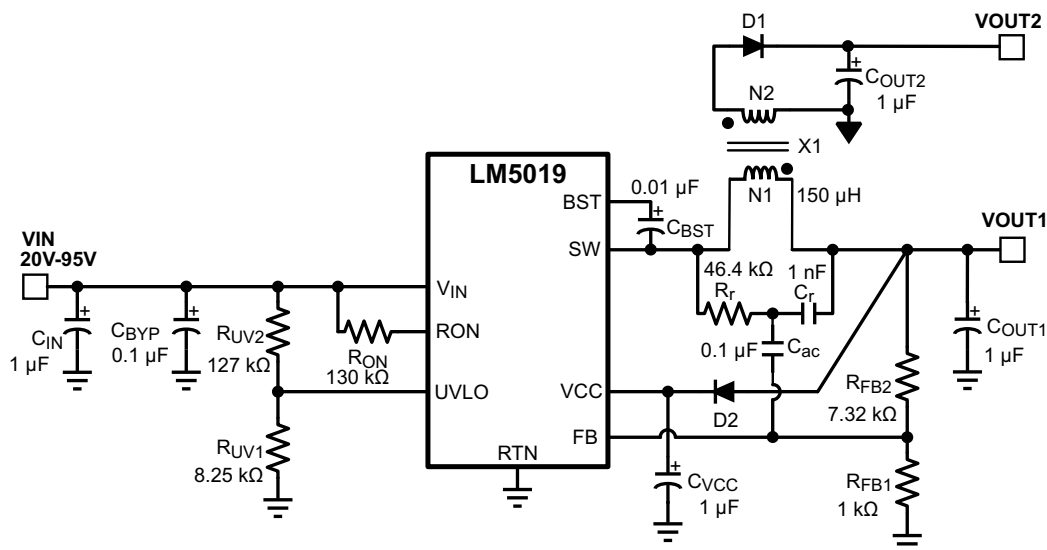

Figure 8-5. Isolated Fly-Buck™ Converter Using LM5019

8.2.2.1 Design Requirements

Selection of external components is illustrated through a design example. The design example specifications are shown in [Table 8-2](#).

Table 8-2. Buck Converter Design Specifications

DESIGN PARAMETERS	VALUE
Input Voltage Range	20 V to 95 V
Primary Output Voltage	10 V
Secondary (Isolated) Output Voltage	9.5 V
Maximum Output Current (Primary + Secondary)	100 mA
Maximum Power Output	1 W
Nominal Switching Frequency	750 kHz

LM5019

SNVS788H – JANUARY 2012 – REVISED AUGUST 2021

8.2.2.2 Detailed Design Procedure**8.2.2.2.1 Transformer Turns Ratio**

The transformer turns ratio is selected based on the ratio of the primary output voltage to the secondary (isolated) output voltage. In this design example, the two outputs are nearly equal and a 1:1 turns ratio transformer is selected. Therefore, $N_2 / N_1 = 1$.

If the secondary (isolated) output voltage is significantly higher or lower than the primary output voltage, a turns ratio less than or greater than 1 is recommended. The primary output voltage is normally selected based on the input voltage range such that the duty cycle of the converter does not exceed 50% at the minimum input voltage. This condition is satisfied if $V_{OUT1} < V_{IN_MIN} / 2$.

8.2.2.2.2 Total IOUT

The total primary referred load current is calculated by multiplying the isolated output load or loads by the turns ratio of the transformer as shown in [Equation 17](#).

$$I_{OUT(MAX)} = I_{OUT1} + I_{OUT2} \times \frac{N_2}{N_1} = 0.1 \text{ A} \quad (20)$$

8.2.2.2.3 RFB1, RFB2

The feedback resistors are selected to set the primary output voltage. The selected value for R_{FB1} is 1 k Ω . R_{FB2} can be calculated using the following equations to set V_{OUT1} to the specified value of 10 V. A standard resistor value of 7.32 k Ω is selected for R_{FB2} .

$$V_{OUT1} = 1.225 \text{ V} \times \left(1 + \frac{R_{FB2}}{R_{FB1}} \right) \quad (21)$$

$$\rightarrow R_{FB2} = \left(\frac{V_{OUT1}}{1.225} - 1 \right) \times R_{FB1} = 7.16 \text{ k}\Omega \quad (22)$$

8.2.2.2.4 Frequency Selection

[Equation 20](#) is used to calculate the value of R_{ON} required to achieve the desired switching frequency.

$$f_{SW} = \frac{V_{OUT1}}{K \times R_{ON}} \quad (23)$$

where

- $K = 9 \times 10^{-11}$

For V_{OUT1} of 10 V and f_{SW} of 750 kHz, the calculated value of R_{ON} is 148 k Ω . A lower value of 130 k Ω is selected for this design to allow for second order effects at high switching frequency that are not included in [Equation 1](#).

8.2.2.2.5 Transformer Selection

A coupled inductor or a flyback-type transformer is required for this topology. Energy is transferred from primary to secondary when the low-side synchronous switch of the buck converter is conducting.

The maximum inductor primary ripple current that can be tolerated without exceeding the buck switch peak current limit threshold (0.15 A minimum) is given by [Equation 21](#).

$$\Delta I_{L1} = \left(0.15 - I_{OUT1} - I_{OUT2} \times \frac{N_2}{N_1} \right) \times 2 = 0.1 \text{ A} \quad (24)$$

Using the maximum peak-to-peak inductor ripple current ΔI_{L1} from [Equation 21](#), the minimum inductor value is given by [Equation 22](#).

$$L1 = \frac{V_{IN(MAX)} - V_{OUT}}{\Delta I_{L1} \times f_{SW}} \times \frac{V_{OUT}}{V_{IN(MAX)}} = 119.3 \mu\text{H} \quad (25)$$

A higher value of 150 μH is selected to ensure the high-side switch current does not exceed the minimum peak current limit threshold.

8.2.2.2.6 Primary Output Capacitor

In a conventional buck converter, the output ripple voltage is calculated as shown in [Equation 23](#).

$$\Delta V_{OUT} = \frac{\Delta I_{L1}}{8 \times f \times C_{OUT1}} \quad (26)$$

To limit the primary output ripple voltage ΔV_{OUT1} to approximately 50 mV, an output capacitor C_{OUT1} of 0.33 μF is required.

[Figure 8-6](#) shows the primary winding current waveform (I_{L1}) of a Fly-Buck converter. The reflected secondary winding current adds to the primary winding current during the buck switch off-time. Because of this increased current, the output voltage ripple is not the same as in conventional buck converter. The output capacitor value calculated in [Equation 23](#) must be used as the starting point. Optimization of output capacitance over the entire line and load range must be done experimentally. If the majority of the load current is drawn from the secondary isolated output, a better approximation of the primary output voltage ripple is given by [Equation 24](#).

$$\Delta V_{OUT1} = \frac{\left(I_{OUT2} \times \frac{N2}{N1} \right) \times T_{ON(MAX)}}{C_{OUT1}} \approx 67 \text{ mV} \quad (27)$$

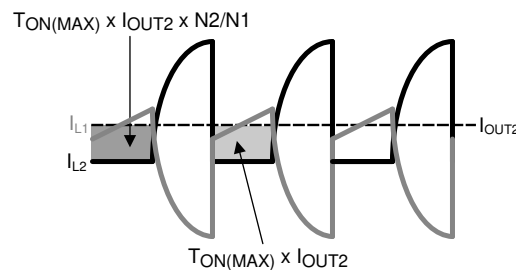

Figure 8-6. Current Waveforms for C_{OUT1} Ripple Calculation

A standard 1- μF , 25-V capacitor is selected for this design. If lower output voltage ripple is required, a higher value must be selected for C_{OUT1} , C_{OUT2} , or both.

8.2.2.2.7 Secondary Output Capacitor

A simplified waveform for secondary output current (I_{OUT2}) is shown in [Figure 8-7](#).

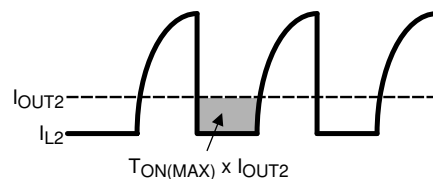

Figure 8-7. Secondary Current Waveforms for C_{OUT2} Ripple Calculation

The secondary output current (I_{OUT2}) is sourced by C_{OUT2} during on-time of the buck switch, T_{ON} . Ignoring the current transition times in the secondary winding, the secondary output capacitor ripple voltage can be calculated using [Equation 25](#).

LM5019

SNVS788H – JANUARY 2012 – REVISED AUGUST 2021

$$\Delta V_{OUT2} = \frac{I_{OUT2} \times T_{ON (MAX)}}{C_{OUT2}} \quad (28)$$

For a 1:1 transformer turns ratio, the primary and secondary voltage ripple equations are identical. Therefore, C_{OUT2} is chosen to be equal to C_{OUT1} (1 μ F) to achieve comparable ripple voltages on primary and secondary outputs.

If lower output voltage ripple is required, a higher value must be selected for C_{OUT1} , C_{OUT2} , or both.

8.2.2.2.8 Type III Feedback Ripple Circuit

A Type III ripple circuit as described in the [Section 7.3.11](#) section is required for the Fly-Buck topology. Type I and Type II ripple circuits use series resistance and the triangular inductor ripple current to generate ripple at V_{OUT} and the FB pin. The primary ripple current of a Fly-Buck is the combination of primary and reflected secondary currents as illustrated in [Figure 8-6](#). In the Fly-Buck topology, Type I and Type II ripple circuits suffer from large jitter as the reflected load current affects the feedback ripple.

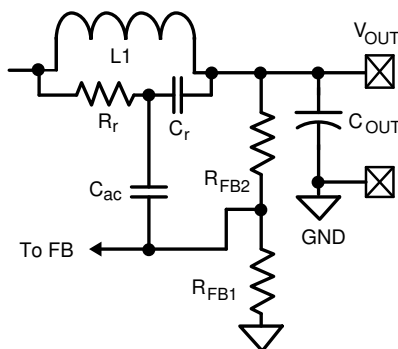
**Figure 8-8. Type III Ripple Circuit**

Selecting the Type III ripple components using the equations from the [Section 7.3.11](#) section ensures that the FB pin ripple is greater than the capacitive ripple from the primary output capacitor C_{OUT1} . The feedback ripple component values are chosen as shown in [Equation 26](#).

$$\begin{aligned} C_r &= 1000 \text{ pF} \\ C_{ac} &= 0.1 \text{ } \mu\text{F} \\ R_r C_r &\leq \frac{(V_{IN (MIN)} - V_{OUT}) \times T_{ON}}{50 \text{ mV}} \end{aligned} \quad (29)$$

The calculated value for R_r is 66 k Ω . This value provides the minimum ripple for stable operation. A smaller resistance must be selected to allow for variations in T_{ON} , C_{OUT1} , and other components. For this design, R_r value of 46.4 k Ω is selected.

8.2.2.2.9 Secondary Diode

The reverse voltage across secondary-rectifier diode D1 when the high-side buck switch is off can be calculated using [Equation 27](#).

$$V_{D1} = \frac{N2}{N1} V_{IN} \quad (30)$$

For a V_{IN_MAX} of 95 V and the 1:1 turns ratio of this design, a 100-V Schottky is selected.

8.2.2.2.10 V_{CC} and Bootstrap Capacitor

A 1- μ F capacitor of 16 V or higher rating is recommended for the V_{CC} regulator bypass capacitor.

A good value for the BST pin bootstrap capacitor is 0.01 μ F with a 16 V or higher rating.

8.2.2.2.11 Input Capacitor

The input capacitor is typically a combination of a smaller bypass capacitor located near the regulator IC and a larger bulk capacitor. The total input capacitance must be large enough to limit the input voltage ripple to a desired amplitude. For input ripple voltage ΔV_{IN} , C_{IN} can be calculated using [Equation 28](#).

$$C_{IN} \geq \frac{I_{OUT(MAX)}}{4 \times f \times \Delta V_{IN}} \quad (31)$$

Choosing a ΔV_{IN} of 0.5 V gives a minimum C_{IN} of 0.067 μ F. A standard value of 0.1 μ F is selected for C_{BYP} in this design. A bulk capacitor of higher value reduces voltage spikes due to parasitic inductance between the power source to the converter. A standard value of 1 μ F is selected for C_{IN} in this design. The voltage ratings of the two input capacitors should be greater than the maximum input voltage under all conditions.

8.2.2.2.12 UVLO Resistors

UVLO resistors R_{UV1} and R_{UV2} set the undervoltage lockout threshold and hysteresis according to [Equation 29](#) and [Equation 30](#).

$$V_{IN(HYS)} = I_{HYS} \times R_{UV2} \quad (32)$$

where

- $I_{HYS} = 20 \mu$ A, typical

$$V_{IN(UVLO, \text{rising})} = 1.225V \times \left(\frac{R_{UV2}}{R_{UV1}} + 1 \right) \quad (33)$$

For a UVLO hysteresis of 2.5 V and UVLO rising threshold of 20 V, [Equation 29](#) and [Equation 30](#) require R_{UV1} of 8.25 k Ω and R_{UV2} of 127 k Ω and these values are selected for this design example.

8.2.2.2.13 V_{CC} Diode

Diode D2 is an optional diode connected between V_{OUT1} and the V_{CC} regulator output pin. When V_{OUT1} is more than one diode drop greater than the V_{CC} voltage, the V_{CC} bias current is supplied from V_{OUT1} . This results in reduced power losses in the internal V_{CC} regulator which improves converter efficiency. V_{OUT1} must be set to a voltage at least one diode drop higher than 8.55 V (the maximum V_{CC} voltage) if D2 is used to supply bias current.

LM5019

SNVS788H – JANUARY 2012 – REVISED AUGUST 2021

8.2.2.3 Application Curves

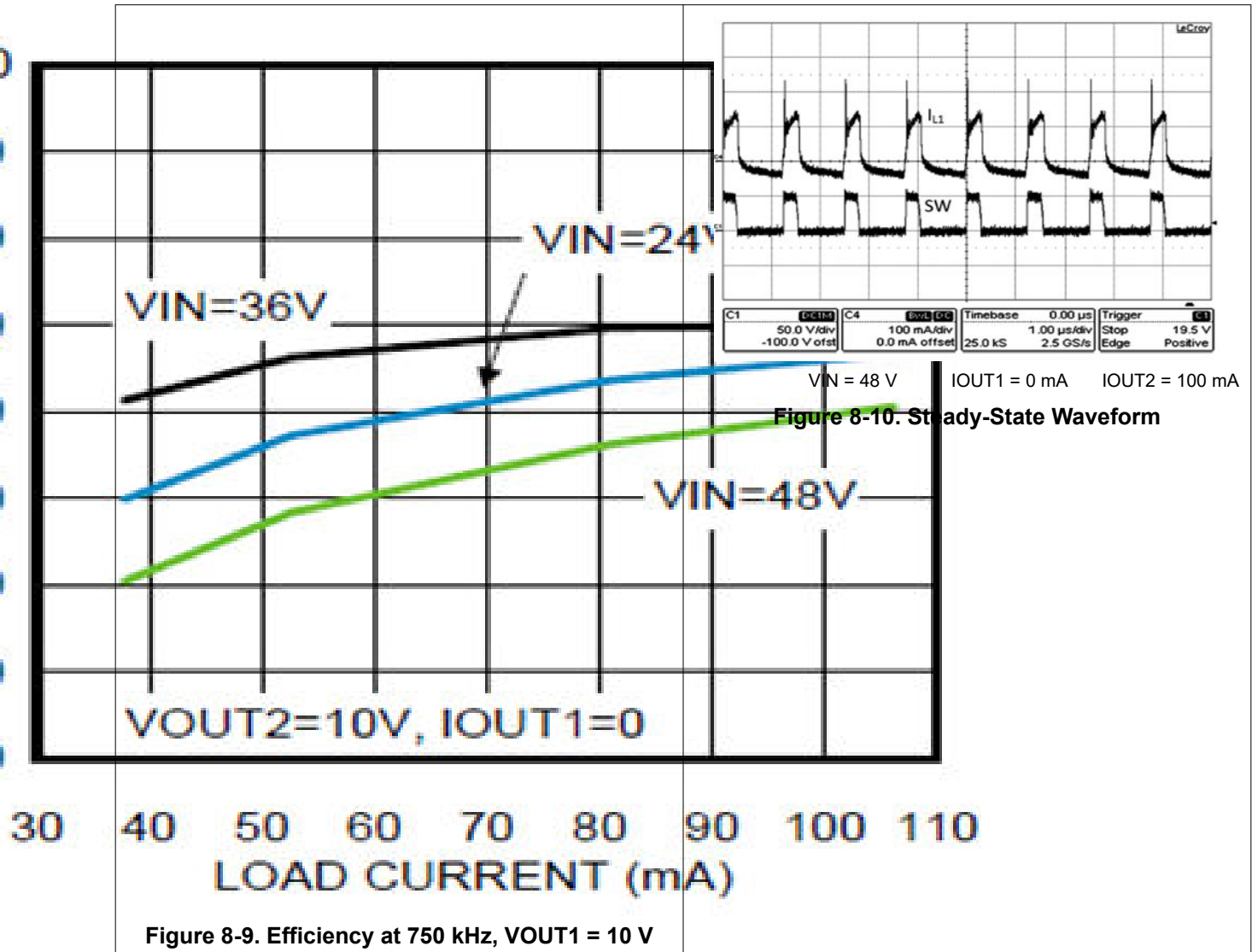

9 Power Supply Recommendations

The LM5019 is a power management device. The power supply for the device is any DC voltage source within the specified input range.

LM5019

SNVS788H – JANUARY 2012 – REVISED AUGUST 2021

10 Layout**10.1 Layout Guidelines**

A proper layout is essential for optimum performance of the circuit. In particular, the following guidelines should be observed:

1. C_{IN} : The loop consisting of input capacitor (C_{IN}), V_{IN} pin, and RTN pin carries switching currents. Therefore, the input capacitor should be placed close to the IC, directly across V_{IN} and RTN pins and the connections to these two pins must be direct to minimize the loop area. In general it is not possible to accommodate all of input capacitance near the IC. A good practice is to use a 0.1- μ F or 0.47- μ F capacitor directly across the V_{IN} and RTN pins close to the IC, and the remaining bulk capacitor as close as possible (see [Figure 10-1](#)).
2. C_{VCC} and C_{BST} : The V_{CC} and bootstrap (BST) bypass capacitors supply switching currents to the high and low side gate drivers. These two capacitors should also be placed as close to the IC as possible, and the connecting trace length and loop area must be minimized (see [Figure 10-1](#)).
3. The Feedback trace carries the output voltage information and a small ripple component that is necessary for proper operation of the LM5019. Therefore, care must be taken while routing the feedback trace to avoid coupling any noise to this pin. In particular, feedback trace must not run close to magnetic components, or parallel to any other switching trace.
4. SW trace: The SW node switches rapidly between V_{IN} and GND every cycle and is therefore a possible source of noise. The SW node area must be minimized. In particular, the SW node must not be inadvertently connected to a copper plane or pour.

10.2 Layout Example

Figure 10-1. Placement of Bypass Capacitors

11 Device and Documentation Support

11.1 Device Support

11.1.1 Third-Party Products Disclaimer

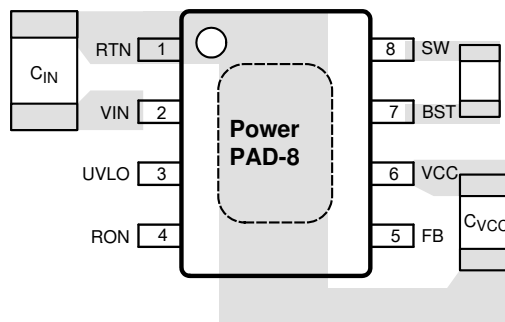
TI'S PUBLICATION OF INFORMATION REGARDING THIRD-PARTY PRODUCTS OR SERVICES DOES NOT CONSTITUTE AN ENDORSEMENT REGARDING THE SUITABILITY OF SUCH PRODUCTS OR SERVICES OR A WARRANTY, REPRESENTATION OR ENDORSEMENT OF SUCH PRODUCTS OR SERVICES, EITHER ALONE OR IN COMBINATION WITH ANY TI PRODUCT OR SERVICE.

11.1.2 Development Support

11.1.2.1 Custom Design With WEBENCH® Tools

[Click here](#) to create a custom design using the LM5019 device with the WEBENCH® Power Designer.

1. Start by entering the input voltage (V_{IN}), output voltage (V_{OUT}), and output current (I_{OUT}) requirements.
2. Optimize the design for key parameters such as efficiency, footprint, and cost using the optimizer dial.
3. Compare the generated design with other possible solutions from Texas Instruments.

The WEBENCH Power Designer provides a customized schematic along with a list of materials with real-time pricing and component availability.

In most cases, these actions are available:

- Run electrical simulations to see important waveforms and circuit performance
- Run thermal simulations to understand board thermal performance
- Export customized schematic and layout into popular CAD formats
- Print PDF reports for the design, and share the design with colleagues

Get more information about WEBENCH tools at www.ti.com/WEBENCH.

11.2 Documentation Support

11.2.1 Related Documentation

- Texas Instruments, [AN-2240 LM5019 Isolated Evaluation Board](#) (SNOU100)
- Texas Instruments, [PowerPAD™ Layout Guidelines](#) (SLOA120)
- Texas Instruments, [AN-1481 Controlling Output Ripple and Achieving ESR Independence in Constant On-Time \(COT\) Regulator Designs](#) (SNVA166)
- Texas Instruments, [AN-2238 LM5019 Buck Evaluation Board](#) (SNVA647)

11.3 Receiving Notification of Documentation Updates

To receive notification of documentation updates, navigate to the device product folder on ti.com. Click on *Subscribe to updates* to register and receive a weekly digest of any product information that has changed. For change details, review the revision history included in any revised document.

11.4 Support Resources

[TI E2E™ support forums](#) are an engineer's go-to source for fast, verified answers and design help — straight from the experts. Search existing answers or ask your own question to get the quick design help you need.

Linked content is provided "AS IS" by the respective contributors. They do not constitute TI specifications and do not necessarily reflect TI's views; see TI's [Terms of Use](#).

11.5 Trademarks

Fly-Buck™ and TI E2E™ are trademarks of Texas Instruments.

is a trademark of Texas Instruments.

Fly-Buck® are registered trademarks of TI.

WEBENCH® are registered trademarks of Texas Instruments.

All trademarks are the property of their respective owners.

LM5019SNVS788H – JANUARY 2012 – REVISED AUGUST 2021

11.6 Electrostatic Discharge Caution



This integrated circuit can be damaged by ESD. Texas Instruments recommends that all integrated circuits be handled with appropriate precautions. Failure to observe proper handling and installation procedures can cause damage.

ESD damage can range from subtle performance degradation to complete device failure. Precision integrated circuits may be more susceptible to damage because very small parametric changes could cause the device not to meet its published specifications.

11.7 Glossary

[TI Glossary](#) This glossary lists and explains terms, acronyms, and definitions.

12 Mechanical, Packaging, and Orderable Information

The following pages include mechanical, packaging, and orderable information. This information is the most current data available for the designated devices. This data is subject to change without notice and revision of this document. For browser-based versions of this data sheet, refer to the left-hand navigation.

PACKAGING INFORMATION

Orderable part number	Status (1)	Material type (2)	Package Pins	Package qty Carrier	RoHS (3)	Lead finish/ Ball material (4)	MSL rating/ Peak reflow (5)	Op temp (°C)	Part marking (6)
LM5019MR/NOPB	Active	Production	SO PowerPAD (DDA) 8	95 TUBE	Yes	SN	Level-3-260C-168 HR	-40 to 125	L5019 MR
LM5019MR/NOPB.A	Active	Production	SO PowerPAD (DDA) 8	95 TUBE	Yes	SN	Level-3-260C-168 HR	-40 to 125	L5019 MR
LM5019MRX/NOPB	Active	Production	SO PowerPAD (DDA) 8	2500 LARGE T&R	Yes	SN	Level-3-260C-168 HR	-40 to 125	L5019 MR
LM5019MRX/NOPB.A	Active	Production	SO PowerPAD (DDA) 8	2500 LARGE T&R	Yes	SN	Level-3-260C-168 HR	-40 to 125	L5019 MR
LM5019SD/NOPB	Active	Production	WSON (NGU) 8	1000 SMALL T&R	Yes	SN	Level-1-260C-UNLIM	-40 to 125	L5019
LM5019SD/NOPB.A	Active	Production	WSON (NGU) 8	1000 SMALL T&R	Yes	SN	Level-1-260C-UNLIM	-40 to 125	L5019
LM5019SDX/NOPB	Active	Production	WSON (NGU) 8	4500 LARGE T&R	Yes	SN	Level-1-260C-UNLIM	-40 to 125	L5019
LM5019SDX/NOPB.A	Active	Production	WSON (NGU) 8	4500 LARGE T&R	Yes	SN	Level-1-260C-UNLIM	-40 to 125	L5019

(1) **Status:** For more details on status, see our [product life cycle](#).

(2) **Material type:** When designated, preproduction parts are prototypes/experimental devices, and are not yet approved or released for full production. Testing and final process, including without limitation quality assurance, reliability performance testing, and/or process qualification, may not yet be complete, and this item is subject to further changes or possible discontinuation. If available for ordering, purchases will be subject to an additional waiver at checkout, and are intended for early internal evaluation purposes only. These items are sold without warranties of any kind.

(3) **RoHS values:** Yes, No, RoHS Exempt. See the [TI RoHS Statement](#) for additional information and value definition.

(4) **Lead finish/Ball material:** Parts may have multiple material finish options. Finish options are separated by a vertical ruled line. Lead finish/Ball material values may wrap to two lines if the finish value exceeds the maximum column width.

(5) **MSL rating/Peak reflow:** The moisture sensitivity level ratings and peak solder (reflow) temperatures. In the event that a part has multiple moisture sensitivity ratings, only the lowest level per JEDEC standards is shown. Refer to the shipping label for the actual reflow temperature that will be used to mount the part to the printed circuit board.

(6) **Part marking:** There may be an additional marking, which relates to the logo, the lot trace code information, or the environmental category of the part.

Multiple part markings will be inside parentheses. Only one part marking contained in parentheses and separated by a "-" will appear on a part. If a line is indented then it is a continuation of the previous line and the two combined represent the entire part marking for that device.

Important Information and Disclaimer: The information provided on this page represents TI's knowledge and belief as of the date that it is provided. TI bases its knowledge and belief on information provided by third parties, and makes no representation or warranty as to the accuracy of such information. Efforts are underway to better integrate information from third parties. TI has taken and continues to take reasonable steps to provide representative and accurate information but may not have conducted destructive testing or chemical analysis on incoming materials and chemicals. TI and TI suppliers consider certain information to be proprietary, and thus CAS numbers and other limited information may not be available for release.

In no event shall TI's liability arising out of such information exceed the total purchase price of the TI part(s) at issue in this document sold by TI to Customer on an annual basis.

TAPE AND REEL INFORMATION

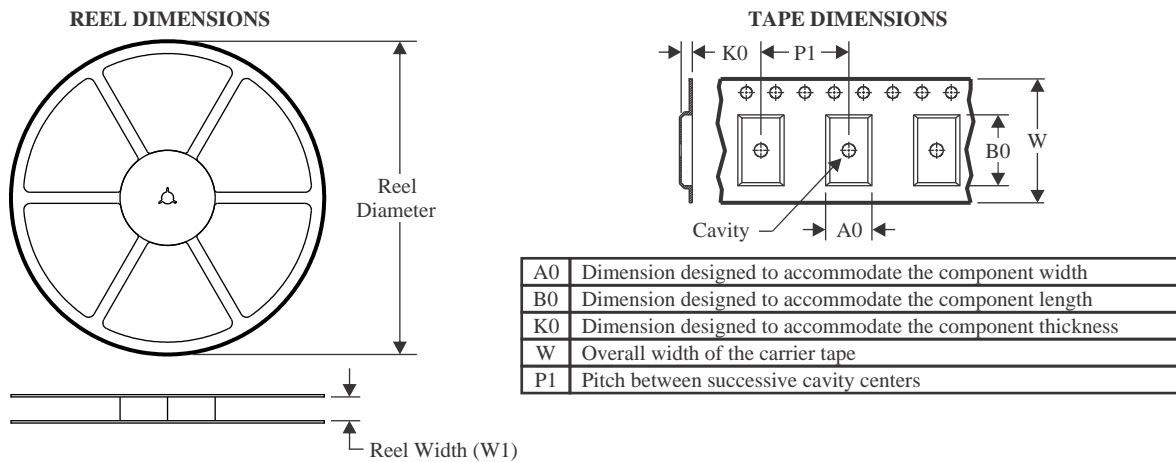

QUADRANT ASSIGNMENTS FOR PIN 1 ORIENTATION IN TAPE

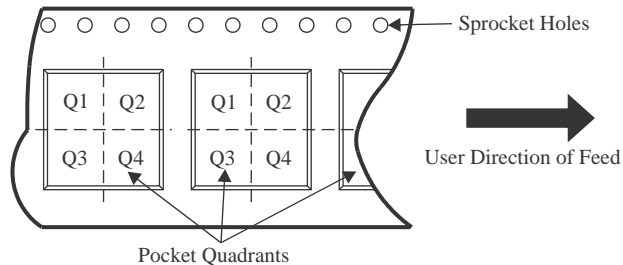

*All dimensions are nominal

Device	Package Type	Package Drawing	Pins	SPQ	Reel Diameter (mm)	Reel Width W1 (mm)	A0 (mm)	B0 (mm)	K0 (mm)	P1 (mm)	W (mm)	Pin1 Quadrant
LM5019MRX/NOPB	SO PowerPAD	DDA	8	2500	330.0	12.4	6.5	5.4	2.0	8.0	12.0	Q1
LM5019SD/NOPB	WSON	NGU	8	1000	177.8	12.4	4.3	4.3	1.3	8.0	12.0	Q1
LM5019SDX/NOPB	WSON	NGU	8	4500	330.0	12.4	4.3	4.3	1.3	8.0	12.0	Q1

TAPE AND REEL BOX DIMENSIONS

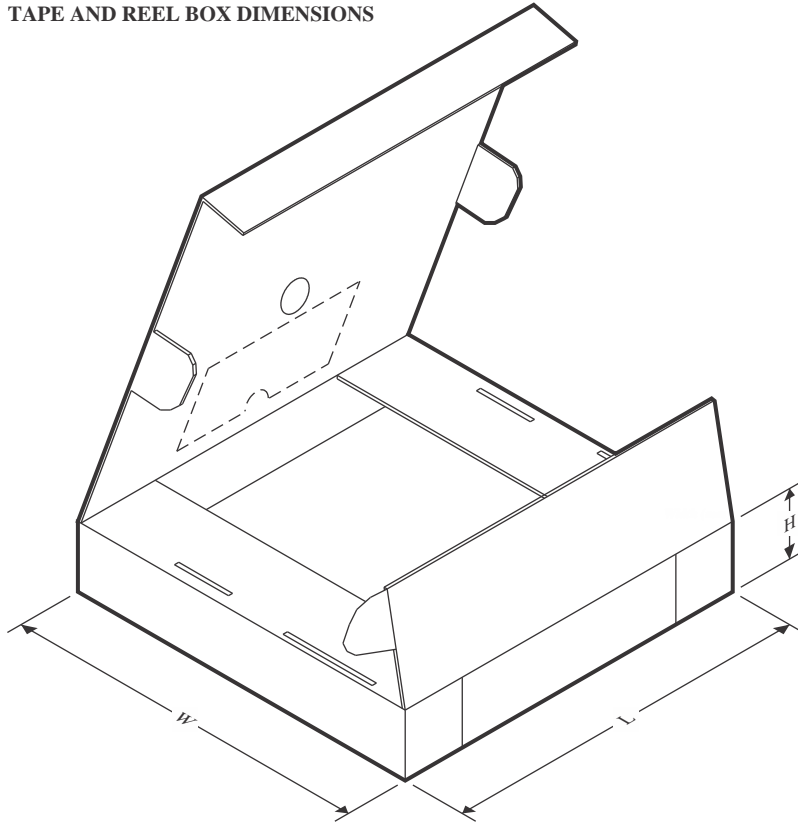

*All dimensions are nominal

Device	Package Type	Package Drawing	Pins	SPQ	Length (mm)	Width (mm)	Height (mm)
LM5019MRX/NOPB	SO PowerPAD	DDA	8	2500	356.0	356.0	36.0
LM5019SD/NOPB	WSON	NGU	8	1000	208.0	191.0	35.0
LM5019SDX/NOPB	WSON	NGU	8	4500	367.0	367.0	35.0

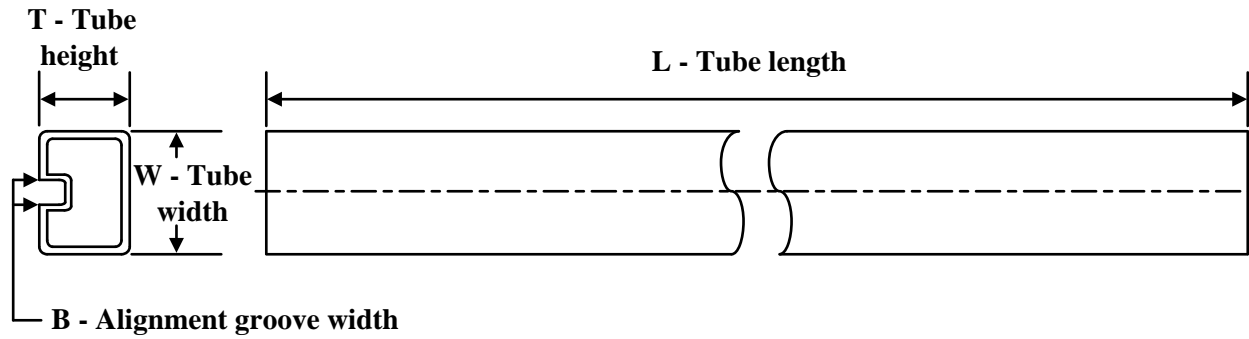
TUBE

*All dimensions are nominal

Device	Package Name	Package Type	Pins	SPQ	L (mm)	W (mm)	T (μm)	B (mm)
LM5019MR/NOPB	DDA	HSOIC	8	95	495	8	4064	3.05
LM5019MR/NOPB.A	DDA	HSOIC	8	95	495	8	4064	3.05

PACKAGE OUTLINE

DDA0008B

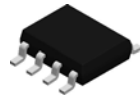

PowerPAD™ SOIC - 1.7 mm max height

PLASTIC SMALL OUTLINE

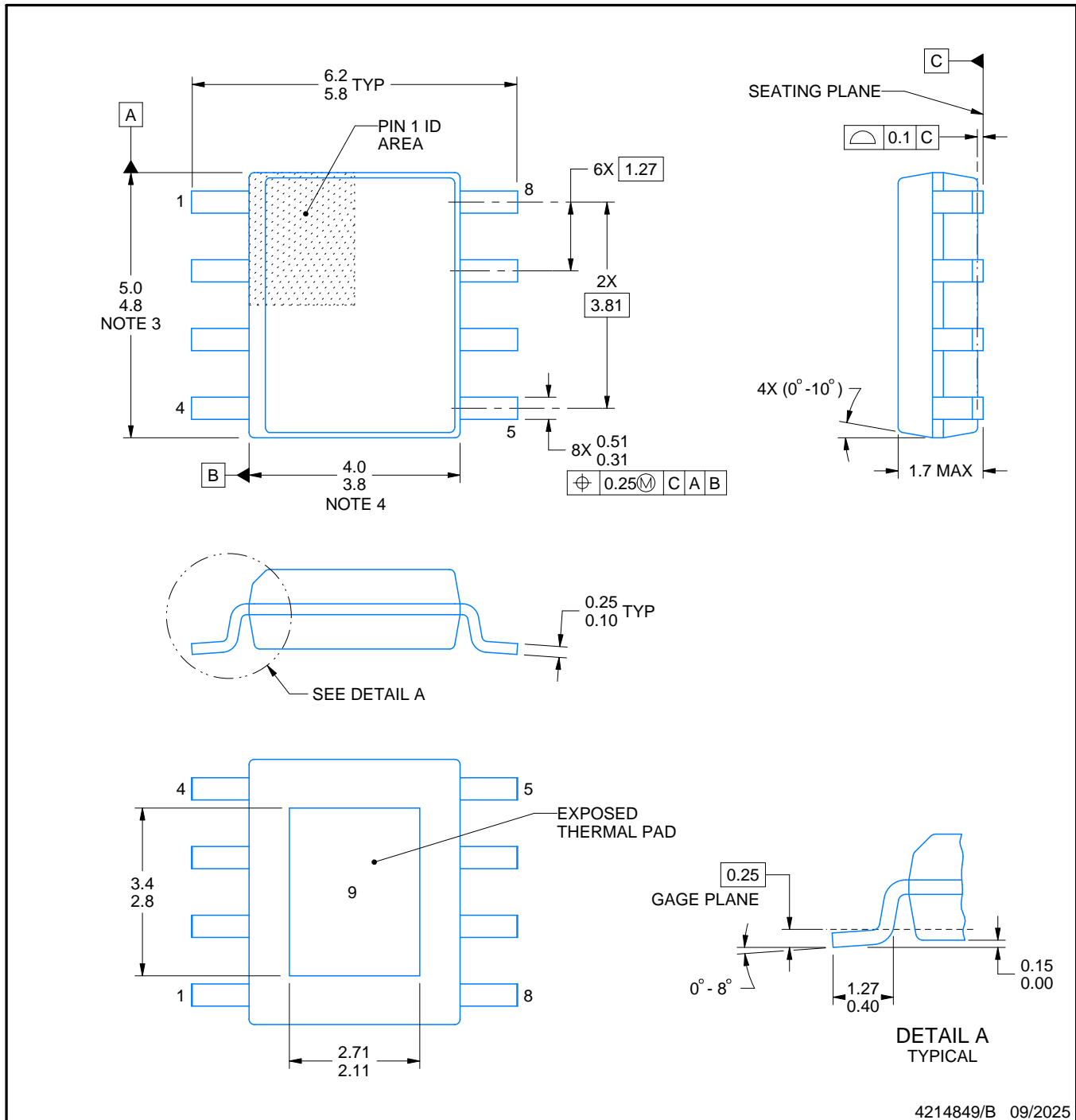

PowerPAD is a trademark of Texas Instruments.

NOTES:

1. All linear dimensions are in millimeters. Any dimensions in parenthesis are for reference only. Dimensioning and tolerancing per ASME Y14.5M.
2. This drawing is subject to change without notice.
3. This dimension does not include mold flash, protrusions, or gate burrs. Mold flash, protrusions, or gate burrs shall not exceed 0.15 mm per side.
4. This dimension does not include interlead flash. Interlead flash shall not exceed 0.25 mm per side.
5. Reference JEDEC registration MS-012.

EXAMPLE BOARD LAYOUT

DDA0008B

PowerPAD™ SOIC - 1.7 mm max height

PLASTIC SMALL OUTLINE

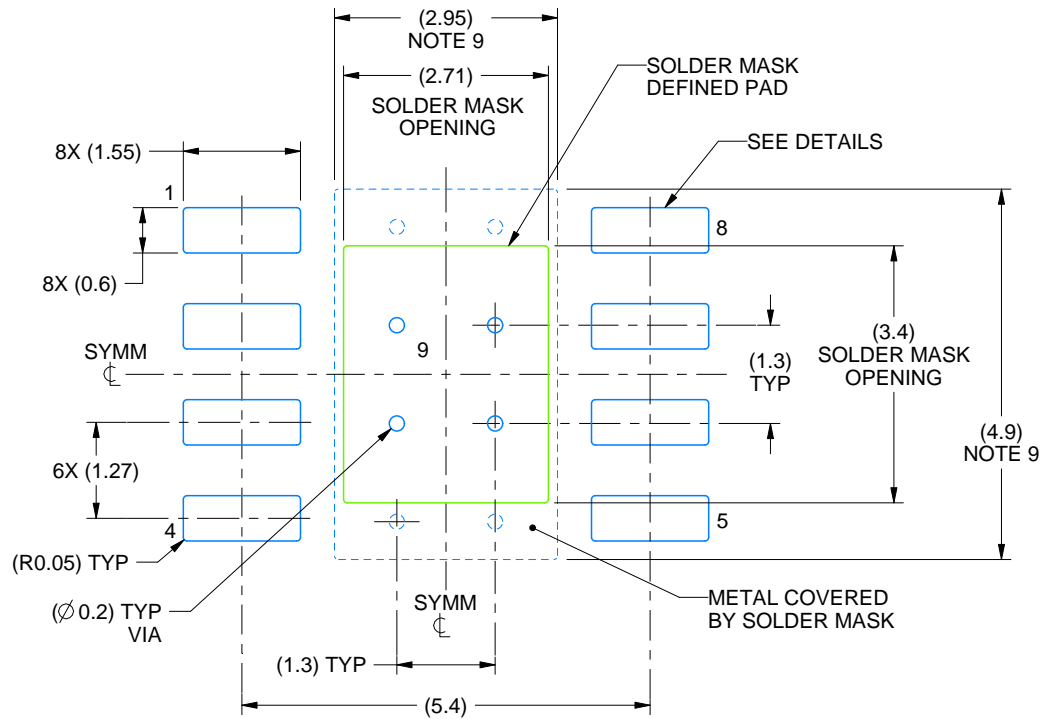
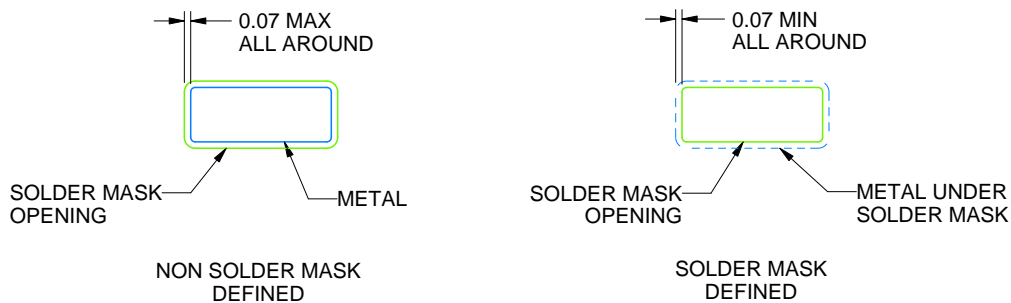
LAND PATTERN EXAMPLE
SCALE:10XSOLDER MASK DETAILS
PADS 1-8

4214849/B 09/2025

NOTES: (continued)

6. Publication IPC-7351 may have alternate designs.
7. Solder mask tolerances between and around signal pads can vary based on board fabrication site.
8. This package is designed to be soldered to a thermal pad on the board. For more information, see Texas Instruments literature numbers SLMA002 (www.ti.com/lit/slma002) and SLMA004 (www.ti.com/lit/slma004).
9. Size of metal pad may vary due to creepage requirement.
10. Vias are optional depending on application, refer to device data sheet. If any vias are implemented, refer to their locations shown on this view. It is recommended that vias under paste be filled, plugged or tented.

EXAMPLE STENCIL DESIGN**DDA0008B****PowerPAD™ SOIC - 1.7 mm max height**

PLASTIC SMALL OUTLINE

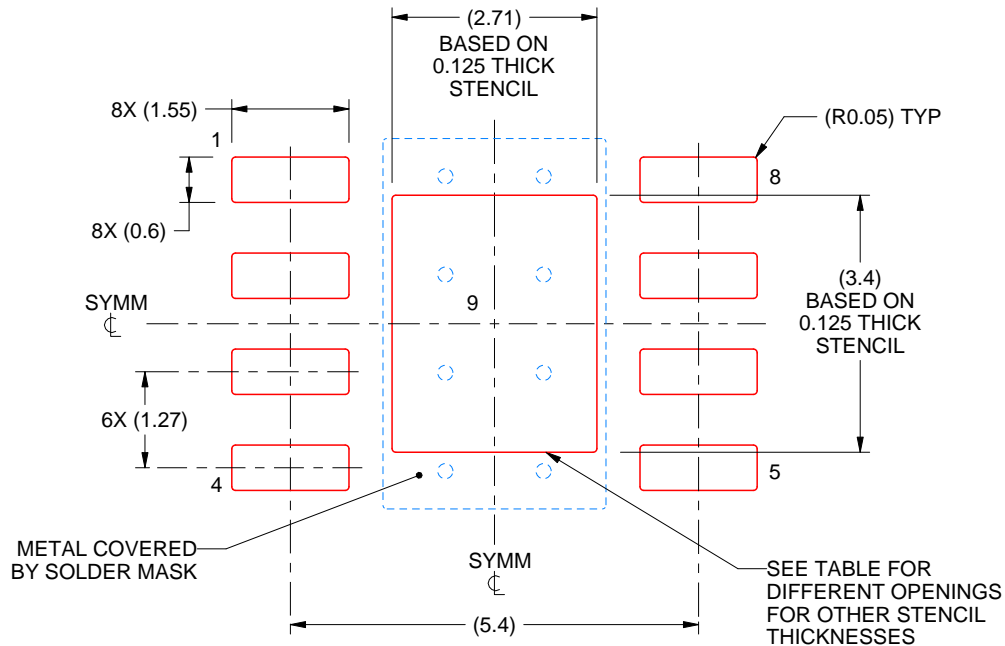

SOLDER PASTE EXAMPLE
EXPOSED PAD
100% PRINTED SOLDER COVERAGE BY AREA
SCALE:10X

STENCIL THICKNESS	SOLDER STENCIL OPENING
0.1	3.03 X 3.80
0.125	2.71 X 3.40 (SHOWN)
0.150	2.47 X 3.10
0.175	2.29 X 2.87

4214849/B 09/2025

NOTES: (continued)

11. Laser cutting apertures with trapezoidal walls and rounded corners may offer better paste release. IPC-7525 may have alternate design recommendations.
12. Board assembly site may have different recommendations for stencil design.

EXAMPLE STENCIL DESIGN**NGU0008B****WS0N - 0.8 mm max height**

PLASTIC SMALL OUTLINE - NO LEAD

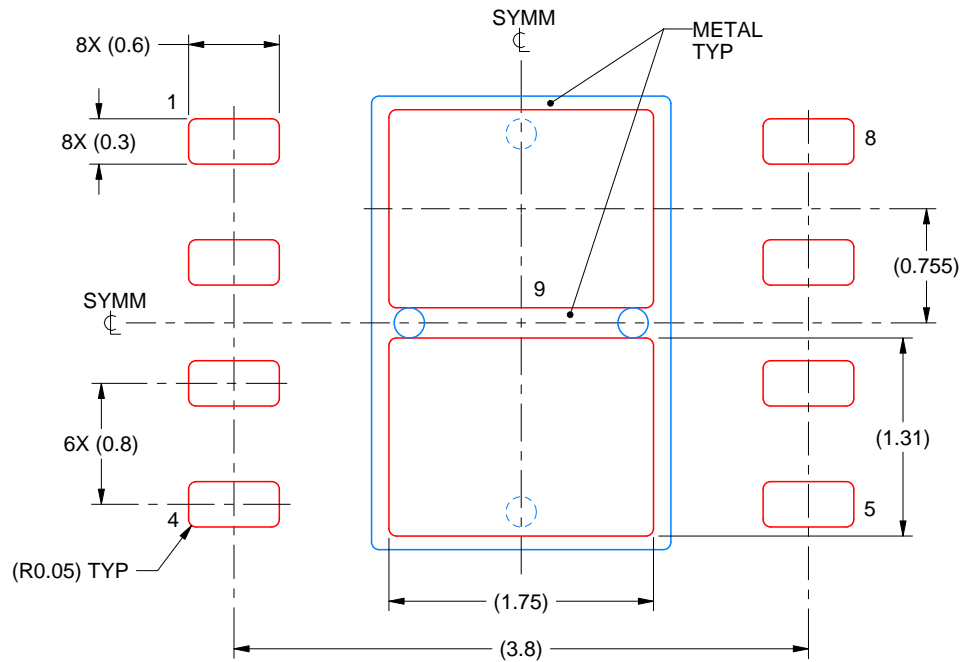

SOLDER PASTE EXAMPLE
 BASED ON 0.125 mm THICK STENCIL

EXPOSED PAD 9:
 77% PRINTED SOLDER COVERAGE BY AREA UNDER PACKAGE
 SCALE:20X

4214936/A 12/2023

NOTES: (continued)

6. Laser cutting apertures with trapezoidal walls and rounded corners may offer better paste release. IPC-7525 may have alternate design recommendations.

IMPORTANT NOTICE AND DISCLAIMER

TI PROVIDES TECHNICAL AND RELIABILITY DATA (INCLUDING DATASHEETS), DESIGN RESOURCES (INCLUDING REFERENCE DESIGNS), APPLICATION OR OTHER DESIGN ADVICE, WEB TOOLS, SAFETY INFORMATION, AND OTHER RESOURCES "AS IS" AND WITH ALL FAULTS, AND DISCLAIMS ALL WARRANTIES, EXPRESS AND IMPLIED, INCLUDING WITHOUT LIMITATION ANY IMPLIED WARRANTIES OF MERCHANTABILITY, FITNESS FOR A PARTICULAR PURPOSE OR NON-INFRINGEMENT OF THIRD PARTY INTELLECTUAL PROPERTY RIGHTS.

These resources are intended for skilled developers designing with TI products. You are solely responsible for (1) selecting the appropriate TI products for your application, (2) designing, validating and testing your application, and (3) ensuring your application meets applicable standards, and any other safety, security, regulatory or other requirements.

These resources are subject to change without notice. TI grants you permission to use these resources only for development of an application that uses the TI products described in the resource. Other reproduction and display of these resources is prohibited. No license is granted to any other TI intellectual property right or to any third party intellectual property right. TI disclaims responsibility for, and you fully indemnify TI and its representatives against any claims, damages, costs, losses, and liabilities arising out of your use of these resources.

TI's products are provided subject to [TI's Terms of Sale](#), [TI's General Quality Guidelines](#), or other applicable terms available either on ti.com or provided in conjunction with such TI products. TI's provision of these resources does not expand or otherwise alter TI's applicable warranties or warranty disclaimers for TI products. Unless TI explicitly designates a product as custom or customer-specified, TI products are standard, catalog, general purpose devices.

TI objects to and rejects any additional or different terms you may propose.

Copyright © 2025, Texas Instruments Incorporated

Last updated 10/2025

OUR CERTIFICATE

DiGi provide top-quality products and perfect service for customer worldwide through standardization, technological innovation and continuous improvement. DiGi through third-party certification, we stricly control the quality of products and services. Welcome your RFQ to

Email: Info@DiGi-Electronics.com



Tel: +00 852-30501935

RFQ Email: Info@DiGi-Electronics.com

DiGi is a global authorized distributor of electronic components.