

# LM5030MM Datasheet

[www.digi-electronics.com](http://www.digi-electronics.com)

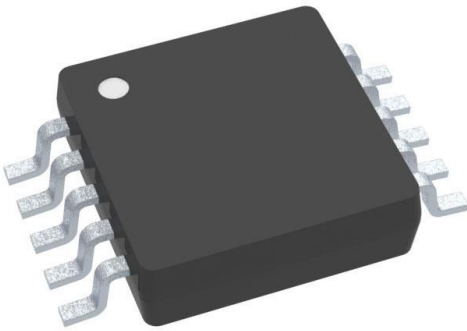

LM5030MM

<https://www.DiGi-Electronics.com>

DiGi Electronics Part Number	LM5030MM-DG
Manufacturer	<a href="#">Texas Instruments</a>
Manufacturer Product Number	LM5030MM
Description	IC REG CTRLR MULT TOP 10MSOP
Detailed Description	Full-Bridge, Half-Bridge, Push-Pull Regulator Positive, Isolation Capable Output Step-Up/Step-Down DC-DC Controller IC 10-VSSOP



Tel: +00 852-30501935

RFQ Email: [Info@DiGi-Electronics.com](mailto:Info@DiGi-Electronics.com)

DiGi is a global authorized distributor of electronic components.

## Purchase and inquiry

Manufacturer Product Number:

LM5030MM

Series:

-

Output Type:

Transistor Driver

Output Configuration:

Positive, Isolation Capable

Number of Outputs:

2

Voltage - Supply (Vcc/Vdd):

14V ~ 90V

Duty Cycle (Max):

50%

Clock Sync:

No

Control Features:

Frequency Control, Soft Start

Mounting Type:

Surface Mount

Supplier Device Package:

10-VSSOP

Manufacturer:

Texas Instruments

Product Status:

Last Time Buy

Function:

Step-Up/Step-Down

Topology:

Full-Bridge, Half-Bridge, Push-Pull

Output Phases:

1

Frequency - Switching:

200kHz, 600kHz

Synchronous Rectifier:

No

Serial Interfaces:

-

Operating Temperature:

-40°C ~ 105°C (TA)

Package / Case:

10-TFSOP, 10-MSOP (0.118", 3.00mm Width)

Base Product Number:

LM5030

## Environmental & Export classification

RoHS Status:

ROHS3 Compliant

REACH Status:

REACH Unaffected

HTSUS:

8542.39.0001

Moisture Sensitivity Level (MSL):

1 (Unlimited)

ECCN:

EAR99

## LM5030 100-V Push-Pull Current Mode PWM Controller

### 1 Features

- Internal High-Voltage Start-Up Regulator
- Single Resistor Oscillator Setting
- Synchronizable
- Error Amplifier
- Precision Reference
- Adjustable Softstart
- Dual Mode Overcurrent Protection
- Slope Compensation
- Direct Optocoupler Interface
- 1.5-A Peak Gate Drivers
- Thermal Shutdown

### 2 Applications

- Telecommunication Power Converters
- Industrial Power Converters
- +42-V Automotive Systems

### 3 Description

The LM5030 high-voltage PWM controller contains all of the features needed to implement push-pull and bridge topologies, using current-mode control in a small 10-pin package. This device provides two alternating gate driver outputs. The LM5030 includes a high-voltage start-up regulator that operates over a wide input range of 14 V to 100 V. Additional features include: error amplifier, precision reference, dual mode current limit, slope compensation, softstart, sync capability, and thermal shutdown. This high speed IC has total propagation delays less than 100 ns and a 1-MHz capable single-resistor adjustable oscillator.

#### Device Information<sup>(1)</sup>

PART NUMBER	PACKAGE	BODY SIZE (NOM)
LM5030	VSSOP (10)	3.00 mm x 3.00 mm
	WSON (10)	4.00 mm x 4.00 mm

(1) For all available packages, see the orderable addendum at the end of the data sheet.

#### Typical Application Diagram

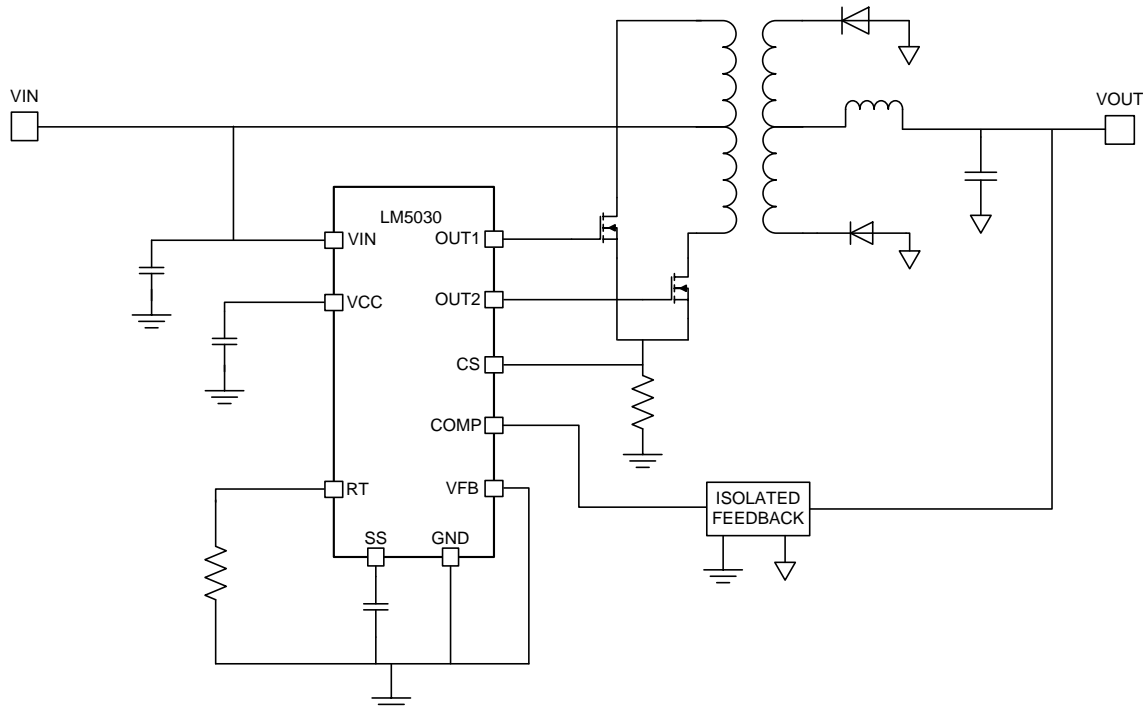

## Table of Contents

<b>1 Features</b> .....	<b>1</b>	7.4 Device Functional Modes.....	<b>13</b>
<b>2 Applications</b> .....	<b>1</b>	<b>8 Application and Implementation</b> .....	<b>14</b>
<b>3 Description</b> .....	<b>1</b>	8.1 Application Information.....	<b>14</b>
<b>4 Revision History</b> .....	<b>2</b>	8.2 Typical Application .....	<b>14</b>
<b>5 Pin Configuration and Functions</b> .....	<b>3</b>	<b>9 Power Supply Recommendations</b> .....	<b>20</b>
<b>6 Specifications</b> .....	<b>4</b>	<b>10 Layout</b> .....	<b>20</b>
6.1 Absolute Maximum Ratings .....	<b>4</b>	10.1 Layout Guidelines .....	<b>20</b>
6.2 ESD Ratings.....	<b>4</b>	10.2 Layout Example .....	<b>20</b>
6.3 Recommended Operating Conditions.....	<b>4</b>	<b>11 Device and Documentation Support</b> .....	<b>21</b>
6.4 Thermal Information .....	<b>4</b>	11.1 Device Support.....	<b>21</b>
6.5 Electrical Characteristics.....	<b>5</b>	11.2 Documentation Support .....	<b>21</b>
6.6 Typical Characteristics.....	<b>8</b>	11.3 Community Resources.....	<b>21</b>
<b>7 Detailed Description</b> .....	<b>10</b>	11.4 Trademarks .....	<b>21</b>
7.1 Overview .....	<b>10</b>	11.5 Electrostatic Discharge Caution.....	<b>21</b>
7.2 Functional Block Diagram .....	<b>10</b>	11.6 Glossary .....	<b>21</b>
7.3 Feature Description.....	<b>11</b>	<b>12 Mechanical, Packaging, and Orderable Information</b> .....	<b>21</b>

## 4 Revision History

NOTE: Page numbers for previous revisions may differ from page numbers in the current version.

<b>Changes from Revision C (March 2013) to Revision D</b>	<b>Page</b>
<ul style="list-style-type: none"> <li>Added <i>ESD Ratings</i> table, <i>Thermal Information</i> table, <i>Feature Description</i> section, <i>Device Functional Modes</i>, <i>Application and Implementation</i> section, <i>Power Supply Recommendations</i> section, <i>Layout</i> section, <i>Device and Documentation Support</i> section, and <i>Mechanical, Packaging, and Orderable Information</i> section.....</li> </ul>	<b>1</b>

<b>Changes from Revision B (March 2013) to Revision C</b>	<b>Page</b>
<ul style="list-style-type: none"> <li>Changed layout of National Data Sheet to TI format .....</li> </ul>	<b>16</b>

## 5 Pin Configuration and Functions

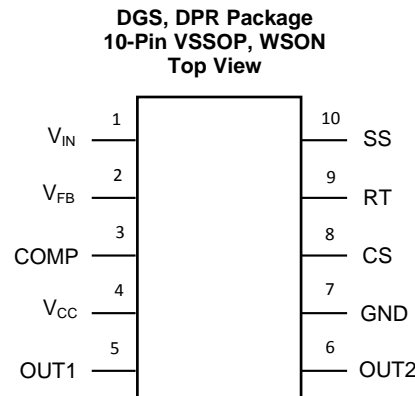

### Pin Functions

PIN		I/O	DESCRIPTION	APPLICATION INFORMATION
NAME	NO.			
COMP	3	O	Output to the error amplifier	There is an internal 5-kΩ pullup resistor on this pin. The error amplifier provides an active sink.
CS	8	I	Current sense input	Current sense input for current mode control and current limit sensing. Using separate dedicated comparators, if CS exceeds 0.5 V, the outputs will go into cycle-by-cycle current limit. If CS exceeds 0.625 V the outputs will be disabled and a softstart commenced.
GND	7	—	Return	Ground
OUT1	5	O	Output of the PWM controller	Alternating PWM output gate driver
OUT2	6	O	Output of the PWM controller	Alternating PWM output gate driver
RT	9	I	Oscillator timing resistor pin and synchronization input	An external resistor sets the oscillator frequency. This pin will also accept synchronization pulses from an external oscillator.
SS	10	I	Dual purpose soft start and shutdown pin	A 10-μA current source and an external capacitor set the softstart timing length. The controller will enter a low power state if the SS pin is pulled below the typical shutdown threshold of 0.45 V.
V <sub>IN</sub>	1	I	Source input voltage	Input to start-up regulator. Input range 14 to 100 V.
V <sub>FB</sub>	2	I	Inverting input to the error amplifier	The non-inverting input is internally connected to a 1.25-V reference.
V <sub>CC</sub>	4	I/O	Output from the internal high-voltage series pass regulator. The regulation setpoint is 7.7 V.	If an auxiliary winding raises the voltage on this pin above the regulation setpoint, the internal series pass regulator will shutdown, reducing the IC power dissipation.
WSON DAP	SUB	—	Die substrate	The exposed die attach pad on the WSON package should be connected to a PCB thermal pad at ground potential. For additional information on using TI's No Pull Back WSON package, refer to WSON Application Note AN-1187 (SNOA401).

**LM5030**

SNVS215D – APRIL 2003 – REVISED NOVEMBER 2015

www.ti.com

**6 Specifications****6.1 Absolute Maximum Ratings**over operating free-air temperature range (unless otherwise noted) <sup>(1)</sup>

	MIN	MAX	UNIT
V <sub>IN</sub> to GND (Survival)	–0.3	100	V
V <sub>CC</sub> to GND (Survival)	–0.3	16	V
RT to GND (Survival)	–0.3	5.5	V
All other pins to GND (Survival)	–0.3	7	V
Power dissipation	Internally Limited		
Lead temperature (soldering 4 seconds)		260	°C
Operating junction temperature		150	°C
Storage temperature, T <sub>stg</sub>	–55	150	°C

(1) Stresses beyond those listed under *Absolute Maximum Ratings* may cause permanent damage to the device. These are stress ratings only, which do not imply functional operation of the device at these or any other conditions beyond those indicated under *Recommended Operating Conditions*. Exposure to absolute-maximum-rated conditions for extended periods may affect device reliability.

**6.2 ESD Ratings**

		VALUE	UNIT
V <sub>(ESD)</sub> Electrostatic discharge	Human body model (HBM), per ANSI/ESDA/JEDEC JS-001 <sup>(1)</sup>	±2000	V
	Machine model (MM)	±200	

(1) JEDEC document JEP155 states that 500-V HBM allows safe manufacturing with a standard ESD control process.

**6.3 Recommended Operating Conditions**

over operating free-air temperature range (unless otherwise noted)

	MIN	NOM	MAX	UNIT
V <sub>IN</sub>	14		90	V
T <sub>J</sub> Operating junction temperature	–40		105	°C

**6.4 Thermal Information**

THERMAL METRIC <sup>(1)</sup>	LM5030		UNIT
	DGS (VSSOP)	DPR (WSON)	
	10 PINS	10 PINS	
R <sub>θJA</sub> Junction-to-ambient thermal resistance	158.8	38.1	°C/W
R <sub>θJC(top)</sub> Junction-to-case (top) thermal resistance	53.6	137.1	°C/W
R <sub>θJB</sub> Junction-to-board thermal resistance	74.8	15.2	°C/W
Ψ <sub>JT</sub> Junction-to-top characterization parameter	5.3	0.4	°C/W
Ψ <sub>JB</sub> Junction-to-board characterization parameter	77.6	15.4	°C/W
R <sub>θJC(bot)</sub> Junction-to-case (bottom) thermal resistance	—	4.6	°C/W

(1) For more information about traditional and new thermal metrics, see the *Semiconductor and IC Package Thermal Metrics* application report, [SPRA953](#).

## 6.5 Electrical Characteristics

Specifications are for  $T_J = 25^\circ\text{C}$ . Unless otherwise specified:  $V_{IN} = 48\text{ V}$ ,  $V_{CC} = 10\text{ V}$ , and  $R_T = 26.7\text{ k}\Omega$

PARAMETER	TEST CONDITIONS	MIN <sup>(1)</sup>	TYP <sup>(2)</sup>	MAX <sup>(1)</sup>	UNIT
<b>START-UP REGULATOR</b>					
$V_{CC\text{Reg}}$ $V_{CC}$ Regulation	Open ckt	$T_J = 25^\circ\text{C}$	7.7		V
		full operating junction temperature range	7.4	8.0	
$V_{CC}$ Current limit	See <a href="#">Figure 2</a>	$T_J = 25^\circ\text{C}$	17		mA
		full operating junction temperature range	10		
$I_{-V_{IN}}$ Start-up regulator leakage (external $V_{CC}$ supply)	$V_{IN} = 90\text{ V}$	$T_J = 25^\circ\text{C}$	150		$\mu\text{A}$
		full operating junction temperature range		500	
$I_{IN}$ Shutdown current	SS = 0 V, $V_{CC} =$ open	$T_J = 25^\circ\text{C}$	250		$\mu\text{A}$
		full operating junction temperature range		350	
<b><math>V_{CC}</math> SUPPLY</b>					
$V_{CC}$ Undervoltage lockout voltage	$T_J = 25^\circ\text{C}$		$V_{CC\text{Reg}} - 100\text{ mV}$		V
		full operating junction temperature range	$V_{CC\text{Reg}} - 300\text{ mV}$		
Undervoltage hysteresis	$T_J = 25^\circ\text{C}$		1.6		V
		full operating junction temperature range	1.2	2.1	
$I_{CC}$ Supply current	$C_{\text{load}} = 0$	$T_J = 25^\circ\text{C}$	2		mA
		full operating junction temperature range		3	
<b>ERROR AMPLIFIER</b>					
GBW Gain bandwidth			4		MHz
DC gain			75		dB
Input voltage	$V_{FB} = \text{COMP}$	$T_J = 25^\circ\text{C}$	1.245		V
		full operating junction temperature range	1.220	1.270	
COMP sink capability	$V_{FB} = 1.5\text{ V COMP} = 1\text{ V}$	$T_J = 25^\circ\text{C}$	13		mA
		full operating junction temperature range	5		
<b>CURRENT LIMIT</b>					
CS1 Cycle-by-cyble CS threshold voltage	$T_J = 25^\circ\text{C}$		0.5		V
		full operating junction temperature range	0.45	0.55	
CS2 Restart CS threshold voltage	Resets SS capacitor; auto restart	$T_J = 25^\circ\text{C}$	0.625		V
		full operating junction temperature range	0.575	0.675	
ILIM delay to output	CS step from 0-V to 0.6-V time-to-onset of OUT transition (90%) $C_{\text{load}} = 0$		30		ns
CS sink current (clocked)	CS = 0.3 V	$T_J = 25^\circ\text{C}$	6		mA
		full operating junction temperature range	3		

- (1) Limits are 100% production tested at  $25^\circ\text{C}$ . Limits over the operating temperature range are specified through correlation using Statistical Quality Control (SQC) methods. The limits are used to calculate TI's Average Outgoing Quality Level (AOQL).
- (2) Typical numbers represent the most likely parametric norm for  $25^\circ\text{C}$  operation.

**LM5030**

SNVS215D – APRIL 2003 – REVISED NOVEMBER 2015

www.ti.com

**Electrical Characteristics (continued)**Specifications are for  $T_J = 25^\circ\text{C}$ . Unless otherwise specified:  $V_{IN} = 48\text{ V}$ ,  $V_{CC} = 10\text{ V}$ , and  $R_T = 26.7\text{ k}\Omega$ 

PARAMETER	TEST CONDITIONS		MIN <sup>(1)</sup>	TYP <sup>(2)</sup>	MAX <sup>(1)</sup>	UNIT
<b>SOFT START AND SHUTDOWN</b>						
Softstart current source	$T_J = 25^\circ\text{C}$		10		13	$\mu\text{A}$
	full operating junction temperature range		7			
Softstart to COMP offset	$T_J = 25^\circ\text{C}$		0.5		0.75	V
	full operating junction temperature range		0.25			
Shutdown threshold	$T_J = 25^\circ\text{C}$		0.45		0.7	V
	full operating junction temperature range		0.2			
<b>OSCILLATOR</b>						
Frequency1 (RT = 26.7K)	$T_J = 25^\circ\text{C}$		200		225	kHz
	full operating junction temperature range		175			
Frequency2 (RT = 8.2K)	$T_J = 25^\circ\text{C}$		600		690	kHz
	full operating junction temperature range		510			
Sync threshold	$T_J = 25^\circ\text{C}$		3.2		3.8	V
	full operating junction temperature range					
<b>PWM COMPARATOR</b>						
Delay to output	COMP set to 2-V CS stepped 0 to 0.4 V, time-to-onset of OUT transition low		30			ns
Max duty cycle	Inferred from deadtime	$T_J = 25^\circ\text{C}$	49%		50%	
		full operating junction temperature range	47.5%			
Min duty cycle	COMP = 0 V	full operating junction temperature range			0%	
COMP to PWM comparator gain			0.34			V / V
COMP open circuit voltage	$V_{FB} = 0\text{ V}$	$T_J = 25^\circ\text{C}$	5.2		6.1	V
		full operating junction temperature range	4.3			
COMP short circuit current	$V_{FB} = 0\text{ V}$ , COMP = 0 V	$T_J = 25^\circ\text{C}$	1.1		1.5	mA
		full operating junction temperature range	0.6			
<b>SLOPE COMPENSATION</b>						
Slope comp amplitude	Delta increase at PWM Comparator to CS	$T_J = 25^\circ\text{C}$	105		130	mV
		full operating junction temperature range	80			
<b>OUTPUT SECTION</b>						
Deadtime	$C_{load} = 0, 10\% \text{ to } 10\%$	$T_J = 25^\circ\text{C}$	135		185	ns
		full operating junction temperature range	85			
Output high saturation	$I_{out} = 50\text{ mA}$ , $V_{CC} - V_{OUT}$	$T_J = 25^\circ\text{C}$	0.25		0.75	V
		full operating junction temperature range				
Output low saturation	$I_{OUT} = 100\text{ mA}$	$T_J = 25^\circ\text{C}$	0.25		0.75	V
		full operating junction temperature range				
Rise time	$C_{load} = 1\text{ nF}$			16		ns
Fall time	$C_{load} = 1\text{ nF}$			16		ns

**Electrical Characteristics (continued)**

Specifications are for  $T_J = 25^\circ\text{C}$ . Unless otherwise specified:  $V_{IN} = 48\text{ V}$ ,  $V_{CC} = 10\text{ V}$ , and  $R_T = 26.7\text{ k}\Omega$

PARAMETER		TEST CONDITIONS	MIN <sup>(1)</sup>	TYP <sup>(2)</sup>	MAX <sup>(1)</sup>	UNIT
<b>THERMAL SHUTDOWN</b>						
$T_{sd}$	Thermal shutdown temperature			165		$^\circ\text{C}$
	Thermal shutdown hysteresis			15		$^\circ\text{C}$

**LM5030**

SNVS215D – APRIL 2003 – REVISED NOVEMBER 2015

www.ti.com

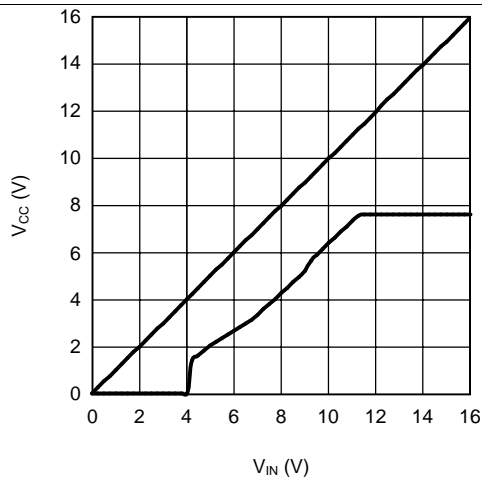
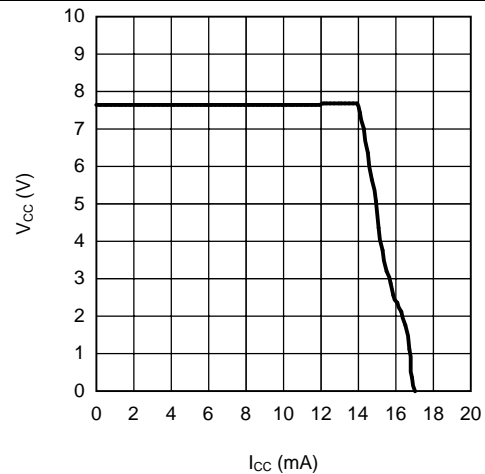
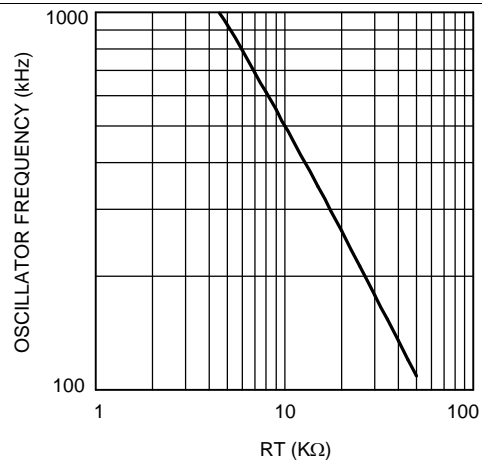
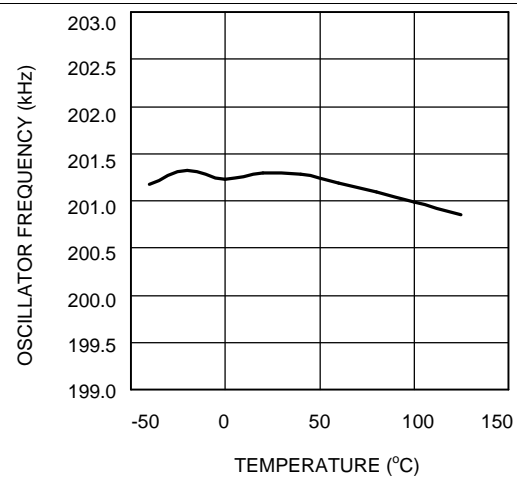
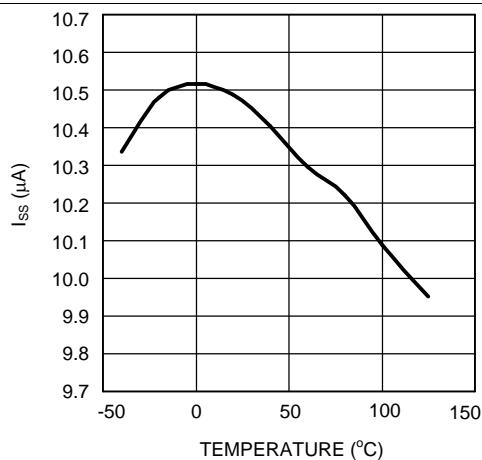
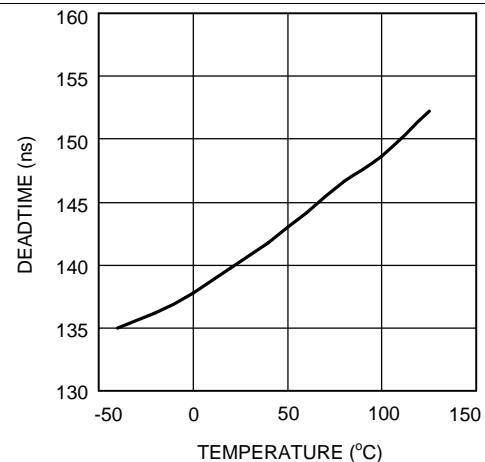
**6.6 Typical Characteristics**at  $T_J = 25^\circ\text{C}$  (unless otherwise noted)**Figure 1.  $V_{CC}$  vs  $V_{IN}$** **Figure 2.  $V_{CC}$  vs  $I_{CC}$  ( $V_{IN} = 48\text{ V}$ )****Figure 3. Oscillator Frequency vs  $RT$** **Figure 4. Oscillator Frequency vs Temperature  $RT = 26.7\text{ k}\Omega$** **Figure 5. Softstart Current vs Temperature****Figure 6. Deadtime vs Temperature**

## Typical Characteristics (continued)

at  $T_J = 25^\circ\text{C}$  (unless otherwise noted)

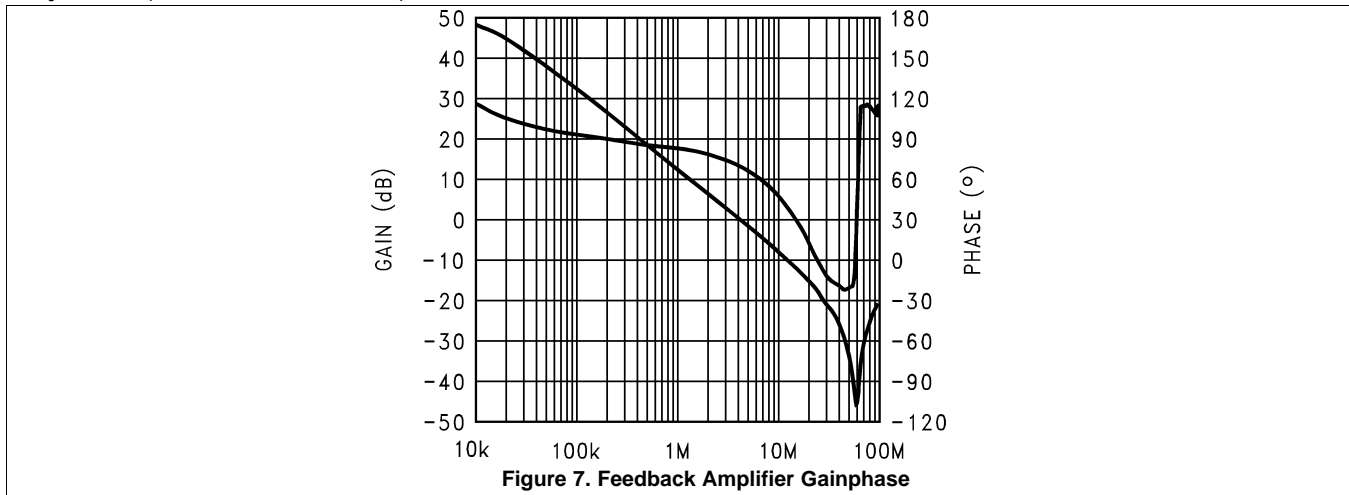

## LM5030

SNVS215D – APRIL 2003 – REVISED NOVEMBER 2015

www.ti.com

## 7 Detailed Description

### 7.1 Overview

The LM5030 high-voltage PWM controller contains all of the features needed to implement push-pull and bridge topologies, using current-mode control in a small 10-pin package. Features included are, start-up regulator, dual mode current limit, dual alternating gate drivers, thermal shutdown, softstart, and slope compensation. This high speed IC has total propagation delays < 100 ns. The functional block diagram of the LM5030 is shown in [Functional Block Diagram](#).

The LM5030 is designed for current-mode control converters that require alternating outputs, such as push-pull and half- and full-bridge topologies. The features included in the LM5030 enable all of the advantages of current-mode control, line feed-forward, cycle-by-cycle current limit, and simplified loop compensation. The oscillator ramp is internally buffered and added to the PWM comparator input to provide the necessary slope compensation for current-mode control at higher duty cycles.

### 7.2 Functional Block Diagram

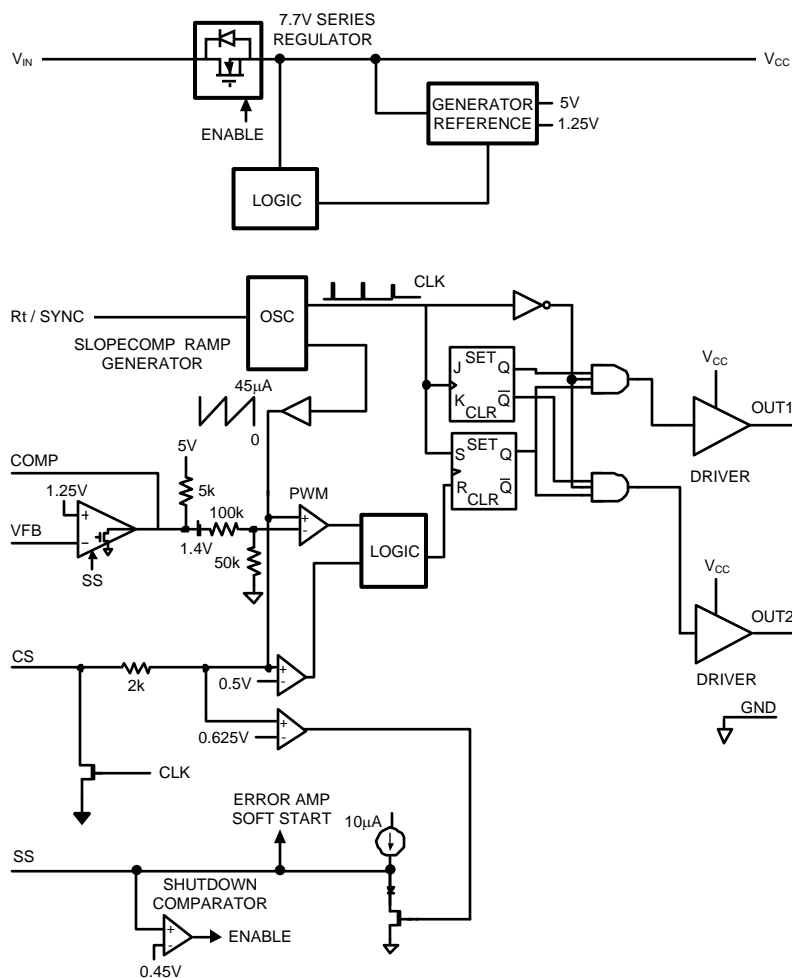

## 7.3 Feature Description

### 7.3.1 High-Voltage Start-Up Regulator

The LM5030 contains an internal high-voltage start-up regulator. The input pin ( $V_{IN}$ ) can be connected directly to line voltages as high as 100 V. The regulator output is internally current limited to 10 mA. Upon power up, the regulator is enabled and sources current into an external capacitor connected to the  $V_{CC}$  pin. The recommended capacitance range for the  $V_{CC}$  regulator is 0.1  $\mu$ F to 50  $\mu$ F. When the voltage on the  $V_{CC}$  pin reaches the regulation point of 7.7 V, the controller outputs are enabled. The outputs will remain enabled unless,  $V_{CC}$  falls below 6.1 V or if the SS/SHUTDOWN pin is pulled to ground or an over temperature condition occurs. In typical applications, an auxiliary transformer winding is diode connected to the  $V_{CC}$  pin. This winding raises the  $V_{CC}$  voltage greater than 8 V, effectively shutting off the internal start-up regulator and saving power while reducing the controller dissipation. The external  $V_{CC}$  capacitor must be sized such that the self-bias will maintain a  $V_{CC}$  voltage greater than 6.1 V during the initial start-up. During a fault mode when the converter self bias winding is inactive, external current draw on the  $V_{CC}$  line should be limited as to not exceed the maximum power dissipation of the controller. An external start-up or other bias rail can be used instead of the internal start-up regulator by connecting the  $V_{CC}$  and the  $V_{in}$  pins and feeding the external bias voltage (8 V to 15 V) to that node.

### 7.3.2 Error Amplifier

An internal high gain error amplifier is provided within the LM5030. The noninverting reference of the amplifier is tied to 1.25 V. In nonisolated applications the power converter output is connected to the VFB pin via the voltage setting resistors and loop compensation is connected between the COMP and VFB pins.

For most isolated applications the error amplifier function is implemented on the secondary side ground. Because the internal error amplifier is configured as an open drain output it can be disabled by connecting VFB to ground. The internal 5-k $\Omega$  pullup resistor, connected between the 5-V reference and COMP, can be used as the pullup for an optocoupler or other isolation device.

### 7.3.3 PWM Comparator

The PWM comparator compares the compensated current ramp signal to the loop error voltage from the internal error amplifier (COMP pin). This comparator is optimized for speed in order to achieve minimum discernable duty cycles. The comparator polarity is such that 0 V on the COMP pin will cause a zero duty cycle.

### 7.3.4 Current Limit and Current Sense

The LM5030 contains two levels of over-current protection. If the voltage on the current sense comparator exceeds 0.5 V the present cycle is terminated (cycle-by-cycle current limit). If the voltage on the current sense comparator exceeds 0.625 V, the controller will terminate the present cycle and discharge the softstart capacitor. A small RC filter, located near the controller, is recommended for the CS pin. An internal MOSFET discharges the current sense filter capacitor at the conclusion of every cycle, to improve dynamic performance.

The LM5030 CS and PWM comparators are very fast, and as such will respond to short duration noise pulses. Layout considerations are critical for the current sense filter and sense resistor. The capacitor associated with the CS filter must be placed very close to the device and connected directly to the pins of the IC (CS and RTN). Also if a current sense transformer is used, both leads of the transformer secondary should be routed to the sense resistor, which should also be located close to the IC. If a current sense resistor located in the drive transistor sources is used, for current sense, a low inductance resistor should be chosen. In this case all of the noise sensitive low power grounds should be commoned together around the IC and then a single connection should be made to the power ground (sense resistor ground point).

The second level threshold is intended to protect the power converter by initiating a low duty cycle hiccup mode when abnormally high, fast rising currents occur. During excessive loading, the first level threshold will always be reached and the output characteristic of the converter will be that of a current source but this sustained current level can cause excessive temperatures in the power train especially the output rectifiers. If the second level threshold is reached, the softstart capacitor will be fully discharged, a retry will commence following the discharge detection. The second level threshold will only be reached when a high  $dV/dt$  is present at the current sense pin. The signal must be fast enough to reach the second level threshold before the first threshold detector turns off the driver. This can usually happen for a saturated power inductor or shorted load. Excessive filtering on the CS pin, extremely low value current sense resistor or an inductor that does not saturate with excessive loading may prevent the second level threshold from ever being reached.

**LM5030**

SNVS215D – APRIL 2003 – REVISED NOVEMBER 2015

www.ti.com

**Feature Description (continued)****7.3.5 Oscillator, Shutdown and Sync Capability**

The LM5030 oscillator is set by a single external resistor connected between the RT pin and return. To set a desired oscillator frequency, the necessary RT resistor can be calculated in [Equation 1](#):

$$RT = \frac{(1/F) - 172 \times 10^{-9}}{182 \times 10^{-12}} \quad (1)$$

Each output switches at half the oscillator frequency in a push-pull configuration. The LM5030 can also be synchronized to an external clock. The external clock must be of higher frequency than the free running frequency set by the RT resistor. The clock signal should be capacitively coupled into the RT pin with a 100-pF capacitor. A peak voltage level greater than 3 V with respect to ground is required for detection of the sync pulse. The sync pulse width should be set in the 15- to 150-ns range by the external components. The RT resistor is always required, whether the oscillator is free running or externally synchronized. The voltage at the RT pin is internally regulated to a nominal 2 V.

Locate the RT resistor close to the device and connected directly to the pins of the IC (RT and GND).

**7.3.6 Slope Compensation**

The PWM comparator compares the current sense signal to the voltage derived from the COMP pin. The COMP voltage is set by either the internal error amplifier or an external error amplifier through an optocoupler. At duty cycles greater than 50% (composite of alternating outputs) current mode control circuits are prone to subharmonic oscillation. By adding an additional ramp signal to the current sense ramp signal this condition can be avoided. The LM5030 integrates this slope compensation by buffering the internal oscillator ramp and summing it internally to the current sense (CS) signal. Additional slope compensation may be added by increasing the source impedance of the current sense signal.

**7.3.7 Soft Start and Shutdown**

The soft-start feature allows the converter to gradually reach the initial steady state operating point, thus reducing start-up stresses and surges. An internal 10-μA current source and an external capacitor generate a ramping voltage signal that limits the error amplifier output during start-up. In the event of a second level current limit fault, the soft-start capacitor will be fully discharged which disables the output drivers. When the fault condition is no longer present, the soft-start capacitor is released to ramp and gradually restart the converter. The SS pin can also be used to disable the controller. If the SS pin voltage is pulled down below 0.45 V (nominal) the controller will disable the outputs and enter a low power state.

**7.3.8 OUT1, OUT2, and Time Delay**

The LM5030 provides two alternating outputs, OUT1 and OUT2. The internal gate drivers can each sink 1.5-A peak each. The maximum duty cycle for each output is inherently limited to less than 50%. The typical deadtime between the falling edge of one gate driver output and the rising edge of the other gate driver output is 135 ns.

**7.3.9 Thermal Protection**

Internal thermal-shutdown circuitry is provided to protect the integrated circuit in the event the excessive junction temperature. When activated, typically at 165°C, the controller is forced into a low-power reset state, disabling the output drivers and the bias regulator. This feature is provided to prevent catastrophic failures from accidental device overheating.

## 7.4 Device Functional Modes

The LM5030 is a versatile PWM controller that can be used in the following functional modes:

- The LM5030 provides a complete push-pull current mode controller.
- The LM5030 driver outputs can be configured to drive high side MOSFETs through a gate driver chip to implement half and full bridge topologies.
- The LM5030 can be configured in single ended outputs such as a flyback converter or boost.
- The LM5030 can also operate in conjunction with a high side driver chip to implement a synchronous buck converter.

Details of these circuits can be found in *Versatility of the LM5030 PWM Push-Pull Controller*, [SNVA548](#).

## LM5030

SNVS215D – APRIL 2003 – REVISED NOVEMBER 2015

www.ti.com

## 8 Application and Implementation

### NOTE

Information in the following applications sections is not part of the TI component specification, and TI does not warrant its accuracy or completeness. TI's customers are responsible for determining suitability of components for their purposes. Customers should validate and test their design implementation to confirm system functionality.

### 8.1 Application Information

The LM5030 is a highly integrated PWM controller that contains all of the features necessary for implementing push-pull topology power converters. The device targets DC-DC converter applications with input voltages of up to 100 VDC and output power in the range 15 W to 150 W.

### 8.2 Typical Application

The schematic in [Figure 8](#) shows an example of a 33-W push-pull converter controlled by a LM5030. The operating input range is 36 V to 75 V, and the output voltage is 3.3 V. The output current capability is 10 A. The converter is configured for input current protection with cycle-by-cycle current limit. An auxiliary winding is used to raise the VCC voltage to reduce the controller power dissipation.

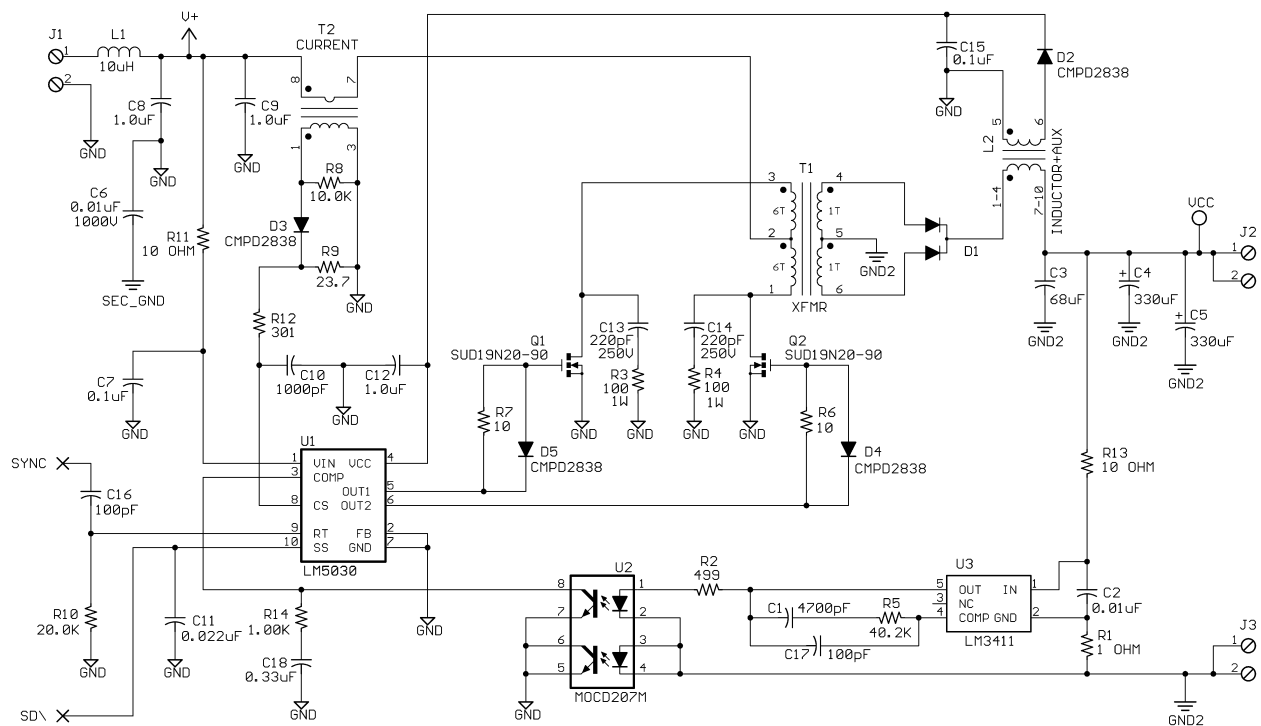

**Figure 8. Typical Application Circuit, 36-V to 75-V IN and 3.3-V, 10-A OUT**

## Typical Application (continued)

### 8.2.1 Design Requirements

For this design example, use the input parameters listed in [Table 1](#).

**Table 1. Design Parameters**

PARAMETER	MIN	NOM	MAX	UNIT
Input Voltage	36		75	V
Output Voltage		3.3		V
Output Current	0		10	A
Efficiency (Full Load)		82.5%		
Efficiency (Half Load)		84.5%		
Load Regulation		1%		
Line Regulation		0.15%		
Output Current Limit		11		A

### 8.2.2 Detailed Design Procedure

#### 8.2.2.1 $V_{CC}$

While the LM5030 internally generates a voltage at  $V_{CC}$  (7.7 V), the internal regulator is used mainly during the start-up sequence. Once the load current begins flowing through L2, which is both an inductor for the output filter and a transformer, a voltage is generated at the secondary of L2, which powers the  $V_{CC}$  pin. When the externally applied voltage exceeds the internal value (7.7 V), the internal regulator shuts off, thereby reducing internal power dissipation in the LM5030. L2 is constructed such that the voltage supplied to  $V_{CC}$  ranges from approximately 10.6 V to approximately 11.3 V, depending on the load current (see [Figure 9](#)).

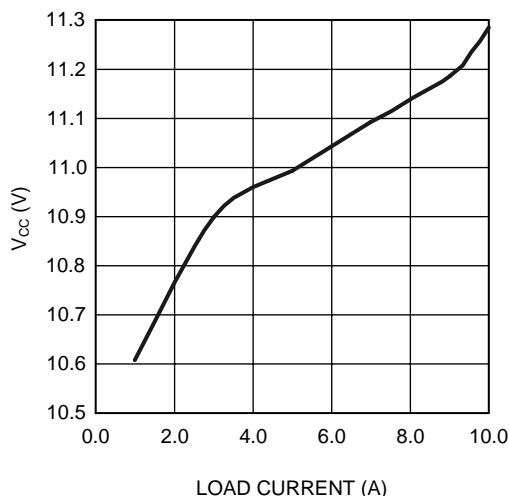

**Figure 9.  $V_{CC}$  Voltage vs Load Current**

#### 8.2.2.2 Current Sense

Monitoring the input current provides a good indication of the operation of the circuit. If an overload condition should exist at the output (a partial overload or a short circuit), the input current would rise above the nominal value shown in [Figure 12](#). Transformer T2, in conjunction with D3, R9, R12 and C10, provides a voltage to pin 8 on the LM5030 (CS) which is representative of the input current flowing through its primary. The average voltage seen at pin 8 is plotted in [Figure 10](#). If the voltage at the first current sense comparator exceeds 0.5 V, the LM5030 disables its outputs, and the circuit enters a cycle-by-cycle current limit mode. If the second level threshold (0.625 V) is exceeded due to a severe overload and transformer saturation, the LM5030 will disable its outputs and initiate a softstart sequence. However, the very short propagation delay of the cycle-by-cycle current limiter (CS1), the design of the CS filter (R9, R12, and C10), and the conservative design of the output inductor (L2), may prevent the second level current threshold from being realized on this evaluation board.

**LM5030**

SNVS215D – APRIL 2003 – REVISED NOVEMBER 2015

www.ti.com

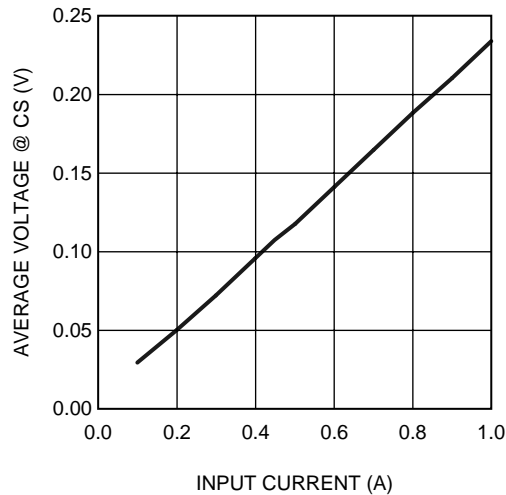
**Figure 10. Average Voltage at the CS Pin vs Input Current****8.2.2.3 Shutdown**

The Shutdown pad (SD) on the board connects to the SoftStart pin on the LM5030 (pin 10), and permits on/off control of the converter by an external switch. SD should be pulled below 0.45 V, with an open collector or open drain device, to shut down the LM5030 outputs and the VCC regulator. If the voltage at the SD pad is between 1.0 and 1.5 V, a partial-on condition results, which could be disruptive to the system. Therefore, the voltage at the SD pad should transition quickly between its open circuit voltage (4.9 V) and ground.

**8.2.2.4 External Sync**

Although the LM5030 includes an internal oscillator, its operating frequency can be synchronized to an external signal if desired. The external source frequency must be higher than the internal frequency set with the RT resistor (262 kHz with  $R_T = 20$  k $\Omega$ ). The sync input pulse width must be between 15 and 150 ns, and have an amplitude of 1.5 to 3.0 V at the Sync pad on the board. The pulses are coupled to the LM5030 through a 100-pF capacitor (C16) as specified in the data sheet.

**Table 2. Bill of Materials**

ITEM	PART NUMBER	DESCRIPTION	VALUE
C 1	C0805C472K5RAC	Capacitor, CER, KEMET	4700 p, 50 V
C 2	C0805C103K5RAC	Capacitor, CER, KEMET	0.01 $\mu$ , 50 V
C 3	C4532X7S0G686M	Capacitor, CER, TDK	68 $\mu$ , 4 V
C 4	T520D337M006AS4350	Capacitor, TANT, KEMET	330 $\mu$ , 6.3 V
C 5	T520D337M006AS4350	Capacitor, TANT, KEMET	330 $\mu$ , 6.3 V
C 6	C4532X7R3A103K	Capacitor, CER, TDK	0.01 $\mu$ , 1000 V
C 7	C3216X7R2A104K	Capacitor, CER, TDK	0.1 $\mu$ , 100 V
C 8	C4532X7R2A105M	Capacitor, CER, TDK	1 $\mu$ , 100 V
C 9	C4532X7R2A105M	Capacitor, CER, TDK	1 $\mu$ , 100 V
C 10	C0805C102K1RAC	Capacitor, CER, KEMET	1000 p, 100 V
C 11	C1206C223K5RAC	Capacitor, CER, KEMET	0.022 $\mu$ , 50 V
C 12	C3216X7R1E105M	Capacitor, CER, TDK	1 $\mu$ , 25 V
C 13	C3216COG2J221J	Capacitor, CER, TDK	220 p, 630 V
C 14	C3216COG2J221J	Capacitor, CER, TDK	220 p, 630 V
C 15	C1206C104K5RAC	Capacitor, CER, KEMET	0.1 $\mu$ , 50 V
C 16	C0805C101J1GAC	Capacitor, CER, KEMET	100 p, 100 V
C 17	C0805C101J1GAC	Capacitor, CER, KEMET	100 p, 100 V
C 18	C3216X7R1H334K	Capacitor, CER, TDK	0.33 $\mu$ , 50 $\mu$

**Table 2. Bill of Materials (continued)**

ITEM		PART NUMBER	DESCRIPTION	VALUE
D	1	MBRB3030CTL	Diode, Schottky, ON	
D	2	CMPD2838-NSA	Diode, Signal, Central	
D	3	CMPD2838-NSA	Diode, Signal, Central	
D	4	CMPD2838-NSA	Diode, Signal, Central	
D	5	CMPD2838-NSA	Diode, Signal, Central	
L	1	MSS6132-103	Input Choke, Coilcraft	10 $\mu$ H, 1.5 A
L	2	A9785-B	Output Choke, Coilcraft	7 $\mu$ H
R	1	CRCW12061R00F	Resistor	1
R	2	CRCW12064990F	Resistor	499
R	3	CRCW2512101J	Resistor	100, 1 W
R	4	CRCW2512101J	Resistor	100, 1 W
R	5	CRCW12064022F	Resistor	40.2K
R	6	CRCW120610R0F	Resistor	10
R	7	CRCW120610R0F	Resistor	10
R	8	CRCW12061002F	Resistor	10K
R	9	CRCW120623R7F	Resistor	23.7
R	10	CRCW12062002F	Resistor	20K
R	11	CRCW120610R0F	Resistor	10
R	12	CRCW12063010F	Resistor	301
R	13	CRCW120610R0F	Resistor	10
R	14	CRCW12061001F	Resistor	1K
TX	1	A9784-B	POWER XFR, COILCRAFT	
TX	2	P8208T	CURRENT XFR, Pulse	100:1
U1	1	LM5030	REGULATOR, TI	
U2	2	MOCD207M	OPTO-COUPLER, QT OPTOELECTRONICS	
U3	3	LM3411AM5-3.3	REFERENCE, TI	
		651-1727010	DUAL TERMINALS, MOUSER	3 per ASSY
X	1	SUD19N20-90	FET, N, 200 V, SILICONIX	
X	2	SUD19N20-90	FET, N, 200 V, SILICONIX	

**LM5030**

SNVS215D – APRIL 2003 – REVISED NOVEMBER 2015

www.ti.com

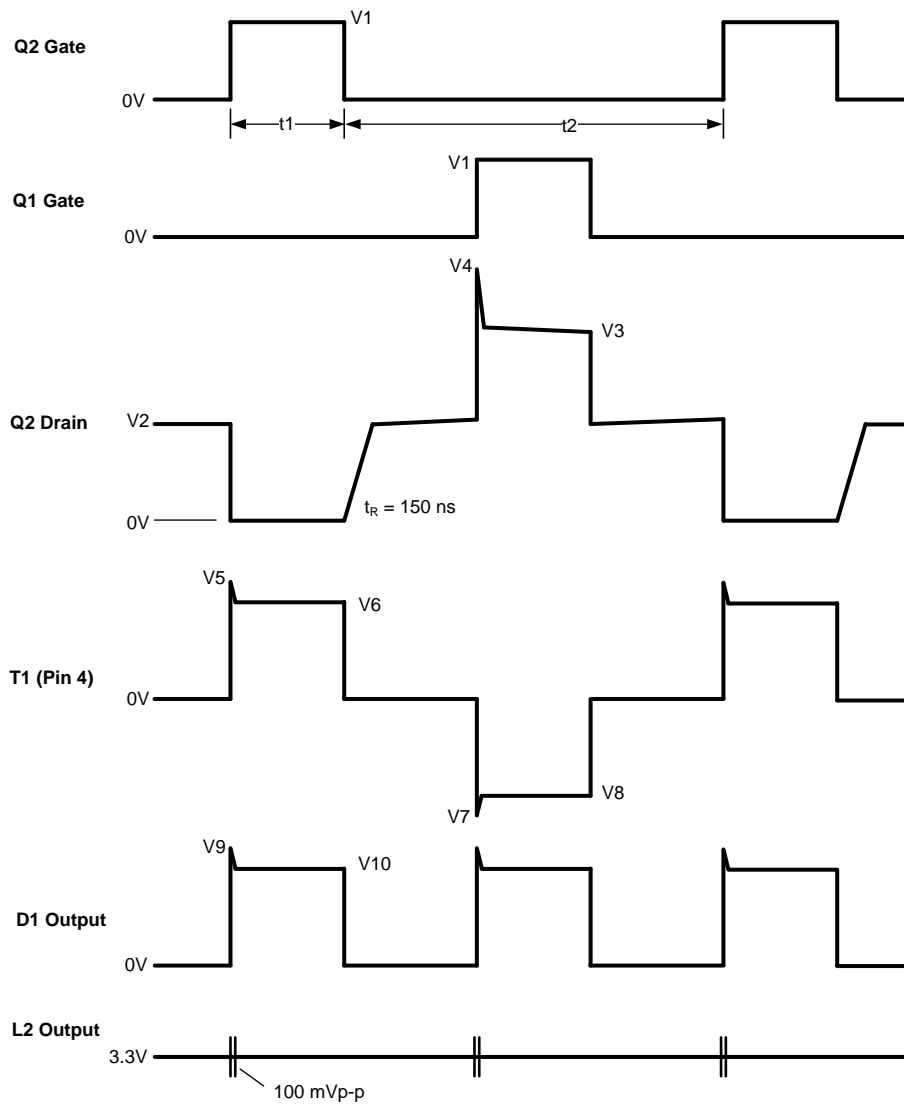
**Figure 11. Representative Waveforms****Table 3. Test Data**

$V_{IN}$	$I_{OUT}$	$t_1$	$t_2$	$F_s$	$V_1$	$V_2$	$V_3$	$V_4$	$V_5$	$V_6$	$V_7$	$V_8$	$V_9$	$V_{10}$
36 V	1.0 A	2.2 $\mu$ S	5.3 $\mu$ S	266.7	10.5 V	36 V	72 V	90 V	10 V	6 V	-10 V	-6 V	10 V	6 V
48 V	10 A	1.9 $\mu$ S	5.5 $\mu$ S	270.3	11.5 V	48 V	96 V	130 V	18 V	8 V	-18 V	-8 V	13 V	8 V
75 V	1.0 A	1.2 $\mu$ S	6.2 $\mu$ S	270.3	10.5 V	75 V	150 V	200 V	20 V	13 V	-20 V	-13 V	20 V	13 V

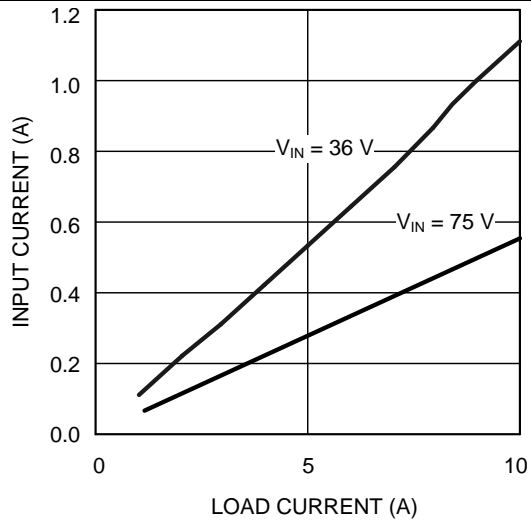
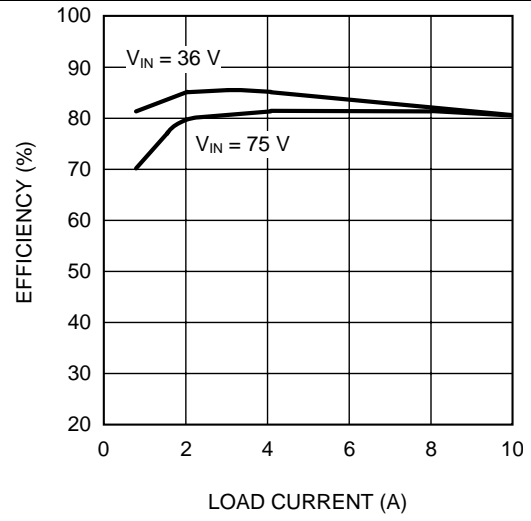
**8.2.3 Application Curves**Figure 12. Input Current vs Load Current and  $V_{IN}$ Figure 13. Efficiency vs Load Current and  $V_{IN}$

## LM5030

SNVS215D – APRIL 2003 – REVISED NOVEMBER 2015

www.ti.com

## 9 Power Supply Recommendations

The LM5030 can be used as a controller for push-pull, full bridge or half bridge power supplies. Typical applications are for input voltages up to 100 V and output power around 30 W with switching frequency up to 1 MHz.

Care should be taken that components with the correct current rating are chosen. This includes magnetic components, power MOSFETs and diodes, connectors and wire sizes. Input and output capacitors should have the correct ripple current rating.

The VCC pin requires a local decoupling capacitor that is connected to GND. This capacitor ensures stability of the internal regulator from the VIN pin. The decoupling capacitor also provides the current pulses to drive the gates of the external MOSFETs through the driver output pins.

Place the decoupling capacitor close to the VCC and GND pins and track it directly to these pins.

## 10 Layout

### 10.1 Layout Guidelines

As in all high frequency switching power supplies, it is important to separate the high current return trace from the low level GND signal of the controller. These signals should be connected together at a single point, usually the negative side of the DC input filter capacitor.

Layout considerations are critical for the current sense filter. If a current sense transformer is used, both leads of the transformer secondary should be routed to the sense filter components and to the device pins. If the current sense circuit employs a sense resistor in the power MOSFET source, a low inductance resistor should be used and all the low current traces should be connected in common near the device with a single connection made to the GND pin.

The gate drive outputs of the device should have short, direct paths to the power MOSFETs in order to minimize inductance in the gate path.

If the internal dissipation of the device produces a high junction temperature during normal operation, the use of multiple vias under the device to a ground plane can help conduct heat away from the device.

### 10.2 Layout Example

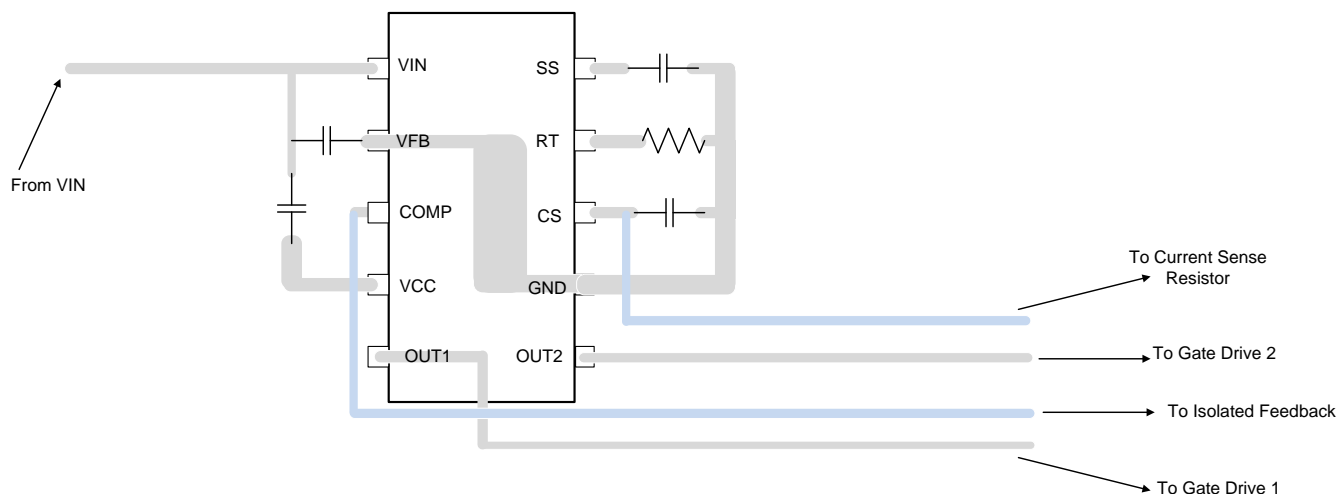

**Figure 14. LM5030 Board Layout**

## 11 Device and Documentation Support

### 11.1 Device Support

#### 11.1.1 Third-Party Products Disclaimer

TI'S PUBLICATION OF INFORMATION REGARDING THIRD-PARTY PRODUCTS OR SERVICES DOES NOT CONSTITUTE AN ENDORSEMENT REGARDING THE SUITABILITY OF SUCH PRODUCTS OR SERVICES OR A WARRANTY, REPRESENTATION OR ENDORSEMENT OF SUCH PRODUCTS OR SERVICES, EITHER ALONE OR IN COMBINATION WITH ANY TI PRODUCT OR SERVICE.

### 11.2 Documentation Support

#### 11.2.1 Related Documentation

[SNOA401](#): *AN-1187 Leadless Leadframe Package (LLP)*

[SNVA548](#): *Versatility of the LM5030 PWM Push-Pull Controller*

### 11.3 Community Resources

The following links connect to TI community resources. Linked contents are provided "AS IS" by the respective contributors. They do not constitute TI specifications and do not necessarily reflect TI's views; see TI's [Terms of Use](#).

**TI E2E™ Online Community** *TI's Engineer-to-Engineer (E2E) Community*. Created to foster collaboration among engineers. At [e2e.ti.com](#), you can ask questions, share knowledge, explore ideas and help solve problems with fellow engineers.

**Design Support** *TI's Design Support* Quickly find helpful E2E forums along with design support tools and contact information for technical support.

### 11.4 Trademarks

E2E is a trademark of Texas Instruments.  
All other trademarks are the property of their respective owners.

### 11.5 Electrostatic Discharge Caution



These devices have limited built-in ESD protection. The leads should be shorted together or the device placed in conductive foam during storage or handling to prevent electrostatic damage to the MOS gates.

### 11.6 Glossary

[SLYZ022](#) — *TI Glossary*.

This glossary lists and explains terms, acronyms, and definitions.

## 12 Mechanical, Packaging, and Orderable Information

The following pages include mechanical, packaging, and orderable information. This information is the most current data available for the designated devices. This data is subject to change without notice and revision of this document. For browser-based versions of this data sheet, refer to the left-hand navigation.

**PACKAGING INFORMATION**

Orderable part number	Status (1)	Material type (2)	Package   Pins	Package qty   Carrier	RoHS (3)	Lead finish/ Ball material (4)	MSL rating/ Peak reflow (5)	Op temp (°C)	Part marking (6)
<a href="#">LM5030MM/NOPB</a>	Obsolete	Production	VSSOP (DGS)   10	-	-	Call TI	Call TI	-40 to 125	S73B
<a href="#">LM5030MMX/NOPB</a>	Active	Production	VSSOP (DGS)   10	3500   LARGE T&R	Yes	SN	Level-1-260C-UNLIM	-40 to 125	S73B
LM5030MMX/NOPB.A	Active	Production	VSSOP (DGS)   10	3500   LARGE T&R	Yes	SN	Level-1-260C-UNLIM	-40 to 125	S73B
LM5030MMX/NOPB.B	Active	Production	VSSOP (DGS)   10	3500   LARGE T&R	Yes	SN	Level-1-260C-UNLIM	-40 to 125	S73B
<a href="#">LM5030SD/NOPB</a>	Active	Production	WSON (DPR)   10	1000   LARGE T&R	Yes	SN	Level-1-260C-UNLIM	-40 to 125	5030SD
LM5030SD/NOPB.A	Active	Production	WSON (DPR)   10	1000   LARGE T&R	Yes	SN	Level-1-260C-UNLIM	-40 to 125	5030SD
LM5030SD/NOPB.B	Active	Production	WSON (DPR)   10	1000   LARGE T&R	Yes	SN	Level-1-260C-UNLIM	-40 to 125	5030SD

(1) **Status:** For more details on status, see our [product life cycle](#).

(2) **Material type:** When designated, preproduction parts are prototypes/experimental devices, and are not yet approved or released for full production. Testing and final process, including without limitation quality assurance, reliability performance testing, and/or process qualification, may not yet be complete, and this item is subject to further changes or possible discontinuation. If available for ordering, purchases will be subject to an additional waiver at checkout, and are intended for early internal evaluation purposes only. These items are sold without warranties of any kind.

(3) **RoHS values:** Yes, No, RoHS Exempt. See the [TI RoHS Statement](#) for additional information and value definition.

(4) **Lead finish/Ball material:** Parts may have multiple material finish options. Finish options are separated by a vertical ruled line. Lead finish/Ball material values may wrap to two lines if the finish value exceeds the maximum column width.

(5) **MSL rating/Peak reflow:** The moisture sensitivity level ratings and peak solder (reflow) temperatures. In the event that a part has multiple moisture sensitivity ratings, only the lowest level per JEDEC standards is shown. Refer to the shipping label for the actual reflow temperature that will be used to mount the part to the printed circuit board.

(6) **Part marking:** There may be an additional marking, which relates to the logo, the lot trace code information, or the environmental category of the part.

Multiple part markings will be inside parentheses. Only one part marking contained in parentheses and separated by a "-" will appear on a part. If a line is indented then it is a continuation of the previous line and the two combined represent the entire part marking for that device.

**Important Information and Disclaimer:** The information provided on this page represents TI's knowledge and belief as of the date that it is provided. TI bases its knowledge and belief on information provided by third parties, and makes no representation or warranty as to the accuracy of such information. Efforts are underway to better integrate information from third parties. TI has taken and continues to take reasonable steps to provide representative and accurate information but may not have conducted destructive testing or chemical analysis on incoming materials and chemicals. TI and TI suppliers consider certain information to be proprietary, and thus CAS numbers and other limited information may not be available for release.

In no event shall TI's liability arising out of such information exceed the total purchase price of the TI part(s) at issue in this document sold by TI to Customer on an annual basis.



## TAPE AND REEL INFORMATION

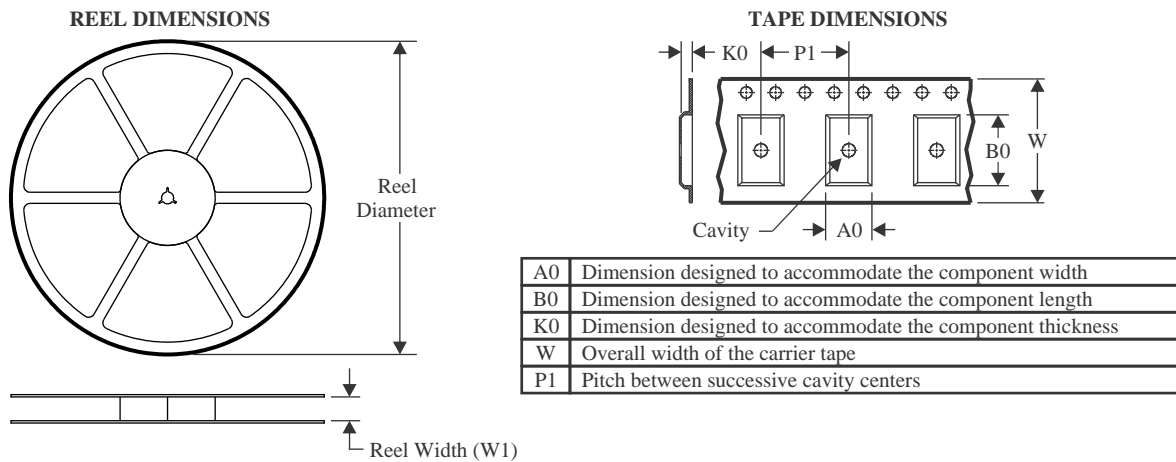

### QUADRANT ASSIGNMENTS FOR PIN 1 ORIENTATION IN TAPE

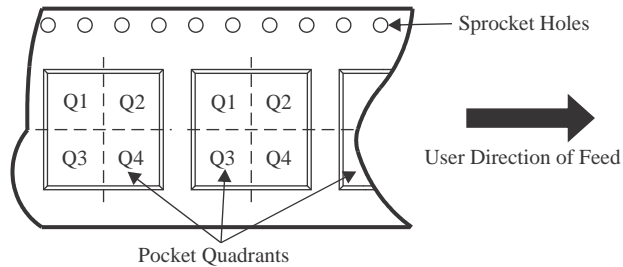

\*All dimensions are nominal

Device	Package Type	Package Drawing	Pins	SPQ	Reel Diameter (mm)	Reel Width W1 (mm)	A0 (mm)	B0 (mm)	K0 (mm)	P1 (mm)	W (mm)	Pin1 Quadrant
LM5030MMX/NOPB	VSSOP	DGS	10	3500	330.0	12.4	5.3	3.4	1.4	8.0	12.0	Q1
LM5030SD/NOPB	WSOP	DPR	10	1000	177.8	12.4	4.3	4.3	1.3	8.0	12.0	Q1

## TAPE AND REEL BOX DIMENSIONS

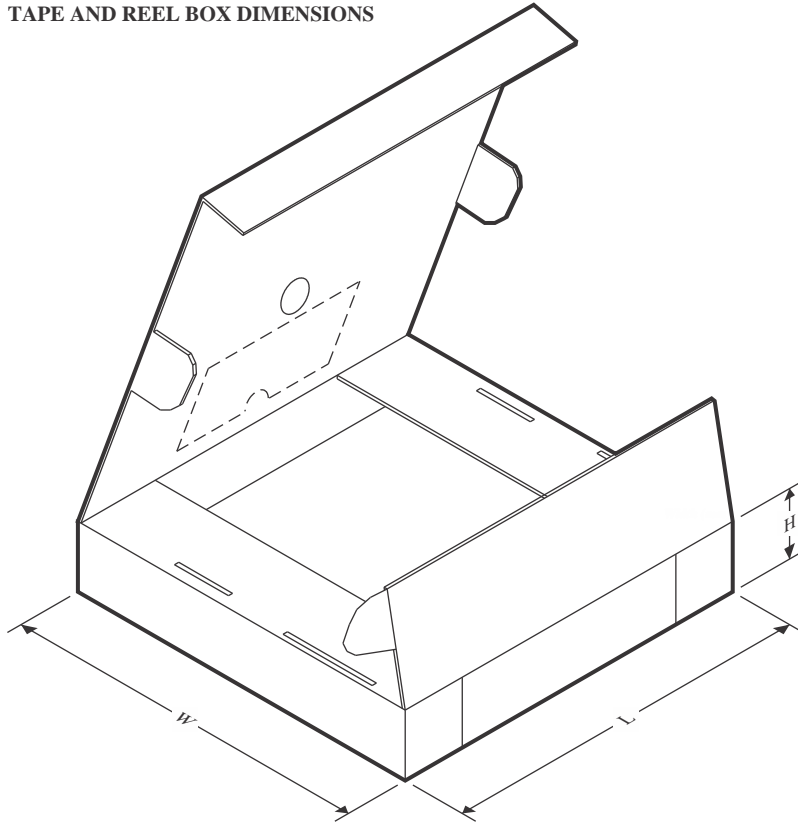

\*All dimensions are nominal

Device	Package Type	Package Drawing	Pins	SPQ	Length (mm)	Width (mm)	Height (mm)
LM5030MMX/NOPB	VSSOP	DGS	10	3500	367.0	367.0	35.0
LM5030SD/NOPB	WSON	DPR	10	1000	208.0	191.0	35.0



## DGS0010A

## PACKAGE OUTLINE

VSSOP - 1.1 mm max height

SMALL OUTLINE PACKAGE

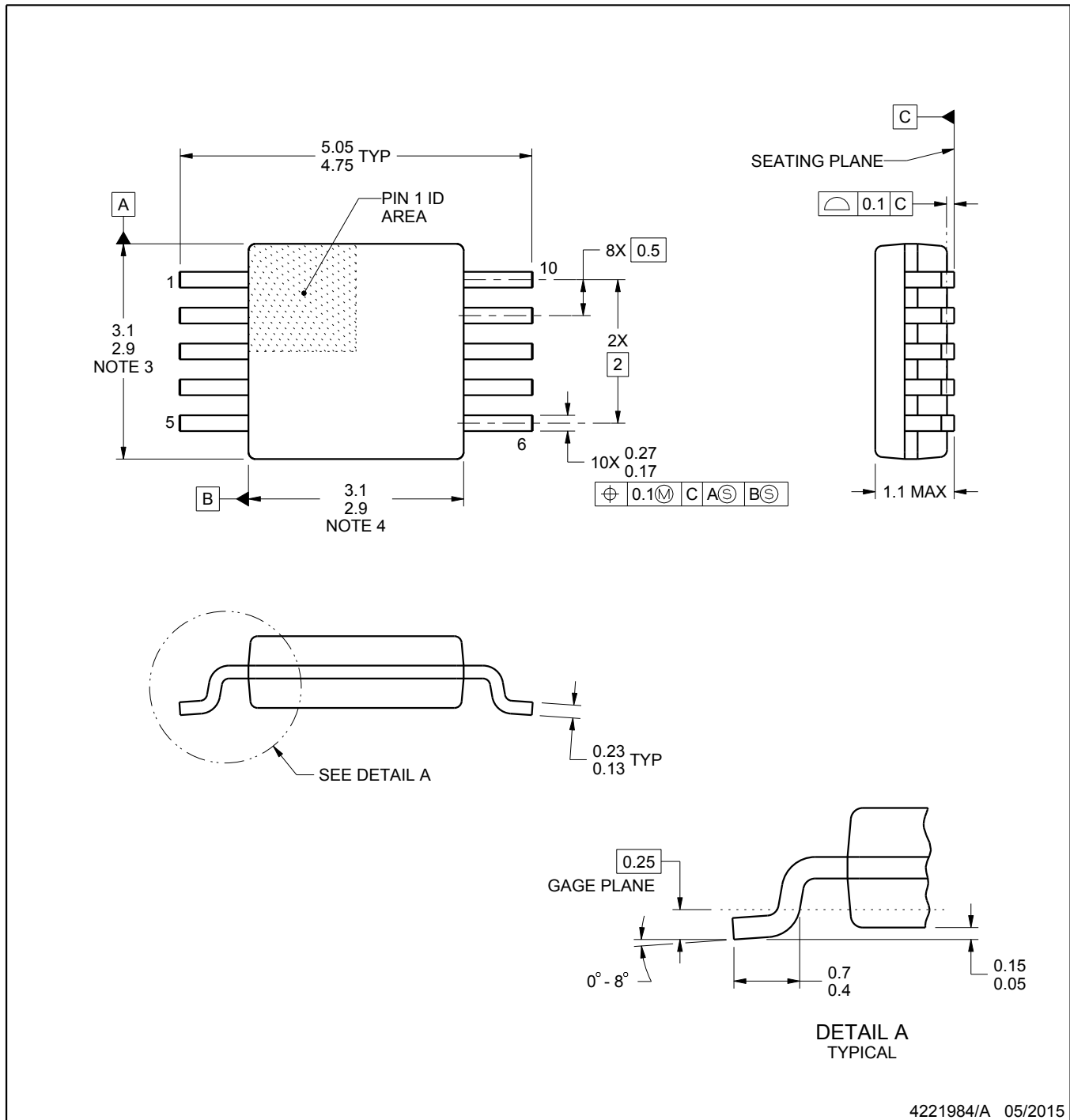

## NOTES:

1. All linear dimensions are in millimeters. Any dimensions in parenthesis are for reference only. Dimensioning and tolerancing per ASME Y14.5M.
2. This drawing is subject to change without notice.
3. This dimension does not include mold flash, protrusions, or gate burrs. Mold flash, protrusions, or gate burrs shall not exceed 0.15 mm per side.
4. This dimension does not include interlead flash. Interlead flash shall not exceed 0.25 mm per side.
5. Reference JEDEC registration MO-187, variation BA.

**EXAMPLE BOARD LAYOUT****DGS0010A****VSSOP - 1.1 mm max height**

SMALL OUTLINE PACKAGE

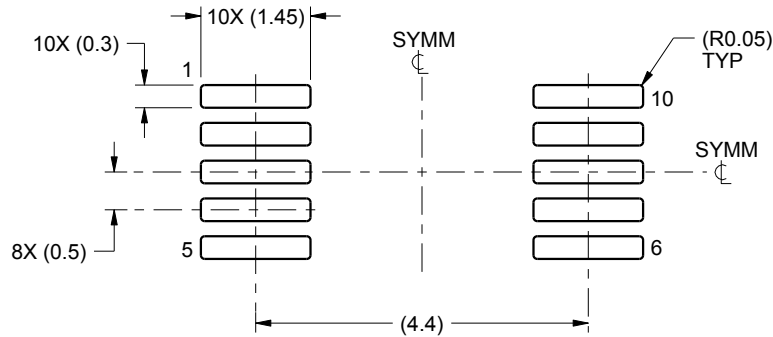

LAND PATTERN EXAMPLE  
SCALE:10X

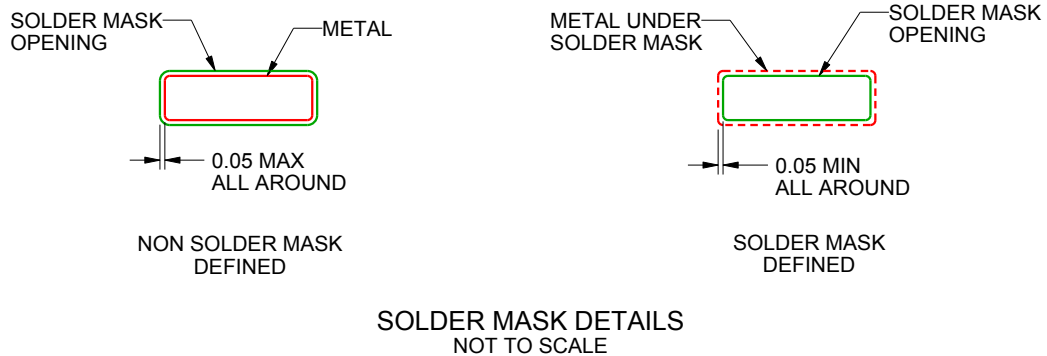

4221984/A 05/2015

NOTES: (continued)

6. Publication IPC-7351 may have alternate designs.
7. Solder mask tolerances between and around signal pads can vary based on board fabrication site.

**EXAMPLE STENCIL DESIGN****DGS0010A****VSSOP - 1.1 mm max height**

SMALL OUTLINE PACKAGE

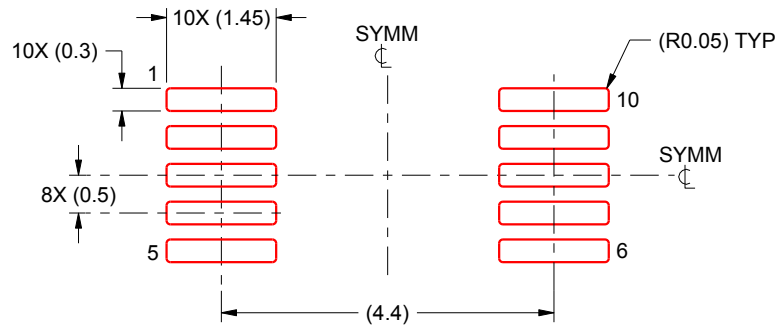

SOLDER PASTE EXAMPLE  
 BASED ON 0.125 mm THICK STENCIL  
 SCALE:10X

4221984/A 05/2015

NOTES: (continued)

8. Laser cutting apertures with trapezoidal walls and rounded corners may offer better paste release. IPC-7525 may have alternate design recommendations.
9. Board assembly site may have different recommendations for stencil design.

**GENERIC PACKAGE VIEW****DPR 10****WSO - 0.8 mm max height**

4 x 4, 0.8 mm pitch

PLASTIC SMALL OUTLINE - NO LEAD

This image is a representation of the package family, actual package may vary.  
Refer to the product data sheet for package details.

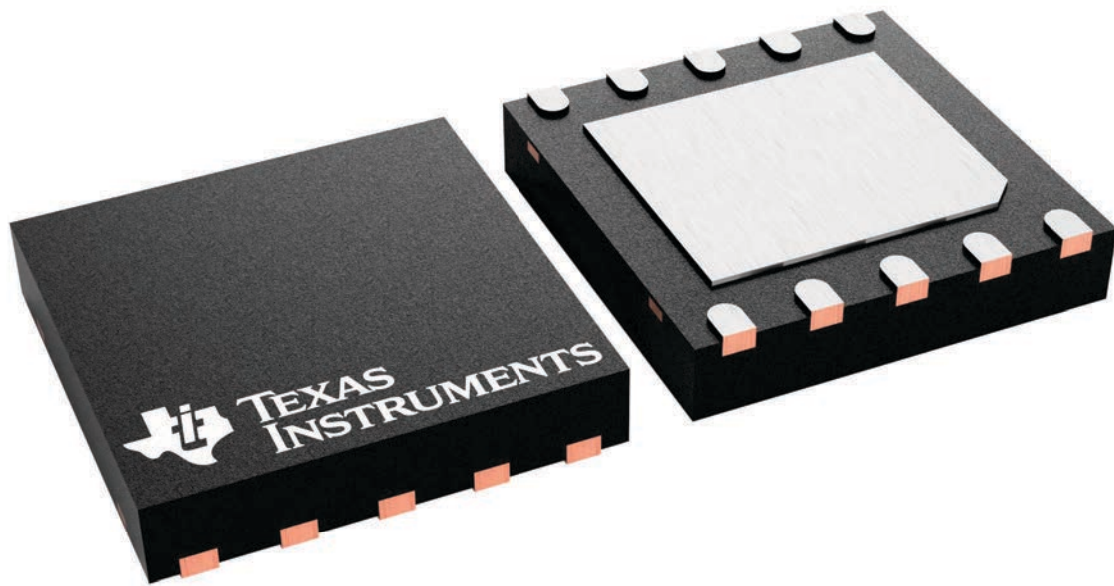

## IMPORTANT NOTICE AND DISCLAIMER

TI PROVIDES TECHNICAL AND RELIABILITY DATA (INCLUDING DATASHEETS), DESIGN RESOURCES (INCLUDING REFERENCE DESIGNS), APPLICATION OR OTHER DESIGN ADVICE, WEB TOOLS, SAFETY INFORMATION, AND OTHER RESOURCES "AS IS" AND WITH ALL FAULTS, AND DISCLAIMS ALL WARRANTIES, EXPRESS AND IMPLIED, INCLUDING WITHOUT LIMITATION ANY IMPLIED WARRANTIES OF MERCHANTABILITY, FITNESS FOR A PARTICULAR PURPOSE OR NON-INFRINGEMENT OF THIRD PARTY INTELLECTUAL PROPERTY RIGHTS.

These resources are intended for skilled developers designing with TI products. You are solely responsible for (1) selecting the appropriate TI products for your application, (2) designing, validating and testing your application, and (3) ensuring your application meets applicable standards, and any other safety, security, regulatory or other requirements.

These resources are subject to change without notice. TI grants you permission to use these resources only for development of an application that uses the TI products described in the resource. Other reproduction and display of these resources is prohibited. No license is granted to any other TI intellectual property right or to any third party intellectual property right. TI disclaims responsibility for, and you fully indemnify TI and its representatives against any claims, damages, costs, losses, and liabilities arising out of your use of these resources.

TI's products are provided subject to [TI's Terms of Sale](#), [TI's General Quality Guidelines](#), or other applicable terms available either on [ti.com](http://ti.com) or provided in conjunction with such TI products. TI's provision of these resources does not expand or otherwise alter TI's applicable warranties or warranty disclaimers for TI products. Unless TI explicitly designates a product as custom or customer-specified, TI products are standard, catalog, general purpose devices.

TI objects to and rejects any additional or different terms you may propose.

Copyright © 2025, Texas Instruments Incorporated

Last updated 10/2025

## OUR CERTIFICATE

DiGi provide top-quality products and perfect service for customer worldwide through standardization, technological innovation and continuous improvement. DiGi through third-party certification, we stricly control the quality of products and services. Welcome your RFQ to

Email: [Info@DiGi-Electronics.com](mailto:Info@DiGi-Electronics.com)



Tel: +00 852-30501935

RFQ Email: [Info@DiGi-Electronics.com](mailto:Info@DiGi-Electronics.com)

DiGi is a global authorized distributor of electronic components.