

LMD18245T Datasheet

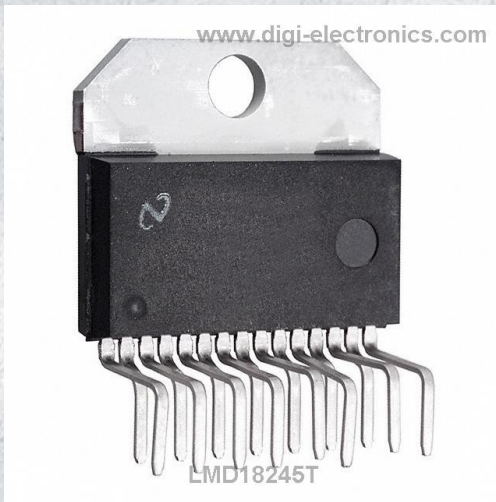

<https://www.DiGi-Electronics.com>

DiGi Electronics Part Number	LMD18245T-DG
Manufacturer	Texas Instruments
Manufacturer Product Number	LMD18245T
Description	IC MTR DRV BIPLR 12-55V TO220-15
Detailed Description	Bipolar Motor Driver Bi-CMOS, DMOS Parallel TO-220-15



Tel: +00 852-30501935

RFQ Email: Info@DiGi-Electronics.com

DiGi is a global authorized distributor of electronic components.

Purchase and inquiry

Manufacturer Product Number:

LMD18245T

Series:

-

Motor Type - Stepper:

Bipolar

Function:

Driver - Fully Integrated, Control and Power Stage

Interface:

Parallel

Step Resolution:

1, 1/2

Current - Output:

3A

Voltage - Load:

12V ~ 55V

Mounting Type:

Through Hole

Supplier Device Package:

TO-220-15

Manufacturer:

Texas Instruments

Product Status:

Not For New Designs

Motor Type - AC, DC:

Brushed DC

Output Configuration:

Half Bridge (2)

Technology:

Bi-CMOS, DMOS

Applications:

General Purpose

Voltage - Supply:

12V ~ 55V

Operating Temperature:

-40°C ~ 150°C (TJ)

Package / Case:

TO-220-15 Formed Leads

Base Product Number:

LMD18245

Environmental & Export classification

RoHS Status:

ROHS3 Compliant

REACH Status:

REACH Unaffected

HTSUS:

8542.39.0001

Moisture Sensitivity Level (MSL):

1 (Unlimited)

ECCN:

EAR99

LMD18245 3A, 55V DMOS Full-Bridge Motor Driver

Check for Samples: [LMD18245](#)

FEATURES

- **DMOS Power Stage Rated at 55V and 3A Continuous**
- **Low $R_{DS(ON)}$ of Typically 0.3Ω per Power Switch**
- **Internal Clamp Diodes**
- **Low-loss Current Sensing Method**
- **Digital or Analog Control of Motor Current**
- **TTL and CMOS Compatible Inputs**
- **Thermal Shutdown (Outputs Off) at $T_J = 155^\circ\text{C}$**
- **Overcurrent Protection**
- **No Shoot-Through Currents**
- **15-lead Package**

APPLICATIONS

- **Full, Half and Microstep Stepper Motor Drives**
- **Stepper Motor and Brushed DC Motor Servo Drives**
- **Automated Factory, Medical and Office Equipment**

DESCRIPTION

The LMD18245 full-bridge power amplifier incorporates all the circuit blocks required to drive and control current in a brushed type DC motor or one phase of a bipolar stepper motor. The multi-technology process used to build the device combines bipolar and CMOS control and protection circuitry with DMOS power switches on the same monolithic structure. The LMD18245 controls the motor current via a fixed off-time chopper technique.

An all DMOS H-bridge power stage delivers continuous output currents up to 3A (6A peak) at supply voltages up to 55V. The DMOS power switches feature low $R_{DS(ON)}$ for high efficiency, and a diode intrinsic to the DMOS body structure eliminates the discrete diodes typically required to clamp bipolar power stages.

An innovative current sensing method eliminates the power loss associated with a sense resistor in series with the motor. A four-bit digital-to-analog converter (DAC) provides a digital path for controlling the motor current, and, by extension, simplifies implementation of full, half and microstep stepper motor drives. For higher resolution applications, an external DAC can be used.



Please be aware that an important notice concerning availability, standard warranty, and use in critical applications of Texas Instruments semiconductor products and disclaimers thereto appears at the end of this data sheet.

All trademarks are the property of their respective owners.

Functional Block and Connection Diagram

15-Lead TO-220 Power Package (NDL)

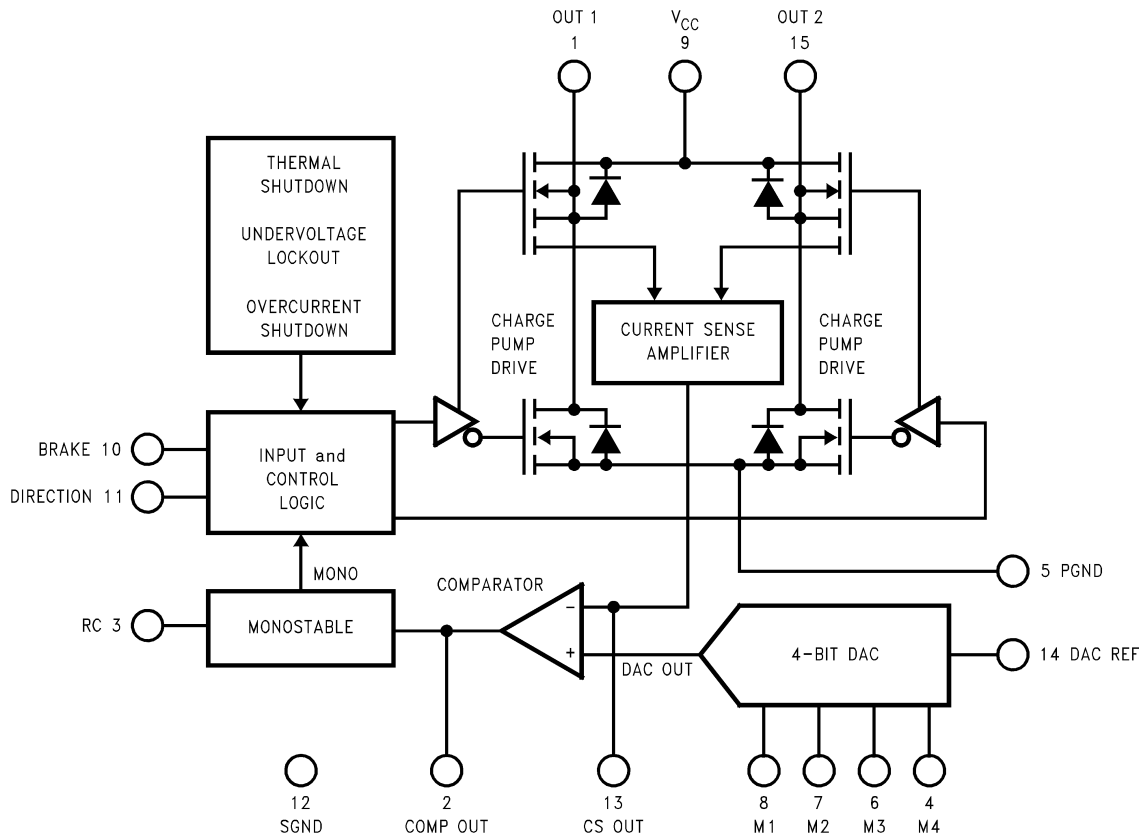

Figure 1. Functional Block Diagram

Connection Diagram

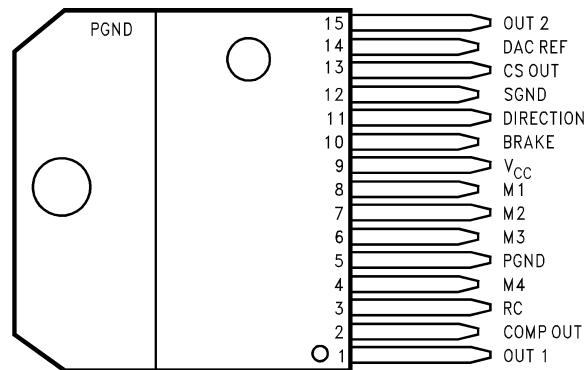

Figure 2. Top View
15-Lead Package TO-220 Power Package
See Package Number NDL0015A

Pinout Descriptions

(See Functional Block and Connection Diagrams)

Pin 1, OUT 1: Output node of the first half H-bridge.

Pin 2, COMP OUT: Output of the comparator. If the voltage at CS OUT exceeds that provided by the DAC, the comparator triggers the monostable.

Pin 3, RC: Monostable timing node. A parallel resistor/capacitor network connected between this node and ground sets the monostable timing pulse at about 1.1 RC seconds.

Pin 5, PGND: Ground return node of the power bridge. Bond wires (internal) connect PGND to the tab of the TO-220 package.

Pins 4 and 6 through 8, M4 through M1: Digital inputs of the DAC. These inputs make up a four-bit binary number with M4 as the most significant bit or MSB. The DAC provides an analog voltage directly proportional to the binary number applied at M4 through M1.

Pin 9, V_{CC}: Power supply node.

Pin 10, BRAKE: Brake logic input. Pulling the BRAKE input logic-high activates both sourcing switches of the power bridge — effectively shorting the load. See [SWITCH CONTROL LOGIC TRUTH TABLE^{\(1\)}](#). Shorting the load in this manner forces the load current to recirculate and decay to zero.

Pin 11, DIRECTION: Direction logic input. The logic level at this input dictates the direction of current flow in the load. See [SWITCH CONTROL LOGIC TRUTH TABLE^{\(1\)}](#).

Pin 12, SGND: Ground return node of all signal level circuits.

Pin 13, CS OUT: Output of the current sense amplifier. The current sense amplifier sources 250 μ A (typical) per ampere of total forward current conducted by the upper two switches of the power bridge.

Pin 14, DAC REF: Voltage reference input of the DAC. The DAC provides an analog voltage equal to $V_{DAC\ REF} \times D/16$, where D is the decimal equivalent (0–15) of the binary number applied at M4 through M1.

Pin 15, OUT 2: Output node of the second half H-bridge.

SWITCH CONTROL LOGIC TRUTH TABLE⁽¹⁾

BRAKE	DIRECTION	MONO	Active Switches
H	X	X	Source 1, Source 2
L	H	L	Source 2
L	H	H	Source 2, Sink 1
L	L	L	Source 1
L	L	H	Source 1, Sink 2

(1) X = don't care. MONO is the output of the monostable.

(1) X = don't care. MONO is the output of the monostable.



These devices have limited built-in ESD protection. The leads should be shorted together or the device placed in conductive foam during storage or handling to prevent electrostatic damage to the MOS gates.

Absolute Maximum Ratings ⁽¹⁾⁽²⁾

DC Voltage at:	
OUT 1, V _{CC} , and OUT 2	+60V
COMP OUT, RC, M4, M3, M2, M1, BRAKE, DIRECTION, CS OUT, and DAC REF	+12V
DC Voltage PGND to SGND	±400mV
Continuous Load Current	3A
Peak Load Current ⁽³⁾	6A
Junction Temperature (T _{J(max)})	+150°C
Power Dissipation ⁽⁴⁾ :	
TO-220 (T _A = 25°C, Infinite Heatsink)	25W
TO-220 (T _A = 25°C, Free Air)	3.5W
ESD Susceptibility ⁽⁵⁾	1500V
Storage Temperature Range (T _S)	-40°C to +150°C
Lead Temperature (Soldering, 10 seconds)	300°C

- (1) Absolute Maximum Ratings indicate limits beyond which damage to the device may occur. Electrical specifications do not apply when operating the device outside the rated Operating Conditions.
- (2) If Military/Aerospace specified devices are required, please contact the Texas Instruments Sales Office/ Distributors for availability and specifications.
- (3) Unless otherwise stated, load currents are pulses with widths less than 2 ms and duty cycles less than 5%.
- (4) The maximum allowable power dissipation at any ambient temperature is $P_{Max} = (125 - T_A)/\theta_{JA}$, where 125°C is the maximum junction temperature for operation, T_A is the ambient temperature in °C, and θ_{JA} is the junction-to-ambient thermal resistance in °C/W. Exceeding P_{max} voids the Electrical Specifications by forcing T_J above 125°C. If the junction temperature exceeds 155°C, internal circuitry disables the power bridge. When a heatsink is used, θ_{JA} is the sum of the junction-to-case thermal resistance of the package, θ_{JC} , and the case-to-ambient thermal resistance of the heatsink.
- (5) ESD rating is based on the human body model of 100 pF discharged through a 1.5 kΩ resistor. M1, M2, M3 and M4, pins 8, 7, 6 and 4 are protected to 800V.

Operating Conditions ⁽¹⁾

Temperature Range (T _J) ⁽²⁾	-40°C to +125°C
Supply Voltage Range (V _{CC})	+12V to +55V
CS OUT Voltage Range	0V to +5V
DAC REF Voltage Range	0V to +5V
MONOSTABLE Pulse Range	10 μs to 100 ms

- (1) Absolute Maximum Ratings indicate limits beyond which damage to the device may occur. Electrical specifications do not apply when operating the device outside the rated Operating Conditions.
- (2) The maximum allowable power dissipation at any ambient temperature is $P_{Max} = (125 - T_A)/\theta_{JA}$, where 125°C is the maximum junction temperature for operation, T_A is the ambient temperature in °C, and θ_{JA} is the junction-to-ambient thermal resistance in °C/W. Exceeding P_{max} voids the Electrical Specifications by forcing T_J above 125°C. If the junction temperature exceeds 155°C, internal circuitry disables the power bridge. When a heatsink is used, θ_{JA} is the sum of the junction-to-case thermal resistance of the package, θ_{JC} , and the case-to-ambient thermal resistance of the heatsink.

Electrical Characteristics ⁽¹⁾

The following specifications apply for $V_{CC} = +42V$, unless otherwise stated. **Boldface limits apply over the operating temperature range, $-40^{\circ}C \leq T_J \leq +125^{\circ}C$.** All other limits apply for $T_A = T_J = 25^{\circ}C$.

Symbol	Parameter	Conditions	Typical ⁽²⁾	Limit ⁽²⁾	Units (Limits)
I_{CC}	Quiescent Supply Current	DAC REF = 0V, $V_{CC} = +20V$	8	15	mA mA (max)
POWER OUTPUT STAGE					
$R_{DS(ON)}$	Switch ON Resistance	$I_{LOAD} = 3A$	0.3	0.4	Ω (max)
		$I_{LOAD} = 6A$	0.3	0.6 0.4 0.6	Ω (max) Ω (max) Ω (max)
V_{DIODE}	Body Diode Forward Voltage	$I_{DIODE} = 3A$	1.0	1.5	V V(max)
T_{rr}	Diode Reverse Recovery Time	$I_{DIODE} = 1A$	80		ns
Q_{rr}	Diode Reverse Recovery Charge	$I_{DIODE} = 1A$	40		nC
$t_{D(ON)}$	Output Turn ON Delay Time	Sourcing Outputs $I_{LOAD} = 3A$	5		μs
		Sinking Outputs $I_{LOAD} = 3A$	900		ns
$t_{D(OFF)}$	Output Turn OFF Delay Time	Sourcing Outputs $I_{LOAD} = 3A$	600		ns
		Sinking Outputs $I_{LOAD} = 3A$	400		ns
t_{ON}	Output Turn ON Switching Time	Sourcing Outputs $I_{LOAD} = 3A$	40		μs
		Sinking Outputs $I_{LOAD} = 3A$	1		μs
t_{OFF}	Output Turn OFF Switching Time	Sourcing Outputs $I_{LOAD} = 3A$	200		ns
		Sinking Outputs $I_{LOAD} = 3A$	80		ns
t_{pw}	Minimum Input Pulse Width	Pins 10 and 11	2		μs
t_{DB}	Minimum Dead Band	⁽³⁾	40		ns
CURRENT SENSE AMPLIFIER					
	Current Sense Output	$I_{LOAD} = 1A$ ⁽⁴⁾	250	200	μA (min)
				175	μA (min)
				300	μA (max)
				325	μA (max)
	Current Sense Linearity Error	$0.5A \leq I_{LOAD} \leq 3A$ ⁽⁴⁾	± 6	± 9	%
					%(max)
	Current Sense Offset	$I_{LOAD} = 0A$	5	20	μA
					μA (max)

- (1) Unless otherwise stated, load currents are pulses with widths less than 2 ms and duty cycles less than 5%.
- (2) All limits are 100% production tested at 25°C. Temperature extreme limits are ensured via correlation using accepted SQC (Statistical Quality Control) methods. All limits are used to calculate AOQL (Average Outgoing Quality Level). Typical values are at $T_J = 25^{\circ}C$ and represent the most likely parametric norm.
- (3) Asymmetric turn OFF and ON delay times and switching times ensure a switch turns OFF before the other switch in the same half H-bridge begins to turn ON (preventing momentary short circuits between the power supply and ground). The transitional period during which both switches are OFF is commonly referred to as the dead band.
- (4) (I_{LOAD} , I_{SENSE}) data points are taken for load currents of 0.5A, 1A, 2A and 3A. The current sense gain is specified as I_{SENSE}/I_{LOAD} for the 1A data point. The current sense linearity is specified as the slope of the line between the 0.5A and 1A data points minus the slope of the line between the 2A and 3A data points all divided by the slope of the line between the 0.5A and 1A data points.

Electrical Characteristics ⁽¹⁾ (continued)

The following specifications apply for $V_{CC} = +42V$, unless otherwise stated. **Boldface limits apply over the operating temperature range, $-40^{\circ}C \leq T_J \leq +125^{\circ}C$.** All other limits apply for $T_A = T_J = 25^{\circ}C$.

Symbol	Parameter	Conditions	Typical ⁽²⁾	Limit ⁽²⁾	Units (Limits)
DIGITAL-TO-ANALOG CONVERTER (DAC)					
	Resolution			4	Bits (min)
	Monotonicity			4	Bits (min)
	Total Unadjusted Error		0.125	0.25 0.5	LSB (max) LSB (max)
	Propagation Delay		50		ns
I_{REF}	DAC REF Input Current	DAC REF = +5V	-0.5	± 10	μA μA (max)
COMPARATOR AND MONOSTABLE					
	Comparator High Output Level		6.27		V
	Comparator Low Output Level		88		mV
	Comparator Output Current Source		0.2		mA
	Sink		3.2		mA
t_{DELAY}	Monostable Turn OFF Delay	⁽⁵⁾	1.2	2.0	μs μs (max)
PROTECTION AND PACKAGE THERMAL RESISTANCES					
	Undervoltage Lockout, V_{CC}			5 8	V (min) V (max)
T_{JSD}	Shutdown Temperature, T_J Package Thermal Resistances		155		$^{\circ}C$
θ_{JC}	Junction-to-Case, TO-220		1.5		$^{\circ}C/W$
θ_{JA}	Junction-to-Ambient, TO-220		35		$^{\circ}C/W$
LOGIC INPUTS					
V_{IL}	Low Level Input Voltage			-0.1 0.8	V (min) V (max)
V_{IH}	High Level Input Voltage			2 12	V (min) V (max)
I_{IN}	Input Current	$V_{IN} = 0V$ or $12V$		± 10	μA (max)

- (5) Turn OFF delay, t_{DELAY} , is defined as the time from the voltage at the output of the current sense amplifier reaching the DAC output voltage to the lower DMOS switch beginning to turn OFF. With $V_{CC} = 32V$, DIRECTION high, and 200Ω connected between OUT1 and V_{CC} , the voltage at RC is increased from 0V to 5V at $1.2V/\mu s$, and t_{DELAY} is measured as the time from the voltage at RC reaching 2V to the time the voltage at OUT 1 reaches 3V.

Typical Performance Characteristics

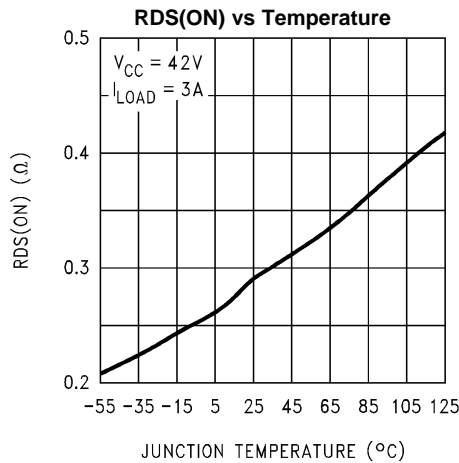

Figure 3.

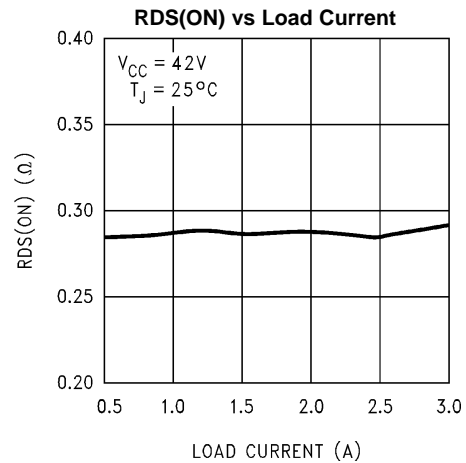

Figure 4.

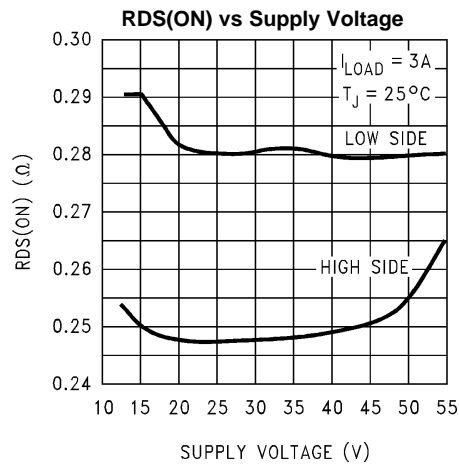

Figure 5.

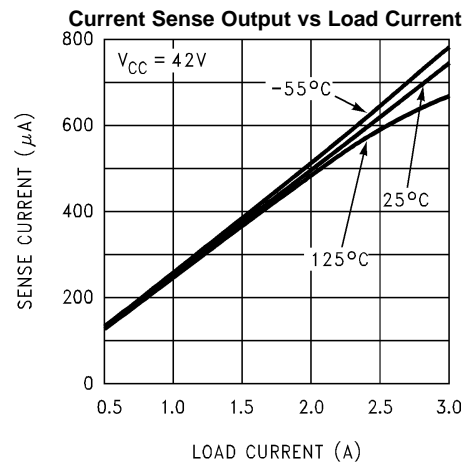

Figure 6.

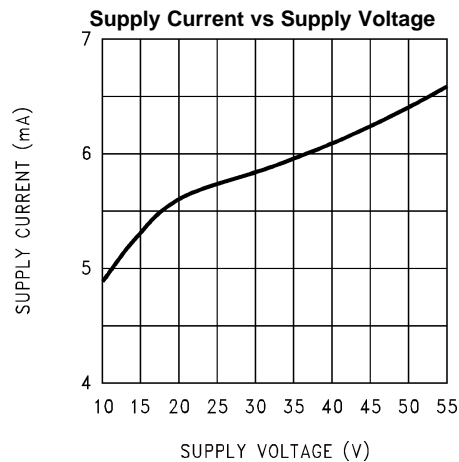

Figure 7.

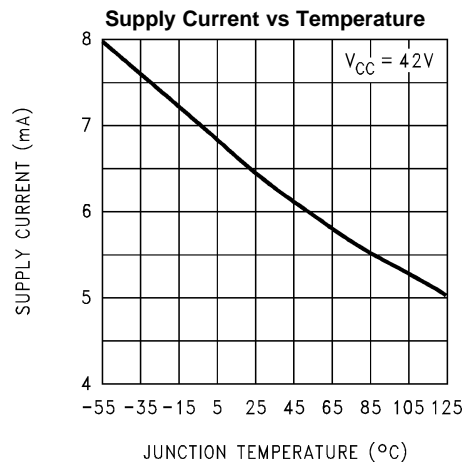
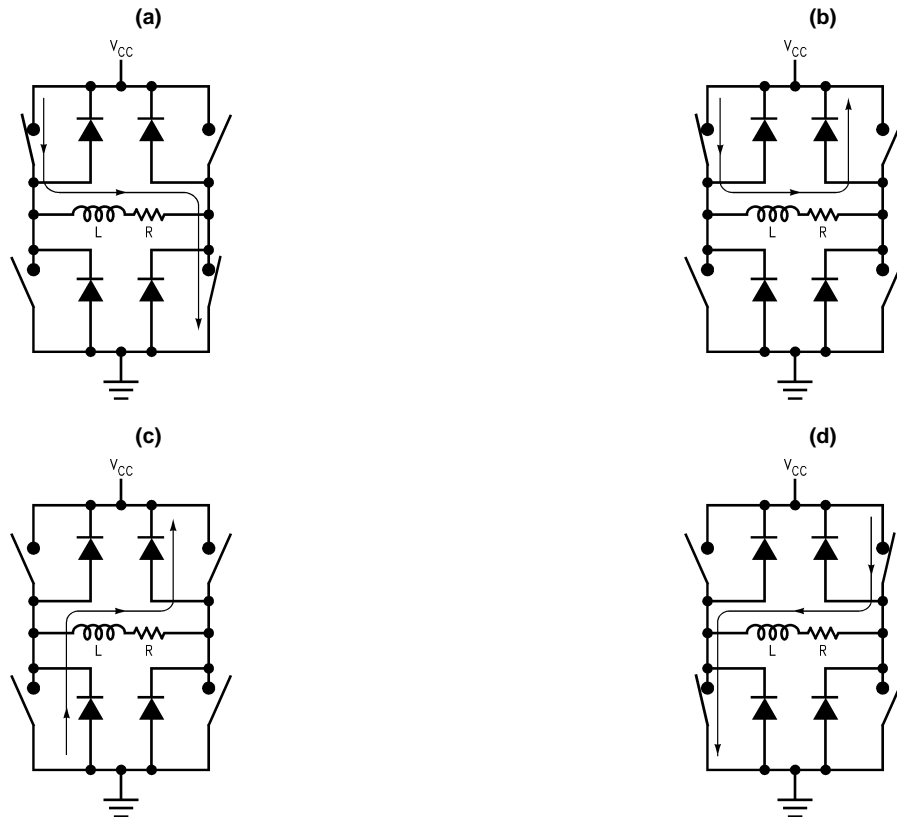

Figure 8.

FUNCTIONAL DESCRIPTIONS

TYPICAL OPERATION OF A CHOPPER AMPLIFIER

Chopper amplifiers employ feedback driven switching of a power bridge to control and limit current in the winding of a motor (Figure 9). The bridge consists of four solid state power switches and four diodes connected in an H configuration. Control circuitry (not shown) monitors the winding current and compares it to a threshold. While the winding current remains less than the threshold, a source switch and a sink switch in opposite halves of the bridge force the supply voltage across the winding, and the winding current increases rapidly towards V_{CC}/R (Figure 9a and Figure 9d). As the winding current surpasses the threshold, the control circuitry turns OFF the sink switch for a fixed period or *off-time*. During the off-time, the source switch and the opposite upper diode short the winding, and the winding current recirculates and decays slowly towards zero (Figure 9b and Figure 9e). At the end of the off-time, the control circuitry turns back ON the sink switch, and the winding current again increases rapidly towards V_{CC}/R (Figure 9a and Figure 9d again). The above sequence repeats to provide a current chopping action that limits the winding current to the threshold (Figure 9g). Chopping only occurs if the winding current reaches the threshold. During a change in the direction of the winding current, the diodes provide a decay path for the initial winding current (Figure 9c and Figure 9f). Since the bridge shorts the winding for a fixed period, this type of chopper amplifier is commonly referred to as a *fixed off-time chopper*.



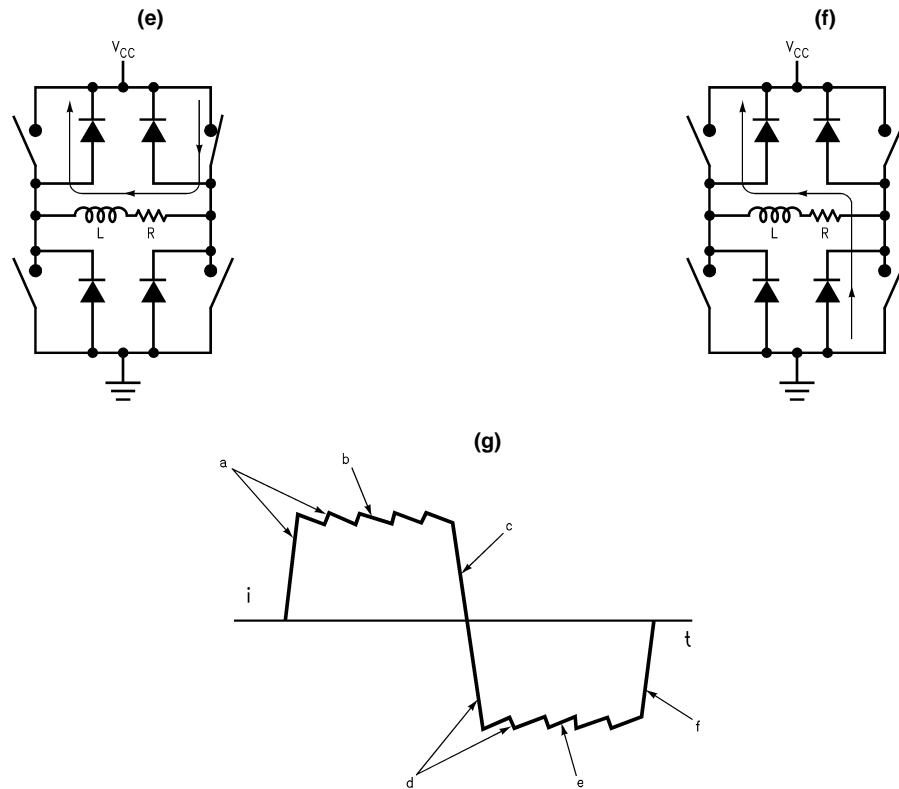

Figure 9. Chopper Amplifier Chopping States: Full V_{CC} Applied Across the Winding (a) and (d), Shorted Winding (b) and (e), Winding Current Decays During a Change in the Direction of the Winding Current (c) and (f), and the Chopped Winding Current (g)

THE LMD18245 CHOPPER AMPLIFIER

The LMD18245 incorporates all the circuit blocks needed to implement a fixed off-time chopper amplifier. These blocks include: an all DMOS, full H-bridge with clamp diodes, an amplifier for sensing the load current, a comparator, a monostable, and a DAC for digital control of the chopping threshold. Also incorporated are logic, level shifting and drive blocks for digital control of the direction of the load current and braking.

THE H-BRIDGE

The power stage consists of four DMOS power switches and associated body diodes connected in an H-bridge configuration (Figure 10).

The time constant to charge or discharge any inductor, in this case the motor windings, is defined as:

$$\tau = L/R$$

where

- L is the winding inductance
 - R is the sum of the series resistance in the current path including the winding resistance
- (1)

Turning ON a source switch and a sink switch in opposite halves of the bridge forces the full supply voltage less the switch drops ($I \times R_{DS(ON)}$) across the motor winding. While the bridge remains in this state, the winding current increases exponentially towards a limit dictated by the supply voltage, the switch drops ($I \times R_{DS(ON)}$), and the winding resistance. However, the winding current exponential rate of increase will end when the current chopping circuitry becomes active.

Subsequently turning OFF the sink switch causes a voltage transient that forward biases the body diode of the other source switch. The diode clamps the transient at one diode drop above the supply voltage and provides an alternative current path. While the bridge remains in this state, it essentially shorts the winding, the winding current recirculates and decays exponentially towards zero at a rate that is defined by the L/R time constant.

During a change in the direction of the winding current, both the switches and the body diodes provide a decay path for the initial winding current (Figure 11).

During actual motor operation there are many variables that can effect the motor winding magnetic behavior and performance. Resonance, eddy currents, friction, motor loading, damping, temperature coefficients of the windings, are only a few. These are all issues that are beyond the scope of the this data sheet.

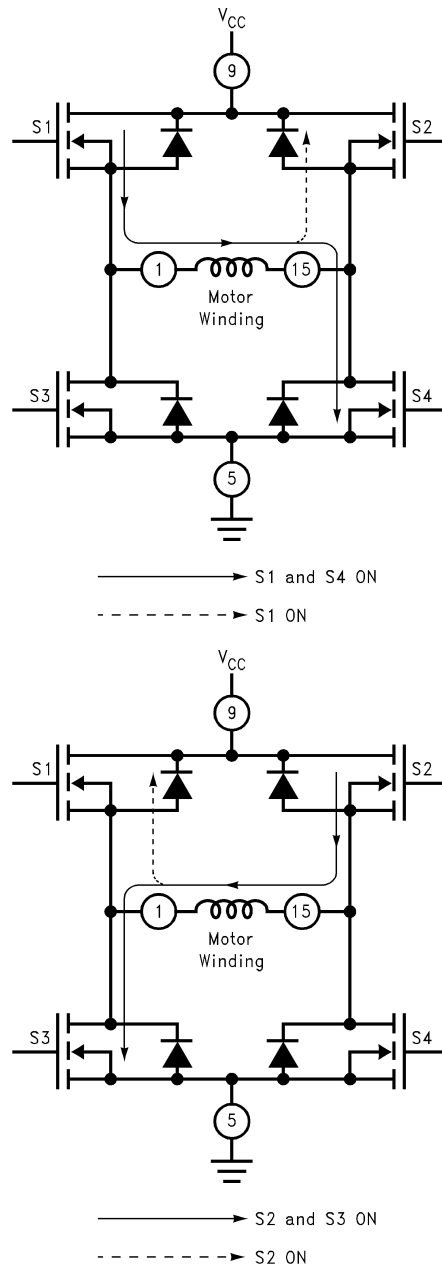

Figure 10. The DMOS H-Bridge

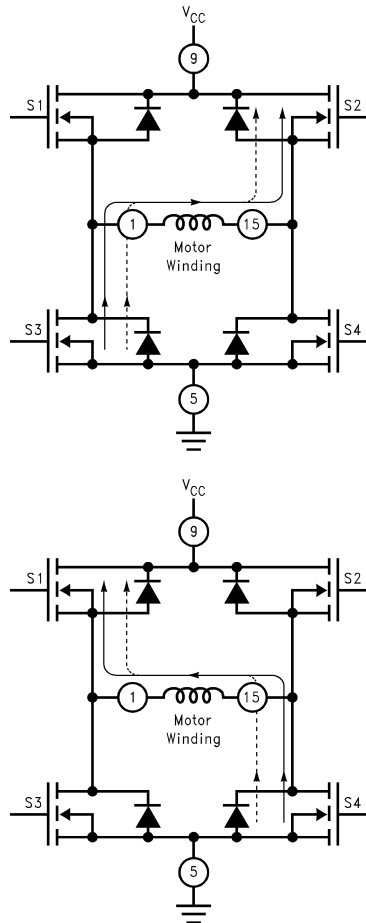

Figure 11. Decay Paths for Initial Winding Current During a Change in the Direction of the Winding Current

THE CURRENT SENSE AMPLIFIER

Many transistor cells in parallel make up the DMOS power switches. The current sense amplifier (Figure 12) uses a small fraction of the cells of both upper switches to provide a unique, low-loss means for sensing the load current. In practice, each upper switch functions as a 1x sense device in parallel with a 4000x power device. The current sense amplifier forces the voltage at the source of the sense device to equal that at the source of the power device; thus, the devices share the total drain current in proportion to the 1:4000 cell ratio. Only the current flowing from drain to source, the forward current, registers at the output of the current sense amplifier. The current sense amplifier, therefore, sources 250 μA per ampere of total forward current conducted by the upper two switches of the power bridge.

The sense current develops a potential across R_S that is proportional to the load current; for example, per ampere of load current, the sense current develops one volt across a 4 k Ω resistor (the product of 250 μA per ampere and 4 k Ω). Since chopping of the load current occurs as the voltage at CS OUT surpasses the threshold (the DAC output voltage), R_S sets the gain of the chopper amplifier; for example, a 2 k Ω resistor sets the gain at two amperes of load current per volt of the threshold (the reciprocal of the product of 250 μA per ampere and 2 k Ω). A quarter watt resistor suffices. A low value capacitor connected in parallel with R_S filters the effects of switching noise from the current sense signal.

While the specified maximum DC voltage compliance at CS OUT is 12V, the specified operating voltage range at CS OUT is 0V to 5V.

THE DIGITAL-TO-ANALOG CONVERTER (DAC)

The DAC sets the threshold voltage for chopping at $V_{\text{DAC REF}} \times D/16$, where D is the decimal equivalent (0–15) of the binary number applied at M4 through M1, the digital inputs of the DAC. M4 is the MSB or most significant bit. For applications that require higher resolution, an external DAC can drive the DAC REF input. While the specified maximum DC voltage compliance at DAC REF is 12V, the specified operating voltage range at DAC REF is 0V to 5V.

THE COMPARATOR, MONOSTABLE AND WINDING CURRENT THRESHOLD FOR CHOPPING

As the voltage at CS OUT surpasses that at the output of the DAC, the comparator triggers the monostable, and the monostable, once triggered, provides a timing pulse to the control logic. During the timing pulse, the power bridge shorts the motor winding, causing current in the winding to recirculate and decay slowly towards zero (Figure 9b and Figure 9e again). A parallel resistor-capacitor network connected between RC (pin #3) and ground sets the timing pulse or off-time at about 1.1 RC seconds.

Chopping of the winding current occurs as the voltage at CS OUT exceeds that at the output of the DAC; so chopping occurs at a winding current threshold of about

$$(V_{\text{DAC REF}} \times D/16) \div ((250 \times 10^{-6}) \times R_S) \text{ amperes.} \quad (2)$$

The R_S value required to set the winding current threshold at the maximum rated current of the LMD18245, with $D = 15$ and $V_{\text{DAC REF}}$ of 5.00V would be:

$$(5.00\text{V} \times 15/16) \div ((250 \times 10^{-6}) \times 6.25 \text{ k}\Omega) = 3.00\text{A} \quad (3)$$

The resulting typical DAC programmable current limit values, for different values of R_S , would be:

Table 1. D to A winding current thresholds for $V_{\text{REF DAC}} = 5.00\text{V}$

D	$R_S = 18.75 \text{ k}\Omega$	$R_S = 9.375 \text{ k}\Omega$	$R_S = 6.250 \text{ k}\Omega$
0	0.00A	0.00A	0.00A
1	0.07A	0.13A	0.20A
2	0.13A	0.27A	0.40A
3	0.20A	0.40A	0.60A
4	0.27A	0.53A	0.80A
5	0.33A	0.67A	1.00A
6	0.40A	0.80A	1.20A
7	0.47A	0.93A	1.40A
8	0.53A	1.07A	1.60A
9	0.60A	1.20A	1.80A
10	0.67A	1.33A	2.00A
11	0.73A	1.47A	2.20A
12	0.80A	1.60A	2.40A
13	0.87A	1.73A	2.60A
14	0.93A	1.87A	2.80A
15	1.00A	2.00A	3.00A

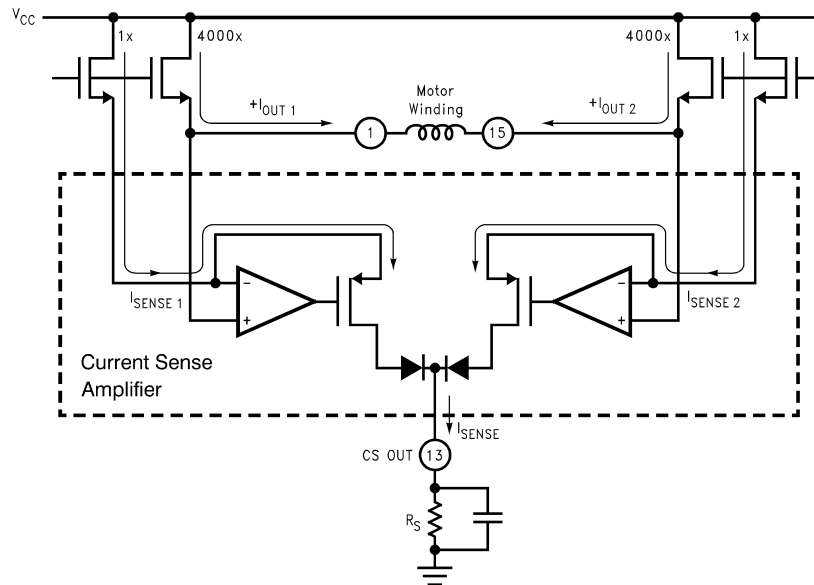

Figure 12. The Source Switches of the Power Bridge and the Current Sense Amplifier

Applications Information

POWER SUPPLY BYPASSING

Step changes in current drawn from the power supply occur repeatedly during normal operation and may cause large voltage spikes across inductance in the power supply line. Care must be taken to limit voltage spikes at V_{CC} to less than the 60V Absolute Maximum Rating. At a change in the direction of the load current, the initial load current tends to raise the voltage at the power supply rail (Figure 11) again. Current transients caused by the reverse recovery of the clamp diodes tend to pull down the voltage at the power supply rail.

Bypassing the power supply line at V_{CC} is required to protect the device and minimize the adverse effects of normal operation on the power supply rail. Using both a 1 μ F high frequency ceramic capacitor and a large-value aluminum electrolytic capacitor is highly recommended. A value of 100 μ F per ampere of load current usually suffices for the aluminum electrolytic capacitor. Both capacitors should have short leads and be located within one half inch of V_{CC} .

OVERCURRENT PROTECTION

If the forward current in either source switch exceeds a 12A threshold, internal circuitry disables both source switches, forcing a rapid decay of the fault current (Figure 13). Approximately 3 μ s after the fault current reaches zero, the device restarts. Automatic restart allows an immediate return to normal operation once the fault condition has been removed. If the fault persists, the device will begin cycling into and out of thermal shutdown. Switching large fault currents may cause potentially destructive voltage spikes across inductance in the power supply line; therefore, the power supply line must be properly bypassed at V_{CC} for the motor driver to survive an extended overcurrent fault.

In the case of a locked rotor, the inductance of the winding tends to limit the rate of change of the fault current to a value easily handled by the protection circuitry. In the case of a low inductance short from either output to ground or between outputs, the fault current could surge past the 12A shutdown threshold, forcing the device to dissipate a substantial amount of power for the brief period required to disable the source switches. Because the fault power must be dissipated by only one source switch, a short from output to ground represents the worst case fault. Any overcurrent fault is potentially destructive, especially while operating with high supply voltages (≥ 30 V), so precautions are in order. Sinking V_{CC} for heat with 1 square inch of 1 ounce copper on the printed circuit board is highly recommended. The sink switches are not internally protected against shorts to V_{CC} .

LMD18245

SNVS110E – APRIL 1998 – REVISED APRIL 2013

www.ti.com

THERMAL SHUTDOWN

Internal circuitry senses the junction temperature near the power bridge and disables the bridge if the junction temperature exceeds about 155°C. When the junction temperature cools past the shutdown threshold (lowered by a slight hysteresis), the device automatically restarts.

UNDERVOLTAGE LOCKOUT

Internal circuitry disables the power bridge if the power supply voltage drops below a rough threshold between 8V and 5V. Should the power supply voltage then exceed the threshold, the device automatically restarts.

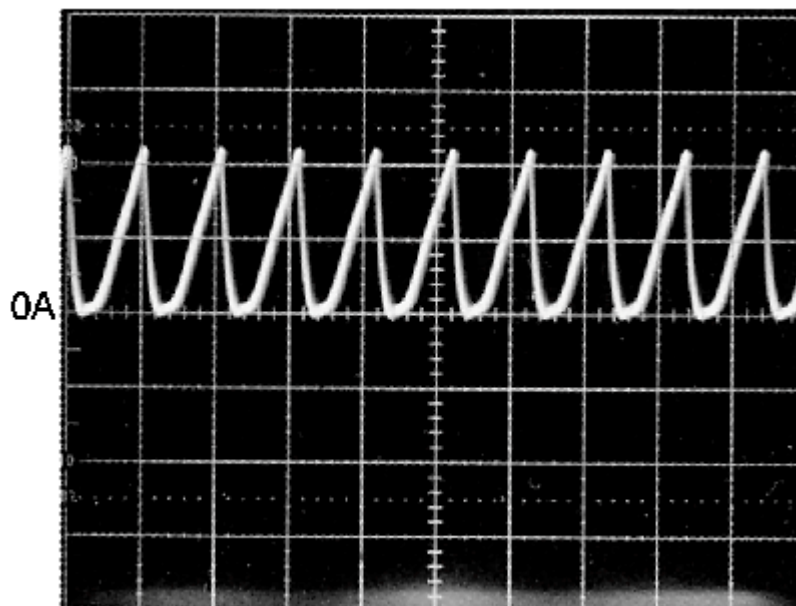

Trace: Fault Current at 5A/div
Horizontal: 20 μs/div

Figure 13. Fault Current with $V_{CC} = 30V$, OUT 1 Shorted to OUT 2, and CS OUT Grounded

The Typical Application

Figure 14 shows the typical application, the power stage of a chopper drive for bipolar stepper motors. The 20 kΩ resistor and 2.2 nF capacitor connected between RC and ground set the off-time at about 48 μs, and the 20 kΩ resistor connected between CS OUT and ground sets the gain at about 200 mA per volt of the threshold for chopping. Digital signals control the thresholds for chopping, the directions of the winding currents, and, by extension, the drive type (full step, half step, etc.). A μprocessor or μcontroller usually provides the digital control signals.

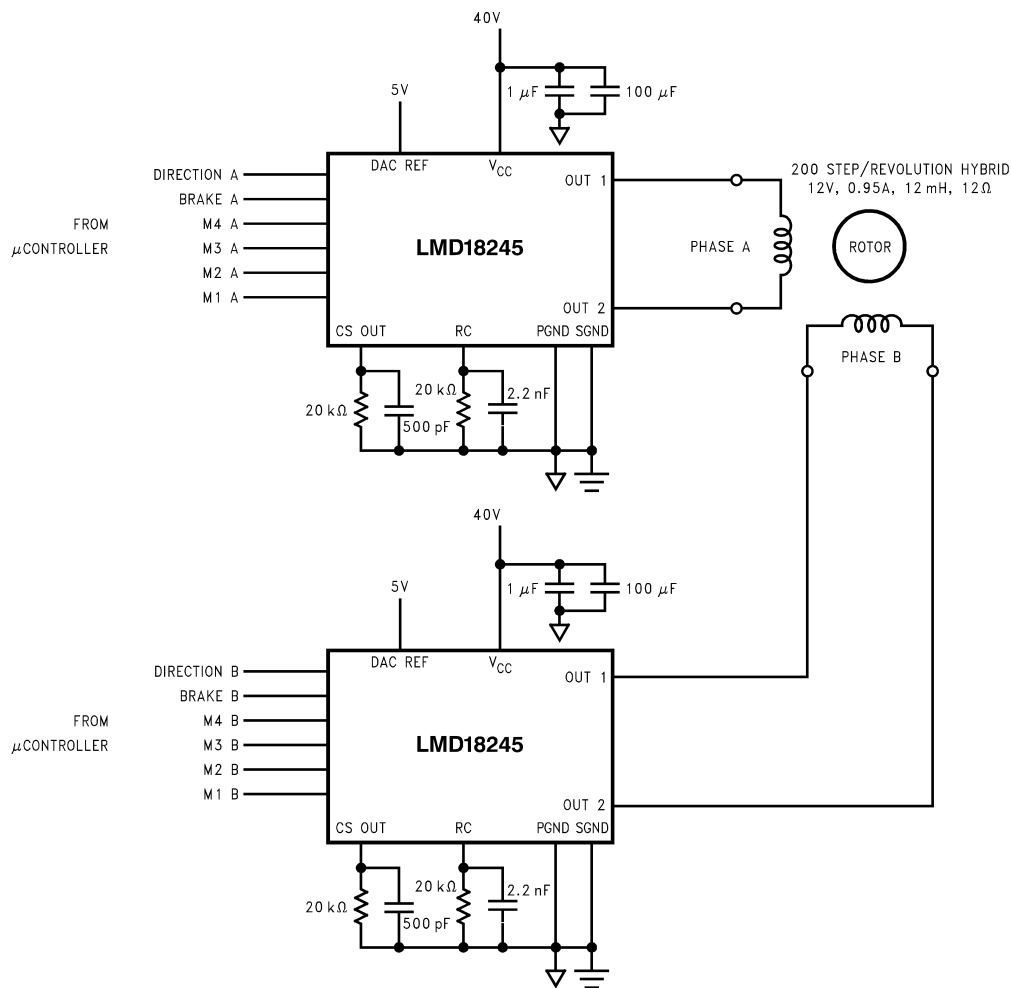

Figure 14. Typical Application Circuit for Driving Bipolar Stepper Motors

ONE-PHASE-ON FULL STEP DRIVE (WAVE DRIVE)

To make the motor take full steps, windings A and B can be energized in the sequence

$$A \rightarrow B \rightarrow A^* \rightarrow B^* \rightarrow A \rightarrow \dots,$$

where A represents winding A energized with current in one direction and A* represents winding A energized with current in the opposite direction. The motor takes one full step each time one winding is de-energized and the other is energized. To make the motor step in the opposite direction, the order of the above sequence must be reversed. [Figure 15](#) shows the winding currents and digital control signals for a wave drive application of the typical application circuit.

TWO-PHASE-ON FULL STEP DRIVE

To make the motor take full steps, windings A and B can also be energized in the sequence

$$AB \rightarrow A^*B \rightarrow A^*B^* \rightarrow AB^* \rightarrow AB \rightarrow \dots,$$

and because both windings are energized at all times, this sequence produces more torque than that produced with wave drive. The motor takes one full step at each change of direction of either winding current. [Figure 16](#) shows the winding currents and digital control signals for this application of the typical application circuit, and [Figure 17](#) shows, for a single phase, the winding current and voltage at the output of the associated current sense amplifier.

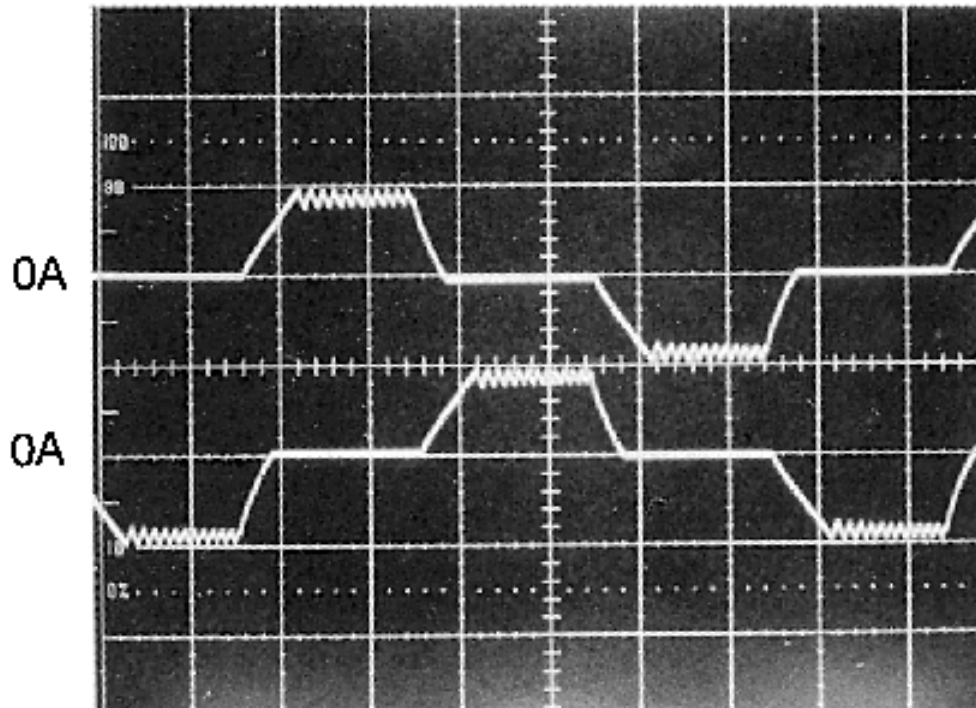

Top Trace: Phase A Winding Current at 1A/div
 Bottom Trace: Phase B Winding Current at 1A/div
 Horizontal: 1 ms/div
 *500 steps/second

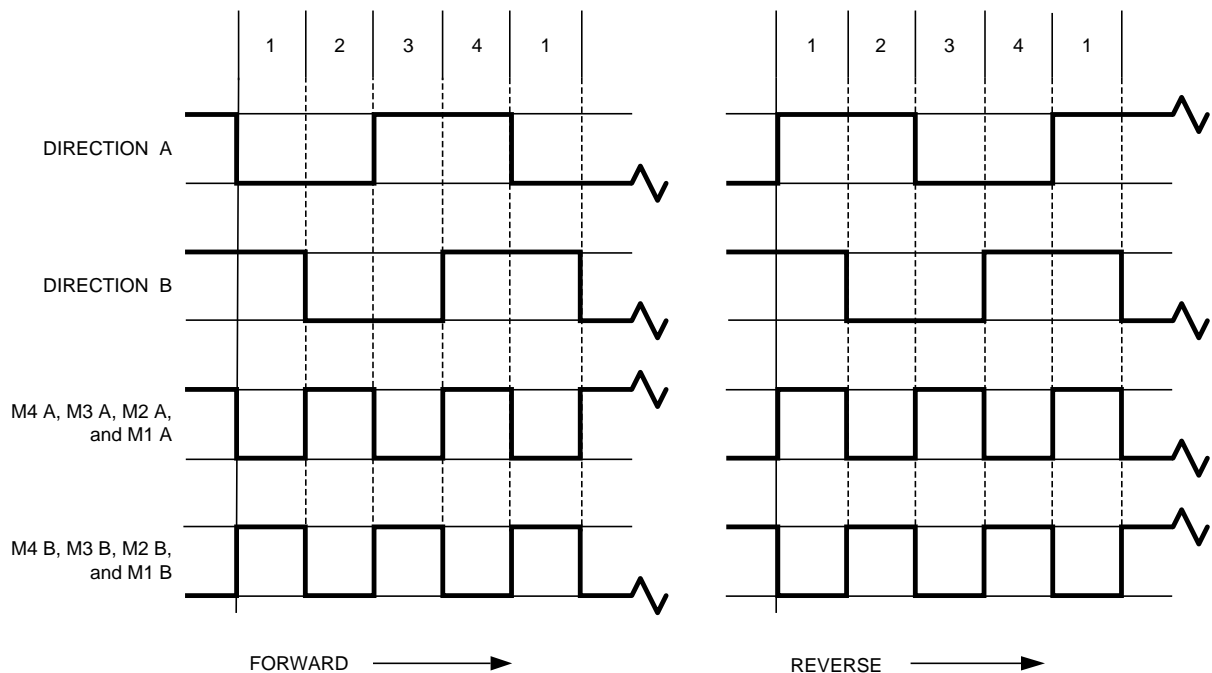

BRAKE A = BRAKE B = 0

Figure 15. Winding Currents and Digital Control Signals for One-Phase-On Drive (Wave Drive)

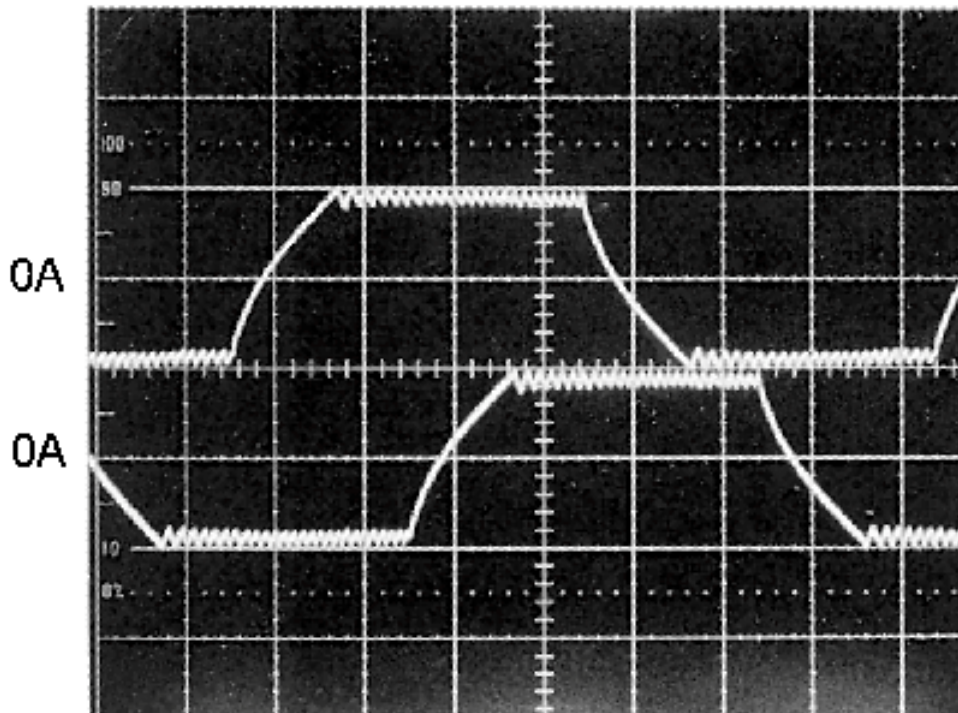

Top Trace: Phase A Winding Current at 1A/div
 Bottom Trace: Phase B Winding Current at 1A/div
 Horizontal: 1 ms/div
 *500 steps/second

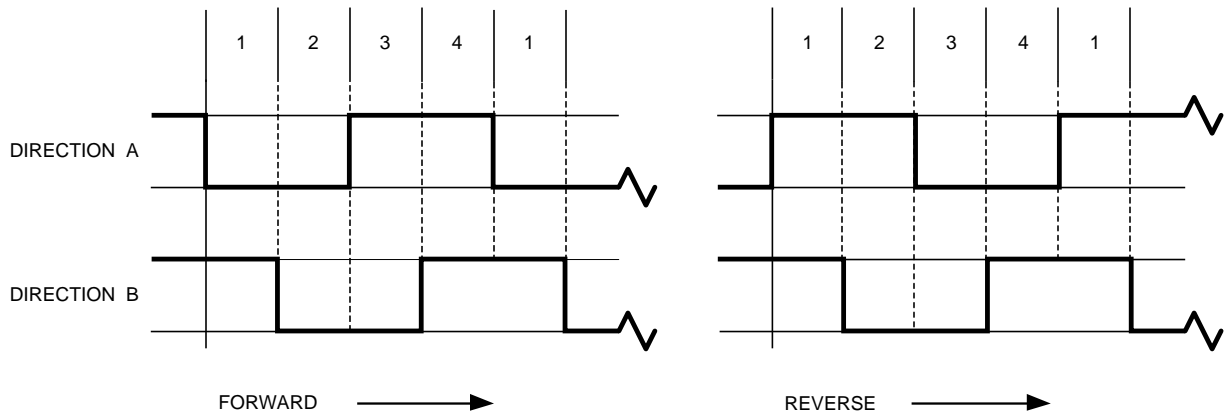

M4 A through M1 A = M4 B through M1 B = 1
 BRAKE A = BRAKE B = 0

Figure 16. Winding Currents and Digital Control Signals for Two-Phase-On Drive

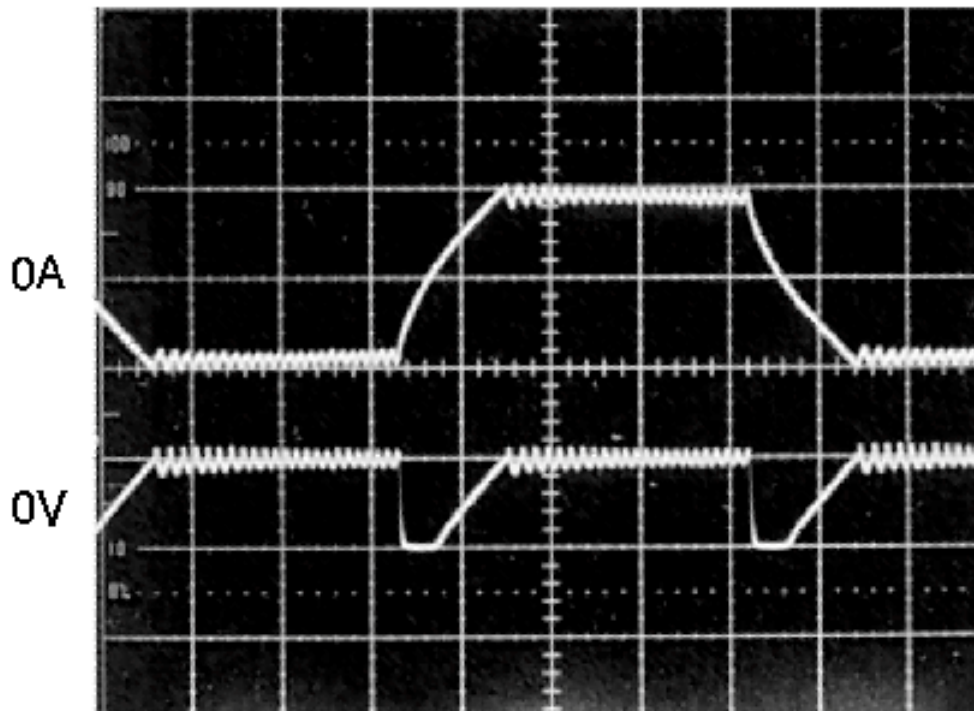

Top Trace: Phase A Winding Current at 1A/div
 Bottom Trace: Phase A Sense Voltage at 5V/div
 Horizontal: 1 ms/div
 *500 steps/second

Figure 17. Winding Current and Voltage at the Output of the Associated Current Sense Amplifier

HALF STEP DRIVE WITHOUT TORQUE COMPENSATION

To make the motor take half steps, windings A and B can be energized in the sequence

A→AB→B→A*B→A*→
 A*B*→B*→AB*→A→ ...

The motor takes one half step each time the number of energized windings changes. It is important to note that although half stepping doubles the step resolution, changing the number of energized windings from two to one decreases (one to two increases) torque by about 40%, resulting in significant torque ripple and possibly noisy operation. [Figure 18](#) shows the winding currents and digital control signals for this half step application of the typical application circuit.

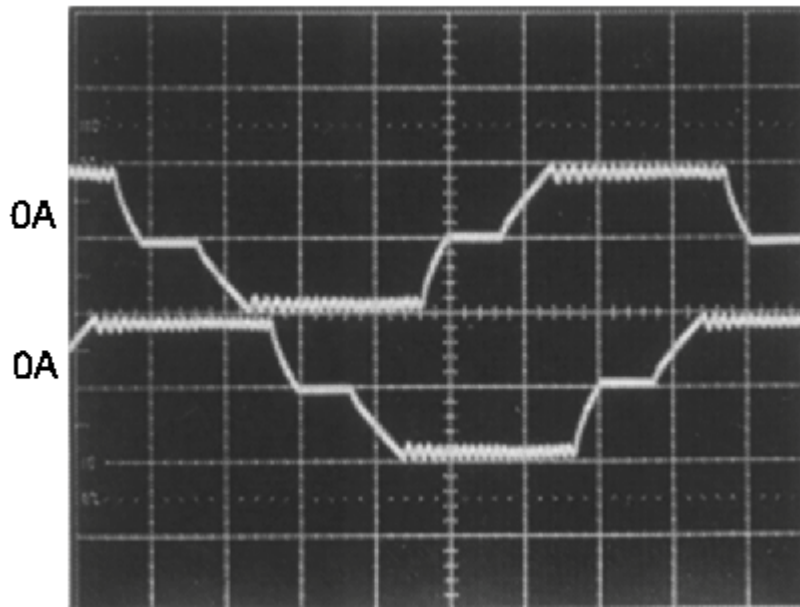

Top Trace: Phase A Winding Current at 1A/div
 Bottom Trace: Phase B Winding Current at 1A/div
 Horizontal: 1 ms/div
 *500 steps/second

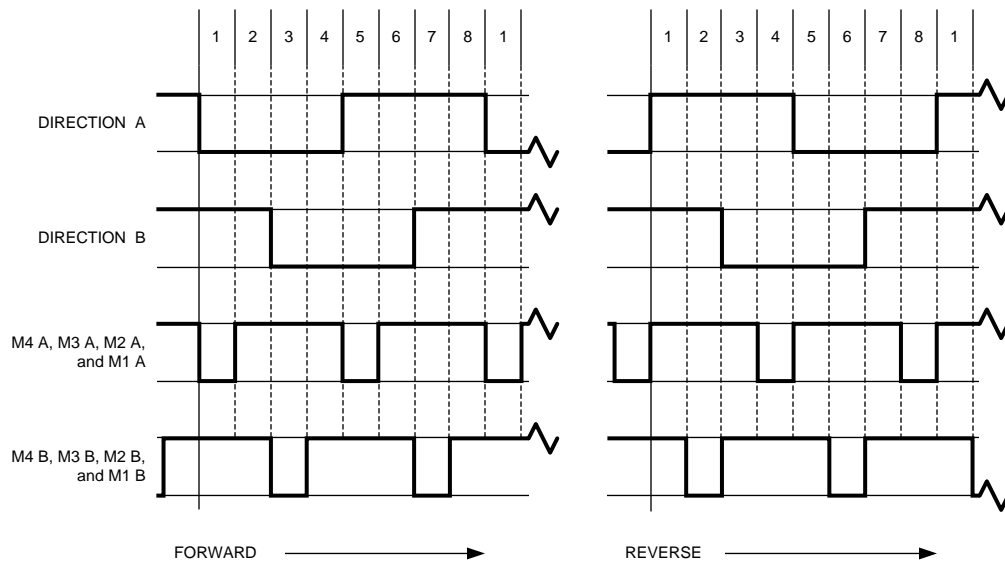

BRAKE A = BRAKE B = 0

Figure 18. Winding Currents and Digital Control Signals for Half Step Drive without Torque Compensation

HALF STEP DRIVE WITH TORQUE COMPENSATION

To make the motor take half steps, the windings can also be energized with sinusoidal currents ([Figure 19](#)). Controlling the winding currents in the fashion shown doubles the step resolution without the significant torque ripple of the prior drive technique. The motor takes one half step each time the level of either winding current changes. Half step drive with torque compensation is microstepping drive. Along with the obvious advantage of increased step resolution, micro-stepping reduces both full step oscillations and resonances that occur as the motor and load combination is driven at its natural resonant frequency or subharmonics thereof. Both of these advantages are obtained by replacing full steps with bursts of microsteps. When compared to full step drive, the motor runs smoother and quieter.

[Table 2](#) shows the lookup table for this application of the typical application circuit. Dividing 90° electrical per full step by two microsteps per full step yields 45° electrical per microstep. α , therefore, increases from 0 to 315° in increments of 45°. Each full 360° cycle comprises eight half steps. Rounding $|\cos\alpha|$ to four bits gives D A, the decimal equivalent of the binary number applied at M4 A through M1 A. DIRECTION A controls the polarity of the current in winding A. [Figure 19](#) shows the sinusoidal winding currents.

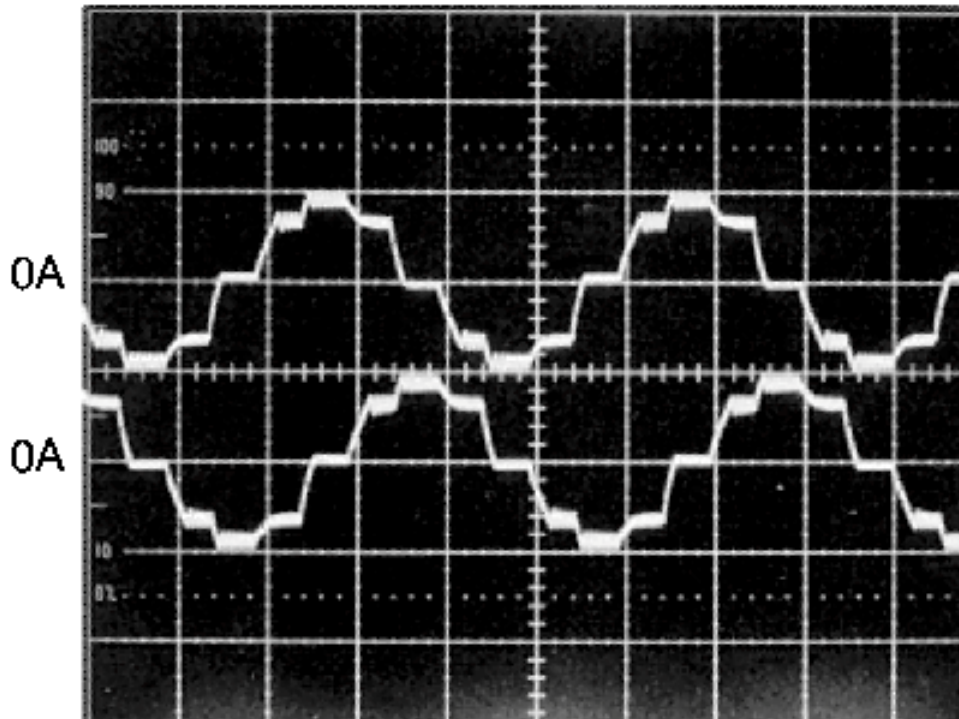

Top Trace: Phase A Winding Current at 1A/div
 Bottom Trace: Phase B Winding Current at 1A/div
 Horizontal: 2 ms/div
 *500 steps/second

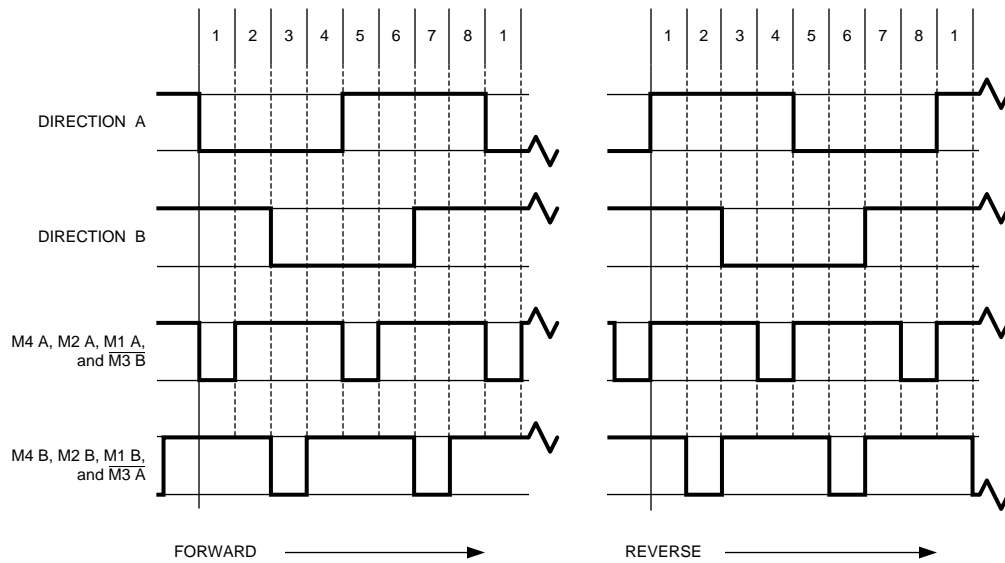

BRAKE A = BRAKE B = 0
 $90^\circ \text{ ELECTRICAL/FULL STEP} \div 2 \text{ MICROSTEPS/FULL STEP} = 45^\circ \text{ ELECTRICAL/MICROSTEP}$

Figure 19. Winding Currents and Digital Control Signals for Half Step Drive with Torque Compensation

Table 2. Lookup Table for Half Step Drive with Torque Compensation

	α	$ \cos(\alpha) $	D A	DIRECTION A	$ \sin(\alpha) $	D B	DIRECTION B
FORWARD ↓	0°	1	15	1	0	0	1
	45°	0.707	11	1	0.707	11	1
	90°	0	0	0	1	15	1
	135°	0.707	11	0	0.707	11	1
	180°	1	15	0	0	0	0
REVERSE ↑	225°	0.707	11	0	0.707	11	0
	270°	0	0	1	1	15	0
	315°	0.707	11	1	0.707	11	0
	REPEAT						

QUARTER STEP DRIVE WITH TORQUE COMPENSATION

Figure 20 shows the winding currents and lookup table for a quarter step drive (four microsteps per full step) with torque compensation.

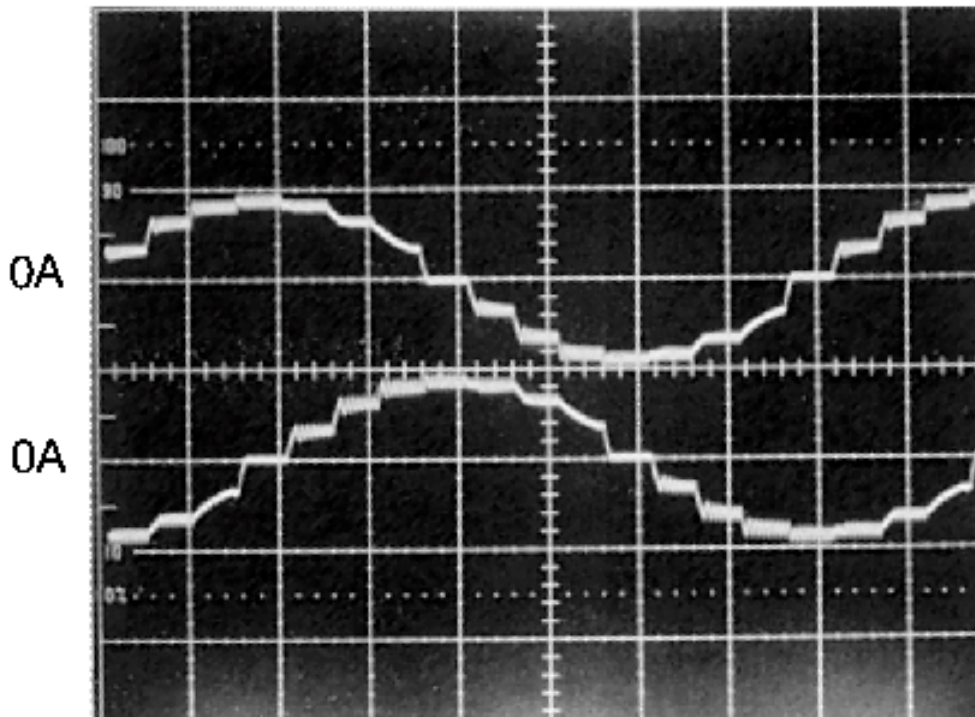

Top Trace: Phase A Winding Current at 1A/div
 Bottom Trace: Phase B Winding Current at 1A/div
 Horizontal: 2ms/div
 *250 steps/second
 $90^\circ \text{ ELECTRICAL/FULL STEP} \div 4 \text{ MICROSTEPS/FULL STEP} = 22.5^\circ \text{ ELECTRICAL/MICROSTEP}$

Figure 20. Winding Currents for Quarter Step Drive with Torque Compensation

Table 3. Lookup Table for Quarter Step Drive with Torque Compensation⁽¹⁾

	α	$ \cos(\alpha) $	D A	DIRECTION A	$ \sin(\alpha) $	D B	DIRECTION B
 FORWARD ↓	0.0°	1	15	1	0	0	1
	22.5°	0.924	14	1	0.383	6	1
	45.0°	0.707	11	1	0.707	11	1
	67.5°	0.383	6	1	0.924	14	1
	90.0°	0	0	0	1	15	1
	112.5°	0.383	6	0	0.924	14	1
	135.0°	0.707	11	0	0.707	11	1
	157.5°	0.924	14	0	0.383	6	1
	180.0°	1	15	0	0	0	0
	202.5°	0.924	14	0	0.383	6	0
	225.0°	0.707	11	0	0.707	11	0
	247.5°	0.383	6	0	0.924	14	0
↑ REVERSE 	270.0°	0	0	1	1	15	0
	292.5°	0.383	6	1	0.924	14	0
	315.0°	0.707	11	1	0.707	11	0
	337.5°	0.924	14	1	0.383	6	0
	REPEAT						

(1) BRAKE A = BRAKE B = 0

Test Circuit and Switching Time Definitions

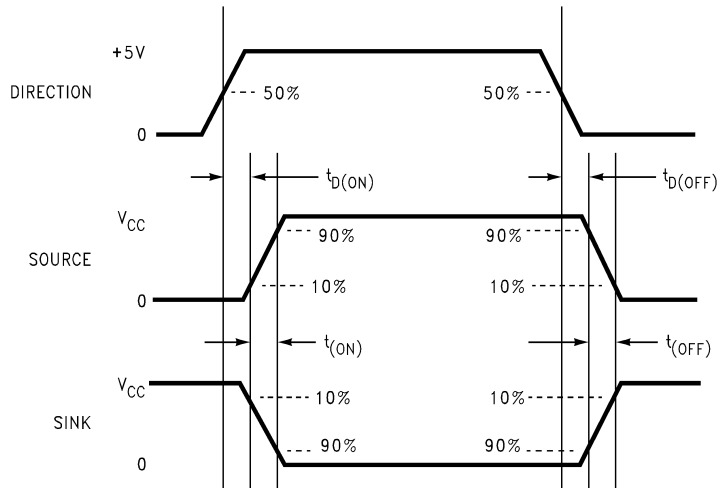
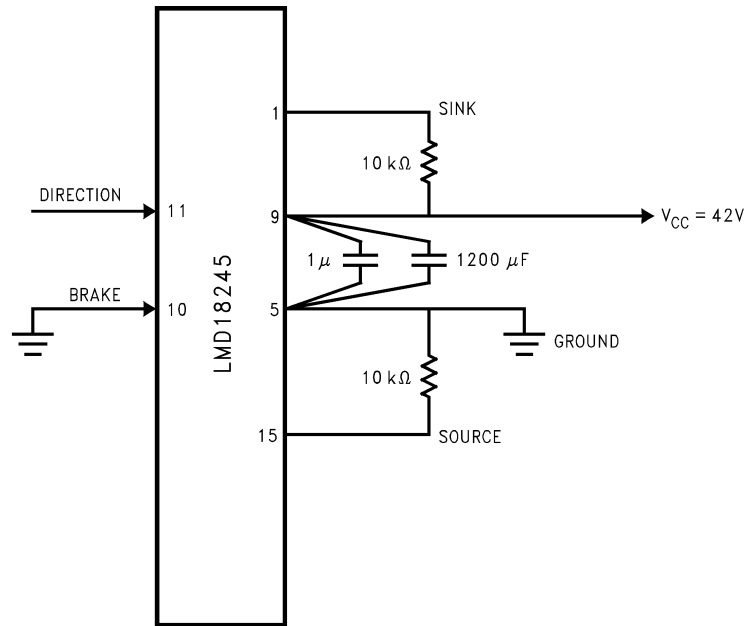

REVISION HISTORY

Changes from Revision D (April 2013) to Revision E	Page
• Changed layout of National Data Sheet to TI format	25

PACKAGING INFORMATION

Orderable part number	Status (1)	Material type (2)	Package Pins	Package qty Carrier	RoHS (3)	Lead finish/ Ball material (4)	MSL rating/ Peak reflow (5)	Op temp (°C)	Part marking (6)
LMD18245T/NOPB	Active	Production	TO-220 (NDL) 15	20 TUBE	Yes	SN	Level-1-NA-UNLIM	-40 to 125	LMD18245T P+
LMD18245T/NOPB.B	Active	Production	TO-220 (NDL) 15	20 TUBE	-	SN	Level-1-NA-UNLIM	-40 to 125	LMD18245T P+

(1) **Status:** For more details on status, see our [product life cycle](#).

(2) **Material type:** When designated, preproduction parts are prototypes/experimental devices, and are not yet approved or released for full production. Testing and final process, including without limitation quality assurance, reliability performance testing, and/or process qualification, may not yet be complete, and this item is subject to further changes or possible discontinuation. If available for ordering, purchases will be subject to an additional waiver at checkout, and are intended for early internal evaluation purposes only. These items are sold without warranties of any kind.

(3) **RoHS values:** Yes, No, RoHS Exempt. See the [TI RoHS Statement](#) for additional information and value definition.

(4) **Lead finish/Ball material:** Parts may have multiple material finish options. Finish options are separated by a vertical ruled line. Lead finish/Ball material values may wrap to two lines if the finish value exceeds the maximum column width.

(5) **MSL rating/Peak reflow:** The moisture sensitivity level ratings and peak solder (reflow) temperatures. In the event that a part has multiple moisture sensitivity ratings, only the lowest level per JEDEC standards is shown. Refer to the shipping label for the actual reflow temperature that will be used to mount the part to the printed circuit board.

(6) **Part marking:** There may be an additional marking, which relates to the logo, the lot trace code information, or the environmental category of the part.

Multiple part markings will be inside parentheses. Only one part marking contained in parentheses and separated by a "-" will appear on a part. If a line is indented then it is a continuation of the previous line and the two combined represent the entire part marking for that device.

Important Information and Disclaimer: The information provided on this page represents TI's knowledge and belief as of the date that it is provided. TI bases its knowledge and belief on information provided by third parties, and makes no representation or warranty as to the accuracy of such information. Efforts are underway to better integrate information from third parties. TI has taken and continues to take reasonable steps to provide representative and accurate information but may not have conducted destructive testing or chemical analysis on incoming materials and chemicals. TI and TI suppliers consider certain information to be proprietary, and thus CAS numbers and other limited information may not be available for release.

In no event shall TI's liability arising out of such information exceed the total purchase price of the TI part(s) at issue in this document sold by TI to Customer on an annual basis.

TUBE

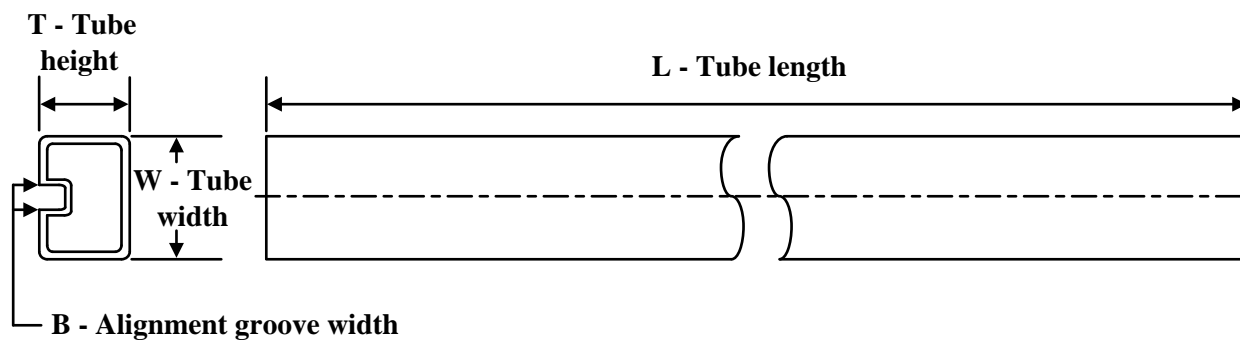

*All dimensions are nominal

Device	Package Name	Package Type	Pins	SPQ	L (mm)	W (mm)	T (μm)	B (mm)
LMD18245T/NOPB	NDL	TO-220	15	20	502	34	12192	0
LMD18245T/NOPB.B	NDL	TO-220	15	20	502	34	12192	0

IMPORTANT NOTICE AND DISCLAIMER

TI PROVIDES TECHNICAL AND RELIABILITY DATA (INCLUDING DATASHEETS), DESIGN RESOURCES (INCLUDING REFERENCE DESIGNS), APPLICATION OR OTHER DESIGN ADVICE, WEB TOOLS, SAFETY INFORMATION, AND OTHER RESOURCES "AS IS" AND WITH ALL FAULTS, AND DISCLAIMS ALL WARRANTIES, EXPRESS AND IMPLIED, INCLUDING WITHOUT LIMITATION ANY IMPLIED WARRANTIES OF MERCHANTABILITY, FITNESS FOR A PARTICULAR PURPOSE OR NON-INFRINGEMENT OF THIRD PARTY INTELLECTUAL PROPERTY RIGHTS.

These resources are intended for skilled developers designing with TI products. You are solely responsible for (1) selecting the appropriate TI products for your application, (2) designing, validating and testing your application, and (3) ensuring your application meets applicable standards, and any other safety, security, regulatory or other requirements.

These resources are subject to change without notice. TI grants you permission to use these resources only for development of an application that uses the TI products described in the resource. Other reproduction and display of these resources is prohibited. No license is granted to any other TI intellectual property right or to any third party intellectual property right. TI disclaims responsibility for, and you fully indemnify TI and its representatives against any claims, damages, costs, losses, and liabilities arising out of your use of these resources.

TI's products are provided subject to [TI's Terms of Sale](#), [TI's General Quality Guidelines](#), or other applicable terms available either on [ti.com](#) or provided in conjunction with such TI products. TI's provision of these resources does not expand or otherwise alter TI's applicable warranties or warranty disclaimers for TI products. Unless TI explicitly designates a product as custom or customer-specified, TI products are standard, catalog, general purpose devices.

TI objects to and rejects any additional or different terms you may propose.

Copyright © 2025, Texas Instruments Incorporated

Last updated 10/2025

OUR CERTIFICATE

DiGi provide top-quality products and perfect service for customer worldwide through standardization, technological innovation and continuous improvement. DiGi through third-party certification, we stricly control the quality of products and services. Welcome your RFQ to

Email: Info@DiGi-Electronics.com



Tel: +00 852-30501935

RFQ Email: Info@DiGi-Electronics.com

DiGi is a global authorized distributor of electronic components.