

LMG1205YFXT Datasheet



<https://www.DiGi-Electronics.com>

DiGi Electronics Part Number	LMG1205YFXT-DG
Manufacturer	Texas Instruments
Manufacturer Product Number	LMG1205YFXT
Description	IC GATE DRVR HALF-BRIDGE 12DSBGA
Detailed Description	Half-Bridge Gate Driver IC TTL 12-DSBGA



Tel: +00 852-30501935

RFQ Email: Info@DiGi-Electronics.com

DiGi is a global authorized distributor of electronic components.

Purchase and inquiry

Manufacturer Product Number:

LMG1205YFXT

Series:

-

DiGi-Electronics Programmable:

Not Verified

Channel Type:

Independent

Gate Type:

N-Channel MOSFET

Logic Voltage - VIL, VIH:

1.76V, 1.89V

Input Type:

TTL

Rise / Fall Time (Typ):

7ns, 3.5ns

Mounting Type:

Surface Mount

Supplier Device Package:

12-DSBGA

Manufacturer:

Texas Instruments

Product Status:

Active

Driven Configuration:

Half-Bridge

Number of Drivers:

2

Voltage - Supply:

4.5V ~ 5.5V

Current - Peak Output (Source, Sink):

1.2A, 5A

High Side Voltage - Max (Bootstrap):

100 V

Operating Temperature:

-40°C ~ 125°C (TJ)

Package / Case:

12-WFBGA, DSBGA

Base Product Number:

LMG1205

Environmental & Export classification

RoHS Status:

ROHS3 Compliant

REACH Status:

REACH Unaffected

HTSUS:

8542.39.0001

Moisture Sensitivity Level (MSL):

1 (Unlimited)

ECCN:

EAR99

LMG1205 100-V, 1.2-A to 5-A, Half Bridge GaN Driver with Integrated Bootstrap Diode

1 Features

- Independent high-side and low-side TTL logic inputs
- 1.2-A peak source, 5-A sink current
- High-side floating bias voltage rail operates up to 100 VDC
- Internal bootstrap supply voltage clamping
- Split outputs for adjustable turnon, turnoff strength
- 0.6-Ω pulldown, 2.1-Ω pullup resistance
- Fast propagation times (35 ns typical)
- Excellent propagation delay matching (1.5 ns typical)
- Supply rail undervoltage lockout
- Low power consumption

2 Applications

- Current-fed push-pull converters
- Half and full-bridge converters
- Synchronous buck converters
- Two-switch forward converters
- Forward with active clamp converters

3 Description

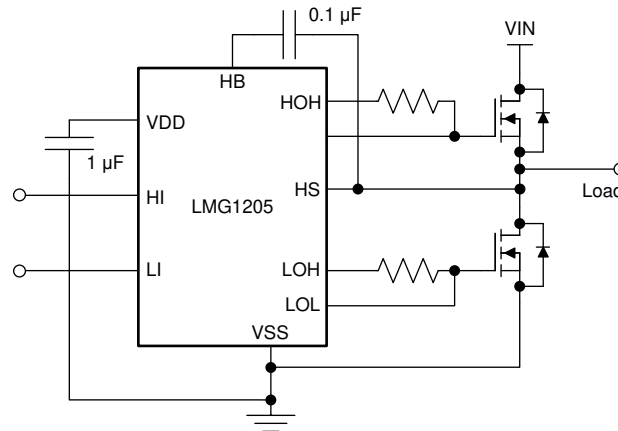
The LMG1205 is designed to drive both the high-side and the low-side enhancement mode Gallium Nitride (GaN) FETs in a synchronous buck, boost, or half-bridge configuration. The device has an integrated 100-V bootstrap diode and independent inputs for the high-side and low-side outputs for maximum control flexibility. The high-side bias voltage is generated using a bootstrap technique and is internally clamped at 5 V, which prevents the gate voltage from exceeding the maximum gate-source voltage rating of enhancement mode GaN FETs. The inputs of the LMG1205 are TTL logic compatible and can withstand input voltages up to 14 V regardless of the VDD voltage. The LMG1205 has split-gate outputs, providing flexibility to adjust the turnon and turnoff strength independently.

In addition, the strong sink capability of the LMG1205 maintains the gate in the low state, preventing unintended turnon during switching. The LMG1205 can operate up to several MHz. The LMG1205 is available in a 12-pin DSBGA package that offers a compact footprint and minimized package inductance.

Device Information⁽¹⁾

PART NUMBER	PACKAGE	BODY SIZE (NOM)
LMG1205	DSBGA (12)	2.00 mm × 2.00 mm

(1) For all available packages, see the orderable addendum at the end of the data sheet.



Copyright © 2017, Texas Instruments Incorporated

Simplified Application Diagram

LMG1205

SNOSD37B – MARCH 2017 – REVISED APRIL 2023

Table of Contents

1 Features	1	7.4 Device Functional Modes	12
2 Applications	1	8 Application and Implementation	13
3 Description	1	8.1 Application Information.....	13
4 Revision History	2	8.2 Typical Application.....	13
5 Pin Configuration and Functions	3	9 Power Supply Recommendations	17
6 Specifications	4	10 Layout	18
6.1 Absolute Maximum Ratings.....	4	10.1 Layout Guidelines.....	18
6.2 ESD Ratings.....	4	10.2 Layout Examples.....	18
6.3 Recommended Operating Conditions.....	4	11 Device and Documentation Support	19
6.4 Thermal Information.....	4	11.1 Device Support.....	19
6.5 Electrical Characteristics.....	6	11.2 Documentation Support.....	19
6.6 Switching Characteristics.....	7	11.3 Receiving Notification of Documentation Updates..	19
6.7 Typical Characteristics.....	8	11.4 Support Resources.....	19
7 Detailed Description	11	11.5 Trademarks.....	19
7.1 Overview.....	11	11.6 Electrostatic Discharge Caution.....	19
7.2 Functional Block Diagram.....	11	11.7 Glossary.....	19
7.3 Feature Description.....	11		

4 Revision History

NOTE: Page numbers for previous revisions may differ from page numbers in the current version.

Changes from Revision A (February 2018) to Revision B (April 2023)	Page
• Changed title of data sheet from 80-V to 100-V.....	1
• Added clamping circuit delay time and functional explanation to Section 7.3.3	12
• Changed equation in Section 8.2.2.2	14

Changes from Revision * (March 2017) to Revision A (February 2018)	Page
• Changed title of data sheet	1

5 Pin Configuration and Functions

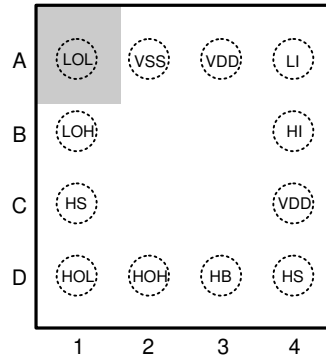


Figure 5-1. YFX Package 12-Pin DSBGA Top View

Table 5-1. Pin Functions

PIN		TYPE (2)	DESCRIPTION
NUMBER	NAME		
A1	LOL	O	Low-side gate driver sink-current output: connect to the gate of the low-side GaN FET with a short, low inductance path. A gate resistor can be used to adjust the turnoff speed.
A2	VSS	G	Ground return: all signals are referenced to this ground.
A3, C4(1)	VDD	P	5-V positive gate drive supply: locally decouple to VSS using low ESR/ESL capacitor located as close as possible to the IC.
A4	LI	I	Low-side driver control input. The LMG1205 inputs have TTL type thresholds. Unused inputs must be tied to ground and not left open.
B1	LOH	O	Low-side gate driver source-current output: connect to the gate of low-side GaN FET with a short, low inductance path. A gate resistor can be used to adjust the turnon speed.
B4	HI	I	High-side driver control input. The LMG1205 inputs have TTL type thresholds. Unused inputs must be tied to ground and not left open.
C1, D4(1)	HS	P	High-side GaN FET source connection: connect to the bootstrap capacitor negative terminal and the source of the high-side GaN FET.
D1	HOL	O	High-side gate driver turnoff output: connect to the gate of high-side GaN FET with a short, low inductance path. A gate resistor can be used to adjust the turnoff speed.
D2	HOH	O	High-side gate driver turnon output: connect to the gate of high-side GaN FET with a short, low inductance path. A gate resistor can be used to adjust the turnon speed.
D3	HB	P	High-side gate driver bootstrap rail: connect the positive terminal of the bootstrap capacitor to HB and the negative terminal to HS. The bootstrap capacitor must be placed as close as possible to the IC.

(1) A3 and C4, C1 and D4 are internally connected

(2) I = Input, O = Output, G = Ground, P = Power

LMG1205

SNOSD37B – MARCH 2017 – REVISED APRIL 2023

6 Specifications

6.1 Absolute Maximum Ratings

over operating free-air temperature range (unless otherwise noted)⁽¹⁾

	MIN	MAX	UNIT
VDD to VSS	-0.3	7	V
HB to HS	-0.3	7	V
LI or HI input	-0.3	15	V
LOH, LOL output	-0.3	VDD + 0.3	V
HOH, HOL output	$V_{HS} - 0.3$	$V_{HB} + 0.3$	V
HS to VSS	-5	93	V
HS to VSS ⁽²⁾	-5	100	V
HB to VSS	0	100	V
HB to VSS ⁽²⁾	0	107	V
Operating junction temperature		150	°C
Storage temperature, T _{stg}	-55	150	°C

- (1) Stresses beyond those listed under *Absolute Maximum Ratings* may cause permanent damage to the device. These are stress ratings only, which do not imply functional operation of the device at these or any other conditions beyond those indicated under *Recommended Operating Conditions*. Exposure to absolute-maximum-rated conditions for extended periods may affect device reliability.
- (2) Device can withstand 1000 pulses up to the value indicated in the table of 100-ms duration and less than 1% duty cycle over its lifetime.

6.2 ESD Ratings

		VALUE	UNIT
V _(ESD) Electrostatic discharge	Human-body model (HBM), per ANSI/ESDA/JEDEC JS-001 ⁽¹⁾	±1000	V
	Charged-device model (CDM), per JEDEC specification JESD22-C101 ⁽²⁾	±500	

- (1) JEDEC document JEP155 states that 500-V HBM allows safe manufacturing with a standard ESD control process.
- (2) JEDEC document JEP157 states that 250-V CDM allows safe manufacturing with a standard ESD control process.

6.3 Recommended Operating Conditions

over operating free-air temperature range (unless otherwise noted)

	MIN	NOM	MAX	UNIT
VDD	4.5		5.5	V
LI or HI input	0		14	V
HS	-5		90	V
HB	$V_{HS} + 4$		$V_{HS} + 5.5$	V
HS slew rate			50	V/ns
Operating junction temperature	-40		125	°C

6.4 Thermal Information

THERMAL METRIC ⁽¹⁾		LMG1205		UNIT
		YFX (DSBGA)		
		12 PINS		
R _{θJA}	Junction-to-ambient thermal resistance	76.8		°C/W
R _{θJC(top)}	Junction-to-case (top) thermal resistance	0.6		°C/W
R _{θJB}	Junction-to-board thermal resistance	12.0		°C/W
ψ _{JT}	Junction-to-top characterization parameter	1.6		°C/W

6.4 Thermal Information (continued)

THERMAL METRIC ⁽¹⁾		LMG1205	UNIT
		YFX (DSBGA)	
		12 PINS	
Ψ_{JB}	Junction-to-board characterization parameter	12.0	°C/W

- (1) For more information about traditional and new thermal metrics, see the [Semiconductor and IC Package Thermal Metrics](#) application report.

LMG1205

SNOSD37B – MARCH 2017 – REVISED APRIL 2023

6.5 Electrical Characteristics

Specifications are $T_J = 25^\circ\text{C}$. Unless otherwise specified: $V_{DD} = V_{HB} = 5\text{ V}$, $V_{SS} = V_{HS} = 0\text{ V}$.
No load on LOL and HOL or HOH and HOL⁽¹⁾.

PARAMETER		TEST CONDITIONS		MIN	TYP	MAX	UNIT
SUPPLY CURRENTS							
I_{DD}	VDD quiescent current	LI = HI = 0 V, $V_{DD} = V_{HB} = 4\text{ V}$	$T_J = 25^\circ\text{C}$	0.09		0.12	mA
			$T_J = -40^\circ\text{C}$ to 125°C				
I_{DDO}	VDD operating current	f = 500 kHz	$T_J = 25^\circ\text{C}$	2		3	mA
			$T_J = -40^\circ\text{C}$ to 125°C				
I_{HB}	Total HB quiescent current	LI = HI = 0 V, $V_{DD} = V_{HB} = 4\text{ V}$	$T_J = 25^\circ\text{C}$	0.10		0.12	mA
			$T_J = -40^\circ\text{C}$ to 125°C				
I_{HBO}	Total HB operating current	f = 500 kHz	$T_J = 25^\circ\text{C}$	1.5		2.5	mA
			$T_J = -40^\circ\text{C}$ to 125°C				
I_{HBS}	HB to VSS quiescent current	HS = HB = 80 V	$T_J = 25^\circ\text{C}$	0.1		8	μA
			$T_J = -40^\circ\text{C}$ to 125°C				
I_{HBSO}	HB to VSS operating current	f = 500 kHz	$T_J = 25^\circ\text{C}$	0.4		1	mA
			$T_J = -40^\circ\text{C}$ to 125°C				
INPUT PINS							
V_{IR}	Input voltage threshold	Rising edge	$T_J = 25^\circ\text{C}$	2.06		2.18	V
			$T_J = -40^\circ\text{C}$ to 125°C	1.89			
V_{IF}	Input voltage threshold	Falling edge	$T_J = 25^\circ\text{C}$	1.66		1.76	V
			$T_J = -40^\circ\text{C}$ to 125°C	1.48			
V_{IHYS}	Input voltage hysteresis			400			mV
R_I	Input pulldown resistance		$T_J = 25^\circ\text{C}$	200		300	k Ω
			$T_J = -40^\circ\text{C}$ to 125°C	100			
UNDERVOLTAGE PROTECTION							
V_{DDR}	VDD rising threshold		$T_J = 25^\circ\text{C}$	3.8		4.5	V
			$T_J = -40^\circ\text{C}$ to 125°C	3.2			
V_{DDH}	VDD threshold hysteresis			0.2			V
V_{HBR}	HB rising threshold		$T_J = 25^\circ\text{C}$	3.2		3.9	V
			$T_J = -40^\circ\text{C}$ to 125°C	2.5			
V_{HBH}	HB threshold hysteresis			0.2			V
BOOTSTRAP DIODE AND CLAMP							
V_{DL}	Low-current forward voltage	$I_{VDD-HB} = 100\ \mu\text{A}$	$T_J = 25^\circ\text{C}$	0.45		0.65	V
			$T_J = -40^\circ\text{C}$ to 125°C				
V_{DH}	High-current forward voltage	$I_{VDD-HB} = 100\ \text{mA}$	$T_J = 25^\circ\text{C}$	0.9		1	V
			$T_J = -40^\circ\text{C}$ to 125°C				
R_D	Dynamic resistance	$I_{VDD-HB} = 100\ \text{mA}$	$T_J = 25^\circ\text{C}$	1.85		3.6	Ω
			$T_J = -40^\circ\text{C}$ to 125°C				
	HB-HS clamp regulation voltage		$T_J = 25^\circ\text{C}$	5		5.25	V
			$T_J = -40^\circ\text{C}$ to 125°C	4.5			

6.5 Electrical Characteristics (continued)

Specifications are $T_J = 25^\circ\text{C}$. Unless otherwise specified: $V_{DD} = V_{HB} = 5\text{ V}$, $V_{SS} = V_{HS} = 0\text{ V}$.
No load on LOL and HOL or HOH and HOL⁽¹⁾.

PARAMETER		TEST CONDITIONS		MIN	TYP	MAX	UNIT
LOW- and HIGH-SIDE GATE DRIVER							
V_{OL}	Low-level output voltage	$I_{HOL} = I_{LOL} = 100\text{ mA}$	$T_J = 25^\circ\text{C}$		0.06		V
			$T_J = -40^\circ\text{C to } 125^\circ\text{C}$			0.1	
V_{OH}	High-level output voltage $V_{OH} = V_{DD} - LOH$ or $V_{OH} = HB - HOH$	$I_{HOH} = I_{LOH} = 100\text{ mA}$	$T_J = 25^\circ\text{C}$		0.21		V
			$T_J = -40^\circ\text{C to } 125^\circ\text{C}$			0.31	
I_{OHL}	Peak source current	HOH, LOH = 0 V			1.2		A
I_{OLL}	Peak sink current	HOL, LOL = 5 V			5		A

6.6 Switching Characteristics

over operating free-air temperature range (unless otherwise noted)

PARAMETER		TEST CONDITIONS		MIN	TYP	MAX	UNIT
t_{LPHL}	LO turnoff propagation delay	LI falling to LOL falling	$T_J = 25^\circ\text{C}$		33.5		ns
			$T_J = -40^\circ\text{C to } 125^\circ\text{C}$			50	
t_{LPLH}	LO turnon propagation delay	LI rising to LOH rising	$T_J = 25^\circ\text{C}$		35		ns
			$T_J = -40^\circ\text{C to } 125^\circ\text{C}$			50	
t_{HPHL}	HO turnoff propagation delay	HI falling to HOL falling	$T_J = 25^\circ\text{C}$		33.5		ns
			$T_J = -40^\circ\text{C to } 125^\circ\text{C}$			50	
t_{HPLH}	HO turnon propagation delay	HI rising to HOH rising	$T_J = 25^\circ\text{C}$		35		ns
			$T_J = -40^\circ\text{C to } 125^\circ\text{C}$			50	
t_{MON}	Delay matching LO on and HO off	$T_J = 25^\circ\text{C}$			1.5		ns
		$T_J = -40^\circ\text{C to } 125^\circ\text{C}$				8	
t_{MOFF}	Delay matching LO off and HO on	$T_J = 25^\circ\text{C}$			1.5		ns
		$T_J = -40^\circ\text{C to } 125^\circ\text{C}$				8	
t_{HRC}	HO rise time (0.5 V – 4.5 V)	$C_L = 1000\text{ pF}$			7		ns
t_{LRC}	LO rise time (0.5 V – 4.5 V)	$C_L = 1000\text{ pF}$			7		ns
t_{HFC}	HO fall time (0.5 V – 4.5 V)	$C_L = 1000\text{ pF}$			3.5		ns
t_{LFC}	LO fall time (0.5 V – 4.5 V)	$C_L = 1000\text{ pF}$			3.5		ns
t_{PW}	Minimum input pulse width that changes the output				10		ns
t_{BS}	Bootstrap diode reverse recovery time	$I_F = 100\text{ mA}$, $I_R = 100\text{ mA}$			40		ns

(1) Parameters that show only a typical value are ensured by design and may not be tested in production.

LMG1205

SNOSD37B – MARCH 2017 – REVISED APRIL 2023

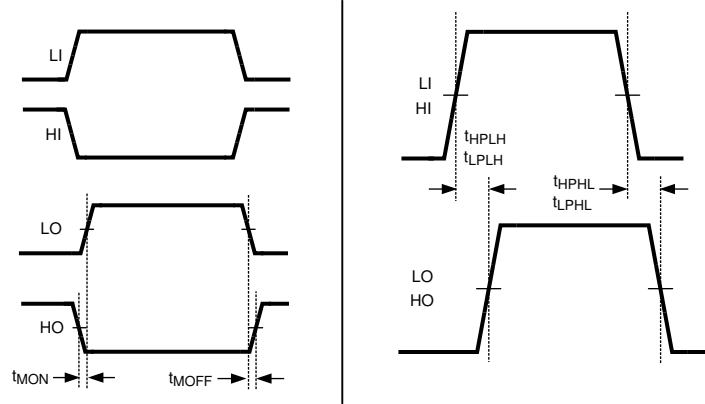


Figure 6-1. Timing Diagram

6.7 Typical Characteristics

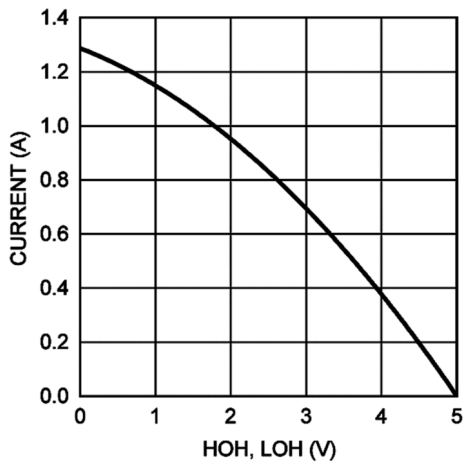


Figure 6-2. Peak Source Current vs Output Voltage

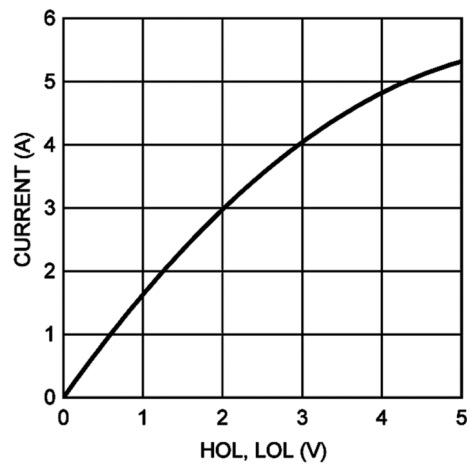


Figure 6-3. Peak Sink Current vs Output Voltage

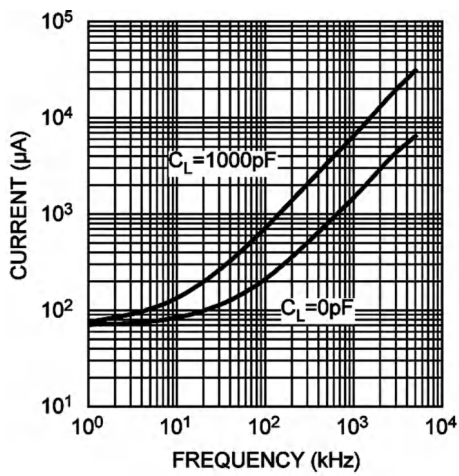


Figure 6-4. I_{DDO} vs Frequency

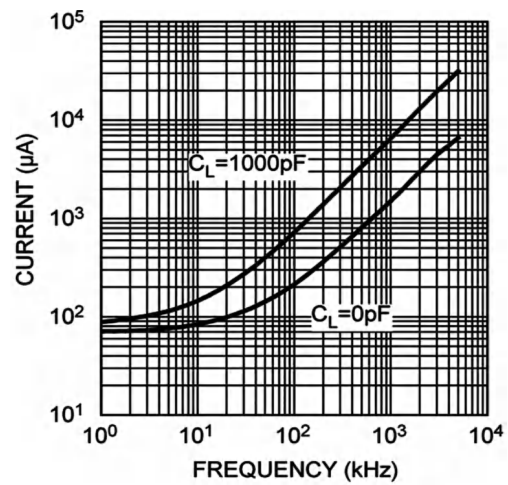


Figure 6-5. I_{HBO} vs Frequency

6.7 Typical Characteristics (continued)

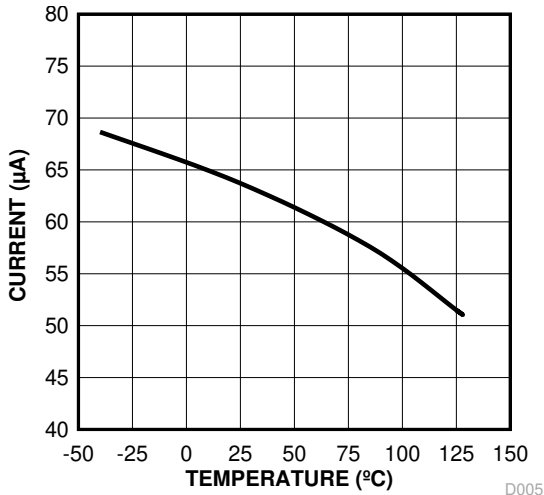


Figure 6-6. I_{DD} vs Temperature

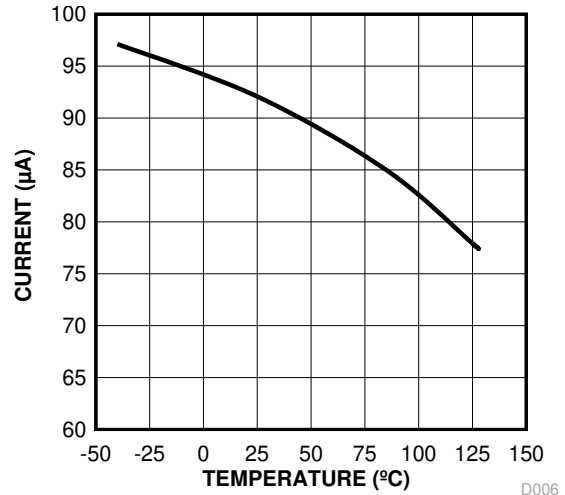


Figure 6-7. I_{HB} vs Temperature

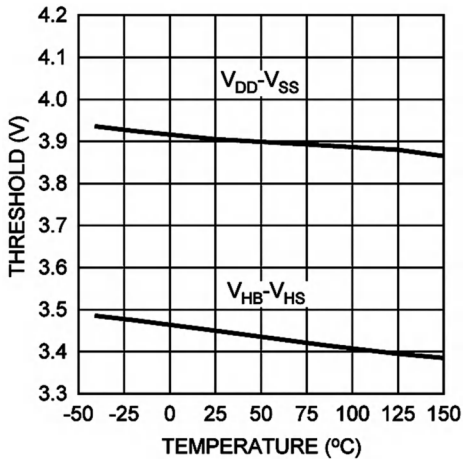


Figure 6-8. UVLO Rising Thresholds vs Temperature

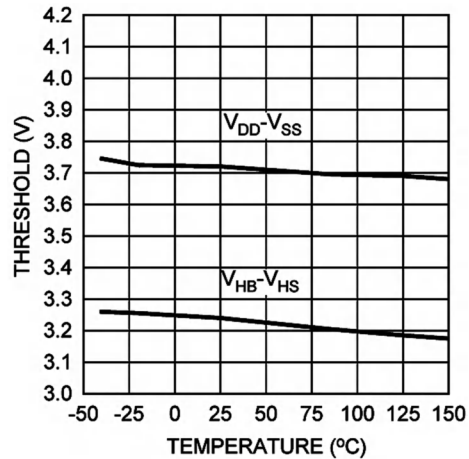


Figure 6-9. UVLO Falling Thresholds vs Temperature

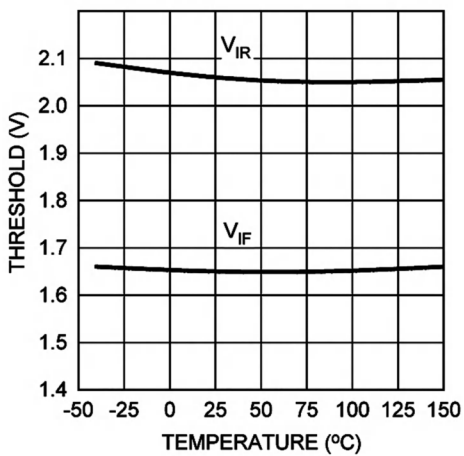


Figure 6-10. Input Thresholds vs Temperature

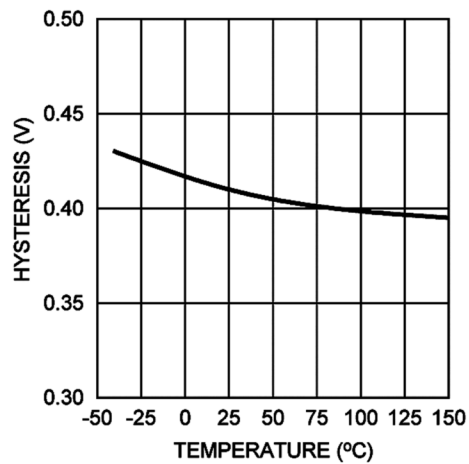


Figure 6-11. Input Threshold Hysteresis vs Temperature

LMG1205

SNOSD37B – MARCH 2017 – REVISED APRIL 2023

6.7 Typical Characteristics (continued)

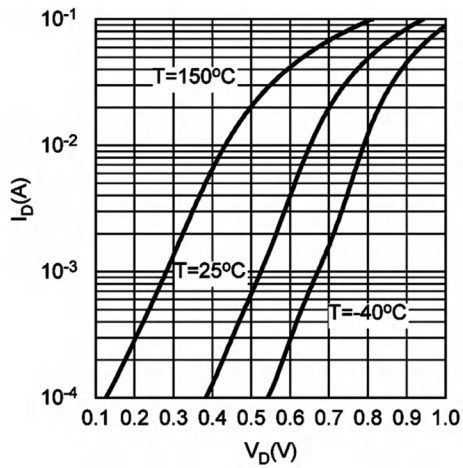


Figure 6-12. Bootstrap Diode Forward Voltage

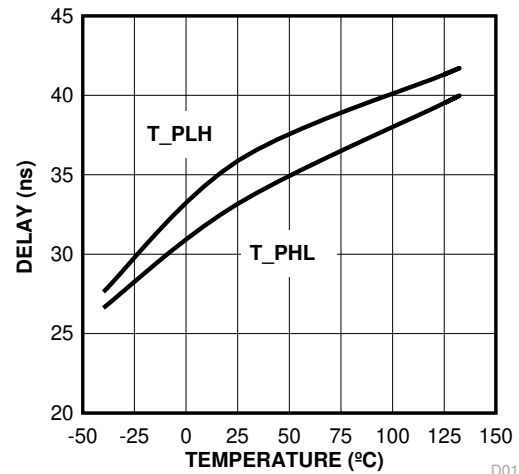


Figure 6-13. Propagation Delay vs Temperature D012

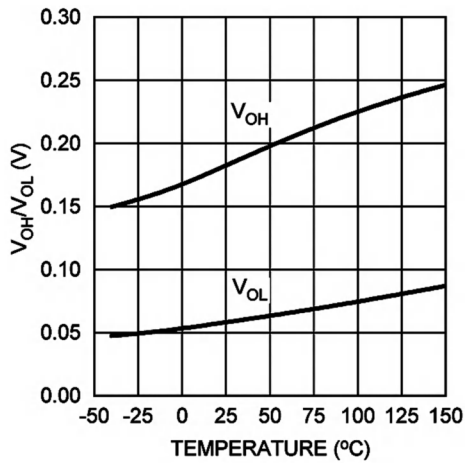


Figure 6-14. LO & HO Gate Drive – High/Low Level Output Voltage vs Temperature

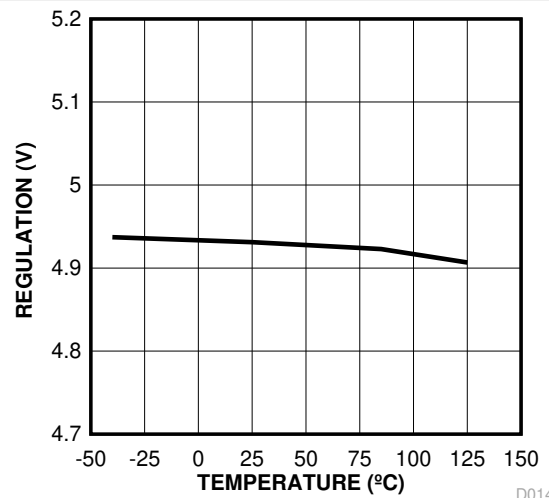


Figure 6-15. HB Regulation Voltage vs Temperature D014

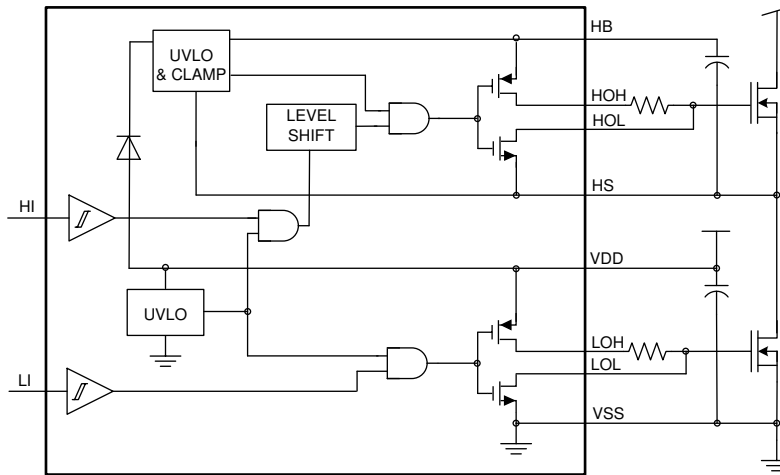
7 Detailed Description

7.1 Overview

The LMG1205 is a high frequency high- and low- side gate driver for enhancement mode Gallium Nitride (GaN) FETs in a synchronous buck, boost, or half-bridge configuration. The high-side bias voltage is generated using a bootstrap technique and is internally clamped at 5 V, which prevents the gate voltage from exceeding the maximum gate-source voltage rating of enhancement mode GaN FETs. The LMG1205 has split-gate outputs with strong sink capability, providing flexibility to adjust the turnon and turnoff strength independently.

The LMG1205 can operate up to several MHz, and is available in a 12-pin DSBGA package that offers a compact footprint and minimized package inductance.

7.2 Functional Block Diagram



Copyright © 2017, Texas Instruments Incorporated

7.3 Feature Description

7.3.1 Input and Output

The input pins of the LMG1205 are independently controlled with TTL input thresholds and can withstand voltages up to 12 V regardless of the VDD voltage. This allows the inputs to be directly connected to the outputs of an analog PWM controller with up to 12-V power supply, eliminating the need for a buffer stage.

The output pulldown and pullup resistance of LMG1205 is optimized for enhancement mode GaN FETs to achieve high frequency and efficient operation. The 0.6-Ω pulldown resistance provides a robust low impedance turnoff path necessary to eliminate undesired turnon induced by high dv/dt or high di/dt. The 2.1-Ω pullup resistance helps reduce the ringing and over-shoot of the switch node voltage. The split outputs of the LMG1205 offers flexibility to adjust the turnon and turnoff speed by independently adding additional impedance in either the turnon path and/or the turnoff path.

If the input signal for either of the the two channels, HI or LI, is not used, the control pin must be tied to either VDD or VSS. These inputs must not be left floating.

7.3.2 Start-up and UVLO

The LMG1205 has an undervoltage lockout (UVLO) on both the VDD and bootstrap supplies. When the VDD voltage is below the threshold voltage of 3.8 V, both the HI and LI inputs are ignored, to prevent the GaN FETs from being partially turned on. Also, if there is insufficient VDD voltage, the UVLO actively pulls the LOL and HOL low. When the VDD voltage is above its UVLO threshold, but the HB to HS bootstrap voltage is below the UVLO threshold of 3.2 V, only HOL is pulled low. Both UVLO threshold voltages have 200 mV of hysteresis to avoid chattering.

LMG1205

SNOSD37B – MARCH 2017 – REVISED APRIL 2023

Table 7-1. VDD UVLO Feature Logic Operation

CONDITION ($V_{HB-HS} > V_{HBR}$ for all cases below)	HI	LI	HO	LO
$V_{DD} - V_{SS} < V_{DDR}$ during device start-up	H	L	L	L
$V_{DD} - V_{SS} < V_{DDR}$ during device start-up	L	H	L	L
$V_{DD} - V_{SS} < V_{DDR}$ during device start-up	H	H	L	L
$V_{DD} - V_{SS} < V_{DDR}$ during device start-up	L	L	L	L
$V_{DD} - V_{SS} < V_{DDR} - V_{DDH}$ after device start-up	H	L	L	L
$V_{DD} - V_{SS} < V_{DDR} - V_{DDH}$ after device start-up	L	H	L	L
$V_{DD} - V_{SS} < V_{DDR} - V_{DDH}$ after device start-up	H	H	L	L
$V_{DD} - V_{SS} < V_{DDR} - V_{DDH}$ after device start-up	L	L	L	L

Table 7-2. V_{HB-HS} UVLO Feature Logic Operation

CONDITION ($V_{DD} > V_{DDR}$ for all cases below)	HI	LI	HO	LO
$V_{HB-HS} < V_{HBR}$ during device start-up	H	L	L	L
$V_{HB-HS} < V_{HBR}$ during device start-up	L	H	L	H
$V_{HB-HS} < V_{HBR}$ during device start-up	H	H	L	H
$V_{HB-HS} < V_{HBR}$ during device start-up	L	L	L	L
$V_{HB-HS} < V_{HBR} - V_{HBH}$ after device start-up	H	L	L	L
$V_{HB-HS} < V_{HBR} - V_{HBH}$ after device start-up	L	H	L	H
$V_{HB-HS} < V_{HBR} - V_{HBH}$ after device start-up	H	H	L	H
$V_{HB-HS} < V_{HBR} - V_{HBH}$ after device start-up	L	L	L	L

7.3.3 HS Negative Voltage and Bootstrap Supply Voltage Clamping

Due to the intrinsic nature of enhancement mode GaN FETs, the source-to-drain voltage of the bottom switch is usually higher than a diode forward voltage drop when the gate is pulled low. This causes negative voltage on HS pin. Moreover, this negative voltage transient may become even more pronounced due to the effects of board layout and device drain/source parasitic inductances. With high-side driver using the floating bootstrap configuration, negative HS voltage can lead to an excessive bootstrap voltage, which can damage the high-side GaN FET. The LMG1205 solves this problem with an internal clamping circuit that prevents the bootstrap voltage from exceeding 5 V typical. The clamping circuit works by opening an internal switch in series with the internal bootstrap diode when the bootstrap voltage exceeds the threshold, preventing further charging. The clamping circuit has a delay of about 270 ns between the threshold being exceeded and charging being stopped. In addition, the clamping circuit is bypassed if an external bootstrap diode is used.

7.3.4 Level Shift

The level-shift circuit is the interface from the high-side input to the high-side driver stage which is referenced to the switch node (HS). The level shift allows control of the HO output, which is referenced to the HS pin and provides excellent delay matching with the low-side driver. Typical delay matching between LO and HO is around 1.5 ns.

7.4 Device Functional Modes

Table 7-3 shows the device truth table.

Table 7-3. Truth Table

HI	LI	HOH	HOL	LOH	LOL
L	L	Open	L	Open	L
L	H	Open	L	H	Open
H	L	H	Open	Open	L
H	H	H	Open	H	Open

8 Application and Implementation

Note

Information in the following applications sections is not part of the TI component specification, and TI does not warrant its accuracy or completeness. TI's customers are responsible for determining suitability of components for their purposes, as well as validating and testing their design implementation to confirm system functionality.

8.1 Application Information

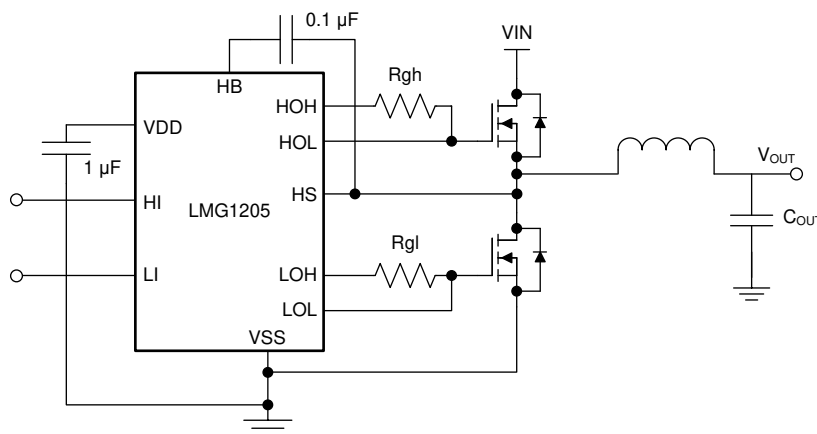
To operate GaN transistors at very high switching frequencies and to reduce associated switching losses, a powerful gate driver is employed between the PWM output of controller and the gates of the GaN transistor. Also, gate drivers are indispensable when the outputs of the PWM controller do not meet the voltage or current levels needed to directly drive the gates of the switching devices. With the advent of digital power, this situation is often encountered because the PWM signal from the digital controller is often a 3.3-V logic signal, which cannot effectively turn on a power switch. A level-shift circuit is needed to boost the 3.3 V signal to the gate-drive voltage (such as 12 V) in order to fully turn on the power device and minimize conduction losses.

Traditional buffer drive circuits based on NPN/PNP bipolar transistors in totem-pole arrangement prove inadequate with digital power because they lack level-shifting capability. Gate drivers effectively combine both the level-shifting and buffer-drive functions. Gate drivers also address other needs such as minimizing the effect of high-frequency switching noise (by placing the high-current driver IC physically close to the power switch), driving gate-drive transformers and controlling floating power-device gates, reducing power dissipation and thermal stress in controllers by moving gate charge power losses from the controller into the driver.

The LMG1205 is a MHz high- and low-side gate driver for enhancement mode GaN FETs in a synchronous buck, boost, or half-bridge configuration. The high-side bias voltage is generated using a bootstrap technique and is internally clamped at 5 V, which prevents the gate voltage from exceeding the maximum gate-source voltage rating of enhancement mode GaN FETs. The LMG1205 has split-gate outputs with strong sink capability, providing flexibility to adjust the turnon and turnoff strength independently.

8.2 Typical Application

The circuit in [Figure 8-1](#) shows a synchronous buck converter to evaluate LMG1205. Detailed synchronous buck converter specifications are listed in [Section 8.2.1](#). Optimization of the power loop (loop impedance from VIN capacitor to PGND) is critical to the performance of the design. Having a high power loop inductance causes significant ringing in the SW node and also causes an associated power loss. For more information, please refer to [Section 11.2.1](#).



Copyright © 2017, Texas Instruments Incorporated

Figure 8-1. Application Circuit

LMG1205

SNOSD37B – MARCH 2017 – REVISED APRIL 2023

8.2.1 Design Requirements

When designing a synchronous buck converter application that incorporates the LMG1205 gate driver and GaN power FETs, some design considerations must be evaluated first to make the most appropriate selection. Among these considerations are the input voltages, passive components, operating frequency, and controller selection. [Table 8-1](#) shows some sample values for a typical application. See [Section 9](#), [Section 10](#), and [Section 8.2.2.3](#) for other key design considerations for the LMG1205.

Table 8-1. Design Parameters

PARAMETER	SAMPLE VALUE
Half-bridge input supply voltage, V_{IN}	48 V
Output voltage, V_{OUT}	12 V
Output current	8 A
Dead time	8 ns
Inductor	4.7 μ H
Switching frequency	1 MHz

8.2.2 Detailed Design Procedure

This procedure outlines the design considerations of LMG1205 in a synchronous buck converter with enhancement mode GaN FET. For additional design help, see [Section 11.2.1](#).

8.2.2.1 VDD Bypass Capacitor

The VDD bypass capacitor provides the gate charge for the low-side and high-side transistors and to absorb the reverse recovery charge of the bootstrap diode. The required bypass capacitance can be calculated with [Equation 1](#).

$$C_{VDD} > \frac{Q_{gH} + Q_{gL} + Q_{rr}}{\Delta V} \quad (1)$$

where

- Q_{gH} and Q_{gL} are gate charge of the high-side and low-side transistors, respectively
- Q_{rr} is the reverse recovery charge of the bootstrap diode, which is typically around 4nC
- ΔV is the maximum allowable voltage drop across the bypass capacitor

TI recommends a 0.1– μ F or larger value, good-quality ceramic capacitor. The bypass capacitor must be placed as close as possible to the device pins to minimize the parasitic inductance.

8.2.2.2 Bootstrap Capacitor

The bootstrap capacitor provides the gate charge for the high-side switch, DC bias power for HB undervoltage lockout circuit, and the reverse recovery charge of the bootstrap diode. The required bypass capacitance can be calculated with [Equation 2](#).

$$C_{BST} > \frac{Q_{gH} + (I_{HB} + I_{GSS}) \times T_{ON} + Q_{rr}}{\Delta V} \quad (2)$$

where

- I_{HB} is the quiescent current of the high-side driver
- T_{on} is the maximum on-time period of the high-side transistor
- I_{GSS} is the gate leakage current of the high-side transistor

A good-quality ceramic capacitor must be used for the bootstrap capacitor. TI recommends placing the bootstrap capacitor as close as possible to the HB and HS pins.

8.2.2.3 Power Dissipation

The power consumption of the driver is an important measure that determines the maximum achievable operating frequency of the driver. It must be kept below the maximum power dissipation limit of the package at the operating temperature. The total power dissipation of the LMG1205 is the sum of the gate driver losses and the bootstrap diode power loss.

The gate driver losses are incurred by charge and discharge of the capacitive load. It can be approximated as

$$P = (C_{\text{LoadH}} + C_{\text{LoadL}}) \times V_{\text{DD}}^2 \times f_{\text{SW}} \quad (3)$$

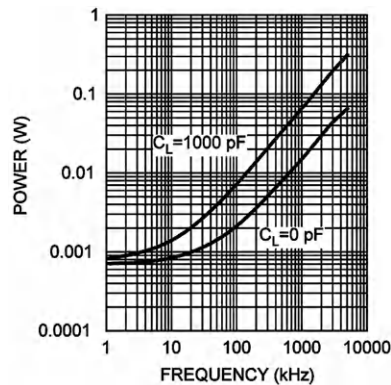
where

- C_{LoadH} and C_{LoadL} are the high-side and the low-side capacitive loads, respectively

It can also be calculated with the total input gate charge of the high-side and the low-side transistors as

$$P = (Q_{\text{gH}} + Q_{\text{gL}}) \times V_{\text{DD}} \times f_{\text{SW}} \quad (4)$$

There are some additional losses in the gate drivers due to the internal CMOS stages used to buffer the LO and HO outputs. Figure 8-2 shows the measured gate driver power dissipation versus frequency and load capacitance. At higher frequencies and load capacitance values, the power dissipation is dominated by the power losses driving the output loads and agrees well with the above equations. Figure 8-2 can be used to approximate the power losses due to the gate drivers.



Gate driver power dissipation (LO+HO), VDD = 5 V

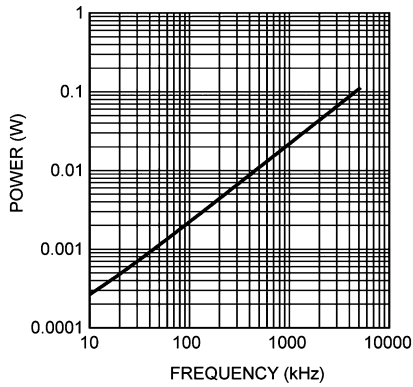
Figure 8-2. Neglecting Bootstrap Diode Losses

The bootstrap diode power loss is the sum of the forward bias power loss that occurs while charging the bootstrap capacitor and the reverse bias power loss that occurs during reverse recovery. Because each of these events happens once per cycle, the diode power loss is proportional to the operating frequency. Larger capacitive loads require more energy to recharge the bootstrap capacitor resulting in more losses. Higher input voltages (V_{IN}) to the half bridge also result in higher reverse recovery losses.

Figure 8-3 and Figure 8-4 show the forward bias power loss and the reverse bias power loss of the bootstrap diode respectively. The plots are generated based on calculations and lab measurements of the diode reverse time and current under several operating conditions. Figure 8-3 and Figure 8-4 can be used to predict the bootstrap diode power loss under different operating conditions.

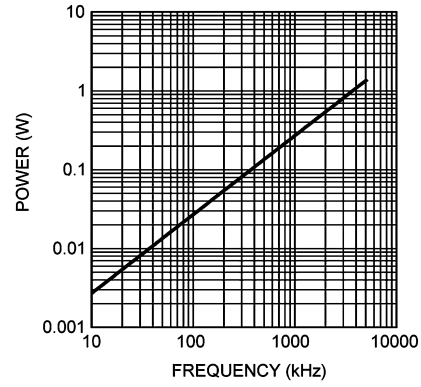
LMG1205

SNOSD37B – MARCH 2017 – REVISED APRIL 2023



The load of high-side driver is a GaN FET with total gate charge of 10 nC.

Figure 8-3. Forward Bias Power Loss of Bootstrap Diode $V_{IN} = 50\text{ V}$



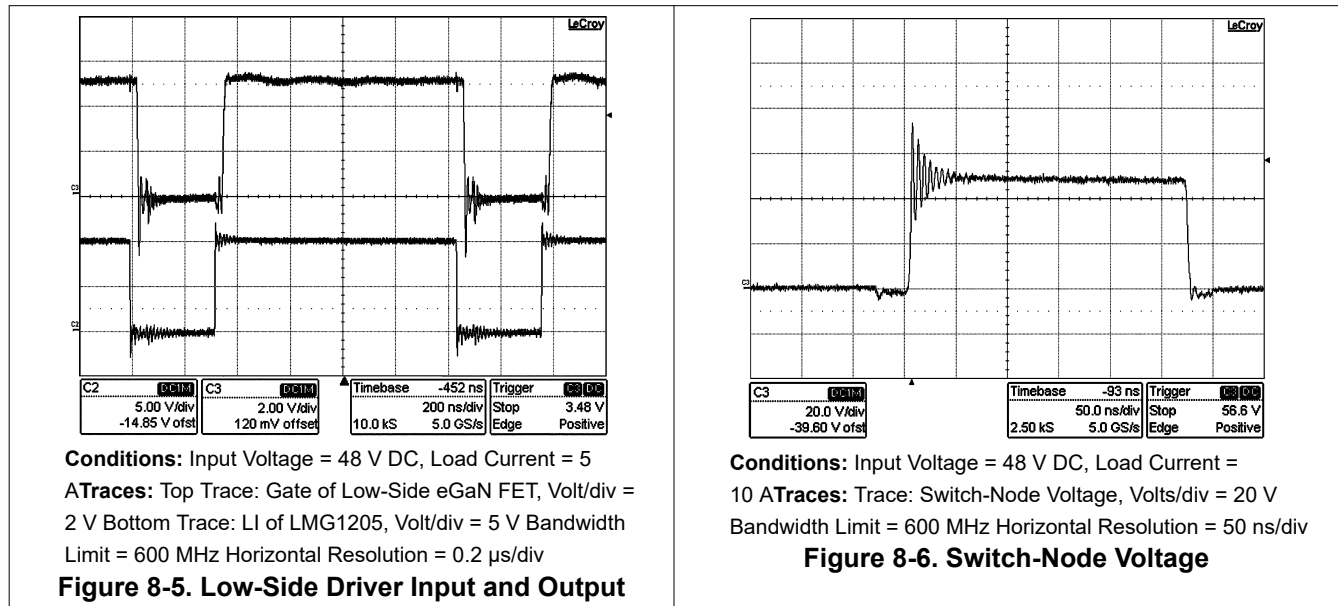
The load of high-side driver is a GaN FET with total gate charge of 10 nC.

Figure 8-4. Reverse Recovery Power Loss of Bootstrap Diode $V_{IN} = 50\text{ V}$

The sum of the driver loss and the bootstrap diode loss is the total power loss of the IC. For a given ambient temperature, the maximum allowable power loss of the IC can be defined as [Equation 5](#).

$$P = \frac{(T_J - T_A)}{\theta_{JA}} \tag{5}$$

8.2.3 Application Curves



9 Power Supply Recommendations

The recommended bias supply voltage range for LMG1205 is from 4.5 V to 5.5 V. The lower end of this range is governed by the internal UVLO protection feature of the VDD supply circuit. TI recommends keeping proper margin to allow for transient voltage spikes while not violating the LMG1205 absolute maximum VDD voltage rating and the GaN transistor gate breakdown voltage limit.

The UVLO protection feature also involves a hysteresis function. This means that once the device is operating in normal mode, if the VDD voltage drops, the device continues to operate in normal mode as far as the voltage drop does not exceed the hysteresis specification, VDDH. If the voltage drop is more than hysteresis specification, the device shuts down. Therefore, while operating at or near the 4.5-V range, the voltage ripple on the VDD power supply output must be smaller than the hysteresis specification of LMG1205 UVLO to avoid triggering device shutdown.

A local bypass capacitor must be placed between the VDD and VSS pins. This capacitor must be located as close as possible to the device. TI recommends a low-ESR, ceramic, surface-mount capacitor. TI also recommends using 2 capacitors across VDD and GND: a 100-nF ceramic surface-mount capacitor for high frequency filtering placed very close to VDD and GND pin, and another surface-mount capacitor, 220 nF to 10 μ F, for IC bias requirements.

LMG1205

SNOSD37B – MARCH 2017 – REVISED APRIL 2023

10 Layout**10.1 Layout Guidelines**

Small gate capacitance and Miller capacitance enable enhancement mode GaN FETs to operate with fast switching speed. The induced high dv/dt and di/dt , coupled with a low gate threshold voltage and limited headroom of enhancement mode GaN FETs gate voltage, make the circuit layout crucial to the optimum performance. Following are some recommendations:

1. The first priority in designing the layout of the driver is to confine the high peak currents that charge and discharge the GaN FETs gate into a minimal physical area. This decreases the loop inductance and minimize noise issues on the gate terminal of the GaN FETs. The GaN FETs must be placed close to the driver.
2. The second high current path includes the bootstrap capacitor, the local ground referenced VDD bypass capacitor and low-side GaN FET. The bootstrap capacitor is recharged on a cycle-by-cycle basis through the bootstrap diode from the ground referenced VDD capacitor. The recharging occurs in a short time interval and involves high peak current. Minimizing this loop length and area on the circuit board is important to ensure reliable operation.
3. The parasitic inductance in series with the source of the high-side FET and the low-side FET can impose excessive negative voltage transients on the driver. TI recommends connecting the HS pin and VSS pin to the respective source of the high-side and low-side transistors with a short and low-inductance path.
4. The parasitic source inductance, along with the gate capacitor and the driver pull-down path, can form an LCR resonant tank, resulting in gate voltage oscillations. An optional resistor or ferrite bead can be used to damp the ringing.
5. Low ESR/ESL capacitors must be connected close to the IC, between VDD and VSS pins and between the HB and HS pins to support the high peak current being drawn from VDD during turnon of the FETs. Keeping bullet #1 (minimized GaN FETs gate driver loop) as the first priority, it is also desirable to place the VDD decoupling capacitor and the HB to HS bootstrap capacitor on the same side of the PC board as the driver. The inductance of vias can impose excessive ringing on the IC pins.
6. To prevent excessive ringing on the input power bus, good decoupling practices are required by placing low-ESR ceramic capacitors adjacent to the GaN FETs.

Figure 10-1 and Figure 10-2 show recommended layout patterns for the LMG1205. Two cases are considered: (1) without any gate resistors, and (2) with an optional turnon gate resistor. Note that 0402 surface mount package is assumed for the passive components in the drawings. For information on DSBGA package assembly, refer to Section 11.2.1.

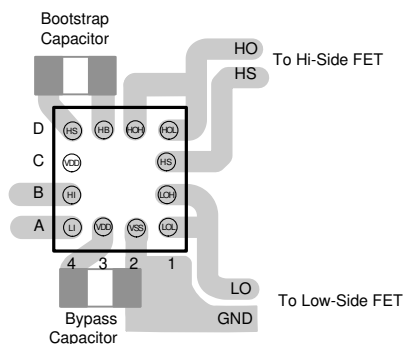
10.2 Layout Examples

Figure 10-1. Layout Example Without Gate Resistors

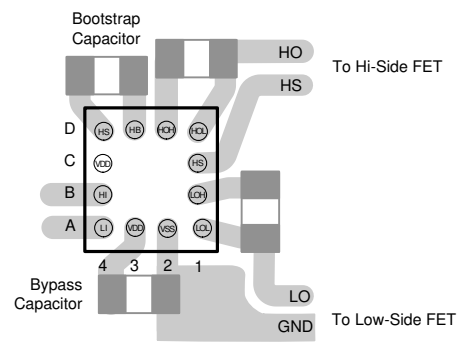


Figure 10-2. Layout Example with HOH and LOH Gate Resistors

11 Device and Documentation Support

11.1 Device Support

11.1.1 Third-Party Products Disclaimer

TI'S PUBLICATION OF INFORMATION REGARDING THIRD-PARTY PRODUCTS OR SERVICES DOES NOT CONSTITUTE AN ENDORSEMENT REGARDING THE SUITABILITY OF SUCH PRODUCTS OR SERVICES OR A WARRANTY, REPRESENTATION OR ENDORSEMENT OF SUCH PRODUCTS OR SERVICES, EITHER ALONE OR IN COMBINATION WITH ANY TI PRODUCT OR SERVICE.

11.2 Documentation Support

11.2.1 Related Documentation

For related documentation see the following:

- [AN-1112 DSBGA Wafer Level Chip Scale Package](#)
- [Using the LMG1205HBEVM GaN Half-Bridge EVM](#)

11.3 Receiving Notification of Documentation Updates

To receive notification of documentation updates, navigate to the device product folder on ti.com. Click on *Subscribe to updates* to register and receive a weekly digest of any product information that has changed. For change details, review the revision history included in any revised document.

11.4 Support Resources

TI E2E™ [support forums](#) are an engineer's go-to source for fast, verified answers and design help — straight from the experts. Search existing answers or ask your own question to get the quick design help you need.

Linked content is provided "AS IS" by the respective contributors. They do not constitute TI specifications and do not necessarily reflect TI's views; see TI's [Terms of Use](#).

11.5 Trademarks

TI E2E™ is a trademark of Texas Instruments.

All trademarks are the property of their respective owners.

11.6 Electrostatic Discharge Caution



This integrated circuit can be damaged by ESD. Texas Instruments recommends that all integrated circuits be handled with appropriate precautions. Failure to observe proper handling and installation procedures can cause damage.

ESD damage can range from subtle performance degradation to complete device failure. Precision integrated circuits may be more susceptible to damage because very small parametric changes could cause the device not to meet its published specifications.

11.7 Glossary

[TI Glossary](#) This glossary lists and explains terms, acronyms, and definitions.

Mechanical, Packaging, and Orderable Information

The following pages include mechanical, packaging, and orderable information. This information is the most current data available for the designated devices. This data is subject to change without notice and revision of this document. For browser-based versions of this datasheet, refer to the left-hand navigation.

PACKAGING INFORMATION

Orderable part number	Status (1)	Material type (2)	Package Pins	Package qty Carrier	RoHS (3)	Lead finish/ Ball material (4)	MSL rating/ Peak reflow (5)	Op temp (°C)	Part marking (6)
LMG1205YFXR	Active	Production	DSBGA (YFX) 12	3000 LARGE T&R	Yes	SNAGCU	Level-1-260C-UNLIM	-40 to 125	1205
LMG1205YFXR.A	Active	Production	DSBGA (YFX) 12	3000 LARGE T&R	Yes	SNAGCU	Level-1-260C-UNLIM	-40 to 125	1205
LMG1205YFXT	Active	Production	DSBGA (YFX) 12	250 SMALL T&R	Yes	SNAGCU	Level-1-260C-UNLIM	-40 to 125	1205
LMG1205YFXT.A	Active	Production	DSBGA (YFX) 12	250 SMALL T&R	Yes	SNAGCU	Level-1-260C-UNLIM	-40 to 125	1205

⁽¹⁾ **Status:** For more details on status, see our [product life cycle](#).

⁽²⁾ **Material type:** When designated, preproduction parts are prototypes/experimental devices, and are not yet approved or released for full production. Testing and final process, including without limitation quality assurance, reliability performance testing, and/or process qualification, may not yet be complete, and this item is subject to further changes or possible discontinuation. If available for ordering, purchases will be subject to an additional waiver at checkout, and are intended for early internal evaluation purposes only. These items are sold without warranties of any kind.

⁽³⁾ **RoHS values:** Yes, No, RoHS Exempt. See the [TI RoHS Statement](#) for additional information and value definition.

⁽⁴⁾ **Lead finish/Ball material:** Parts may have multiple material finish options. Finish options are separated by a vertical ruled line. Lead finish/Ball material values may wrap to two lines if the finish value exceeds the maximum column width.

⁽⁵⁾ **MSL rating/Peak reflow:** The moisture sensitivity level ratings and peak solder (reflow) temperatures. In the event that a part has multiple moisture sensitivity ratings, only the lowest level per JEDEC standards is shown. Refer to the shipping label for the actual reflow temperature that will be used to mount the part to the printed circuit board.

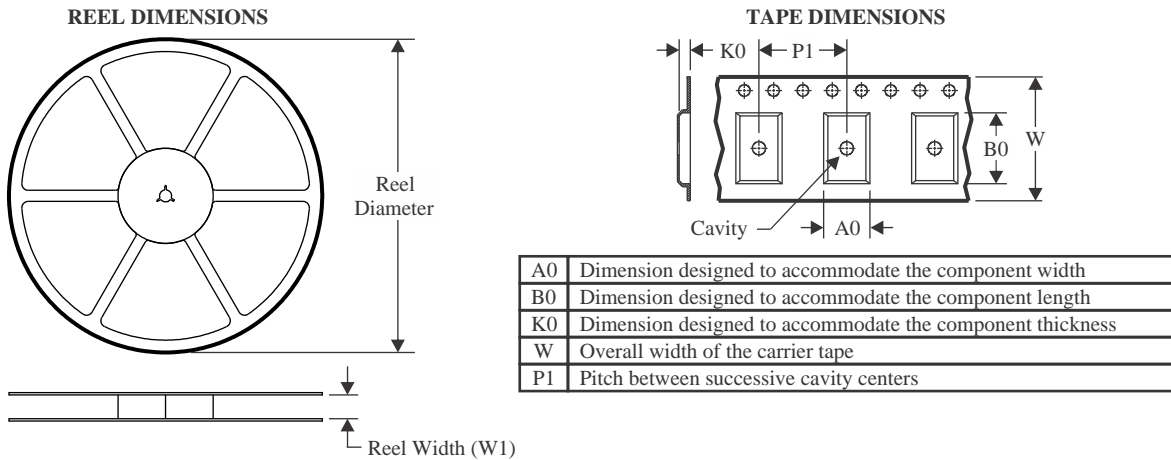
⁽⁶⁾ **Part marking:** There may be an additional marking, which relates to the logo, the lot trace code information, or the environmental category of the part.

Multiple part markings will be inside parentheses. Only one part marking contained in parentheses and separated by a "~" will appear on a part. If a line is indented then it is a continuation of the previous line and the two combined represent the entire part marking for that device.

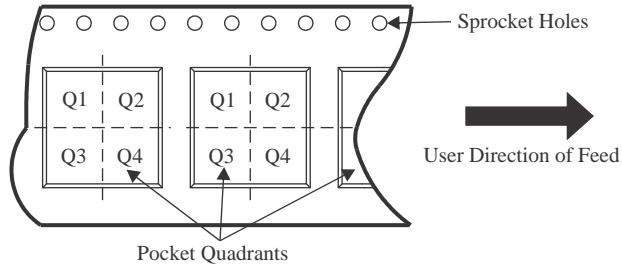
Important Information and Disclaimer: The information provided on this page represents TI's knowledge and belief as of the date that it is provided. TI bases its knowledge and belief on information provided by third parties, and makes no representation or warranty as to the accuracy of such information. Efforts are underway to better integrate information from third parties. TI has taken and continues to take reasonable steps to provide representative and accurate information but may not have conducted destructive testing or chemical analysis on incoming materials and chemicals. TI and TI suppliers consider certain information to be proprietary, and thus CAS numbers and other limited information may not be available for release.

In no event shall TI's liability arising out of such information exceed the total purchase price of the TI part(s) at issue in this document sold by TI to Customer on an annual basis.

TAPE AND REEL INFORMATION



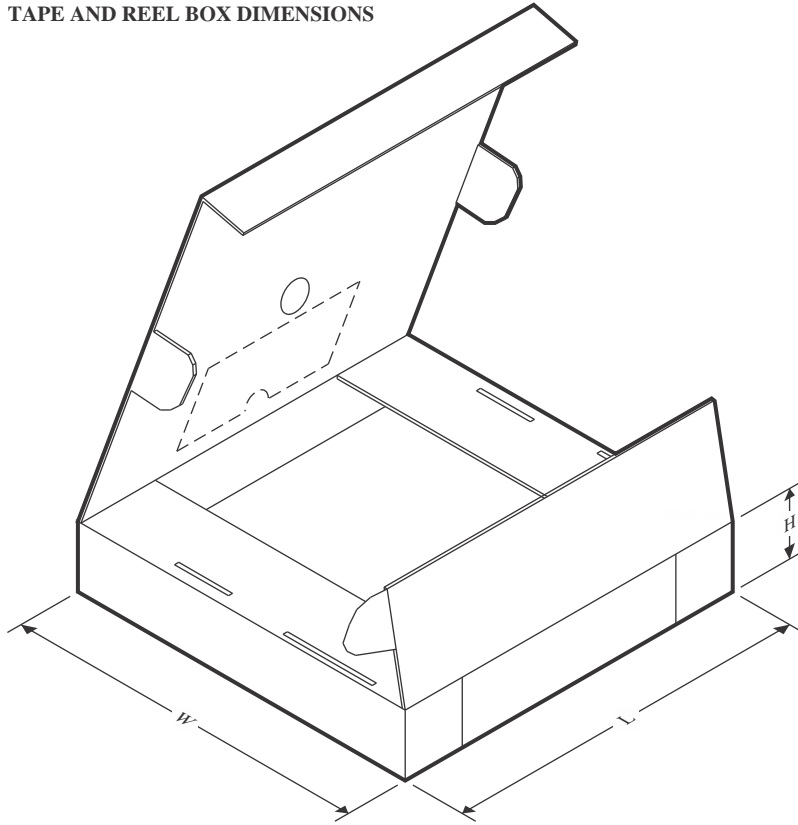
QUADRANT ASSIGNMENTS FOR PIN 1 ORIENTATION IN TAPE



*All dimensions are nominal

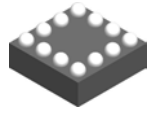
Device	Package Type	Package Drawing	Pins	SPQ	Reel Diameter (mm)	Reel Width W1 (mm)	A0 (mm)	B0 (mm)	K0 (mm)	P1 (mm)	W (mm)	Pin1 Quadrant
LMG1205YFXR	DSBGA	YFX	12	3000	178.0	8.4	1.85	2.01	0.76	4.0	8.0	Q1
LMG1205YFXT	DSBGA	YFX	12	250	178.0	8.4	1.85	2.01	0.76	4.0	8.0	Q1

TAPE AND REEL BOX DIMENSIONS



*All dimensions are nominal

Device	Package Type	Package Drawing	Pins	SPQ	Length (mm)	Width (mm)	Height (mm)
LMG1205YFXR	DSBGA	YFX	12	3000	208.0	191.0	35.0
LMG1205YFXT	DSBGA	YFX	12	250	208.0	191.0	35.0

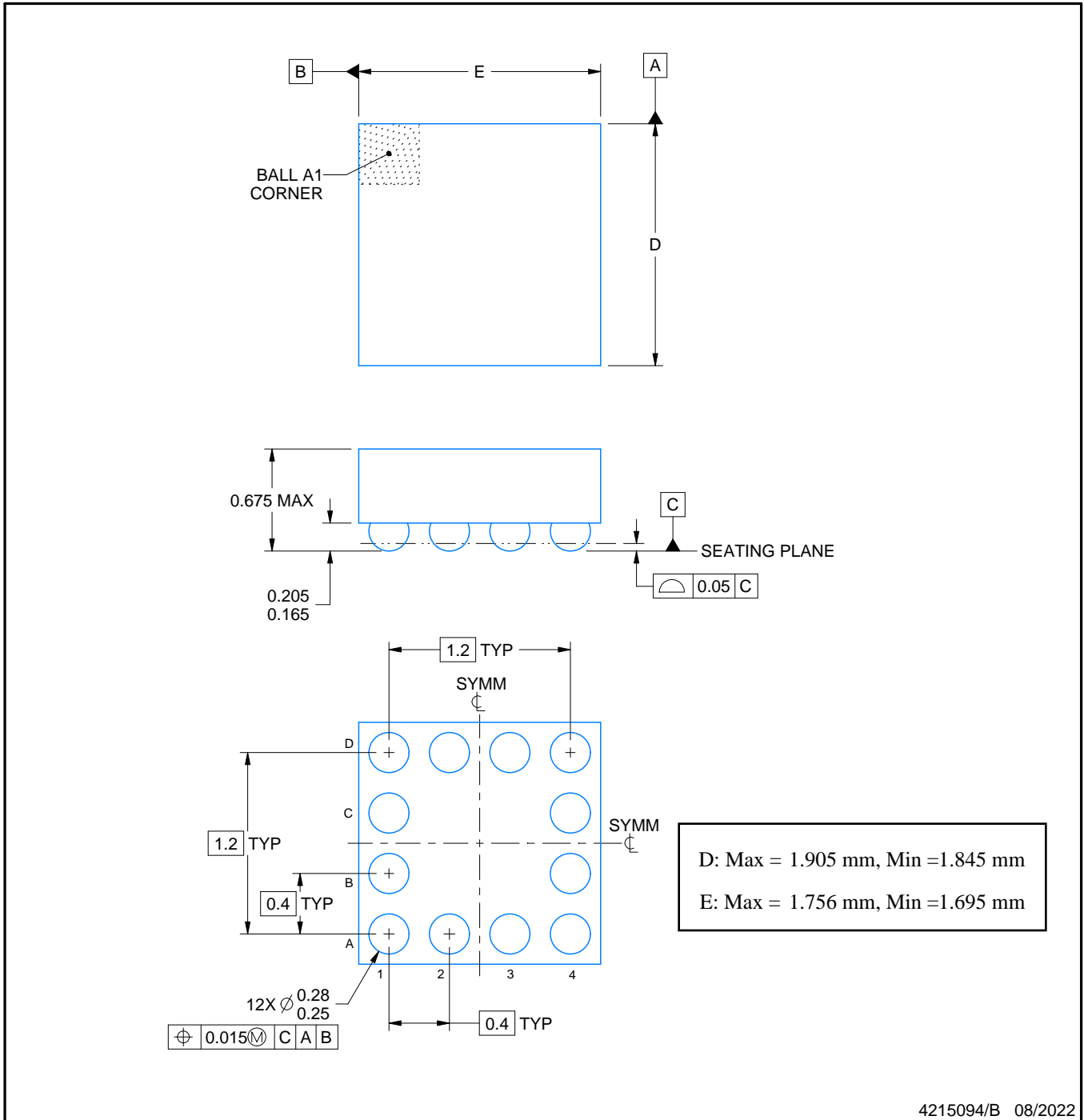


PACKAGE OUTLINE

YFX0012

DSBGA - 0.675 mm max height

DIE SIZE BALL GRID ARRAY



NOTES:

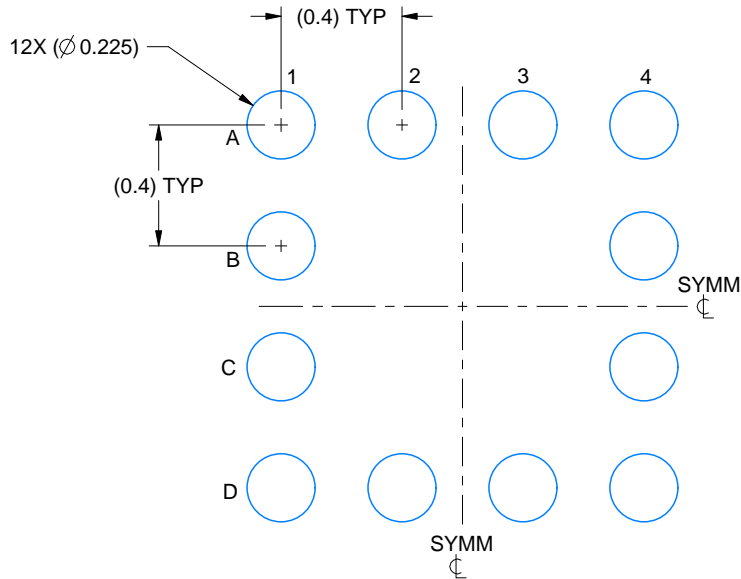
1. All linear dimensions are in millimeters. Any dimensions in parenthesis are for reference only. Dimensioning and tolerancing per ASME Y14.5M.
2. This drawing is subject to change without notice.

EXAMPLE BOARD LAYOUT

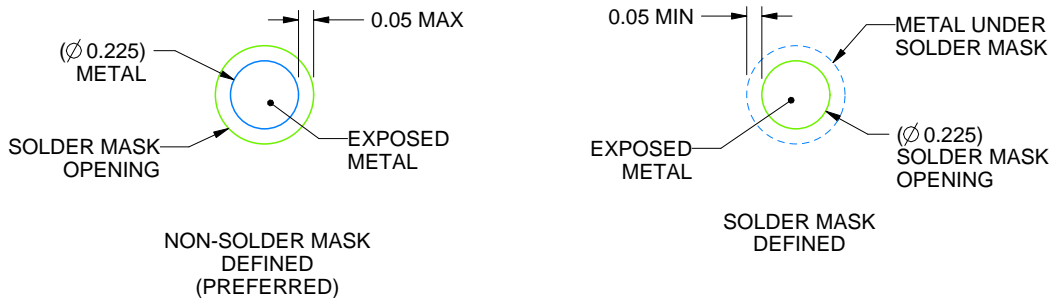
YFX0012

DSBGA - 0.675 mm max height

DIE SIZE BALL GRID ARRAY



LAND PATTERN EXAMPLE
EXPOSED METAL SHOWN
SCALE: 40X



SOLDER MASK DETAILS
NOT TO SCALE

4215094/B 08/2022

NOTES: (continued)

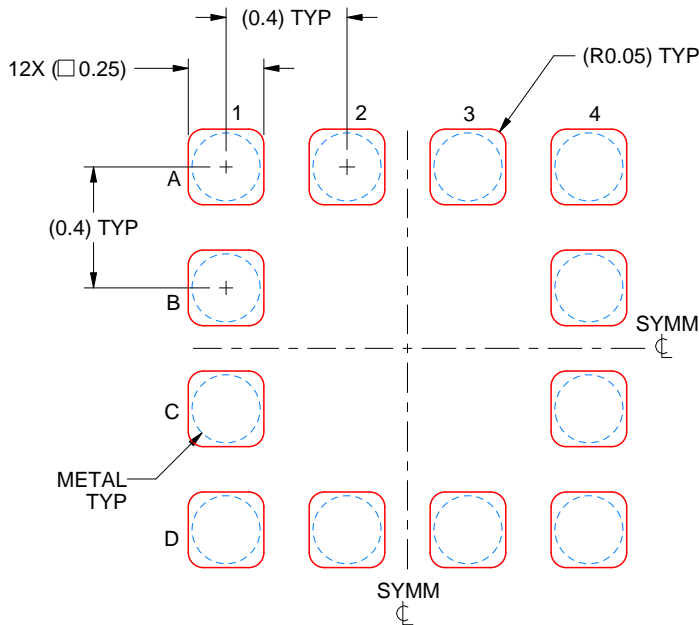
- 3. Final dimensions may vary due to manufacturing tolerance considerations and also routing constraints. See Texas Instruments Literature No. SNVA009 (www.ti.com/lit/snva009).

EXAMPLE STENCIL DESIGN

YFX0012

DSBGA - 0.675 mm max height

DIE SIZE BALL GRID ARRAY



SOLDER PASTE EXAMPLE
 BASED ON 0.1 mm THICK STENCIL
 SCALE: 40X

4215094/B 08/2022

NOTES: (continued)

- 4. Laser cutting apertures with trapezoidal walls and rounded corners may offer better paste release.

IMPORTANT NOTICE AND DISCLAIMER

TI PROVIDES TECHNICAL AND RELIABILITY DATA (INCLUDING DATASHEETS), DESIGN RESOURCES (INCLUDING REFERENCE DESIGNS), APPLICATION OR OTHER DESIGN ADVICE, WEB TOOLS, SAFETY INFORMATION, AND OTHER RESOURCES "AS IS" AND WITH ALL FAULTS, AND DISCLAIMS ALL WARRANTIES, EXPRESS AND IMPLIED, INCLUDING WITHOUT LIMITATION ANY IMPLIED WARRANTIES OF MERCHANTABILITY, FITNESS FOR A PARTICULAR PURPOSE OR NON-INFRINGEMENT OF THIRD PARTY INTELLECTUAL PROPERTY RIGHTS.

These resources are intended for skilled developers designing with TI products. You are solely responsible for (1) selecting the appropriate TI products for your application, (2) designing, validating and testing your application, and (3) ensuring your application meets applicable standards, and any other safety, security, regulatory or other requirements.

These resources are subject to change without notice. TI grants you permission to use these resources only for development of an application that uses the TI products described in the resource. Other reproduction and display of these resources is prohibited. No license is granted to any other TI intellectual property right or to any third party intellectual property right. TI disclaims responsibility for, and you fully indemnify TI and its representatives against any claims, damages, costs, losses, and liabilities arising out of your use of these resources.

TI's products are provided subject to [TI's Terms of Sale](#), [TI's General Quality Guidelines](#), or other applicable terms available either on [ti.com](#) or provided in conjunction with such TI products. TI's provision of these resources does not expand or otherwise alter TI's applicable warranties or warranty disclaimers for TI products. Unless TI explicitly designates a product as custom or customer-specified, TI products are standard, catalog, general purpose devices.

TI objects to and rejects any additional or different terms you may propose.

Copyright © 2026, Texas Instruments Incorporated

Last updated 10/2025

OUR CERTIFICATE

DiGi provide top-quality products and perfect service for customer worldwide through standardization, technological innovation and continuous improvement. DiGi through third-party certification, we stricly control the quality of products and services. Welcome your RFQ to

Email: Info@DiGi-Electronics.com



Tel: +00 852-30501935

RFQ Email: Info@DiGi-Electronics.com

DiGi is a global authorized distributor of electronic components.