

LMH1219RTWT Datasheet

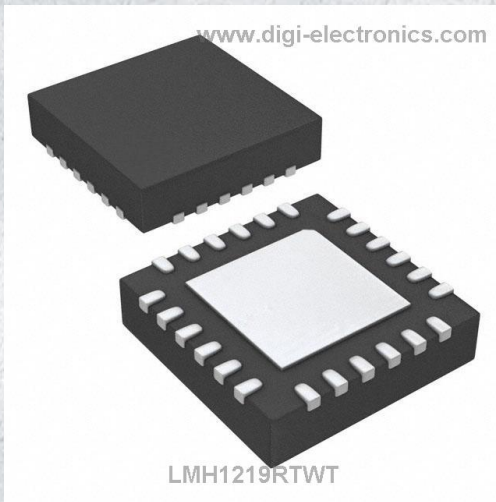

<https://www.DiGi-Electronics.com>

DiGi Electronics Part Number	LMH1219RTWT-DG
Manufacturer	Texas Instruments
Manufacturer Product Number	LMH1219RTWT
Description	IC INTERFACE SPECIALIZED 24WQFN
Detailed Description	Cable Equalization Interface 24-WQFN (4x5)



Tel: +00 852-30501935

RFQ Email: Info@DiGi-Electronics.com

DiGi is a global authorized distributor of electronic components.

Purchase and inquiry

Manufacturer Product Number:

LMH1219RTWT

Series:

-

Applications:

Cable Equalization

Voltage - Supply:

-

Supplier Device Package:

24-WQFN (4x5)

Base Product Number:

LMH1219

Manufacturer:

Texas Instruments

Product Status:

Active

Interface:

Serial

Package / Case:

24-WFQFN Exposed Pad

Mounting Type:

Surface Mount

Environmental & Export classification

RoHS Status:

ROHS3 Compliant

REACH Status:

REACH Unaffected

HTSUS:

8542.39.0001

Moisture Sensitivity Level (MSL):

3 (168 Hours)

ECCN:

EAR99

LMH1219 Low Power 12G UHD Adaptive Cable Equalizer with Integrated Reclocker

1 Features

- Supports ST-2082-1(12G), ST-2081-1(6G), ST-424(3G), ST-292(HD), and ST-259(SD)
- Supports SFF8431 (SFP+) for SMPTE 2022-5/6
- Compatible with DVB-ASI and AES10 (MADI)
- Integrated Reference-Less Reclocker Locks to SMPTE and 10GbE Rate: 11.88 Gbps, 5.94 Gbps, 2.97 Gbps, 1.485 Gbps, or Divide-by-1.001 Sub-Rates, 270 Mbps and 10.3125 Gbps
- Adaptive Cable Equalizer at Input 0 (IN0)
- Cable Reach (Belden 1694A):
 - 75 m at 11.88 Gbps (4Kp60 UHD)
 - 120 m at 5.94 Gbps (UHD)
 - 200 m at 2.97 Gbps (FHD)
 - 280 m at 1.485 Gbps (HD)
 - 600 m at 270 Mbps (SD)
- Adaptive Board Trace Equalizer at Input 1 (IN1)
- Low Power: 250 mW (Typical)
- Power Saving Mode: 16 mW
- Integrated Input Return Loss Network
- 2:1 Input Mux, 1:2 Fanout Output With De-Emphasis
- Supports Signal Splitter Mode (–6 dB Launch Amplitude)
- On-Chip Loop Filter Capacitor and Eye Monitor
- Powers from Single 2.5 V with On-Chip 1.8 V Regulator
- Configurable by Control Pins, SPI, or SMBus Interface
- 4 mm × 4 mm 24-pin QFN Package
- Operating Temperature Range: –40°C to +85°C

2 Applications

- SMPTE Compatible Serial Digital Interface
- UHDTV/4K/8K/HDTV/SDTV Video
- Broadcast Video Routers, Switchers, Distribution Amplifiers, and Monitors
- Digital Video Processing and Editing
- 10 GbE - SDI Media Gateway

3 Description

The LMH1219 is a low-power, dual-input and dual-output, adaptive equalizer with integrated reclocker. It supports SMPTE video rates up to 11.88 Gbps and 10 GbE video over IP, enabling UHD video for 4K/8K applications. An extended reach adaptive cable equalizer at IN0 is designed to equalize data transmitted over 75 Ω coaxial cable and operates over a wide range of data rates from 125 Mbps to 11.88 Gbps. An adaptive board trace equalizer at IN1 is SFF-8431 compatible and supports both SMPTE and 10 GbE data rates.

The integrated reclocker attenuates high frequency jitter and provides the best signal integrity. High input jitter tolerance of the reclocker improves timing margin. The reclocker has a built-in loop filter, and operates without the need of a precision input reference clock. A non-disruptive eye monitor allows real time measurement of the serial data to simplify system debug and accelerate board bring-up.

The integrated 2:1 Mux and 1:2 Fanout provide flexibility for multiple video signals. The output drivers offer programmable de-emphasis to compensate board trace losses at its outputs. The integrated return loss network meets stringent SMPTE specifications across all data rates. The typical power consumption of LMH1219 is 250 mW. In the absence of input signal, power is further reduced to 16 mW.

The LMH1219 is pin compatible to LMH1226 (12G UHD reclocker) and LMH0324 (3G adaptive cable equalizer).

Device Information⁽¹⁾

PART NUMBER	PACKAGE	BODY SIZE (NOM)
LMH1219	QFN (24)	4.00 mm × 4.00 mm

(1) For all available packages, see the orderable addendum at the end of the data sheet.

Simplified Block Diagram

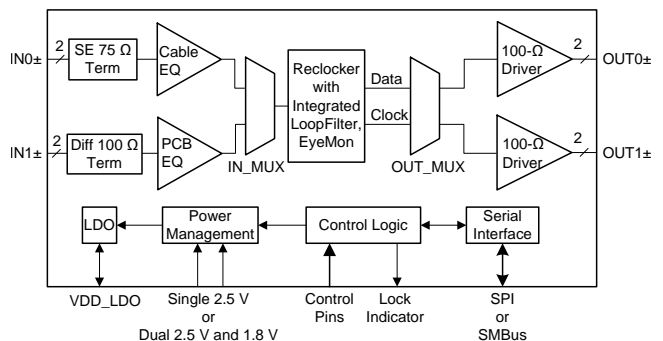

Table of Contents

1 Features	1	7.3 Feature Description	17
2 Applications	1	7.4 Device Functional Modes	22
3 Description	1	7.5 LMH1219 Register Map	27
4 Revision History	2	8 Application and Implementation	40
5 Pin Configuration and Functions	3	8.1 Application Information	40
6 Specifications	5	8.2 Typical Application	40
6.1 Absolute Maximum Ratings	5	9 Power Supply Recommendations	47
6.2 ESD Ratings	5	10 Layout	47
6.3 Recommended Operating Conditions	5	10.1 PCB Layout Guidelines	47
6.4 Thermal Information	6	10.2 Layout Example	49
6.5 Electrical Characteristics	6	11 Device and Documentation Support	50
6.6 Recommended SMBus Interface AC Timing Specifications	12	11.1 Receiving Notification of Documentation Updates	50
6.7 Serial Parallel Interface (SPI) AC Timing Specifications	13	11.2 Community Resources	50
6.8 Typical Characteristics	14	11.3 Trademarks	50
7 Detailed Description	16	11.4 Electrostatic Discharge Caution	50
7.1 Overview	16	11.5 Glossary	50
7.2 Functional Block Diagram	16	12 Mechanical, Packaging, and Orderable Information	50

4 Revision History

Changes from Revision C (October 2017) to Revision D	Page
• First public release of full production data sheet; add top navigator link for TI reference design	1
• Moved LMH1219 and LMH0324 Compatibility to Application Information	40

Changes from Revision B (February 2017) to Revision C	Page
• add package drawings	50

Changes from Revision A (May 2016) to Revision B	Page
• Changed eq_en_bypass bit description from "Gain Stages 3 and 4" to "Gain Stages 2 and 3"	29
• Changed bit location of IN1 Carrier Detect Power Down Control from Reg 0x13[5] to Reg 0x15[6]	29

Changes from Original (April 2016) to Revision A	Page
• Deleted min and max VOD_DE amplitude specification when VOD_DE = Level F	9
• Changed typical VOD_DE amplitude specifications for Levels F, R, and L	9
• Changed DEM value and DEM register settings in Table 5 to match correct VOD_DE pin logic levels	20
• Added new row for VOD = 5, DEM = 5 setting in Table 10	43

5 Pin Configuration and Functions

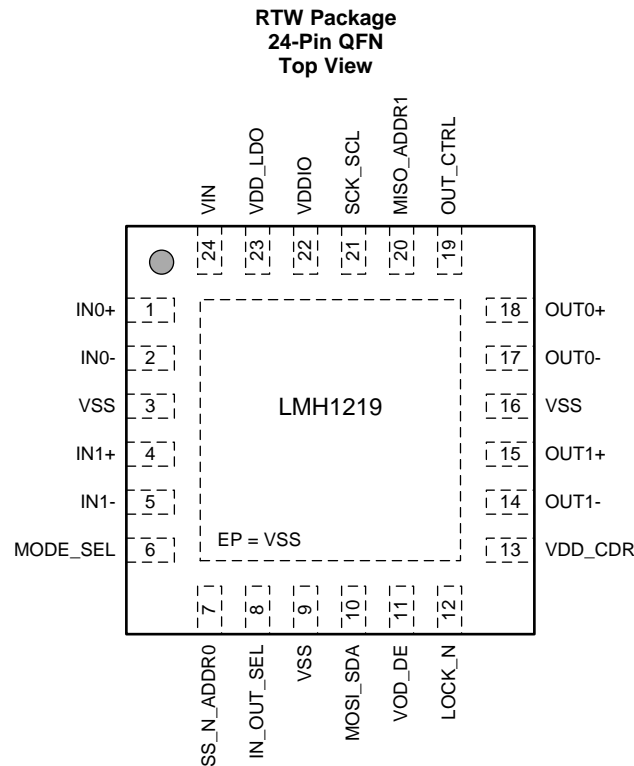

Pin Functions

PIN		I/O ⁽¹⁾	DESCRIPTION
NAME	NO.		
High Speed Differential I/O'S			
IN0+	1	I, Analog	Single-ended complementary inputs, 75-Ω internal termination from IN0+ or IN0- to internal common mode voltage and return loss compensation network. Requires external 4.7-μF AC coupling capacitors. IN0+ is the 75-Ω input port for the adaptive cable equalizer in SMPTE video applications.
IN0-	2	I, Analog	
IN1+	4	I, Analog	Differential complementary inputs with internal 100-Ω termination. Requires external 4.7-μF AC coupling capacitors for SMPTE and 10 GbE.
IN1-	5	I, Analog	
OUT0+	18	O, Analog	Differential complementary outputs with 100-Ω internal termination. Requires external 4.7-μF AC coupling capacitors. Output driver OUT0± can be disabled under user control.
OUT0-	17	O, Analog	
OUT1+	15	O, Analog	Differential complementary outputs with 100-Ω internal termination. Requires external 4.7-μF AC coupling capacitors. Output driver OUT1± can be disabled under user control.
OUT1-	14	O, Analog	
Control Pins			
LOCK_N	12	O, LVCMOS, OD	LOCK_N is the reclocker lock indicator for the selected input. LOCK_N is pulled LOW when the reclocker has acquired locking condition. LOCK_N is an open drain output, 3.3 V tolerant, and requires an external 2-kΩ to 5-kΩ pull-up resistor to logic supply. LOCK_N pin can be re-configured to indicate CD_N (Carrier Detect) or INT_N (Interrupt) for IN0 or IN1 through register programming.
IN_OUT_SEL	8	I, 4-LEVEL	IN_OUT_SEL selects the signal flow at input ports to output ports. See Table 2 for details. This pin setting can be overridden by register control.
OUT_CTRL	19	I, 4-LEVEL	OUT_CTRL selects the signal flow from the selected IN port to OUT0± and OUT1±. It selects reclocked data, reclocked data and clock, bypassed reclocker data (equalized data to output driver), or bypassed equalizer and reclocker data. See Table 4 for details. This pin setting can be overridden by register control.

(1) I = Input, O = Output, IO = Input or Output, OD = Open Drain, LVCMOS = 2-State Logic, 4-LEVEL = 4-State Logic

LMH1219

SNLS530D – APRIL 2016 – REVISED JUNE 2018

www.ti.com

Pin Functions (continued)

PIN		I/O ⁽¹⁾	DESCRIPTION
NAME	NO.		
VOD_DE	11	I, 4-LEVEL	VOD_DE selects the driver output amplitude and de-emphasis level for both OUT0± and OUT1±. See Table 5 for details. This pin setting can be overridden by register control.
MODE_SEL	6	I, 4-LEVEL	MODE_SEL enables SPI or SMBus serial control interface. See Table 6 for details.
Serial Control Interface (SPI Mode), MODE_SEL = F (Float)			
SS_N	7	I, LVCMOS	SS_N is the Slave Select. When SS_N is at logic Low, it enables SPI access to the LMH1219 slave device. SS_N is a LVCMOS input referenced to VDDIO.
MISO	20	O, LVCMOS	MISO is the SPI control serial data output from the LMH1219 slave device. MISO is a LVCMOS output referenced to VDDIO.
MOSI	10	I, LVCMOS	MOSI is used as the SPI control serial data input to the LMH1219 slave device. MOSI is LVCMOS input referenced to VDDIO.
SCK	21	I, LVCMOS	SCK is the SPI serial input clock to the LMH1219 slave device. SCK is LVCMOS referenced to VDDIO.
Serial Control Interface (SMBus MODE) , MODE_SEL = L (1 kΩ to VSS)			
ADDR0	7	Strap, 4-LEVEL	ADDR[1:0] are SMBus address straps to select one of the 16 supported SMBus addresses. ADDR[1:0] are 4-level straps and are read into the device at power up.
ADDR1	20	Strap, 4-LEVEL	
SDA	10	IO, LVCMOS, OD	SDA is the SMBus bi-directional open drain SDA data line to or from the LMH1219 slave device. SDA is an open drain IO and tolerant to 3.3 V. SDA requires an external 2-kΩ to 5-kΩ pull-up resistor to the SMBus termination voltage.
SCL	21	I, LVCMOS, OD	SCL is the SMBus input clock to the LMH1219 slave device. It is driven by a LVCMOS open drain driver from the SMBus master. SCL is tolerant to 3.3 V and requires an external 2-kΩ to 5-kΩ pull up resistor to the SMBus termination voltage.
Power			
VSS	3, 9, 16	I, Ground	Ground reference.
VIN	24	I, Power	VIN is connected to an external power supply. It accepts either 2.5 V ± 5% or 1.8 V ± 5%. When VIN is powered from 2.5 V, VDD_LDO is the output of an on-chip LDO regulator. For lower power operation, both VIN and VDD_LDO should be connected to a 1.8 V supply.
VDDIO	22	I, Power	VDDIO powers the LVCMOS IO and 4-level input logic and connects to 2.5 V ± 5%.
VDD_LDO	23	IO, Power	VDD_LDO is the output of the internal 1.8 V LDO regulator when VIN is connected to a 2.5 V supply. VDD_LDO output requires external 1-μF and 0.1-μF bypass capacitors to VSS. The internal LDO is designed to power internal circuitry only. VDD_LDO is an input when VIN is powered from 1.8 V for lower power operation. When VIN is connected to a 1.8 V supply, both VIN and VDD_LDO should be connected to a 1.8 V supply.
VDD_CDR	13	I, Power	VDD_CDR powers the reclocker circuitry and connects to 2.5 V ± 5% supply.
EP		I, Ground	EP is the exposed pad at the bottom of the QFN package. The exposed pad must be connected to the ground plane through a via array. See Figure 41 for details.

6 Specifications

6.1 Absolute Maximum Ratings

 over operating free-air temperature range (unless otherwise noted) ⁽¹⁾⁽²⁾

	MIN	MAX	UNIT
Supply Voltage for 2.5 V Mode (VDD_CDR, VIN, VDDIO)	-0.5	2.75	V
Supply Voltage for 1.8 V Mode (VIN, VDD_LDO)	-0.5	2.0	V
4-Level Input/Output Voltage (IN_OUT_SEL, OUT_CTRL, VOD_DE, MODE_SEL, ADDR0, ADDR1)	-0.5	2.75	V
SMBus Input/Output Voltage (SDA, SCL)	-0.5	4.0	V
SPI Input/Output Voltage (SS_N, MISO, MOSI, and SCK)	-0.5	2.75	V
Input Voltage (IN0±, IN1±)	-0.5	2.75	V
Input Current (IN0±, IN1±)	-30	30	mA
Junction Temperature		125	°C
Storage temperature	-65	150	°C

- Stresses beyond those listed under *Absolute Maximum Ratings* may cause permanent damage to the device. These are stress ratings only, which do not imply functional operation of the device at these or any other conditions beyond those indicated under *Recommended Operating Conditions*. Exposure to absolute-maximum-rated conditions for extended periods may affect device reliability.
- For soldering specifications, see application note [SNOA549](#).

6.2 ESD Ratings

		VALUE	UNIT
V _(ESD) Electrostatic discharge	Human-body model (HBM), per ANSI/ESDA/JEDEC JS-001 ⁽¹⁾	±4500	V
	Charged-device model (CDM), per JEDEC specification JESD22-C101 ⁽²⁾	±1500	

- JEDEC document JEP155 states that 500 V HBM allows safe manufacturing with a standard ESD control process. Manufacturing with less than 500 V HBM is possible with the necessary precautions. Pins listed as ±4500 V may actually have higher performance.
- JEDEC document JEP157 states that 250 V CDM allows safe manufacturing with a standard ESD control process. Manufacturing with less than 250 V CDM is possible with the necessary precautions. Pins listed as ±1500 V may actually have higher performance.

6.3 Recommended Operating Conditions

over operating free-air temperature range (unless otherwise noted)

		MIN	NOM	MAX	UNIT	
Single Supply Mode ⁽¹⁾	VIN, VDDIO, VDD_CDR to VSS	2.375	2.5	2.625	V	
Dual Supply Mode ⁽²⁾⁽³⁾	VIN, VDD_LDO to VSS	1.71	1.8	1.89	V	
	VDD_CDR, VDDIO to VSS	2.375	2.5	2.625		
VDD _{SMBUS}	SMBus: SDA, SCL Open Drain Termination Voltage	2.375		3.6	V	
V _{INO_LAUNCH}	Source Launch Amplitude before coaxial cable	Normal mode	0.72	0.8	0.88	Vp-p
		Splitter mode	0.36	0.4	0.44	
V _{IN1_LAUNCH}	Source Differential Launch Amplitude	before 5-inch board trace	300		850	mVp-p
		before 20-inch board trace	650		1000	
T _{JUNCTION}	Operating Junction Temperature			100	°C	
T _{AMBIENT}	Ambient Temperature	-40	25	85	°C	
NT _{ps_max} ⁽⁴⁾	Maximum Supply Noise Tolerance	50 Hz to 1 MHz, sinusoidal		<20	mVp-p	
		1.1 MHz to 6 GHz, sinusoidal		<10		

- In Single Supply Mode, the VIN, VDDIO and VDD_CDR supplies are 2.5 V. The VDD_LDO is the 1.8 V LDO output of an internal LDO regulator, the VDD_LDO pin should not be connected to any external supply voltage.
- In Dual Supply Mode, the VIN and VDD_LDO are connected to a 1.8 V supply, while the VDD_CDR and VDDIO supplies are 2.5 V.
- In Dual Supply Mode, the VDDIO and VDD_CDR supply should be powered before or at the same time as VIN and VDD_LDO = 1.8 V.
- The sum of the DC supply voltage and AC supply noise should not exceed the recommended supply voltage range.

LMH1219

SNLS530D – APRIL 2016 – REVISED JUNE 2018

www.ti.com**6.4 Thermal Information**

THERMAL METRIC ⁽¹⁾⁽²⁾		LMH1219	
		RTW (QFN)	UNIT
		24 PINS	
$R_{\theta JA}$	Junction-to-ambient thermal resistance	33.2	°C/W
$R_{\theta JC(top)}$	Junction-to-case (top) thermal resistance	28.8	°C/W
$R_{\theta JB}$	Junction-to-board thermal resistance	11.2	°C/W
ψ_{JT}	Junction-to-top characterization parameter	0.3	°C/W
ψ_{JB}	Junction-to-board characterization parameter	11.3	°C/W
$R_{\theta JC(bot)}$	Junction-to-case (bottom) thermal resistance	2.2	°C/W

(1) For more information about traditional and new thermal metrics, see the *Semiconductor and IC Package Thermal Metrics* application report ([SPRA953](#)).

(2) No heat sink is assumed for these estimations. Depending on the application, a heat sink, faster air flow, and/or reduced ambient temperature (< 85°C) may be required to maintain the maximum junction temperature specified in [Electrical Characteristics](#).

6.5 Electrical Characteristics

over operating free-air temperature range (unless otherwise noted)

PARAMETER		CONDITIONS	MIN	TYP	MAX	UNIT
POWER						
$P_{D_{DUAL}}$	Power Dissipation, Dual Supply Mode	Measured with PRBS-10, Locked to 11.88 Gbps at IN0+, VOD = default, only OUT0 enabled		250		mW
P_{DZ_DUAL}	Power Dissipation, Dual Supply Mode	Power Save Mode, no input signal		16		mW
$P_{D_{SINGLE}}$	Power Dissipation, Single Supply Mode	Measured with PRBS-10, Locked to 11.88 Gbps at IN0+, VOD = default, only OUT0 enabled		290		mW
P_{DZ_SINGLE}	Power Dissipation, Single Supply Mode	Power Save Mode, no input signal		27		mW
$I_{DD_{DUAL}}$	Current Consumption, Dual Supply Mode	Measured at 2.5 V supply with PRBS-10, Locked to 11.88 Gbps at IN0+, VOD = Default, only OUT0 enabled		64	70	mA
		Measured at 1.8 V supply with PRBS-10, Locked to 11.88 Gbps at IN0+, VOD = Default, only OUT0 enabled		50	62	
I_{DDZ_DUAL}	Current Consumption, Dual Supply Mode	Forced Power Save Mode, MODE_SEL = LEVEL-H, Measured at 2.5 V supply		4	5	mA
		Forced Power Save Mode, MODE_SEL = LEVEL-H, Measured at 1.8 V supply		3	9	
$I_{DD_{TRANS_DUAL}}$	Current Consumption, Dual Supply Mode Acquiring Lock, HEO/VEO Lock Monitor Disabled	Measured at 2.5 V supply with PRBS-10, IN1±, Acquiring Lock VOD = Default, OUT0 and OUT1 enabled		90	101	mA
		Measured at 1.8 V supply with PRBS-10, IN1±, Acquiring Lock VOD = Default, OUT0 and OUT1 enabled		30	37	
$V_{DD_{LDO}}$	LDO 1.8 V Output Voltage	VIN = 2.5 V, Single Supply Mode	1.71	1.8	1.89	V

Electrical Characteristics (continued)

over operating free-air temperature range (unless otherwise noted)

PARAMETER	CONDITIONS	MIN	TYP	MAX	UNIT	
LVC MOS DC SPECIFICATIONS						
V _{IH}	High Level Input Voltage	2-Level Input (SS_N, SCK, MOSI), VDDIO = 2.5 V	0.7 × VDDIO	VDDIO + 0.3	V	
		2-Level Input (SCL, SDA), VDDIO = 2.5 V	0.7 × VDDIO	3.6		
V _{IL}	Low Level Input Voltage	2-Level Input (SS_N, SCK, MOSI), VDDIO = 2.5 V	-0.3	0.3 × VDDIO	V	
		2-Level Input (SCL, SDA), VDDIO = 2.5 V	0	0.3 × VDDIO		
V _{OH}	High Level Output Voltage	I _{OH} = -2 mA, (MISO), VDDIO = 2.5 V	0.8 × VDDIO	VDDIO	V	
V _{OL}	Low Level Output Voltage	I _{OL} = 2 mA, (MISO), VDDIO = 2.5 V	0	0.2 × VDDIO	V	
		I _{OL} = 3 mA, (LOCK_N, SCL, SDA), VDDIO = 2.5 V		0.4		
I _{IH}	Input High Leakage Current	SPI Mode: LVC MOS (SS_N, SCK, MOSI), V _{input} = VDDIO		15	μA	
		SMBus Mode: LVC MOS (LOCK_N, SCL, SDA), V _{input} = VDDIO		10		
I _{IL}	Input Low Leakage Current	SPI Mode: LVC MOS (SS_N), V _{input} = VSS	-40		μA	
		SPI Mode: LVC MOS (SCK, MOSI), V _{input} = VSS	-15			
		SMBus Mode: LVC MOS (LOCK_N, SCL, SDA), V _{input} = VSS	-10			
4-LEVEL LOGIC DC SPECIFICATIONS (REFERENCE TO VDDIO, APPLY TO ALL 4-LEVEL INPUT CONTROL PINS)						
V _{4_LVL_H}	LEVEL-H Input Voltage	Pull-up 1 kΩ to VDDIO		VDDIO	V	
V _{4_LVL_F}	LEVEL-F Default Voltage	Float, VDDIO = 2.5 V		2/3 × VDDIO	V	
V _{4_LVL_R}	LEVEL-R Input Voltage	External Pull-down 20 kΩ to VSS, VDDIO = 2.5 V		1/3 × VDDIO	V	
V _{4_LVL_L}	LEVEL-L Input Voltage	External Pull-down 1 kΩ to VSS		0	V	
I _{4_LVL_IH}	Input High Leakage Current	4-Levels (IN_OUT_SEL, OUT_CTRL, VOD_DE, MODE_SEL), V _{input} = VDDIO	20	45	80	μA
		SMBus Mode: 4-Levels (ADDR0, ADDR1), V _{input} = VDDIO	20	45	80	
I _{4_LVL_IL}	Input Low Leakage Current	4-Levels (IN_OUT_SEL, OUT_CTRL, VOD_DE, MODE_SEL), V _{input} = VSS	-160	-93	-40	μA
		SMBus Mode: 4-Levels (ADDR0, ADDR1), V _{input} = VSS	-160	-93	-40	
RECEIVER SPECIFICATIONS (IN0+)						
R _{IN0_TERM}	DC Input Termination	IN0+ and IN0- to VSS	63	75	87	Ω
RL _{IN0_S11}	Input Return Loss Reference to 75 Ω ⁽¹⁾	S11, 5 MHz to 1.485 GHz		-20		dB
		S11, 1.485 GHz to 3 GHz		-18		
		S11, 3 GHz to 6 GHz		-13		
		S11, 6 GHz to 12 GHz		-6.5		
V _{IN0_CM}	IN0 DC Common Mode Voltage	Input common mode voltage at IN0+ or IN0- to VSS		1.4		V

(1) This parameter was measured with an LMH1219EVM.

LMH1219

SNLS530D – APRIL 2016 – REVISED JUNE 2018

www.ti.com

Electrical Characteristics (continued)

over operating free-air temperature range (unless otherwise noted)

PARAMETER	CONDITIONS	MIN	TYP	MAX	UNIT
V _{WANDER} Input DC Wander	SD, signal at IN0+, Input launch amplitude = 0.8 Vp-p		100		mVp-p
	HD, 3G, 6G, 12G, signal at IN0+, Input launch amplitude = 0.8 Vp-p		50		
RECEIVER SPECIFICATIONS (IN1±)					
R _{IN1_TERM} DC Input Differential Termination	Measured across IN1+ to IN1-	80	100	120	Ω
R _{LIN1_SDD11} Input Differential Return Loss ⁽¹⁾	SDD11, 10 MHz - 2.8 GHz		-21		dB
	SDD11, 2.8 GHz - 6 GHz		-17		
	SDD11, 6 GHz - 11.1 GHz		-8		
R _{LIN1_SCD11} Differential to Common Mode Conversion ⁽¹⁾	SCD11, 10 MHz to 11.1 GHz		-23		dB
V _{IN1_CM_TOL} Input AC Common Mode Voltage Tolerance			15		mV (rms)
V _{IN1_CM} IN1 DC Common Mode Voltage	Input common mode voltage at IN1+ or IN1- to VSS		2.06		V
C _{DON_IN1} CD_N = LOW, Carrier Detect (Default) Assert ON Threshold Level for input voltage	10.3125 Gbps, 1010 Clock Pattern		39		mVp-p
	10.3125 Gbps, PRBS-31 Pattern		25		
	11.88 Gbps, EQ and PLL Pathological Pattern		20		
C _{DOFF_IN1} CD_N = HIGH, Carrier Detect (Default) De-Assert OFF Threshold Level	10.3125 Gbps, 1010 Clock Pattern		15		mVp-p
	10.3125 Gbps, PRBS-31 Pattern		15		
	11.88 Gbps, EQ and PLL Pathological Pattern		18		

Electrical Characteristics (continued)

over operating free-air temperature range (unless otherwise noted)

PARAMETER	CONDITIONS	MIN	TYP	MAX	UNIT	
TRANSMITTER OUTPUT (OUT0± AND OUT1±)						
VOD	Output Differential Voltage ⁽²⁾	8T pattern, VOD_DE = LEVEL-H, see Figure 13 SD, HD, 3G, 6G, 12G, and 10 GbE		410		mVp-p
		8T pattern, VOD_DE = LEVEL-F, see Figure 13 SD, HD, 3G, 6G, 12G, and 10 GbE	485	560	620	
		8T pattern, VOD_DE = LEVEL-R, see Figure 13 SD, HD, 3G, 6G, 12G, and 10 GbE		635		
		8T pattern, VOD_DE = LEVEL-L, see Figure 13 SD, HD, 3G, 6G, 12G, and 10 GbE		810		
VOD _{DE}	De-emphasized Output Differential Voltage ⁽²⁾	8T pattern, VOD_DE = LEVEL-H, see Figure 13 SD, HD, 3G, 6G, 12G, and 10 GbE		410		mVp-p
		8T pattern, VOD_DE = LEVEL-F, see Figure 13 SD, HD, 3G, 6G, 12G, and 10 GbE		500		
		8T pattern, VOD_DE = LEVEL-R, see Figure 13 SD, HD, 3G, 6G, 12G, and 10 GbE		480		
		8T pattern, VOD_DE = LEVEL-L, see Figure 13 SD, HD, 3G, 6G, 12G, and 10 GbE		480		
R _{OUT_TERM}	DC Output Differential Termination	Measured across OUTn+ and OUTn-	80	100	120	Ω
t _R /t _F	Output Rise/Fall Time ⁽³⁾	20% - 80% using 8T Pattern SD, HD, 3G, 6G, 12G and 10 GbE, measured after 1 inch trace		45		ps
RL _{TX-SDD22}	Output Differential Return Loss Measured with the Device Powered Up and Outputs a 10-MHz Clock Signal ⁽³⁾	SDD22, 10 MHz - 2.8 GHz		-17		dB
		SDD22, 2.8 GHz - 6 GHz		-15		
		SDD22, 6 GHz - 11.1 GHz		-15		
RL _{TX-SCC22}	Output Common Mode Return Loss Measured with the Device Powered Up and Outputs a 10-MHz Clock Signal ⁽³⁾	SCC22, 10 MHz - 4.75 GHz		-12		dB
		SCC22, 4.75 GHz - 11.1 GHz		-12		
V _{TX_CM}	AC Common Mode Voltage ⁽³⁾	Default Setting, PRBS-31, 10.3125 Gbps		5		mV (rms)

(2) ATE production tested with DC method.

(3) This parameter was measured with an LMH1219EVM.

LMH1219

SNLS530D – APRIL 2016 – REVISED JUNE 2018

www.ti.com

Electrical Characteristics (continued)

over operating free-air temperature range (unless otherwise noted)

PARAMETER	CONDITIONS	MIN	TYP	MAX	UNIT	
OUTPUT JITTER						
T _J	Total Jitter (BER≤1e-12), Reclocked Output ⁽⁴⁾	11.88 Gbps, PRBS-10, TX launch amplitude = 720 mV, 75 m Belden 1694A at IN0+		0.11	0.15	UI
		5.94 Gbps, PRBS-10, TX launch amplitude = 720 mV, 120 m Belden 1694A at IN0+		0.106		UI
		2.97 Gbps, PRBS-10, TX launch amplitude = 720 mV, 200 m Belden 1694A at IN0+		0.075		UI
		1.485 Gbps, PRBS-10, TX launch amplitude = 720 mV, 300 m Belden 1694A at IN0+		0.07		UI
		270 Mbps, PRBS-10, TX launch amplitude = 720 mV, 600 m Belden 1694A at IN0+		0.07		UI
		10.3125 Gbps, PRBS-10, 500 mVp-p and 1000 mVp-p launch amplitude, 20 inch FR4 board trace at IN1±		0.09	0.15	UI
R _J	Random Jitter, Reclocked Output	11.88 Gbps, PRBS-10, TX launch amplitude = 720 mV, 75 m Belden 1694A at IN0+		5.7		mUI (rms)
		10.3125 Gbps, PRBS-10, 500 mVp-p and 1000 mVp-p launch amplitude, 20 inch FR4 board trace at IN1±		4.1		mUI (rms)
D _J	Deterministic Jitter, Reclocked Output	11.88 Gbps, PRBS-10, TX launch amplitude = 720 mV, 75 m Belden 1694A at IN0+		40		mUI
		10.3125 Gbps, PRBS-10, 500 mVp-p and 1000 mVp-p launch amplitude, 20 inch FR4 board trace at IN1±		34		mUI
T _{JRAW}	Total Jitter (BER≤1e-12), RAW (Reclocker Bypassed)	125 Mbps, PRBS-10, TX launch amplitude = 800 mV, 600 m Belden 1694A at IN0+		0.17		UI
		1.25 Gbps, PRBS-10, 500 mVp-p and 1000 mVp-p launch amplitude, 20 inch FR4 board trace at IN1±		0.17		

(4) These limits are ensured by bench characterization and are not production tested.

Electrical Characteristics (continued)

over operating free-air temperature range (unless otherwise noted)

PARAMETER	CONDITIONS	MIN	TYP	MAX	UNIT
CLOCK AND DATA RECOVERY					
LOCK _{RATE}	IN0+ Reclocker Lock Data Rates ⁽⁵⁾	SMPTE 12G, /1		11.88	Gbps
		SMPTE 12G, /1.001		11.868	Gbps
		SMPTE 6G, /1		5.94	Gbps
		SMPTE 6G, /1.001		5.934	Gbps
		SMPTE 3G, /1		2.97	Gbps
		SMPTE 3G, /1.001		2.967	Gbps
		SMPTE HD, /1		1.485	Gbps
		SMPTE HD, /1.001		1.4835	Gbps
		SMPTE SD, /1		270	Mbps
	IN1± Reclocker Lock Data Rate	10 GbE		10.3125	Gbps
BYPASS _{RATE}	IN0+ Bypass Reclocker Data Rate	MADI		125	Mbps
	IN1± Bypass Reclocker Data Rate	1 GbE		1.25	Gbps
BW _{PLL}	PLL Bandwidth	Measured with 0.2 UI SJ at –3 dB, 10.3125 Gbps		8	MHz
		Measured with 0.2 UI SJ at –3 dB, 11.88 Gbps		13	
		Measured with 0.2 UI SJ at –3 dB, 5.94 Gbps		7	
		Measured with 0.2 UI SJ at –3 dB, 2.97 Gbps		5	
		Measured with 0.2 UI SJ at –3 dB, 1.485 Gbps		3	
		Measured with 0.2 UI SJ at –3 dB, 270 Mbps		1	
J _{PEAKING}	PLL Jitter Peaking	SD, HD, 3G, 6G, 12G (IN0+), and 10 GbE (IN1±)		0.3	dB
J _{TOL_IN1}	IN1 Input Jitter Tolerance per SFF-8431 Appendix D.11	Total jitter tolerance combination of Dj, Pj, and Rj at 10 GbE, with RX stress eye mask Y1, Y2 limits		>0.7	UI
J _{TOL_IN0}	IN0 Input Jitter Tolerance with SJ	IN0+ EQ bypassed, Sinusoidal jitter, tested at 3G, 6G and 12G; SJ amplitude low to high sweep, tested at BER ≤ 1e-12		0.65	UI
T _{LOCK}	Reclocker Lock Time	All supported data rates, disable HEO/VEO monitor, IN0 EQ bypassed		5	ms
T _{ADAPT}	EQ Adapt Time	Adaptation Time for EQ at IN0		5	ms
TEMP _{LOCK}	VCO Lock with Temp Ramp	Lock Temperature Range (5°C per min, ramp up and down), –40°C to 85°C operating range, at 10.3125 Gbps and 11.88 Gbps		125	°C
T _{LATENCY}	Reclocker Latency ⁽⁶⁾	Adapt mode 0, All supported data rates, disable HEO/VEO monitor, IN0 EQ bypassed		1.5 UI + 220	ps
		Adapt mode 0, All supported data rates, disable HEO/VEO monitor, IN1± EQ = default		1.5 UI + 190	

(5) IN1± can also be configured to lock to SMPTE data rates via register override control. For more information, refer to the LMH1219 Programming Guide.

(6) This parameter is data rate dependent. For example, at 11.88 Gbps, 1.5 UI = 1.5 x 84.17 ps = 126.25 ps. Therefore, T_{Latency} = (126.25 + 220) ps = 346.25 ps.

LMH1219

SNLS530D – APRIL 2016 – REVISED JUNE 2018

www.ti.com

Electrical Characteristics (continued)

over operating free-air temperature range (unless otherwise noted)

PARAMETER		CONDITIONS	MIN	TYP	MAX	UNIT
T _{PD-RAW}	Propagation Delay, RAW (reclocker bypassed)	All supported data rates, IN0 EQ bypassed		300		ps
		Raw Data (reclocker bypassed), IN1± EQ = default		250		
FCLK _{OUT}	Output Clock Frequency OUT1 Programmed to Output Recovered Clock	Operating at 11.88 Gbps		297		MHz
		Operating at 5.94 Gbps		297		MHz
		Operating at 2.97 Gbps		2.97		GHz
		Operating at 1.485 Gbps		1.485		GHz
		Operating at 270 Mbps		270		MHz

6.6 Recommended SMBus Interface AC Timing Specificationsover recommended operating supply and temperature ranges (unless otherwise specified)⁽¹⁾⁽²⁾⁽³⁾

PARAMETER		TEST CONDITIONS	MIN	NOM	MAX	UNIT
F _{SCL}	SMBus SCL Frequency		10		400	kHz
T _{BUF}	Bus Free Time Between Stop and Start Condition		1.3			μs
T _{HD:STA}	Hold time after (Repeated) Start Condition. After this period, the first clock is generated.		0.6			μs
T _{SU:STA}	Repeated Start Condition Setup Time		0.6			μs
T _{SU:STO}	Stop Condition Setup Time		0.6			μs
T _{HD:DAT}	Data Hold Time		0			ns
T _{SU:DAT}	Data Setup Time		100			ns
T _{LOW}	Clock Low Period		1.3			μs
T _{HIGH}	Clock High Period		0.6			μs
T _R	Clock/Data Rise Time				300	ns
T _F	Clock/Data Fall Time				300	ns

(1) These parameters support SMBus 2.0 specifications.

(2) These parameters are not production tested.

(3) See [Figure 1](#) for timing diagrams.

6.7 Serial Parallel Interface (SPI) AC Timing Specifications

over recommended operating supply and temperature ranges (unless otherwise specified) ⁽¹⁾

PARAMETER	TEST CONDITIONS	MIN	NOM	MAX	UNIT
F _{SCK}	SPI SCK Frequency		10	20	MHz
T _{SCK}	SCK Period	50			ns
T _{PH}	SCK Pulse Width High	0.40 x T _{SCK}			ns
T _{PL}	SCK Pulse Width Low	0.40 x T _{SCK}			ns
T _{SU}	MOSI Setup Time	4			ns
T _H	MOSI Hold Time	4			ns
T _{SSSU}	SS_N Setup Time	14			ns
T _{SSH}	SS_N Hold Time	4			ns
T _{SSOF}	SS_N Off Time	1			μs
T _{ODZ}	MISO Driven-to-Tristate Time		20		ns
T _{OZD}	MISO Tristate-to-Driven Time		10		ns
T _{OD}	MISO Output Delay Time		15		ns

(1) See Figure 2 for timing diagrams.

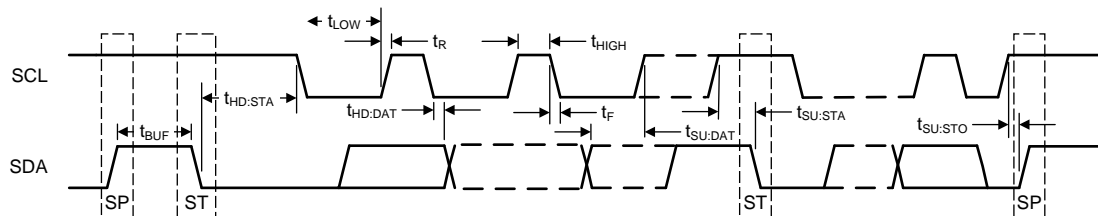

Figure 1. SMBus Timing Parameters

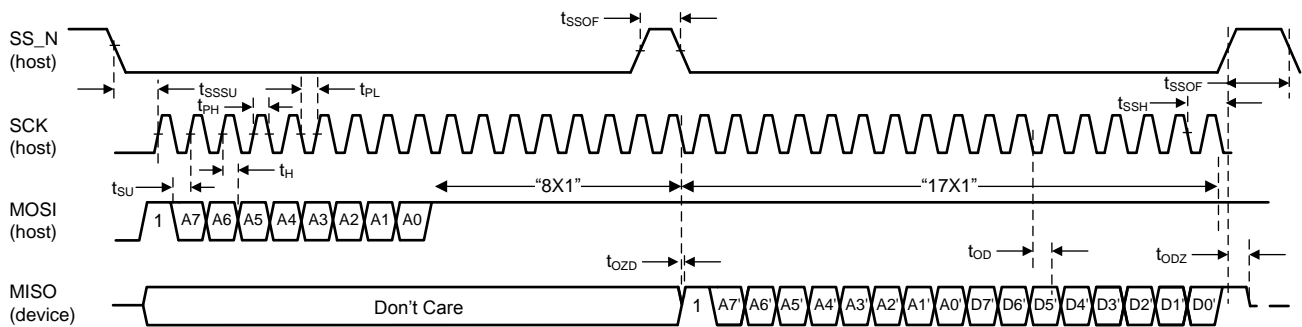
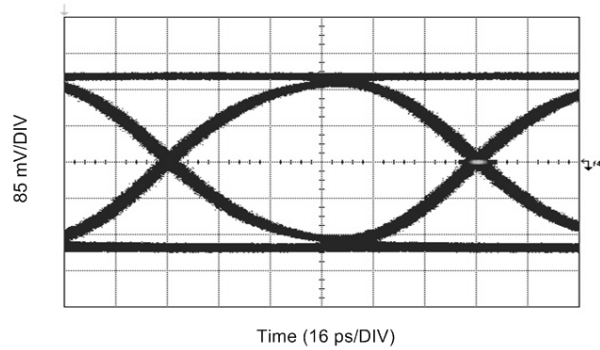
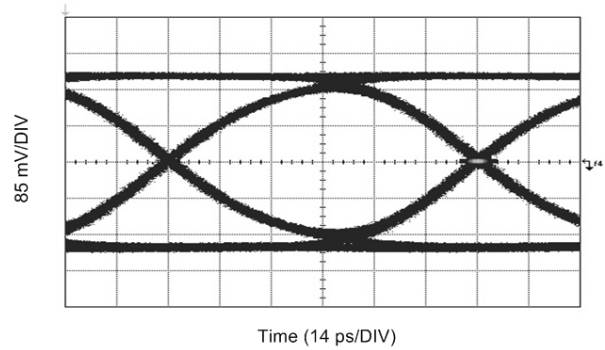
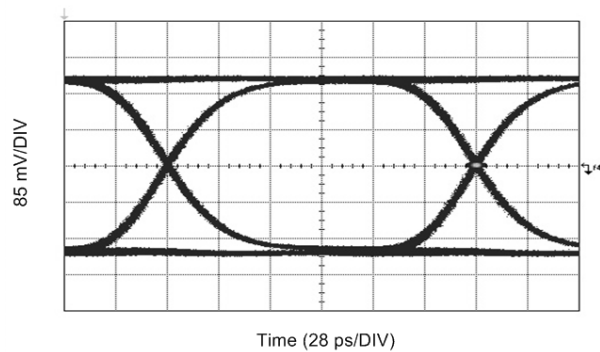
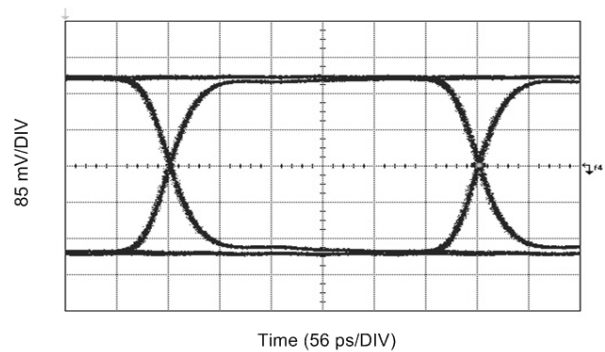
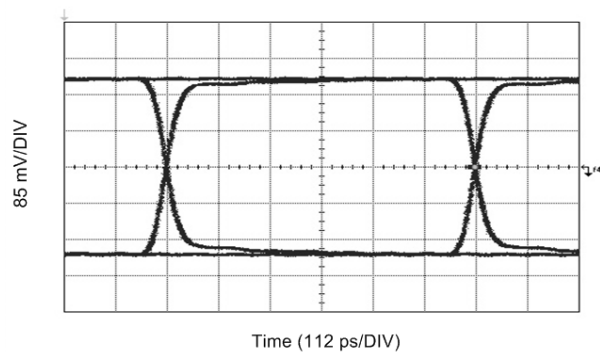
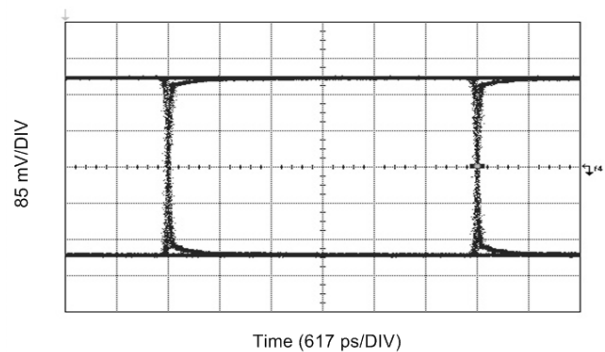

Figure 2. SPI Timing Parameters

LMH1219

SNLS530D – APRIL 2016 – REVISED JUNE 2018

www.ti.com**6.8 Typical Characteristics** $T_A = 25^\circ\text{C}$ and $V_{IN} = V_{DDIO} = V_{DD_CDR} = 2.5\text{ V}$ (unless otherwise noted)**Figure 3. 10.3125 Gbps, IN1: 20 in. FR4 Trace****Figure 4. 11.88 Gbps, IN0: 75 m Belden 1694A****Figure 5. 5.94 Gbps, IN0: 120 m Belden 1694A****Figure 6. 2.97 Gbps, IN0: 200 m Belden 1694A****Figure 7. 1.485 Gbps, IN0: 280 m Belden 1694A****Figure 8. 270 Mbps, IN0: 600 m Belden 1694A**

Typical Characteristics (continued)

$T_A = 25^\circ\text{C}$ and $V_{IN} = V_{DDIO} = V_{DD_CDR} = 2.5\text{ V}$ (unless otherwise noted)

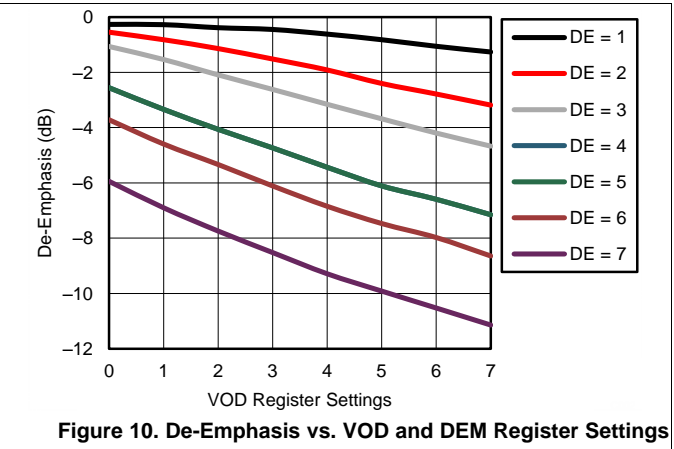
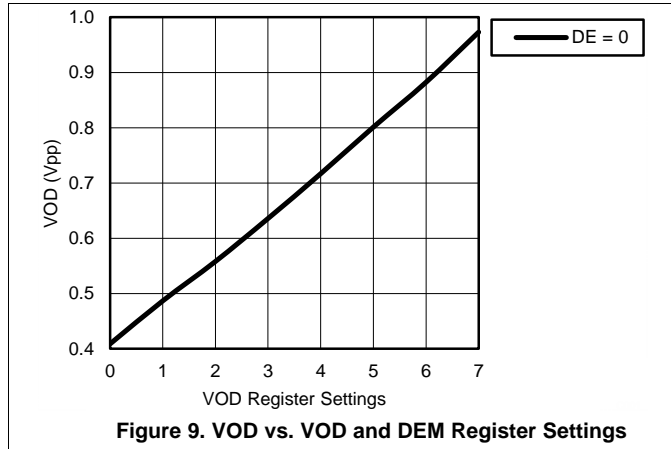

LMH1219

SNLS530D – APRIL 2016 – REVISED JUNE 2018

www.ti.com

7 Detailed Description

7.1 Overview

The LMH1219 is a SMPTE compatible, low-power UHD adaptive cable equalizer with integrated reclocker. The LMH1219 has two inputs: a 75-Ω cable equalizer and a 100-Ω PCB (printed circuit board) equalizer. The 75-Ω cable equalizer input features an internal 75-Ω termination and compensation network for meeting stringent SMPTE return loss requirements. The 100-Ω PCB equalizer input supports high speed signals across differential PCB traces that connect to an external SFF-8431 optical module or on-board FPGA. An internal 2:1 input mux allows users to select between the 75-Ω cable equalizer and the 100-Ω PCB equalizer. The selected input then passes through a multi-rate reclocker with a built-in loop-filter. The multi-rate reclocker is compatible with SMPTE data rates (11.88, 5.94, 2.97, 1.485 Gbps, 270 Mbps) and their divide-by-1.001 sub-rates. It is also compatible with the 10 GbE data rate (10.3125 Gbps). After the reclocker, an internal 1:2 fan-out mux allows users to select the data or clock content for each output. At both outputs, the LMH1219 has 100-Ω drivers with de-emphasis. The de-emphasis feature of the drivers is designed to compensate for insertion loss caused by output PCB traces.

The operating mode of the LMH1219 can be set by 4-level control pins, SPI, or SMBus serial control interface. The LMH1219 can be powered from a single 2.5 V supply or dual 2.5 V/1.8 V supplies for lower power consumption. The LMH1219 is offered in a small 4 mm x 4 mm 24-lead QFN package.

7.2 Functional Block Diagram

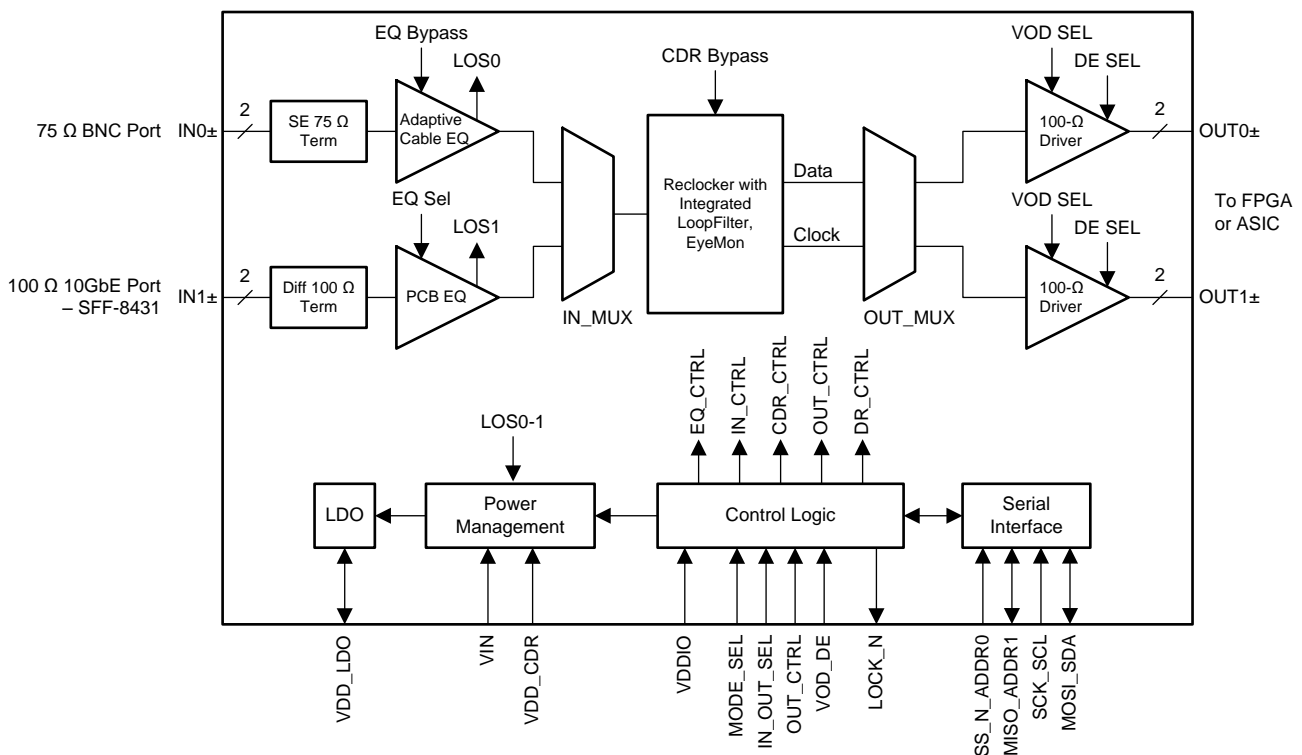

7.3 Feature Description

The LMH1219 consists of several key blocks:

- [4-Level Input Configuration Pins](#)
- [Input Carrier Detect](#)
- [-6 dB Splitter Mode Launch Amplitude for IN0](#)
- [Continuous Time Linear Equalizer \(CTLE\)](#)
- [Input-Output Mux Selection](#)
- [Clock and Data Recovery \(CDR\) Reclocker](#)
- [Internal Eye Opening Monitor \(EOM\)](#)
- [Output Function Control](#)
- [Output Driver Amplitude and De-Emphasis Control](#)
- [Status Indicators and Interrupts](#)

7.3.1 4-Level Input Configuration Pins

The 4-level input configuration pins use a resistor divider to provide four logic states for each control pin. There is an internal 30-k Ω pull-up and a 60-k Ω pull-down connected to the control pin that sets the default voltage at $2/3 \times VDDIO$. These resistors, together with the external resistor, combine to achieve the desired voltage level. By using the 1-k Ω pull-down, 20-k Ω pull-down, no connect, and 1-k Ω pull-up, the optimal voltage levels for each of the four input states are achieved as shown in [Table 1](#).

Table 1. 4-Level Control Pin Settings

LEVEL	SETTING	RESULTING PIN VOLTAGE
H	Tie 1 k Ω to VDDIO	VDDIO
F	Float (leave pin open)	$2/3 \times VDDIO$
R	Tie 20 k Ω to VSS	$1/3 \times VDDIO$
L	Tie 1 k Ω to VSS	0

Typical 4-Level Input Thresholds:

- Internal Threshold between L and R = $0.2 \times VDDIO$
- Internal Threshold between R and F = $0.5 \times VDDIO$
- Internal Threshold between F and H = $0.8 \times VDDIO$

7.3.2 Input Carrier Detect

Both inputs of the LMH1219 have a Carrier Detect circuit to monitor the presence or absence of the input signal. When the input signal amplitude for the selected input (determined by IN_OUT_SEL pin) surpasses the Carrier Detect assert threshold, the LMH1219 operates in normal mode.

In the absence of an input signal, the LMH1219 automatically goes into Power Save Mode to conserve power consumption. When a valid signal is detected, the LMH1219 automatically exits Power Save Mode and returns to the normal operating mode.

7.3.3 -6 dB Splitter Mode Launch Amplitude for IN0

The LMH1219 is designed to equalize data transmitted through a coaxial cable driven by a SMPTE compatible cable driver with launch amplitude of 800 mVp-p $\pm 10\%$. In applications where a 1:2 passive splitter is used, the signal amplitude is reduced by half due to the 6 dB insertion loss of the splitter. The LMH1219 is designed to support -6 dB splitter mode for IN0, enabled by SPI or SMBus serial interface. For more information, refer to the LMH1219 Register Map and the Programming Guide.

7.3.4 Continuous Time Linear Equalizer (CTLE)

The LMH1219 has two Continuous Time Linear Equalizer (CTLE) blocks, one for each input. The CTLE compensates for frequency-dependent loss due to the transmission media prior to the device input. The CTLE accomplishes this by applying variable gain to the input signal, thereby boosting higher frequencies more than lower frequencies.

LMH1219

SNLS530D – APRIL 2016 – REVISED JUNE 2018

www.ti.com

Only one CTLE is enabled at a time, in accordance with the input channel selected by the input mux. If IN0 is selected, the IN0 cable CTLE is powered on and the IN1 PCB CTLE is powered off. Alternatively, the two CTLEs can be bypassed either by using the OUT_CTRL pin or via register control.

7.3.4.1 Adaptive Cable Equalizer (IN0+)

If IN0 is selected, adaptive cable equalization is enabled by default. IN0 has an on-chip 75-Ω termination to the input common mode voltage and includes a series return loss compensation network for meeting stringent SMPTE return loss requirements. It is designed for AC coupling, requiring a 4.7-μF AC coupling capacitor for minimizing base-line wander due to the rare-occurring pathological bit pattern. The cable equalizer is designed with high gain and low noise circuitry to compensate for the insertion loss of a coaxial cable, such as Belden 1694A, which is widely used in broadcast video infrastructures.

Internal control loops are used to monitor the input signal quality and automatically select the optimum equalization boost and DC offset compensation. The LMH1219 is designed to handle the stringent pathological pattern defined in the SMPTE RP 198 and SMPTE RP 178 standards.

7.3.4.2 Adaptive PCB Trace Equalizer (IN1±)

The IN1 PCB equalizer has an on-chip 100-Ω termination and is designed for AC coupling, requiring a 4.7-μF AC coupling capacitor for minimizing base-line wander due to the rare-occurring pathological bit pattern. The PCB equalizer can compensate up to 20 inches of board trace at data rates up to 11.88 Gbps. There are two adapt modes for IN1: AM0 manual mode and AM1 adaptive mode. In AM0 manual mode, fixed EQ boost settings are applied through user-programmable register control, whereas in AM1 adaptive mode, state machines automatically find the optimal equalization setting from a set of 16 pre-determined settings defined in Registers 0x40-0x4F.

If IN1 is selected, AM1 adaptive mode is enabled at the 10 GbE data rate by default. The PCB equalizer is able to adapt at 10.3125 Gbps (10 GbE) and 2.97 Gbps, 5.94 Gbps, and 11.88 Gbps (SMPTE) data rates. At 1.485 Gbps and 270 Mbps data rates, the equalization is fixed at 0x00 (minimum EQ boost). This fixed EQ value can be changed via register control. For more details, refer to the LMH1219 Register Map and Programming Guide.

7.3.5 Input-Output Mux Selection

By default, the LMH1219 input-to-output signal flow and data rate selection are configured by the IN_OUT_SEL pin logic settings shown in [Table 2](#). These settings can be overridden via register control by applying the appropriate override bit values. For more information, refer to the LMH1219 Register Map and Programming Guide.

Table 2. IN_OUT_SEL Pin Settings

LEVEL	DEFINITION
H	SMPTE Data Rates: IN0 to OUT0 and OUT1
F	SMPTE Data Rates: IN0 to OUT0 (OUT1 disabled)
R	10 GbE Data Rate: IN1 to OUT1 (OUT0 disabled)
L	10 GbE Data Rate: IN1 to OUT0 and OUT1

7.3.6 Clock and Data Recovery (CDR) Reclocker

After the input signal passes through the CTLE, the equalized data is fed into the clock and data recovery (CDR) block. Using an internal PLL, the CDR locks to the incoming equalized data and recovers a clean internal clock to re-sample the equalized data. The LMH1219 CDR is able to tolerate high input jitter, tracking low frequency input jitter below the PLL bandwidth while reducing high frequency input jitter above the PLL bandwidth.

The supported data rates are listed in [Table 3](#). By default, IN0 locks to SMPTE data rates and IN1 locks to the 10 GbE data rate, according to the IN_OUT_SEL pin logic shown previously in [Table 2](#). IN1 can be programmed to lock to SMPTE data rates via register control by applying the appropriate override bit values. For more information, refer to the LMH1219 Register Map and Programming Guide.

Table 3. Supported Data Rates

INPUT	DATA RATE	RECLOCKER MODE
IN0+	11.88 Gbps, 5.94 Gbps, 2.97 Gbps, 1.485 Gbps, 270 Mbps ⁽¹⁾	Reclocker Enabled
	125 Mbps	Reclocker Disabled (CDR Bypassed)
IN1±	10.3125 Gbps	Reclocker Enabled
	1.25 Gbps	Reclocker Disabled (CDR Bypassed)

(1) Divide-by-1.001 lock rates available only for 11.88 Gbps, 5.94 Gbps, 2.97 Gbps, and 1.485 Gbps.

NOTE

If the selected data rate (SMPTE or 10 GbE) is changed while the device is operating with active data, a CDR reset and release is required for the CDR to re-acquire lock. If the input data signal is toggled off and on after the selected data rate is changed, the Carrier Detect circuit will reset the CDR. In this case, no register write is needed for the CDR to re-acquire lock.

7.3.7 Internal Eye Opening Monitor (EOM)

The LMH1219 has an on-chip eye opening monitor (EOM) that can be used to analyze, monitor, and diagnose the post-equalized waveform, just prior to the CDR reclocker. The EOM is operational for 2.97 Gbps and higher data rates.

The EOM monitors the post-equalized waveform in a time window that spans one unit interval and a configurable voltage range that spans up to ± 400 mV differential. The time window and voltage range are divided into 64 steps, so the result of the eye capture is a 64×64 matrix of *hits*, where each point represents a specific voltage and phase offset relative to the main data sampler. The number of *hits* registered at each point needs to be taken in context with the total number of bits observed at that voltage and phase offset in order to determine the corresponding probability for that point. The number of bits observed at each point is configurable.

The resulting 64×64 matrix produced by the EOM can be processed by software and visualized in a number of ways. Two common ways to visualize this data are shown in [Figure 11](#) and [Figure 12](#). These diagrams depict examples of eye monitor plots implemented by software. The first plot is an example using the EOM data to plot a basic eye using ASCII characters, which can be useful for simple diagnostic software. The second plot shows the first derivative of the EOM data, revealing the density of hits and the actual waveforms and crossings that comprise the eye.

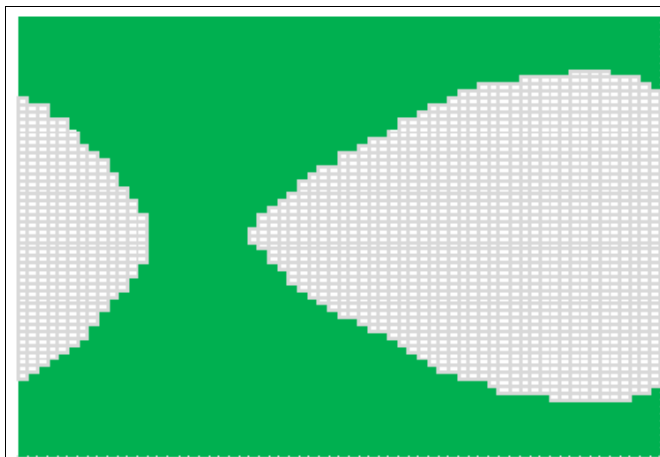

Figure 11. Internal Input Eye Monitor Plot

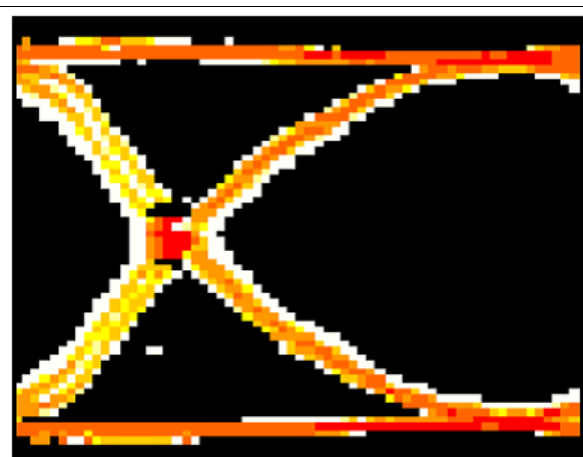

Figure 12. Internal Eye Monitor Hit Density Plot

LMH1219

SNLS530D – APRIL 2016 – REVISED JUNE 2018

www.ti.com

A common measurement performed by the EOM is the horizontal and vertical eye opening. The horizontal eye opening (HEO) represents the width of the post-equalized eye at 0-V differential amplitude, measured in unit intervals or picoseconds (ps). The vertical eye opening (VEO) represents the height of the post-equalized eye, measured midway between the mean zero crossing of the eye. This position in time approximates the CDR sampling phase.

7.3.8 Output Function Control

By default, the LMH1219 output function control for OUT0 and OUT1 is configured by the OUT_CTRL pin logic settings shown in [Table 4](#). These settings can be overridden via register control by applying the appropriate override bit values. For more information, refer to the LMH1219 Register Map and Programming Guide.

Table 4. OUT_CTRL Pin Settings

LEVEL	DEFINITION
H	OUT0 and OUT1: Raw Data, Both EQ and Reclocker Bypassed
F	OUT0 and OUT1: Recovered Data, Both EQ and Reclocker Enabled
R	OUT0: Recovered Data, EQ and Reclocker Enabled OUT1: Full-Rate Recovered Clock if Data Rate ≤ 3 Gbps. 297 MHz Recovered Clock if Data Rate > 3 Gbps ⁽¹⁾
L	OUT0 and OUT1: Equalized Data, EQ Enabled, Reclocker Bypassed

(1) This setting is only valid for SMPTE data rates. It is not supported for the 10 GbE data rate.

7.3.9 Output Driver Amplitude and De-Emphasis Control

The VOD_DE control pin selects the output amplitude and de-emphasis settings for both OUT0 and OUT1. It offers users the capability to select higher output amplitude and de-emphasis levels for longer board trace that connects the drivers to their downstream receivers. Driver de-emphasis provides transmitter equalization to reduce the ISI caused by the board trace.

By default, the output driver VOD and de-emphasis settings are configured by the VOD_DE pin logic settings shown in [Table 5](#). These settings can be overridden via register control by applying the appropriate override bit values. When these parameters are controlled by registers, the VOD and de-emphasis levels for each channel can be programmed independently. For more information, refer to the LMH1219 Register Map and the Programming Guide.

Table 5. Recommended VOD_DE Pin and Register Settings for Different FR4 Trace Lengths⁽¹⁾

VOD_DE LEVEL	VOD REG SETTING OUT0±: 0x30[5]=1, 0x30[2:0] OUT1±: 0x32[5]=1, 0x32[2:0]	DEM REG SETTING OUT0±: 0x31[6]=1, 0x31[2:0] OUT1±: 0x33[6]=1, 0x33[2:0]	VOD (mVpp) ⁽²⁾	VOD _{DE} (mVpp) ⁽²⁾	DEM (dB)	FR4 TRACE LENGTH (inches)
H	0	0	410	410	0	0 – 1
F	2	2	560	500	-0.9	2 – 4
R	3	3	635	480	-2.4	5 – 6
L	5	5	810	480	-6.1	7 – 8

(1) The output drivers are capable of providing higher VOD and DEM levels (max settings are 7). For more VOD and de-emphasis levels, refer to [Table 10](#).

(2) See [Figure 13](#).

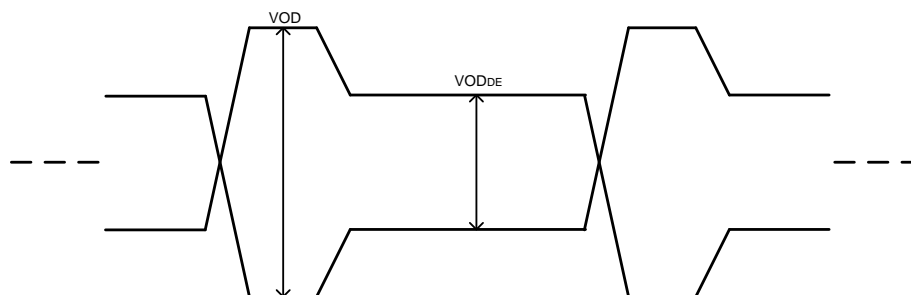
**Figure 13. VOD and VOD_{DE} Levels**

7.3.10 Status Indicators and Interrupts

7.3.10.1 LOCK_N (Lock Indicator)

The LOCK_N pin is a 3.3 V tolerant, active-low open drain output. An external resistor to the logic supply is required. By default, LOCK_N is the reclocker lock indicator, and this pin asserts low when the LMH1219 achieves lock to a valid SMPTE or 10 GbE data rate. The LOCK_N pin functionality can also be configured via register control to indicate CD_N (Carrier Detect) or INT_N (Interrupt) events. For more information about how to reconfigure the LOCK_N pin functionality, refer to the LMH1219 Register Map and the Programming Guide.

7.3.10.2 CD_N (Carrier Detect)

The LOCK_N pin can be reconfigured via register control to indicate a CD_N (Carrier Detect) event. When configured as a CD_N output, the pin asserts low at the end of adaptation after a valid signal is detected by the Carrier Detect circuit of the selected input. Under register control, this pin can be reconfigured to indicate CD_N for IN0 or IN1. For more information about how to configure the LOCK_N pin for CD_N functionality, refer to the LMH1219 Register Map and the Programming Guide.

7.3.10.3 INT_N (Interrupt)

The LOCK_N pin can be configured to indicate an INT_N (Interrupt) event. When configured as an INT_N output, the pin asserts low when an interrupt occurs, according to the programmed interrupt masks. Seven separate masks can be programmed via register control as interrupt sources:

- If there is a Loss of Signal (LOS) event on IN0, irrespective of the input channel selected (2 separate masks).
- If there is a Loss of Signal (LOS) event on IN1, irrespective of the input channel selected (2 separate masks).
- If HEO or VEO falls below a certain threshold after CDR is locked (1 mask).
- If a CDR Lock event has occurred (2 separate masks).

INT_N is a sticky bit, meaning that it will flag after an interrupt occurs and will not clear until read back. Once the Interrupt Status Register is read, the INT_N pin will assert high again. For more information about how to configure the LOCK_N pin for INT_N functionality, refer to the LMH1219 Register Map and the Programming Guide.

7.3.11 Additional Programmability

The LMH1219 supports extended programmability through the use of an SPI or SMBus serial control interface. Such added programmability includes:

- Cable Length Indicator (CLI)
- Digital MUTE_{REF}

7.3.11.1 Cable Length Indicator (CLI)

The Cable Length Indicator (CLI) indicates the length of the coax cable attached to IN0+. CLI is accessible through CableEQ/Driver Page Reg 0x25[5:0]. The 6-bit setting ranges in decimal value from 0 to 55 (000000'b to 110111'b in binary), corresponding to approximately 0 to 600 m of Belden 1694A cable.

7.3.11.2 Digital MUTE_{REF}

Digital MUTE_{REF} CableEQ/Driver Page Reg 0x03[5:0] sets the threshold for the maximum cable length at IN0+ to be equalized before muting the outputs. The MUTE_{REF} register value is directly proportional to the cable length being equalized. MUTE_{REF} is data rate dependent. Follow the steps below to set the MUTE_{REF} register setting for any desired SDI rate:

1. Connect the desired input cable length at which the driver output needs to be muted.
2. Send video patterns to IN0+ at the SD rate (270 Mbps). At SD, the Cable Length Indicator (CLI) has the largest dynamic range.
3. Read back Cable EQ/Driver Page Reg 0x25[5:0] to record the CLI value.
4. Copy the CLI value, and write this value to Digital MUTE_{REF} Cable EQ/Driver Page Reg 0x03[5:0].

LMH1219

SNLS530D – APRIL 2016 – REVISED JUNE 2018

www.ti.com

7.4 Device Functional Modes

The LMH1219 operates in one of two modes: System Management Bus (SMBus) or Serial Peripheral Interface (SPI) mode. In order to determine the mode of operation, the proper setting must be applied to the MODE_SEL pin at power-up, as detailed in [Table 6](#).

Table 6. MODE_SEL Pin Settings

LEVEL	DEFINITION
H	Forced Power Save Mode, only SPI is enabled (all other circuitry powered down)
F	Select SPI Interface for register access
R	Reserved for factory testing – do not use
L	Select SMBus Interface for register access

NOTE

Changing logic states between LEVEL-L and LEVEL-H after power up is not allowed.

7.4.1 System Management Bus (SMBus) Mode

If MODE_SEL = L, the LMH1219 is in SMBus mode. In SMBus mode, Pins 10 and 21 are configured as SDA and SCL. Pins 7 and 20 act as 4-level address straps for ADDR0 and ADDR1 at power up to determine the 7-bit slave address of the LMH1219, as shown in [Table 7](#).

Table 7. SMBus Device Slave Addresses⁽¹⁾

ADDR0 (LEVEL)	ADDR1 (LEVEL)	7-BIT SLAVE ADDRESS [HEX]	8-BIT WRITE COMMAND [HEX]
L	L	1D	3A
L	R	1E	3C
L	F	1F	3E
L	H	20	40
R	L	21	42
R	R	22	44
R	F	23	46
R	H	24	48
F	L	25	4A
F	R	26	4C
F	F	27	4E
F	H	28	50
H	L	29	52
H	R	2A	54
H	F	2B	56
H	H	2C	58

- (1) The 8-bit write command consists of the 7-bit slave address (Bits 7:1) with 0 appended to the LSB to indicate an SMBus write. For example, if the 7-bit slave address is 0x1D (001 1101'b), the 8-bit write command is 0x3A (0011 1010'b).

7.4.1.1 SMBus Read and Write Transactions

SMBus is a two-wire serial interface through which various system component chips can communicate with the master. Slave devices are identified by having a unique device address. The two-wire serial interface consists of SCL and SDA signals. SCL is a clock output from the master to all of the slave devices on the bus. SDA is a bidirectional data signal between the master and slave devices. The LMH1219 SMBus SCL and SDA signals are open drain and require external pull-up resistors.

Start and Stop:

The master generates start and stop patterns at the beginning and end of each transaction.

- Start: High to low transition (falling edge) of SDA while SCL is high.
- Stop: Low to high transition (rising edge) of SDA while SCL is high.

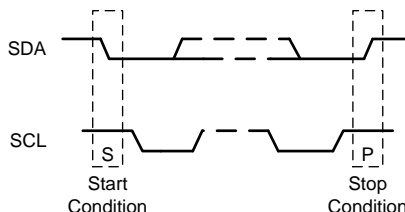

Figure 14. Start and Stop Conditions

The master generates nine clock pulses for each byte transfer. The 9th clock pulse constitutes the ACK cycle. The transmitter releases SDA to allow the receiver to send the ACK signal. An ACK is recorded when the device pulls SDA low, while a NACK is recorded if the line remains high.

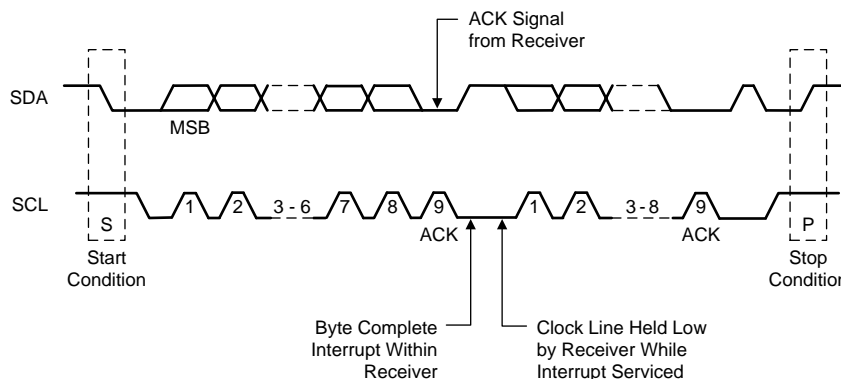

Figure 15. Acknowledge (ACK)

7.4.1.1.1 SMBus Write Operation Format

Writing data to a slave device consists of three parts, as illustrated in Figure 16:

1. The master begins with a start condition, followed by the slave device address with the R/\overline{W} bit set to 0'b.
2. After an ACK from the slave device, the 8-bit register word address is written.
3. After an ACK from the slave device, the 8-bit data is written, followed by a stop condition.

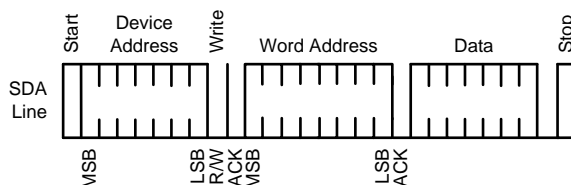

Figure 16. SMBus Write Operation

LMH1219

SNLS530D – APRIL 2016 – REVISED JUNE 2018

www.ti.com

7.4.1.1.2 SMBus Read Operation Format

Reading data from a slave device consists of four parts, as illustrated in Figure 17:

1. The master begins with a start condition, followed by the slave device address with the $\overline{R/\overline{W}}$ bit set to 0'b.
2. After an ACK from the slave device, the 8-bit register word address is written.
3. After an ACK from the slave device, the master initiates a re-start condition, followed by the slave address with the $\overline{R/\overline{W}}$ bit set to 1'b.
4. After an ACK from the slave device, the 8-bit data is read back. The last ACK is high if there are no more bytes to read, and the last read is followed by a stop condition.

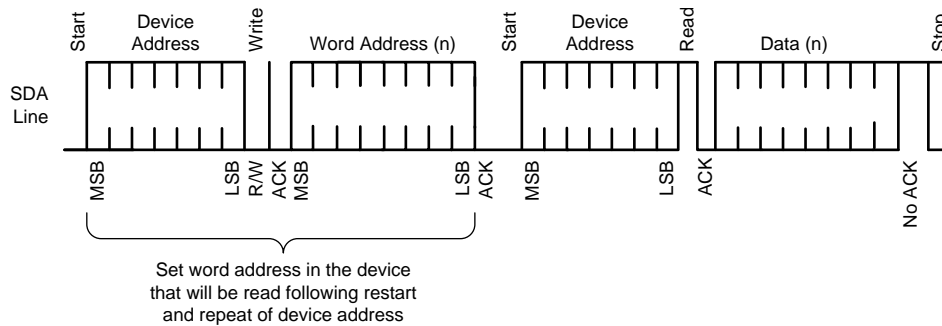
**Figure 17. SMBus Read Operation****7.4.2 Serial Peripheral Interface (SPI) Mode**

If $\text{MODE_SEL} = \text{F}$ or H , the LMH1219 is in SPI mode. In SPI mode, the following pins are used for SPI bus communication:

- MOSI (pin 10): Master Output Slave Input
- MISO (pin 20): Master Input Slave Output
- SS_N (pin 7): Slave Select (active low)
- SCK (pin 21): Serial clock (input to the LMH1219 slave device)

7.4.2.1 SPI Read and Write Transactions

Each SPI transaction to a single device is 17 bits long and is framed by SS_N when asserted low. The MOSI input is ignored, and the MISO output is floated whenever SS_N is de-asserted (high).

The bits are shifted in left-to-right. The first bit is $\overline{R/\overline{W}}$, which is 1'b for "read" and 0'b for "write." Bits A7-A0 are the 8-bit register address, and bits D7-D0 are the 8-bit read or write data. The previous SPI command, address, and data are shifted out on MISO as the current command, address, and data are shifted in on MOSI. In all SPI transactions, the MISO output signal is enabled asynchronously when SS_N asserts low. The contents of a single MOSI or MISO transaction frame are shown in Table 8.

Table 8. 17-Bit Single SPI Transaction Frame

$\overline{R/\overline{W}}$	A7	A6	A5	A4	A3	A2	A1	A0	D7	D6	D5	D4	D3	D2	D1	D0
-----------------------------	----	----	----	----	----	----	----	----	----	----	----	----	----	----	----	----

7.4.2.1.1 SPI Write Transaction Format

For SPI writes, the $\overline{R/\overline{W}}$ bit is 0'b. SPI write transactions are 17 bits per device, and the command is executed on the rising edge of SS_N . The SPI transaction always starts on the rising edge of the clock.

The signal timing for a SPI Write transaction is shown in Figure 18. The "prime" values on MISO (for example, A7') reflect the contents of the shift register from the previous SPI transaction and are *don't-care* for the current transaction.

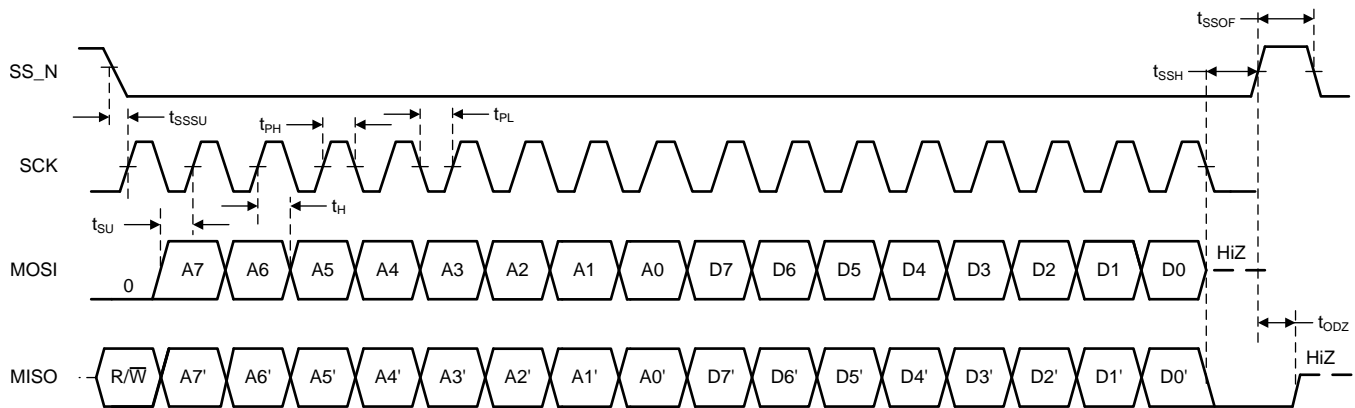

Figure 18. Signal Timing for a SPI Write Transaction

7.4.2.1.2 SPI Read Transaction Format

A SPI read transaction is 34 bits per device and consists of two 17-bit frames. The first 17-bit read transaction frame shifts in the address to be read, followed by a dummy transaction second frame to shift out 17-bit read data. The $\overline{R/\overline{W}}$ bit is 1'b for the read transaction, as shown in Figure 19.

The first 17 bits from the read transaction specifies 1-bit of $\overline{R/\overline{W}}$ and 8-bits of address A7-A0 in the first 8 bits. The eight 1's following the address are ignored. The second dummy transaction acts like a read operation on address 0xFF and needs to be ignored. However, the transaction is necessary in order to shift out the read data D7-D0 in the last 8 bits of the MISO output. As with the SPI Write, the “prime” values on MISO during the first 16 clocks are *don't-care* for this portion of the transaction. The values shifted out on MISO during the last 17 clocks reflect the read address and 8-bit read data for the current transaction.

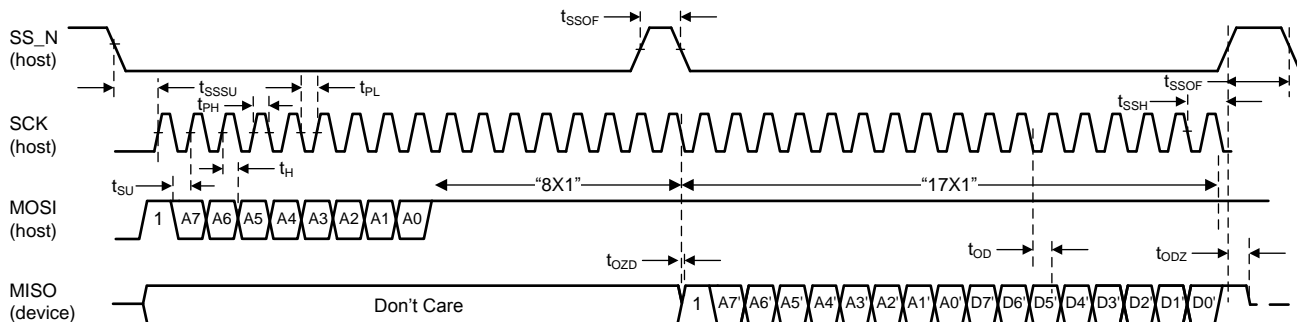

Figure 19. Signal Timing for a SPI Read Transaction

LMH1219

SNLS530D – APRIL 2016 – REVISED JUNE 2018

www.ti.com**7.4.2.2 SPI Daisy Chain**

The LMH1219 supports SPI daisy-chaining among multiple devices, as shown in [Figure 20](#).

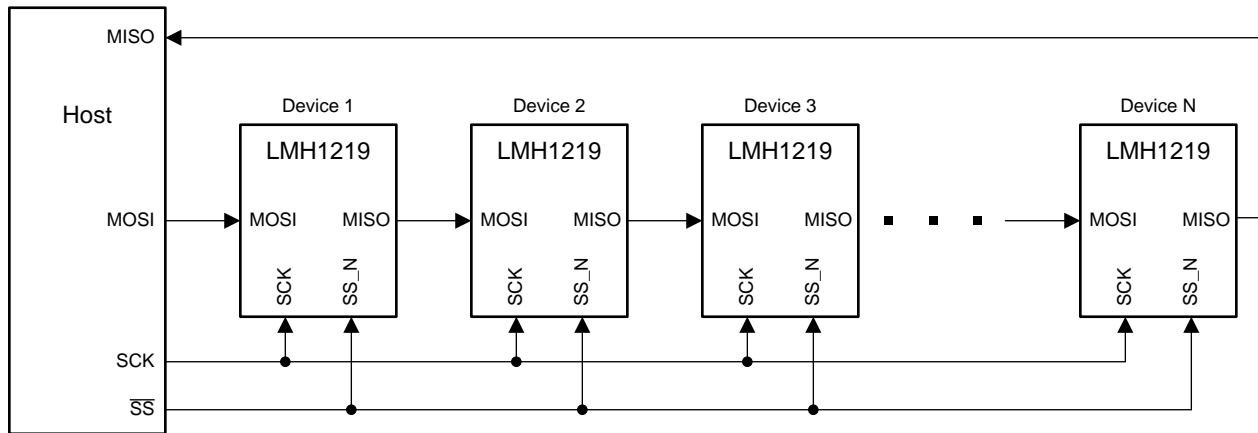

Figure 20. Daisy-Chain Configuration

Each LMH1219 device is directly connected to the SCK and SS_N pins of the host. The first LMH1219 device in the chain is connected to the host's MOSI pin, and the last device in the chain is connected to the host's MISO pin. The MOSI pin of each intermediate LMH1219 device in the chain is connected to the MISO pin of the previous LMH1219 device, thereby creating a serial shift register. In a daisy-chain configuration of N x LMH1219 devices, the host conceptually sees a shift register of length 17 x N for a basic SPI transaction, during which SS_N is asserted low for 17 x N clock cycles.

7.5 LMH1219 Register Map

The LMH1219 register map is divided into three register pages. These register pages are used to control different aspects of the LMH1219 functionality. A brief summary of the pages is shown below:

1. **Share Register Page:** This page corresponds to global parameters, such as LMH1219 device ID and LOCK_N status configuration. This is the default page at start-up.
2. **CTLE/CDR Register Page:** This page corresponds to IN1 PCB CTLE, input and output mux settings, CDR settings, and output interrupt overrides. Access this page by setting Reg 0xFF[2:0] = 100'b.
3. **CableEQ/Drivers Register Page:** This page corresponds to IN0 Cable EQ and both OUT0 and OUT1 driver output settings. Access this page by setting Reg 0xFF[2:0] = 101'b.

For typical device configurations and proper register reset sequencing, reference the appropriate sections of the LMH1219 Programming Guide.

Please note the following about the LMH1219 default register values in the register map:

- Default register values were read after power-up with no active inputs applied to IN0 or IN1.
- Default register values for Reserved "Read-Only" bits may vary dynamically from part to part.

7.5.1 Share Register Page

Address	Register Name	Bit	Field	Default	Type	Description
0x00	Reserved	7:0	Reserved	0x00	R	Reserved
0x01	Reserved	7:0	Reserved	0x40	R	Reserved
0x02	Reserved	7:0	Reserved	0x02	RW	Reserved
0x03	Reserved	7:0	Reserved	0x00	RW	Reserved
0x04	Reserved	7:0	Reserved	0x01	RW	Reserved
0x05	Reserved	7:0	Reserved	0x00	RW	Reserved
0x06	Reserved	7:0	Reserved	0x00	RW	Reserved
0x07	Reserved	7:0	Reserved	0x04	RW	Reserved
0x08	Reserved	7:0	Reserved	0x11	RW	Reserved
0x09	Reserved	7:0	Reserved	0x00	R	Reserved
0xE2	Reset Share/Channel Regs	7:5	Reserved	0x10	R	Reserved
		4	reset_done		R	0 = Internal state machine register initialization not done. 1 = Internal state machine register initialization done.
		3:1	Reserved		RW	Reserved
		0	reset_init		RW	1 = Initialize internal state machine register settings. Refer to the LMH1219 Programming Guide for details.
0xF0	Device Revision	7:0	Version	0x02	R	Device Revision
0xF1	Device ID	7:0	Device_ID	0x80	R	For LMH1219, Device ID = 0x80

LMH1219

SNLS530D – APRIL 2016 – REVISED JUNE 2018

www.ti.com

Address	Register Name	Bit	Field	Default	Type	Description
0xFF	Register Communication Control	7:6	lock_output_ctrl	0x00	RW	Controls the output on LOCK pin if Reg 0xFF[5:4] = 01'b 00 = Lock status from Reclocker 01 = CableEQ/Driver Reg 0x00[7] status output 10 = Logical OR of LOCK status from Reclocker and CableEQ/Driver Reg 0x00[7] status 11 = Logical AND of LOCK status from Reclocker and CableEQ/Driver Reg 0x00[7] status
		5:4	los_int_bus_sel		RW	Controls the output on LOCK_N pin 00 = Default behavior (LOCK_N outputs lock status from reclocker) 01 = LOCK_N pin output status determined by Reg 0xFF[7:6] 10 = LOS of selected input (IN0 or IN1) 11 = Interrupts are output on LOCK_N pin, as determined by CTLE/CDR Page Reg 0x56[6:0]
		3	Reserved		RW	Reserved
		2	page_select_enable		RW	0 = The shared registers are enabled. 1 = Enables communication access to the Register Page specified in Reg 0xFF[1:0].
		1:0	page_select		RW	Enable communication access to a specific Register Page 00 = CTLE/CDR Register Page 01 = CableEQ/Drivers Register Page Other values are invalid.

7.5.2 CTLE/CDR Register Page

Address	Register Name	Bit	Field	Default	Type	Description
0x00	Reset CTLE/CDR Registers	7:3	Reserved	0x00	RW	Reserved
		2	rst_CTLE/CDR_regs		RW	Reset registers (self-clearing) 0 = Normal Operation 1 = Reset CTLE/CDR Registers. Register re-initialization procedure required after resetting the CTLE/CDR Registers.
		1:0	Reserved		RW	Reserved
0x01	LOS Status	7:2	Reserved	0x03	RW	Reserved
		1	LOS1		R	0 = Signal Present on IN1 1 = Loss of Signal on IN1
		0	Reserved		R	Reserved
0x02	CDR_Status	7:0	CDR_Status	0x41	R	CDR status indicator. See "Lock Data Rate Indication" subsection in the LMH1219 Programming Guide for more information.
0x03	IN1 Manual EQ Boost	7:6	eq_BST0	0x80	RW	Used for setting manual EQ value for IN1 when Reg 0x2D[3] = 1. EQ boost value can be read back on CTLE/CDR Page Reg 0x52. [7:6]: 2-bit control for Stage 0 of the CTLE. [5:4]: 2-bit control for Stage 1 of the CTLE. [3:2]: 2-bit control for Stage 2 of the CTLE. [1:0]: 2-bit control for Stage 3 of the CTLE.
		5:4	eq_BST1		RW	
		3:2	eq_BST2		RW	
		1:0	eq_BST3		RW	
0x04	Reserved	7:0	Reserved	0x00	RW	Reserved
0x05	Reserved	7:0	Reserved	0x00	RW	Reserved
0x06	Reserved	7:0	Reserved	0x00	RW	Reserved
0x07	Reserved	7:0	Reserved	0x00	RW	Reserved
0x08	Reserved	7:0	Reserved	0x00	RW	Reserved
0x09	Output Mux Override Control	7:6	Reserved	0x00	RW	Reserved
		5	reg_out_control_ov		RW	Output Mux Override Control 0 = Reg 0x1C[3:2] determines the output selection for both OUT0 and OUT1 1 = Enable individual output mux control based on values from Reg 0x1C[7:5] and Reg 0x1E[7:5]
		4:3	Reserved		RW	Reserved
		2:0	Reserved		RW	Reserved

Address	Register Name	Bit	Field	Default	Type	Description
0x0A	CDR Reset Control	7:4	Reserved	0x50	RW	Reserved
		3	reg_cdr_reset_ov		RW	0 = Disables CDR Reset (Normal Operating Mode) 1 = Enables Reg 0x0A[2] to control CDR Reset
		2	reg_cdr_reset		RW	0 = No CDR Reset if Reg 0x0A[3] = 1 1 = CDR Reset if Reg 0x0A[3] = 1
		1:0	Reserved		RW	Reserved
0x0B	Reserved	7:0	Reserved	0x1F	RW	Reserved
0x0C	CDR Output Status Control	7:4	reg_sh_status_control	0x08	RW	Value determines what CDR status outputs are displayed in CTLE/CDR Page Reg 0x02. See "Lock Data Rate Indication" subsection in the LMH1219 Programming Guide for more information.
		3:0	Reserved		RW	Reserved
0x0D	Reserved	7:0	Reserved	0x00	RW	Reserved
0x0E	Reserved	7:0	Reserved	0x93	RW	Reserved
0x0F	Reserved	7:0	Reserved	0x69	RW	Reserved
0x10	Reserved	7:0	Reserved	0x27	RW	Reserved
0x11	EOM Voltage Range Control	7:6	eom_sel_vrange	0xE0	RW	Sets the expected incoming eye diagram vertical eye opening interval if Reg 0x2C[6] = 0 00 = 3.125 mV (3.125 mV x 64 = 200 mV; ±100 mV range) 01 = 6.25 mV (6.25 mV x 64 = 400 mV; ±200 mV range) 10 = 9.375 mV (9.375 mV x 64 = 600 mV; ±300 mV range) 11 = 12.5 mV (12.5 mV x 64 = 800 mV; ±400 mV range)
		5	eom_PD		RW	0 = EOM is always powered up 1 = Power down EOM when not in use
		4:0	Reserved		RW	Reserved
0x12	Reserved	7:0	Reserved	0xA0	RW	Reserved
0x13	IN1 CTLE Control	7:4	Reserved	0x90	RW	Reserved
		3	eq_PD_EQ		RW	IN1 CTLE Power-Down Control 0 = Powers up EQ of IN1 1 = Powers down EQ of IN1 Note: The un-selected channel is always powered-down.
		2	Reserved		RW	Reserved
		1	eq_en_bypass		RW	0 = Enable Gain Stages 2 and 3 of IN1 CTLE 1 = Bypass Gain Stages 2 and 3 of IN1 CTLE
		0	Reserved		RW	Reserved
0x14	Reserved	7:0	Reserved	0x00	RW	Reserved
0x15	IN1 Carrier Detect Control and Threshold Setting	7	Reserved	0x00	RW	Reserved
		6	cd_1_PD		RW	IN1 Carrier Detect Power Down Control 0 = Power Up IN1 Carrier Detect 1 = Power Down IN1 Carrier Detect
		5:4	cd_1_refa_sel		RW	Controls IN1 Carrier Detect Assert and De-Assert Thresholds 0000 = Default levels (nominal) 0101 = Nominal - 2 mV 1010 = Nominal + 5 mV 1111 = Nominal + 3 mV
		3:2	cd_1_refd_sel		RW	
		1:0	Reserved		RW	Reserved
0x16	Reserved	7:0	Reserved	0x25	RW	Reserved
0x17	Reserved	7:0	Reserved	0x25	RW	Reserved
0x18	Reserved	7:0	Reserved	0x40	RW	Reserved
0x19	Reserved	7:0	Reserved	0x00	RW	Reserved
0x1A	Reserved	7:0	Reserved	0xA0	RW	Reserved
0x1B	Reserved	7:0	Reserved	0x03	RW	Reserved

LMH1219

SNLS530D – APRIL 2016 – REVISED JUNE 2018

www.ti.com

Address	Register Name	Bit	Field	Default	Type	Description
0x1C	OUT Mux Select_0	7:5	out_sel0_data_mux	0x58	RW	In normal operating mode, Reg 0x1C[7:5] returns the mux select value applied at OUT0. When Reg 0x09[5] = 1, OUT0 mux selection is controlled by Reg 0x1C[7:5] as follows: 000 = Mute 001 = 10 MHz Clock 010 = Raw Data (EQ Only) 100 = Retimed Data Other Settings are invalid.
		4	VCO_Div40		RW	When Reg 0x09[5] = 1 and Reg 0x1E[7:5] = 101'b, OUT1 clock selection can be controlled by Reg 0x1C[4] as follows: 0 = OUT1 outputs 10 MHz clock 1 = OUT1 outputs VCO divide-by-40
		3:2	drv_out_ctrl		RW	Controls output mux selection for both OUT0 and OUT1 if Reg 0x3F[3] = 1 to override the OUT_CTRL pin 00 = Mute both OUT0 and OUT1 01 = When CDR is locked, output reclocked data on OUT0 and output clock on OUT1. If locked data rate is ≤ 3G, OUT1 = VCO. If locked data rate is > 3G, OUT1 = VCO/40. When unlocked, output raw data on OUT0 and mute OUT1. 10 = When locked, output retimed data on both OUT0 and OUT1. When unlocked, output raw data on both OUT0 and OUT1. This is the default setting. 11 = Output raw data on both OUT0 and OUT1.
		1:0	Reserved		RW	Reserved
0x1D	Reserved	7:0	Reserved	0x00	RW	Reserved
0x1E	OUT Mux Select_1	7:5	out_sel1_data_mux	0x09	RW	In normal operating mode, Reg 0x1E[7:5] returns the mux select value applied at OUT1. When Reg 0x09[5] = 1, OUT1 mux selection is controlled by Reg 0x1E[7:5] as follows: 000 = Raw Data (EQ Only) 001 = Retimed Data 010 = Full Rate VCO clock 101 = 10 MHz Clock if Reg 0x1C[4] = 0 and VCO/40 clock if Reg 0x1C[4] = 1 111 = Mute Other Settings are invalid
		4:0	Reserved		RW	Reserved
0x1F	OUT1 Polarity	7	sel_inv_out1	0x10	RW	0 = OUT1 normal polarity 1 = Inverts OUT1 driver polarity Note: No polarity inversion for OUT0
		6:0	Reserved		RW	Reserved
0x20	Reserved	7:0	Reserved	0x00	RW	Reserved
0x21	Reserved	7:0	Reserved	0x00	RW	Reserved
0x22	Reserved	7:0	Reserved	0x00	RW	Reserved
0x23	HEO_VEO_OV	7	eom_get_heo_veo_ov	0x40	RW	0 = Disable HEO/VEO Acquisition override. 1 = Enable HEO/VEO Acquisition override. Value determined by Reg 0x24[1].
		6:0	Reserved		RW	Reserved
0x24	EOM Control	7	fast_eom	0x40	RW	0 = Disable Fast EOM mode 1 = Enable Fast EOM mode
		6	Reserved		R	Reserved
		5	get_heo_veo_error_no_hits		R	Zero Crossing Error Detector Status 0 = Zero crossing errors in the eye diagram observed 1 = No zero crossing errors in the eye diagram observed
		4	get_heo_veo_error_no_opening		R	Vertical Eye Closure Detector Status 0 = Open eye diagram detected 1 = Eye diagram completely closed
		3:2	Reserved		R	Reserved
		1	eom_get_heo_veo		RW	1 = Acquire HEO and VEO (self-clearing) if Reg 0x23[7] = 1
		0	eom_start		RW	1 = Start EOM counter (self-clearing)

Address	Register Name	Bit	Field	Default	Type	Description
0x25	EOM_MSB	7:0	eom_count_msb	0x00	R	MSBs of EOM counter
0x26	EOM_LSB	7:0	eom_count_lsb	0x00	R	LSBs of EOM counter
0x27	HEO	7:0	heo	0x00	R	HEO value. This is measured in 0-63 phase settings. To get HEO in UI, read HEO, convert hex to dec, then divide by 64.
0x28	VEO	7:0	veo	0x00	R	VEO value. This is measured in 0-63 vertical steps. To get VEO in mV, convert hex to dec, then multiply by the EOM Voltage Range defined in Reg 0x29[6:5].
0x29	Auto EOM Voltage Range	7	Reserved	0x00	RW	Reserved
		6:5	eom_vrange_setting		R	Readback of automatic EOM Voltage Range granularity. 00 = 3.125 mV 01 = 6.25 mV 10 = 9.375 mV 11 = 12.5 mV
		4:0	Reserved		RW	Reserved
0x2A	EOM_timer_thr	7:0	eom_timer_thr	0x30	RW	EOM timer for how long to check each phase/voltage setting.
0x2B	Reserved	7:0	Reserved	0x00	RW	Reserved
0x2C	VEO Scale	7	Reserved	0x72	RW	Reserved
		6	veo_scale		RW	0 = VEO scaling based on manual Voltage Range settings (see Reg 0x11[7:6]) 1 = Enable Auto VEO scaling
		5:0	Reserved		RW	Reserved
0x2D	CTLE Boost Override	7:4	Reserved	0x00	RW	Reserved
		3	reg_eq_bst_ov		RW	IN1 EQ Boost Override Control 0 = Disable IN1 EQ boost override 1 = Override the internal IN1 EQ boost settings with values in Reg 0x03[7:0]
		2:0	Reserved		RW	Reserved
0x2E	Reserved	7:0	Reserved	0x24	RW	Reserved
0x2F	Rate Overrides	7:6	refn_rate	0x06	RW	Reference Rate Selection for CDR Lock if Reg 0x3F[2] = 1 00 = Select SMPTE rates 01 = Select 10G Ethernet rate Other settings are Invalid
		5:0	Reserved		R	Reserved
0x30	Reserved	7:0	Reserved	0x00	RW	Reserved
0x31	IN1 Adaptation Mode and Input Mux Select	7	Reserved	0x00	RW	Reserved
		6:5	adapt_mode		RW	Adapt Mode Override Value if Reg 0x3F[5] = 1 00 = Manual CTLE for IN1. Set CTLE/CDR Page Reg 0x2D[3] = 1 to enable IN1 EQ boost settings with values in Reg 0x03[7:0]. 01 = Automatic CTLE Adaptation for IN1.
		4:2	Reserved		RW	Reserved
		1:0	input_mux_ch_sel		RW	Input Mux Selection if Reg 0x3F[4] = 1 to override IN_OUT_SEL pin 00 = IN0 to OUT0 and OUT1 01 = IN0 to OUT0 only 10 = IN1 to OUT1 only 11 = IN1 to OUT0 and OUT1
0x32	HEO/VEO Interrupt Threshold	7:4	heo_int_thresh	0x11	RW	Compares HEO value, Reg 0x27[7:0] vs. threshold from Reg 0x32[7:4] x 4.
		3:0	veo_int_thresh		RW	Compares VEO value. Reg 0x28[7:0] vs. threshold from Reg 0x32[3:0] x 4.
0x33	Reserved	7:0	Reserved	0x88	RW	Reserved
0x34	Reserved	7:0	Reserved	0x3F	RW	Reserved
0x35	Reserved	7:0	Reserved	0x1F	RW	Reserved
0x36	Reserved	7:0	Reserved	0x11	RW	Reserved
0x37	Reserved	7:0	Reserved	0x00	R	Reserved
0x38	Reserved	7:0	Reserved	0x00	R	Reserved

LMH1219

SNLS530D – APRIL 2016 – REVISED JUNE 2018

www.ti.com

Address	Register Name	Bit	Field	Default	Type	Description
0x39	Reserved	7:0	Reserved	0x00	R	Reserved
0x3A	Low Data Rate IN1 EQ Boost	7:6	fixed_eq_BST0	0x00	RW	Fixed IN1 CTLE setting for 270M and 1.5G SMPTE rates. If Reg 0x3F[0] = 0, Reg 0x3A fixed IN1 CTLE setting is also used for 3G rate. [7:6]: 2-bit control for Stage 0 of the CTLE [5:4]: 2-bit control for Stage 1 of the CTLE. [3:2]: 2-bit control for Stage 2 of the CTLE. [1:0]: 2-bit control for Stage 3 of the CTLE.
		5:4	fixed_eq_BST1		RW	
		3:2	fixed_eq_BST2		RW	
		1:0	fixed_eq_BST3		RW	
0x3B	Reserved	7:0	Reserved	0x96	R	Reserved
0x3C	Reserved	7:0	Reserved	0x90	R	Reserved
0x3D	Reserved	7:0	Reserved	0x00	RW	Reserved
0x3E	HEO_VEO Lock Monitor Enable	7	heo_veo_lockmon_en	0x80	RW	Enable HEO/VEO lock monitoring. Once the lock and adaptation processes are complete, HEO/VEO monitoring is performed once per the interval determined by Reg 0x69[3:0].
		6:0	Reserved		RW	
0x3F	Pin Override Register Control	7:6	Reserved	0x01	RW	Reserved
		5	mr_adapt_mode_ov		RW	0 = Normal Behavior (Automatic Adaptation when IN1 is selected) 1 = Override Automatic Adaptation for IN1. Adaptation behavior is controlled by Reg 0x31[6:5].
		4	mr_in_out_sel_ov		RW	0 = Input channel selection determined by IN_OUT_SEL pin 1 = Override input channel selection pin settings. Input selection is controlled by Reg 0x31[1:0].
		3	mr_out_ctrl_ov		RW	0 = Output mux settings determined by OUT_CTRL pin 1 = Override output mux pin settings. Output mux is controlled by Reg 0x1C[3:2].
		2	mr_refn_rate_ov		RW	0 = SMPTE or 10 GbE reference rates determined by IN_OUT_SEL pin 1 = Override reference rate pin settings. Reference rates for CDR lock are controlled by Reg 0x2F[7:6].
		1	mr_eqbst_pin_ov		RW	0 = IN1 EQ boost Bypass is controlled by OUT_CTRL pin behavior 1 = Override IN1 EQ boost pin control. IN1 EQ boost bypass characteristics are controlled by settings in Reg 0x2D[3] and Reg 0x03[7:0].
		0	mr_en_3G_divsel_eq		RW	0 = Disables IN1 EQ Adaptation for 3G data rate 1 = Enables IN1 EQ Adaptation for 3G data rate
0x40	IN1 Index 0 Boost for Adaptation	7:6	EQ_index_0_BST0	0x00	RW	Index 0 Boost [7:6]: 2-bit control for Stage 0 of the CTLE [5:4]: 2-bit control for Stage 1 of the CTLE. [3:2]: 2-bit control for Stage 2 of the CTLE. [1:0]: 2-bit control for Stage 3 of the CTLE.
		5:4	EQ_index_0_BST1		RW	
		3:2	EQ_index_0_BST2		RW	
		1:0	EQ_index_0_BST3		RW	
0x41	IN1 Index 1 Boost for Adaptation	7:6	EQ_index_1_BST0	0x40	RW	Index 1 Boost [7:6]: 2-bit control for Stage 0 of the CTLE [5:4]: 2-bit control for Stage 1 of the CTLE. [3:2]: 2-bit control for Stage 2 of the CTLE. [1:0]: 2-bit control for Stage 3 of the CTLE.
		5:4	EQ_index_1_BST1		RW	
		3:2	EQ_index_1_BST2		RW	
		1:0	EQ_index_1_BST3		RW	
0x42	IN1 Index 2 Boost for Adaptation	7:6	EQ_index_2_BST0	0x80	RW	Index 2 Boost [7:6]: 2-bit control for Stage 0 of the CTLE [5:4]: 2-bit control for Stage 1 of the CTLE. [3:2]: 2-bit control for Stage 2 of the CTLE. [1:0]: 2-bit control for Stage 3 of the CTLE.
		5:4	EQ_index_2_BST1		RW	
		3:2	EQ_index_2_BST2		RW	
		1:0	EQ_index_2_BST3		RW	
0x43	IN1 Index 3 Boost for Adaptation	7:6	EQ_index_3_BST0	0x50	RW	Index 3 Boost [7:6]: 2-bit control for Stage 0 of the CTLE [5:4]: 2-bit control for Stage 1 of the CTLE. [3:2]: 2-bit control for Stage 2 of the CTLE. [1:0]: 2-bit control for Stage 3 of the CTLE.
		5:4	EQ_index_3_BST1		RW	
		3:2	EQ_index_3_BST2		RW	
		1:0	EQ_index_3_BST3		RW	

Address	Register Name	Bit	Field	Default	Type	Description
0x44	IN1 Index 4 Boost for Adaptation	7:6	EQ_index_4_BST0	0xC0	RW	Index 4 Boost
		5:4	EQ_index_4_BST1		RW	[7:6]: 2-bit control for Stage 0 of the CTLE
		3:2	EQ_index_4_BST2		RW	[5:4]: 2-bit control for Stage 1 of the CTLE.
		1:0	EQ_index_4_BST3		RW	[3:2]: 2-bit control for Stage 2 of the CTLE. [1:0]: 2-bit control for Stage 3 of the CTLE.
0x45	IN1 Index 5 Boost for Adaptation	7:6	EQ_index_5_BST0	0x90	RW	Index 5 Boost
		5:4	EQ_index_5_BST1		RW	[7:6]: 2-bit control for Stage 0 of the CTLE
		3:2	EQ_index_5_BST2		RW	[5:4]: 2-bit control for Stage 1 of the CTLE.
		1:0	EQ_index_5_BST3		RW	[3:2]: 2-bit control for Stage 2 of the CTLE. [1:0]: 2-bit control for Stage 3 of the CTLE.
0x46	IN1 Index 6 Boost for Adaptation	7:6	EQ_index_6_BST0	0x54	RW	Index 6 Boost
		5:4	EQ_index_6_BST1		RW	[7:6]: 2-bit control for Stage 0 of the CTLE
		3:2	EQ_index_6_BST2		RW	[5:4]: 2-bit control for Stage 1 of the CTLE.
		1:0	EQ_index_6_BST3		RW	[3:2]: 2-bit control for Stage 2 of the CTLE. [1:0]: 2-bit control for Stage 3 of the CTLE.
0x47	IN1 Index 7 Boost for Adaptation	7:6	EQ_index_7_BST0	0xA0	RW	Index 7 Boost
		5:4	EQ_index_7_BST1		RW	[7:6]: 2-bit control for Stage 0 of the CTLE
		3:2	EQ_index_7_BST2		RW	[5:4]: 2-bit control for Stage 1 of the CTLE.
		1:0	EQ_index_7_BST3		RW	[3:2]: 2-bit control for Stage 2 of the CTLE. [1:0]: 2-bit control for Stage 3 of the CTLE.
0x48	IN1 Index 8 Boost for Adaptation	7:6	EQ_index_8_BST0	0xB0	RW	Index 8 Boost
		5:4	EQ_index_8_BST1		RW	[7:6]: 2-bit control for Stage 0 of the CTLE
		3:2	EQ_index_8_BST2		RW	[5:4]: 2-bit control for Stage 1 of the CTLE.
		1:0	EQ_index_8_BST3		RW	[3:2]: 2-bit control for Stage 2 of the CTLE. [1:0]: 2-bit control for Stage 3 of the CTLE.
0x49	IN1 Index 9 Boost for Adaptation	7:6	EQ_index_9_BST0	0x95	RW	Index 9 Boost
		5:4	EQ_index_9_BST1		RW	[7:6]: 2-bit control for Stage 0 of the CTLE
		3:2	EQ_index_9_BST2		RW	[5:4]: 2-bit control for Stage 1 of the CTLE.
		1:0	EQ_index_9_BST3		RW	[3:2]: 2-bit control for Stage 2 of the CTLE. [1:0]: 2-bit control for Stage 3 of the CTLE.
0x4A	IN1 Index 10 Boost for Adaptation	7:6	EQ_index_10_BST0	0x69	RW	Index 10 Boost
		5:4	EQ_index_10_BST1		RW	[7:6]: 2-bit control for Stage 0 of the CTLE
		3:2	EQ_index_10_BST2		RW	[5:4]: 2-bit control for Stage 1 of the CTLE.
		1:0	EQ_index_10_BST3		RW	[3:2]: 2-bit control for Stage 2 of the CTLE. [1:0]: 2-bit control for Stage 3 of the CTLE.
0x4B	IN1 Index 11 Boost for Adaptation	7:6	EQ_index_11_BST0	0xD5	RW	Index 11 Boost
		5:4	EQ_index_11_BST1		RW	[7:6]: 2-bit control for Stage 0 of the CTLE
		3:2	EQ_index_11_BST2		RW	[5:4]: 2-bit control for Stage 1 of the CTLE.
		1:0	EQ_index_11_BST3		RW	[3:2]: 2-bit control for Stage 2 of the CTLE. [1:0]: 2-bit control for Stage 3 of the CTLE.
0x4C	IN1 Index 12 Boost for Adaptation	7:6	EQ_index_12_BST0	0x99	RW	Index 12 Boost
		5:4	EQ_index_12_BST1		RW	[7:6]: 2-bit control for Stage 0 of the CTLE
		3:2	EQ_index_12_BST2		RW	[5:4]: 2-bit control for Stage 1 of the CTLE.
		1:0	EQ_index_12_BST3		RW	[3:2]: 2-bit control for Stage 2 of the CTLE. [1:0]: 2-bit control for Stage 3 of the CTLE.
0x4D	IN1 Index 13 Boost for Adaptation	7:6	EQ_index_13_BST0	0xA5	RW	Index 13 Boost
		5:4	EQ_index_13_BST1		RW	[7:6]: 2-bit control for Stage 0 of the CTLE
		3:2	EQ_index_13_BST2		RW	[5:4]: 2-bit control for Stage 1 of the CTLE.
		1:0	EQ_index_13_BST3		RW	[3:2]: 2-bit control for Stage 2 of the CTLE. [1:0]: 2-bit control for Stage 3 of the CTLE.
0x4E	IN1 Index 14 Boost for Adaptation	7:6	EQ_index_14_BST0	0xE6	RW	Index 14 Boost
		5:4	EQ_index_14_BST1		RW	[7:6]: 2-bit control for Stage 0 of the CTLE
		3:2	EQ_index_14_BST2		RW	[5:4]: 2-bit control for Stage 1 of the CTLE.
		1:0	EQ_index_14_BST3		RW	[3:2]: 2-bit control for Stage 2 of the CTLE. [1:0]: 2-bit control for Stage 3 of the CTLE.
0x4F	IN1 Index 15 Boost for Adaptation	7:6	EQ_index_15_BST0	0xF9	RW	Index 15 Boost
		5:4	EQ_index_15_BST1		RW	[7:6]: 2-bit control for Stage 0 of the CTLE
		3:2	EQ_index_15_BST2		RW	[5:4]: 2-bit control for Stage 1 of the CTLE.
		1:0	EQ_index_15_BST3		RW	[3:2]: 2-bit control for Stage 2 of the CTLE. [1:0]: 2-bit control for Stage 3 of the CTLE.
0x50	Reserved	7:0	Reserved	0x00	RW	Reserved

LMH1219

SNLS530D – APRIL 2016 – REVISED JUNE 2018

www.ti.com

Address	Register Name	Bit	Field	Default	Type	Description
0x51	Reserved	7:0	Reserved	0x00	RW	Reserved
0x52	IN1 Active EQ Readback	7:0	eq_bst_to_ana	0x00	R	IN1 CTLE boost setting readback from Active CTLE Adaptation.
0x53	Reserved	7:0	Reserved	0x00	R	Reserved
0x54	Interrupt Status Register	7	cardet	0x00	R	0 = Carrier Detect from the selected input de-asserted 1 = Carrier Detect from the selected input asserted Note: Clears when Reg 0x54 is read-back.
		6	cdr_lock_int		R	0 = No interrupt from CDR Lock 1 = CDR Lock Interrupt Note: Clears when Reg 0x54 is read-back.
		5	carrier_det1_int		R	0 = No interrupt from IN1 Carrier Detect 1 = IN1 Carrier Detect Interrupt Note: Clears when Reg 0x54 is read-back.
		4	carrier_det0_int		R	0 = No interrupt from IN0 Carrier Detect 1 = IN0 Carrier Detect Interrupt Note: Clears when Reg 0x54 is read-back.
		3	heo_veo_int		R	0 = No interrupt from HEO/VEO 1 = HEO/VEO Threshold Reached Interrupt Note: Clears when Reg 0x54 is read-back.
		2	cdr_lock_loss_int		R	0 = No interrupt from CDR Lock 1 = CDR Loss of Lock Interrupt Note: Clears when Reg 0x54 is read-back.
		1	carrier_det1_loss_int		R	0 = No interrupt from IN1 Carrier Detect 1 = IN1 Carrier Detect Loss Interrupt Note: Clears when Reg 0x54 is read-back.
		0	carrier_det0_loss_int		R	0 = No interrupt from IN0 Carrier Detect 1 = IN0 Carrier Detect Loss Interrupt Note: Clears when Reg 0x54 is read-back.
0x55	Reserved	7:0	Reserved	0x02	R	Reserved
0x56	Interrupt Control Register	7	Reserved	0x00	RW	Reserved
		6	cdr_lock_int_en		RW	0 = Disable interrupt if CDR lock is achieved 1 = Enable interrupt if CDR lock is achieved
		5	carrier_det1_int_en		RW	0 = Disable interrupt if IN1 Carrier Detect is asserted 1 = Enable interrupt if IN1 Carrier Detect is asserted
		4	carrier_det0_int_en		RW	0 = Disable interrupt if IN0 Carrier Detect is asserted 1 = Enable interrupt if IN0 Carrier Detect is asserted
		3	heo_veo_int_en		RW	0 = Disable interrupt if HEO/VEO threshold is reached 1 = Enable interrupt if HEO/VEO threshold is reached
		2	cdr_lock_loss_int_en		RW	0 = Disable interrupt if CDR loses lock 1 = Enable interrupt if CDR loses lock
		1	carrier_det1_loss_int_en		RW	0 = Disable interrupt if there is loss of signal (LOS) on IN1 1 = Enable interrupt if there is loss of signal (LOS) on IN1
		0	carrier_det0_loss_int_en		RW	0 = Disable interrupt if there is loss of signal (LOS) on IN0 1 = Enable interrupt if there is loss of signal (LOS) on IN0
0x60	Reserved	7:0	Reserved	0x26	RW	Reserved
0x61	Reserved	7:0	Reserved	0x31	RW	Reserved
0x62	Reserved	7:0	Reserved	0x70	RW	Reserved
0x63	Reserved	7:0	Reserved	0x3D	RW	Reserved
0x64	Reserved	7:0	Reserved	0xFF	RW	Reserved
0x65	Reserved	7:0	Reserved	0x00	RW	Reserved
0x66	Reserved	7:0	Reserved	0x00	RW	Reserved
0x67	Reserved	7:0	Reserved	0x00	RW	Reserved
0x68	Reserved	7:0	Reserved	0x00	RW	Reserved

Address	Register Name	Bit	Field	Default	Type	Description
0x69	HEO_VEO Lock Monitor	7:4	Reserved	0x0A	RW	Reserved
		3:0	hv_lckmon_cnt_ms		RW	While monitoring lock, these bits set the amount of interval times to monitor HEO or VEO lock. Each interval is 6.5 ms. Therefore, by default, Reg 0x69[3:0] = 1010'b causes HEO_VEO lock monitor to occur once every 65 ms.
0x6A	HEO and VEO Lock Threshold	7:4	veo_lck_thrsh	0x44	RW	HEO/VEO lock thresholds. Lock will not be declared until $HEO \geq (heo_lck_thrsh \times 4)$ and $VEO \geq (veo_lck_thrsh \times 4)$.
		3:0	heo_lck_thrsh		RW	
0x6B	Reserved	7:0	Reserved	0x40	RW	Reserved
0x6C	Reserved	7:0	Reserved	0x00	RW	Reserved
0x6D	Reserved	7:0	Reserved	0x00	RW	Reserved
0x6E	Reserved	7:0	Reserved	0x00	RW	Reserved
0x6F	Reserved	7:0	Reserved	0x00	RW	Reserved
0x70	Reserved	7:0	Reserved	0x03	RW	Reserved
0x71	Reserved	7:0	Reserved	0x20	R	Reserved
0x72	Reserved	7:0	Reserved	0x00	RW	Reserved
0x73	Reserved	7:0	Reserved	0x00	RW	Reserved
0x74	Reserved	7:0	Reserved	0x00	RW	Reserved
0x75	Reserved	7:0	Reserved	0x00	RW	Reserved
0x77	Reserved	7:0	Reserved	0x00	RW	Reserved
0x80	Reserved	7:0	Reserved	0x50	RW	Reserved
0x81	Reserved	7:0	Reserved	0x00	RW	Reserved
0x82	Reserved	7:0	Reserved	0x80	RW	Reserved
0x83	Reserved	7:0	Reserved	0x70	RW	Reserved
0x84	Reserved	7:0	Reserved	0x04	RW	Reserved
0x85	Reserved	7:0	Reserved	0x00	RW	Reserved
0x87	Reserved	7:0	Reserved	0x00	RW	Reserved
0x90	Reserved	7:0	Reserved	0xA5	RW	Reserved
0x91	Reserved	7:0	Reserved	0x23	RW	Reserved
0x92	Reserved	7:0	Reserved	0x2C	RW	Reserved
0x93	Reserved	7:0	Reserved	0x32	RW	Reserved
0x94	Reserved	7:0	Reserved	0x37	RW	Reserved
0x95	Reserved	7:0	Reserved	0x3E	RW	Reserved
0x98	Reserved	7:0	Reserved	0x3F	RW	Reserved
0x99	Reserved	7:0	Reserved	0x04	RW	Reserved
0x9A	Reserved	7:0	Reserved	0x04	RW	Reserved
0x9B	Reserved	7:0	Reserved	0x04	RW	Reserved
0x9C	Reserved	7:0	Reserved	0x06	RW	Reserved
0x9D	Reserved	7:0	Reserved	0x04	RW	Reserved
0x9E	Reserved	7:0	Reserved	0x04	RW	Reserved
0xA0	SMPTE Data Rate Lock Enable	7:5	Reserved	0x1F	RW	Reserved
		4	dvb_enable		RW	0 = Disable CDR Lock to 270 Mbps 1 = Enable CDR Lock to 270 Mbps
		3	hd_enable		RW	0 = Disable CDR Lock to 1.485/1.4835 Gbps 1 = Enable CDR Lock to 1.485/1.4835 Gbps
		2	3G_enable		RW	0 = Disable CDR Lock to 2.97/2.967 Gbps 1 = Enable CDR Lock to 2.97/2.967 Gbps
		1	6G_enable		RW	0 = Disable CDR Lock to 5.94/5.934 Gbps 1 = Enable CDR Lock to 5.94/5.934 Gbps
		0	12G_enable		RW	0 = Disable CDR Lock to 11.88/11.868 Gbps 1 = Enable CDR Lock to 11.88/11.868 Gbps

LMH1219

SNLS530D – APRIL 2016 – REVISED JUNE 2018

www.ti.com**7.5.3 CableEQ/Drivers Register Page**

Address	Register Name	Bit	Field	Default	Type	Description
0x00	Reset CableEQ/Drivers Registers	7	adapt_cd	0x08	RW	LOCK_N pin status 0 = LOCK_N indicates when Coarse Adaptation for IN0 is done 1 = LOCK_N indicates carrier detect (CD_N) for IN0
		6	Reserved		RW	Reserved
		5	reg_power_save_ov		RW	IN0 Power Save Override Control for Cable EQ 0 = Disable Power Save Mode override. Automatic Power Save when no input signal detected. 1 = Enable Power Save Mode override. Power Save mode control set by value in Reg 0x00[4:3]. Note: Unused input is always powered down automatically.
		4:3	reg_power_save		RW	IN0 Auto Power Save Mode control for Cable EQ if Reg 0x00[5] = 1 00 = Enable Power Save Mode when no input signal is detected 01 = Disable auto Power Save Mode (disable power down) 10 = Reserved 11 = Force Power Save Mode Note: Unused input is always powered down automatically.
		2	rst_cableEQ/Drivers_ regs		RW	Reset registers (self-clearing) 0 = Normal operation 1 = Reset CableEQ/Drivers Registers. Register re-initialization procedure required after resetting the CableEQ/Drivers Registers. Refer to the LMH1219 Programming Guide for details.
		1:0	Reserved		RW	Reserved
0x01	EQ Observation Status	7:1	Reserved	0x80	R	Reserved
		0	adaptation_status		R	0 = Adaptation not completed 1 = Adaptation completed
0x02	Rate and Driver Observation Status	7	Reserved	0x07	R	Reserved
		6	IN0 Carrier Detect		R	Carrier Detect Status of IN0 0 = No signal present at IN0 1 = Signal present at IN0
		5:3	freq_rate_det		R	Readback of rate detected 001 = 125M-270M 010 = 1.5G-3G 100 = 6G-12G
		2	power_save_status		R	Observation Bit 0 = Power Save Mode is Inactive 1 = Power Save Mode is Active
		1	mute_tx1		R	Observation Bit 0 = OUT1 Driver is Active 1 = OUT1 Driver is in Mute Note: When muted, driver output remains at common mode voltage.
		0	mute_tx0		R	Observation Bit 0 = OUT0 Driver is Active 1 = OUT0 Driver is in Mute Note: When muted, driver output remains at common mode voltage.
0x03	MUTERef Control	7:6	Reserved	0x3F	RW	Reserved
		5:0	MUTERef		RW	Digital MUTERef sets the threshold at which the output will be muted. See the "Digital MUTE _{REF} " subsection of the LMH1219 datasheet for more information.
0x04	Reserved	7:0	Reserved	0x00	RW	Reserved
0x05	Reserved	7:0	Reserved	0x00	RW	Reserved
0x06	Reserved	7:0	Reserved	0xA0	RW	Reserved
0x07	Reserved	7:0	Reserved	0x24	RW	Reserved
0x08	Reserved	7:0	Reserved	0x27	RW	Reserved

Address	Register Name	Bit	Field	Default	Type	Description
0x09	Reserved	7:0	Reserved	0x01	RW	Reserved
0x0A	Reserved	7:0	Reserved	0x05	RW	Reserved
0x0B	Reserved	7:0	Reserved	0x37	RW	Reserved
0x0C	Reserved	7:0	Reserved	0x01	RW	Reserved
0x0D	Reserved	7:0	Reserved	0x25	RW	Reserved
0x0E	Reserved	7:0	Reserved	0x37	RW	Reserved
0x0F	Reserved	7:0	Reserved	0x02	RW	Reserved
0x10	Reserved	7:0	Reserved	0x0A	RW	Reserved
0x11	Reserved	7:0	Reserved	0x02	RW	Reserved
0x12	Reserved	7:0	Reserved	0x08	RW	Reserved
0x13	Reserved	7:0	Reserved	0x04	RW	Reserved
0x14	Reserved	7:0	Reserved	0x3C	RW	Reserved
0x15	Reserved	7:0	Reserved	0x00	RW	Reserved
0x16	Reserved	7:0	Reserved	0x00	RW	Reserved
0x17	Reserved	7:0	Reserved	0x08	RW	Reserved
0x18	Reserved	7:0	Reserved	0x01	RW	Reserved
0x19	Reserved	7:0	Reserved	0x08	RW	Reserved
0x1A	Reserved	7:0	Reserved	0x01	RW	Reserved
0x1B	Reserved	7:0	Reserved	0xA7	RW	Reserved
0x1C	Reserved	7:0	Reserved	0x00	RW	Reserved
0x1D	Reserved	7:0	Reserved	0x00	RW	Reserved
0x1E	Reserved	7:0	Reserved	0x00	RW	Reserved
0x1F	Reserved	7:0	Reserved	0x00	RW	Reserved
0x20	Reserved	7:0	Reserved	0x00	RW	Reserved
0x21	Reserved	7:0	Reserved	0xC0	RW	Reserved
0x22	Reserved	7:0	Reserved	0x00	RW	Reserved
0x23	Reserved	7:0	Reserved	0x00	RW	Reserved
0x24	Reserved	7:0	Reserved	0x00	RW	Reserved
0x25	Cable Length Indicator	7:6	Reserved	0x00	R	Reserved
		5:0	CLI		R	Readback of Cable Length Indicator (CLI) after adaptation. See the "Cable Length Indicator (CLI)" subsection of the LMH1219 datasheet for more information.
0x26	Reserved	7:0	Reserved	0x05	R	Reserved
0x27	EQ Bypass Override	7:4	Reserved	0x00	RW	Reserved
		3	eq_bypass_ov		RW	Override eq_bypass value to analog core 0 = Disable EQ Bypass override 1 = Enable EQ Bypass override. Value of EQ Bypass Control determined by Reg 0x27[2].
		2	eq_bypass_val		RW	Override value of eq_bypass 0 = Do not Bypass Cable EQ. Use Adaptive EQ 1 = Bypass Cable EQ
		1:0	Reserved		RW	Reserved
0x28	Reserved	7:0	Reserved	0x00	RW	Reserved
0x29	Reserved	7:0	Reserved	0x20	R	Reserved
0x2A	Reserved	7:0	Reserved	0x40	RW	Reserved
0x2B	Reserved	7:0	Reserved	0x89	RW	Reserved
0x2C	Reserved	7:0	Reserved	0x0B	RW	Reserved
0x2D	Reserved	7:0	Reserved	0x20	RW	Reserved
0x2E	Reserved	7:0	Reserved	0x00	R	Reserved
0x2F	Reserved	7:0	Reserved	0x00	RW	Reserved

LMH1219

SNLS530D – APRIL 2016 – REVISED JUNE 2018

www.ti.com

Address	Register Name	Bit	Field	Default	Type	Description
0x30	OUT0 Output Control	7	tx0_mute_ov	0x0A	RW	OUT0 Mute Override Control 0 = Disable OUT0 Mute Override Control 1 = Enable OUT0 Mute Override Control by value in Reg 0x30[6].
		6	tx0_mute_val		RW	0 = Normal Operation 1 = Mute OUT0 if Reg 0x30[7] = 1
		5	tx0_vod_ov		RW	OUT0 VOD Override Control 0 = VOD settings for OUT0 determined by VOD_DE pin 1 = Override VOD pin settings for OUT0. VOD settings for OUT0 are controlled by Reg 0x30[2:0]
		4:3	Reserved		RW	Reserved
		2:0	tx0_vod		RW	VOD settings for OUT0 if Reg 0x30[5] = 1. See the "Output Amplitude vs. VOD Register Settings" graph in the Typical Characteristics subsection of the LMH1219 datasheet for more information.
0x31	OUT0 De-Emphasis Control	7	Reserved	0x01	RW	Reserved
		6	tx0_dem_ov		RW	OUT0 De-Emphasis Override Control 0 = De-emphasis for OUT0 determined by VOD_DE pin 1 = Override De-emphasis settings for OUT0. De-emphasis settings for OUT0 are controlled by Reg 0x31[2:0]
		5	tx0_PD_ov		RW	OUT0 Power Down Override Control 0 = Disable OUT0 Power Down Override Control 1 = Enable OUT0 Power Down Override Control by value in Reg 0x31[4]
		4	tx0_PD		RW	0 = Normal Operation 1 = Power Down OUT0 if Reg 0x31[5] = 1
		3	Reserved		RW	Reserved
		2:0	tx0_dem		RW	De-emphasis settings for OUT0 if Reg 0x31[6] = 1. See the "Output De-emphasis vs. VOD Register Settings" graph in the Typical Characteristics subsection of the LMH1219 datasheet for more information.
0x32	OUT1 Output Control	7	tx1_mute_ov	0x0A	RW	OUT1 Mute Override Control 0 = Disable OUT1 Mute Override Control 1 = Enable OUT1 Mute Override Control by value in Reg 0x32[6].
		6	tx1_mute_val		RW	0 = Normal Operation 1 = Mute OUT1 if Reg 0x32[7] = 1
		5	tx1_vod_ov		RW	OUT1 VOD Override Control 0 = VOD settings for OUT1 determined by VOD_DE pin 1 = Override VOD pin settings for OUT1. VOD settings for OUT1 are controlled by Reg 0x32[2:0]
		4:3	Reserved		RW	Reserved
		2:0	tx1_vod		RW	VOD settings for OUT0 if Reg 0x32[5] = 1. See the "Output Amplitude vs. VOD Register Settings" graph in the Typical Characteristics subsection of the LMH1219 datasheet for more information.

Address	Register Name	Bit	Field	Default	Type	Description
0x33	OUT1 De-Emphasis Control	7	Reserved	0x11	RW	Reserved
		6	tx1_dem_ov		RW	OUT1 De-Emphasis Override Control 0 = De-emphasis for OUT1 determined by VOD_DE pin 1 = Override De-emphasis settings for OUT1. De-emphasis settings for OUT1 are controlled by Reg 0x33[2:0]
		5	tx1_PD_ov		RW	OUT1 Power Down Override Control 0 = Disable OUT1 Power Down Override Control 1 = Enable OUT1 Power Down Override Control by value in Reg 0x33[4].
		4	tx1_PD		RW	0 = Normal Operation 1 = Power Down OUT1 if Reg 0x33[5] = 1
		3	Reserved		RW	Reserved
		2:0	tx1_dem		RW	De-emphasis settings for OUT1 if Reg 0x33[6] = 1. See the "Output De-emphasis vs. VOD Register Settings" graph in the Typical Characteristics subsection of the LMH1219 datasheet for more information.
0x34	Splitter_Reg	7	hi_gain_mode	0x17	RW	-6 dB Launch Amplitude Adaptation Mode 0 = Enable EQ adaptation with nominal 800 mV launch amplitude 1 = Enable EQ adaptation with 400 mV launch amplitude
		6:0	Reserved			Reserved
0x35	Reserved	7:0	Reserved	0x61	RW	Reserved
0x36	Reserved	7:0	Reserved	0x02	RW	Reserved
0x37	Reserved	7:0	Reserved	0x00	RW	Reserved
0x38	Reserved	7:0	Reserved	0x00	RW	Reserved
0x39	Reserved	7:0	Reserved	0x00	RW	Reserved
0x3A	Reserved	7:0	Reserved	0x00	RW	Reserved
0x3B	Reserved	7:0	Reserved	0x00	RW	Reserved
0x3C	Reserved	7:0	Reserved	0x00	RW	Reserved
0x3D	Reserved	7:0	Reserved	0x7F	RW	Reserved
0x3E	Reserved	7:0	Reserved	0x00	RW	Reserved
0x3F	Reserved	7:0	Reserved	0x00	RW	Reserved
0x40	Reserved	7:0	Reserved	0x00	R	Reserved
0x41	Reserved	7:0	Reserved	0x00	R	Reserved
0x42	Reserved	7:0	Reserved	0x00	R	Reserved
0x43	Reserved	7:0	Reserved	0x00	R	Reserved
0x44	Reserved	7:0	Reserved	0x00	R	Reserved
0x45	Reserved	7:0	Reserved	0x00	R	Reserved
0x46	Reserved	7:0	Reserved	0x00	R	Reserved
0x47	Reserved	7:0	Reserved	0x00	R	Reserved
0x48	Reserved	7:0	Reserved	0x00	R	Reserved
0x49	Reserved	7:0	Reserved	0x01	R	Reserved
0x4A	Reserved	7:0	Reserved	0x00	R	Reserved
0x4B	Reserved	7:0	Reserved	0x00	R	Reserved
0x4C	Reserved	7:0	Reserved	0x00	R	Reserved
0x4D	Reserved	7:0	Reserved	0x00	RW	Reserved
0x4E	Reserved	7:0	Reserved	0x00	RW	Reserved
0x4F	Reserved	7:0	Reserved	0x00	RW	Reserved
0x50	Reserved	7:0	Reserved	0x00	RW	Reserved
0x51	Reserved	7:0	Reserved	0x00	RW	Reserved
0x52	Reserved	7:0	Reserved	0x00	RW	Reserved
0x53	Reserved	7:0	Reserved	0x00	RW	Reserved
0x54	Reserved	7:0	Reserved	0x0F	R	Reserved

LMH1219

SNLS530D – APRIL 2016 – REVISED JUNE 2018

www.ti.com

8 Application and Implementation

NOTE

Information in the following applications sections is not part of the TI component specification, and TI does not warrant its accuracy or completeness. TI's customers are responsible for determining suitability of components for their purposes. Customers should validate and test their design implementation to confirm system functionality.

8.1 Application Information

8.1.1 General Guidance for SMPTE and 10 GbE Applications

SMPTE specifies the requirements for the Serial Digital Interface to transport digital video over coaxial cables. One of the requirements is meeting return loss, which specifies how closely the port resembles 75-Ω impedance across a specified frequency band. The SMPTE specifications also defines the use of AC coupling capacitors for transporting uncompressed serial data streams with heavy low frequency content. The use of 4.7-μF AC coupling capacitors is recommended to avoid low frequency DC wander. SFF-8431 (SFP+) requires the 100-Ω transmit signal to meet the electrical, return loss, jitter, and eye mask specifications. TI recommends placing the LMH1219 as close as possible to the 75-Ω BNC and 100-Ω SFP+ optical module in order to meet the specifications for SMPTE and SFF-8431. Refer to [Table 9](#) for design guidelines.

8.1.2 Optimizing Time to Adapt and Lock

When carrier detect is asserted the LMH1219 continuously adapts the cable equalizer to the optimal gain and bandwidth. The time required to adapt the equalizer and achieve lock to the incoming signal can be optimized by manually programming the highest data rate expected in the application. Refer to LMH1219 programming guide for more details.

8.1.3 LMH1219 and LMH0324 Compatibility

The LMH1219 is pin compatible with the LMH0324 (3 Gbps adaptive cable equalizer) when the LMH0324 RSV_L pin is tied to 2.5 V. This pin compatibility allows users to upgrade easily from a 3 Gbps equalizer to a 12 Gbps UHD equalizer with integrated reclocker. See [Figure 21](#) for details.

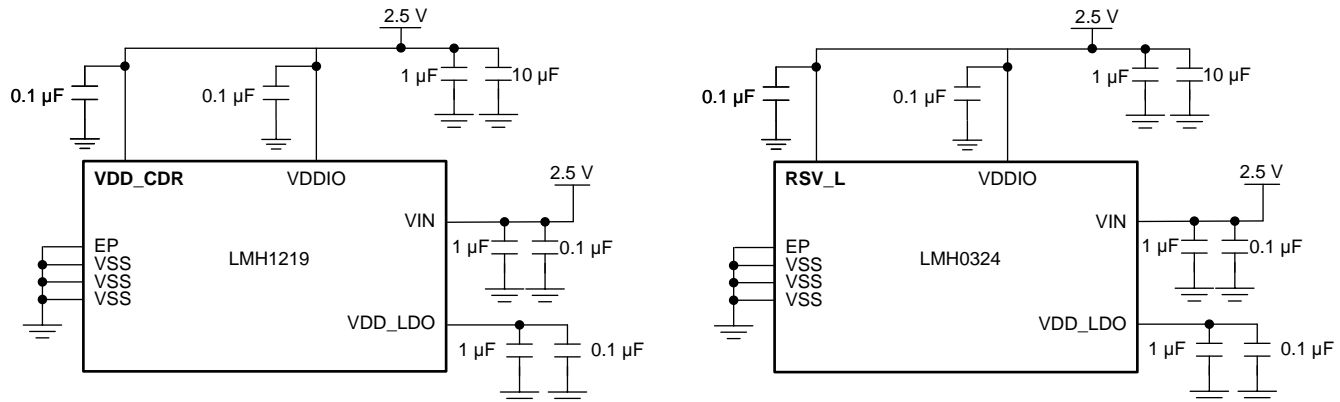

Figure 21. Pin Connections for LMH1219 and LMH0324 Compatibility

8.2 Typical Application

The LMH1219 is a low-power cable equalizer with integrated reclocker that supports SDI data rates up to 11.88 Gbps and 10 GbE. [Figure 22](#) shows a typical implementation of the LMH1219 as a SDI adaptive cable equalizer at IN0+. Signal attenuated by a long coax cable is applied to the LMH1219 at the BNC port. Signal from a 10 GbE optical module is connected to the input port at IN1±. Equalized and reclocked data is output at OUT0± and OUT1± to a downstream video processor.

Typical Application (continued)

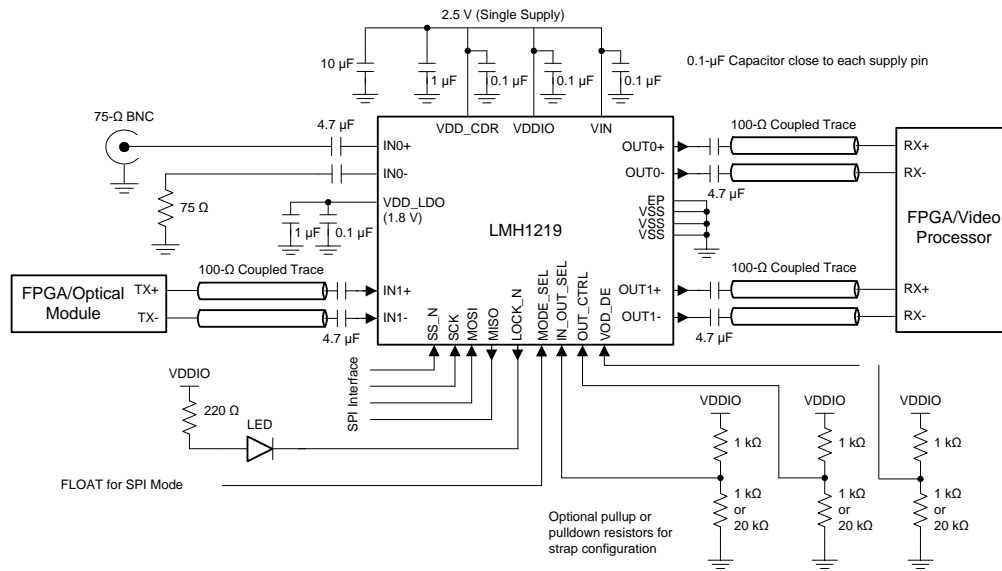

Figure 22. LMH1219 SPI Mode Connection Diagram

8.2.1 Design Requirements

Table 9. LMH1219 Design Requirements

DESIGN PARAMETER	REQUIREMENTS
IN0+ Input AC coupling capacitor	AC Coupling capacitor at IN0+ should be a 4.7-µF capacitor. Choose a small 0402 surface mount ceramic capacitor. IN0- should be AC terminated with 4.7 µF and 75 Ω to VSS.
IN1± Input AC coupling capacitors	AC Coupling capacitors at IN1± should be 4.7-µF capacitors. Choose small 0402 surface mount ceramic capacitors. This allows both SMPTE and 10 GbE data traffic.
Output AC coupling capacitors	Both OUT0± and OUT1± require AC coupling capacitors. Choose small 0402 surface mount ceramic capacitors. 4.7-µF AC coupling capacitors are recommended.
DC power supply decoupling capacitors	Decoupling capacitors are required to minimize power supply noise. Place 10-µF and 1-µF bulk capacitors close to each device. Place a 0.1-µF capacitor close to each supply pin.
VDD_LDO decoupling capacitors	Place 1-µF and 0.1-µF surface mount ceramic capacitors as close as possible to the device VDD_LDO pin.
High speed board trace for IN0	IN0+ and IN0- should be routed with uncoupled board traces with 75-Ω characteristic impedance.
High Speed IN1, OUT0, and OUT1 trace impedance	IN1±, OUT0± and OUT1± should be routed with coupled board traces with 100-Ω differential impedance.
SMPTE return loss	Place BNC within 1 inch of the LMH1219 and consult BNC vendor for recommended BNC landing pattern to meet SMPTE requirements.
IN0+ and IN1± cross talk	When a long length coax cable is connected to IN0+, the signal amplitude at IN0+ can be just a few mVp-p. Layout precautions must be taken to minimize crosstalk from adjacent devices or from adjacent input port IN1±. To reduce cross coupling effects, keep IN1± traces as far from IN0± as possible. When IN1± is not used, it is recommended to turn off the signal source to IN1± for best results.
Use of SPI or SMBus interface	Set MODE_SEL to Level-F (pin unconnected) for SPI. Set MODE_SEL to Level-L (connect 1 kΩ to VSS) for SMBus. SMBus is 3.3 V tolerant.

8.2.2 Detail Design Procedure

The following general design procedure is recommended:

1. Select a suitable power supply voltage for the LMH1219. See [Power Supply Recommendations](#) for details.
2. Check that the power supply meets the DC and AC requirements in [Recommended Operating Conditions](#).
3. Select the proper pull-high or pull-low resistors for IN_OUT_SEL and OUT_CTRL for setting the signal path.

LMH1219

SNLS530D – APRIL 2016 – REVISED JUNE 2018

www.ti.com

4. If -6 dB launch amplitude or other expanded programmable features are needed, select the use of SPI or SMBus by setting Level-F or Level-L for MODE_SEL, respectively.
5. Choose a high quality 75-Ω BNC that is capable of supporting 11.88 Gbps applications. Consult a BNC supplier regarding insertion loss, impedance specifications, and recommended footprint for meeting SMPTE return loss.
6. Depending on the length and insertion loss of the output traces for OUT0± and OUT1±, select the proper pull-high or pull-low resistors for VOD_DE to set the output amplitude and de-emphasis settings. Refer to [Table 5](#) for details.
7. Follow all design requirements detailed in [Table 9](#) to optimize LMH1219 performance.
8. For additional layout recommendations, refer to [PCB Layout Guidelines](#).

8.2.3 Recommended VOD and DEM Register Settings

[Table 10](#) shows recommended output amplitude and de-emphasis register settings for most applications.

Table 10. VOD and DEM Register Settings

VOD REG SETTING OUT0±: 0x30[5]=1, 0x30[2:0] OUT1±: 0x32[5]=1, 0x32[2:0]	DEM REG SETTING OUT0±: 0x31[6]=1, 0x31[2:0] OUT1±: 0x33[6]=1, 0x33[2:0]	VOD (mVpp)	DEM (dB)
0	0	410	0
1	1	486	-0.1
2	1	560	-0.1
2	2	560	-0.9
3	1	635	-0.3
3	2	635	-1.3
3	3	635	-2.4
4	1	716	-0.5
4	2	716	-1.8
4	3	716	-3.0
4	4	716	-4.0
5	1	810	-0.8
5	2	810	-2.4
5	3	810	-3.6
5	4	810	-4.6
5	5	810	-6.1
6	1	880	-1.0
6	2	880	-2.7
6	3	880	-4.0
6	4	880	-5.0
6	5	880	-6.5
7	1	973	-1.2
7	2	973	-3.1
7	3	973	-4.6
7	4	973	-5.7
7	5	973	-7.1

8.2.4 Application Performance Plots

Depending on the selected input, the LMH1219 performance was measured with the test setups shown in [Figure 23](#) and [Figure 24](#).

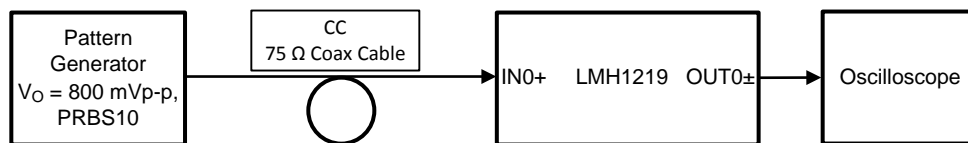
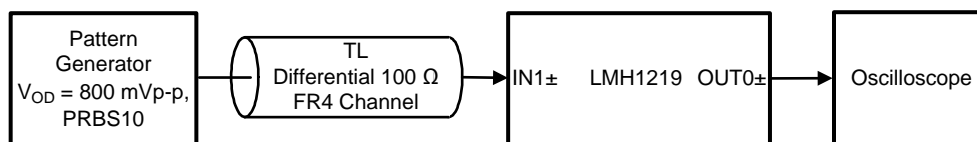
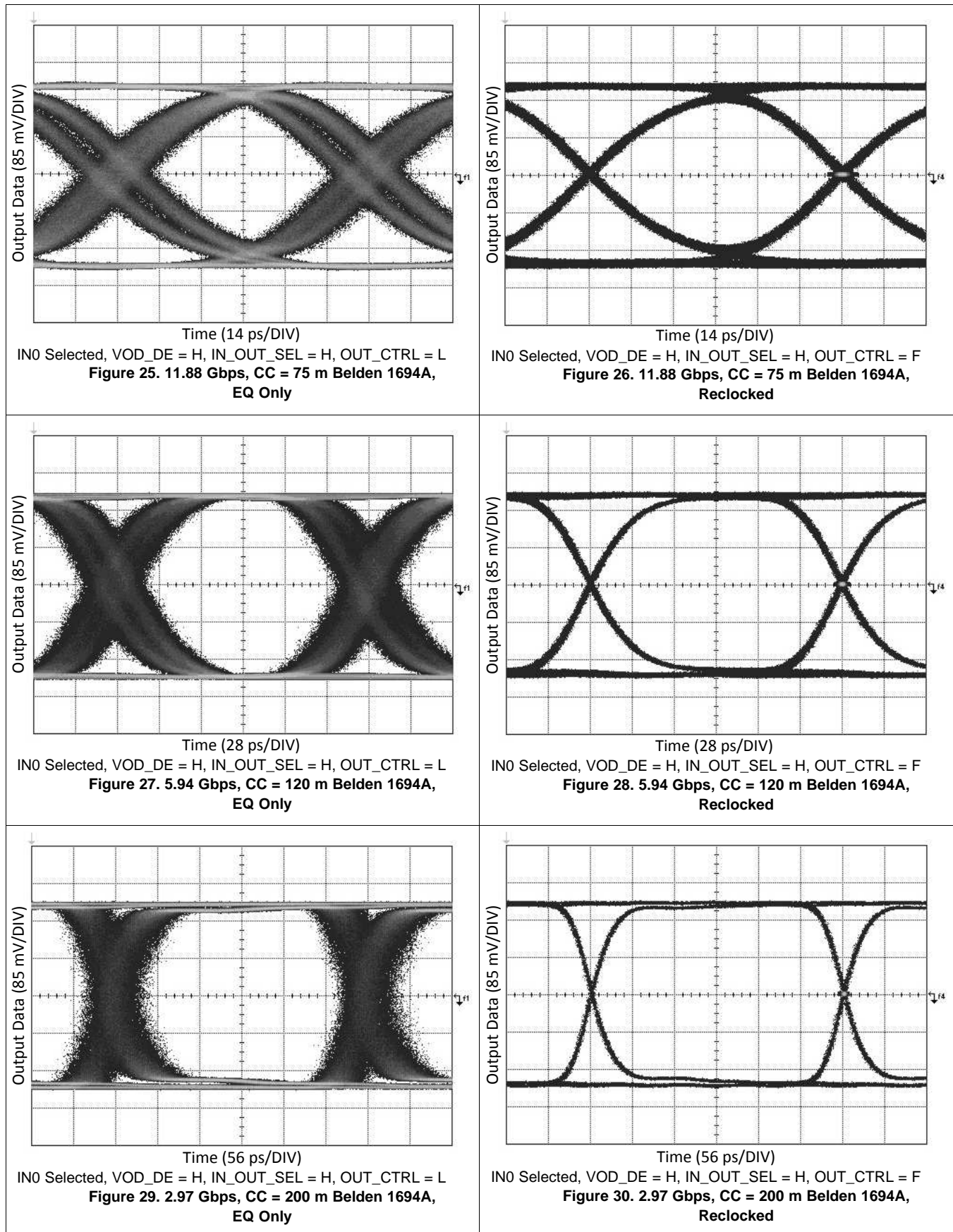

Figure 23. Test Setup for LMH1219 Cable Equalizer (IN0+)

Figure 24. Test Setup for LMH1219 PCB Equalizer (IN1±)

The eye diagrams in this subsection show how the LMH1219 improves overall signal integrity in the data path for 75-Ω coax cable input length (CC) when IN0 is selected and 100-Ω differential FR4 PCB trace when IN1 is selected.

LMH1219

SNLS530D – APRIL 2016 – REVISED JUNE 2018

www.ti.com



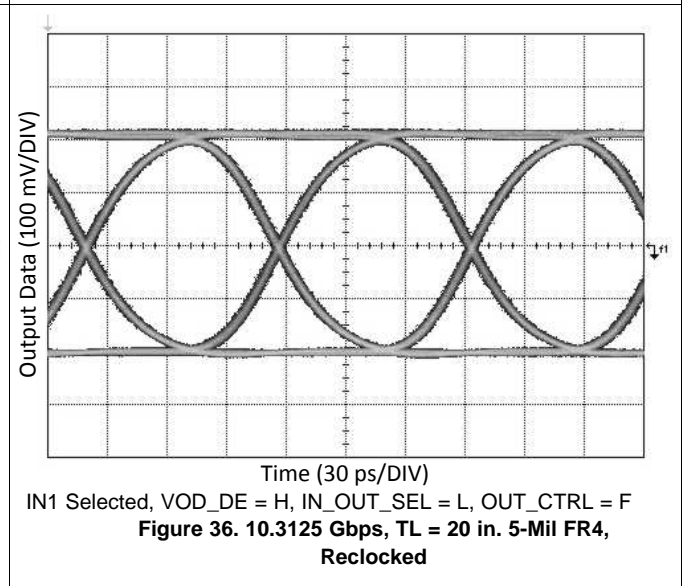
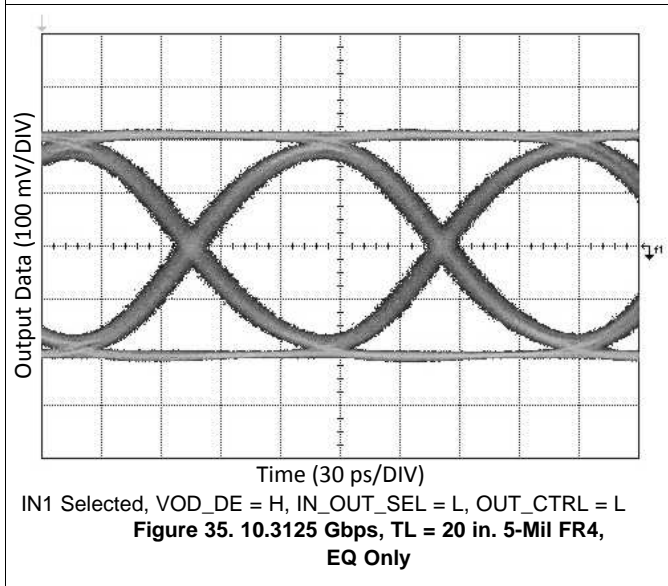
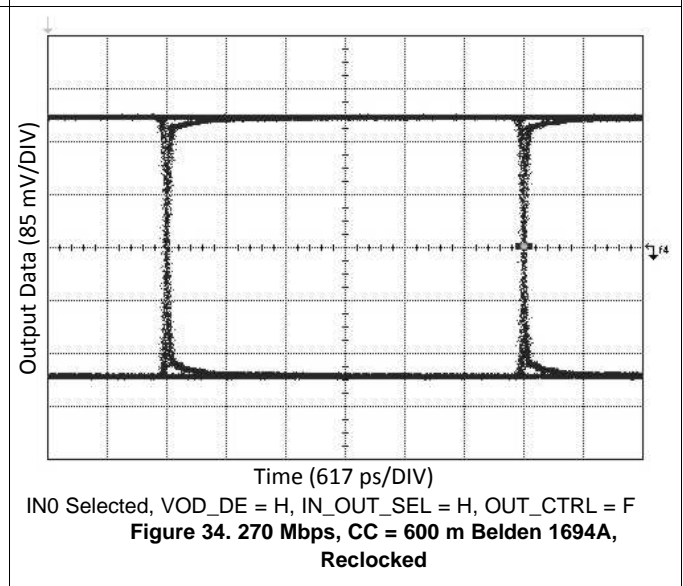
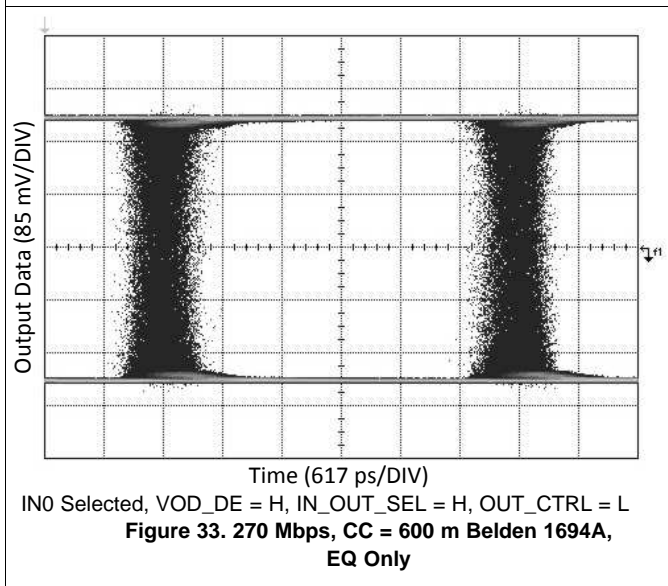
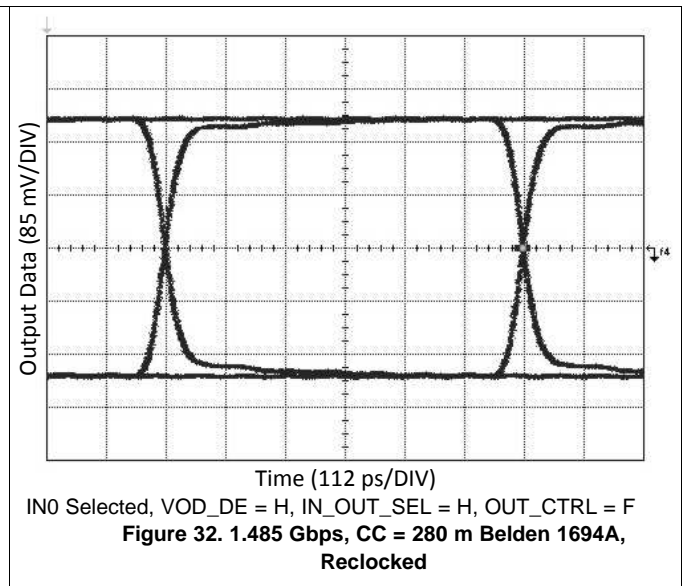
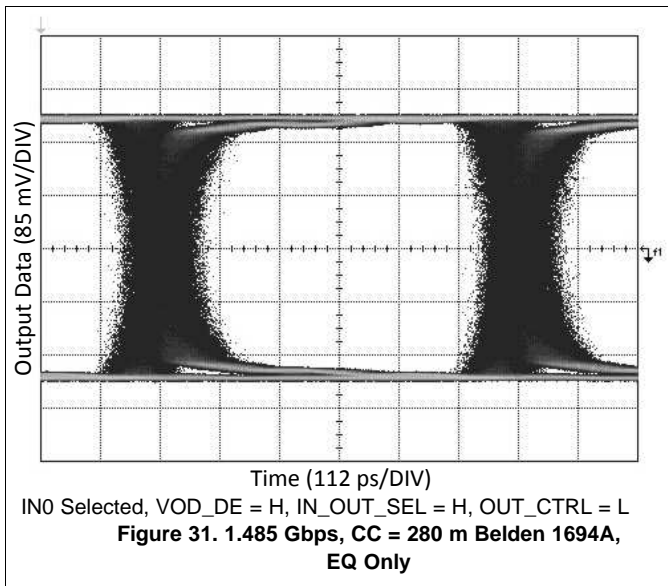

LMH1219

SNLS530D – APRIL 2016 – REVISED JUNE 2018

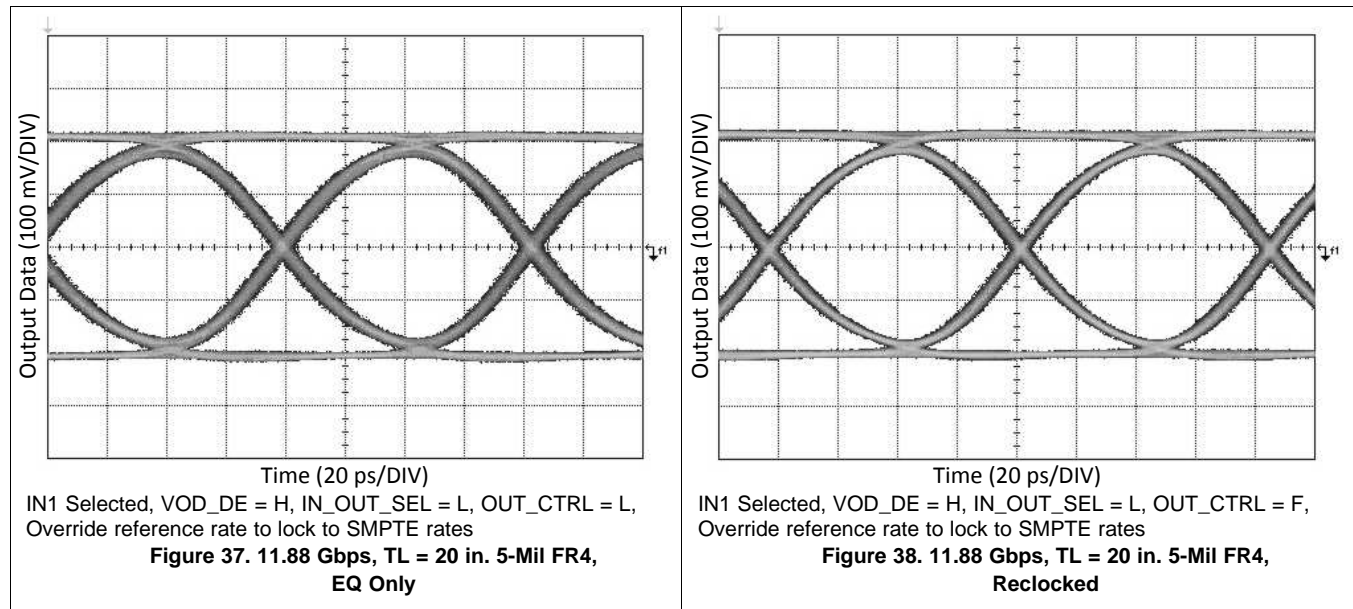
www.ti.com

9 Power Supply Recommendations

The LMH1219 is designed to provide flexibility in supply rails. There are two ways to power the LMH1219:

- **Single Supply Mode (2.5 V):** This mode offers ease of use, with the internal circuitry receiving power from the on-chip 1.8 V regulator. In this mode, 2.5 V is applied to VDD_CDR, VIN, and VDDIO. See [Figure 39](#) for more details.
- **Dual Supply Mode (2.5 V and 1.8 V):** This mode provides lower power consumption. In this mode, 1.8 V is connected to both VIN and VDD_LDO. VDD_CDR, and VDDIO are powered from a 2.5 V supply. See [Figure 40](#) for more details.
- When Dual Supply Mode is used, the 2.5 V supply for VDD_CDR and VDDIO should be powered *before or at the same time* as the 1.8 V supply that powers VIN and VDD_LDO.

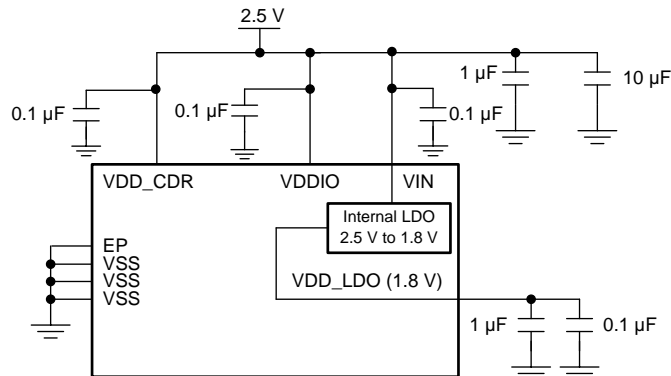

Figure 39. Typical Connection for Single 2.5 V Supply

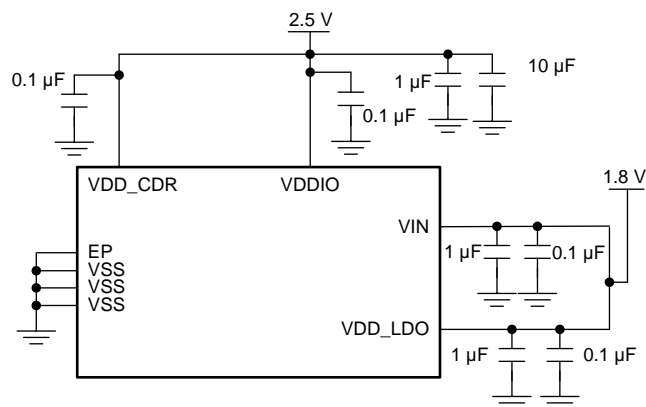

Figure 40. Typical Connection for Dual 2.5 V and 1.8 V Supply

For power supply de-coupling, 0.1- μF surface-mount ceramic capacitors are recommended to be placed close to each VDD_CDR, VIN, VDD_LDO, and VDDIO supply pin to VSS. Larger bulk capacitors (for example, 10 μF and 1 μF) are recommended for VDD_CDR and VIN. Good supply bypassing requires low inductance capacitors. This can be achieved through an array of multiple small body size surface-mount bypass capacitors in order to keep low supply impedance. Better results can be achieved through the use of a buried capacitor formed by a VDD and VSS plane separated by 2-4 mil dielectric in a printed circuit board.

10 Layout

10.1 PCB Layout Guidelines

The following guidelines are recommended for designing the board layout for the LMH1219:

1. Choose a suitable board stack-up that supports 75- Ω single-ended trace and 100- Ω differential trace routing on the board's top layer. This is typically done with a Layer 2 ground plane reference for the 100- Ω

LMH1219

SNLS530D – APRIL 2016 – REVISED JUNE 2018

www.ti.com**PCB Layout Guidelines (continued)**

differential traces and a second ground plane at Layer 3 reference for the 75- Ω single end traces.

2. Use single-ended uncoupled trace designed with 75- Ω impedance for signal routing to IN0+ and IN0-. The trace width is typically 8-10 mil reference to a ground plane at Layer 3.
3. Place anti-pad (ground relief) on the power and ground planes directly under the 4.7- μ F AC coupling capacitor and IC landing pads to minimize parasitic capacitance. The size of the anti-pad depends on the board stack-up and can be determined by a 3-dimension electromagnetic simulation tool.
4. Use a well-designed BNC footprint to ensure the BNC's signal landing pad achieves 75- Ω characteristic impedance. BNC suppliers usually provide recommendations on BNC footprint for best results.
5. Keep trace length short between the BNC and IN0+. The trace routing for IN0+ and IN0- should be symmetrical, approximately equal lengths and equal loading.
6. Use coupled differential traces with 100- Ω impedance for signal routing to IN1 \pm , OUT0 \pm and OUT1 \pm . They are usually 5-8 mil trace width reference to a ground plane at Layer 2.
7. The exposed pad EP of the package should be connected to the ground plane through an array of vias. These vias are solder-masked to avoid solder flowing into the plated-through holes during the board manufacturing process.
8. Connect each supply pin (VDD_CDR, VIN, VDDIO, VDD_LDO) to the power or ground planes with a short via. The via is usually placed tangent to the supply pins' landing pads with the shortest trace possible.
9. Power supply bypass capacitors should be placed close to the supply pins. They are commonly placed at the bottom layer and share the ground of the EP.

10.2 Layout Example

The following example demonstrates the high speed signal trace routing to the LMH1219.

1. BNC footprint and anti-pad: Consult BNC manufacturer for proper size.
2. Anti-pad under passive components.
3. 75- Ω single ended trace. Trace width should be similar to that of the IC landing pad (10 mil).
4. 100- Ω coupled trace.
5. Vias with solder mask.

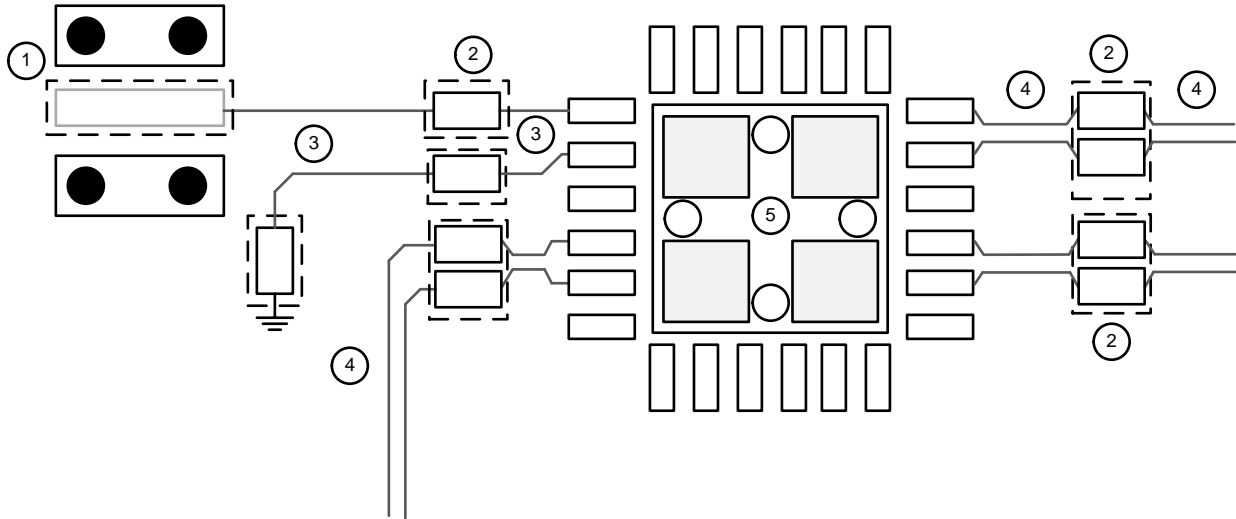

Figure 41. LMH1219 PCB Layout Example

LMH1219

SNLS530D – APRIL 2016 – REVISED JUNE 2018

www.ti.com

11 Device and Documentation Support

11.1 Receiving Notification of Documentation Updates

To receive notification of documentation updates, navigate to the device product folder on ti.com. In the upper right corner, click on *Alert me* to register and receive a weekly digest of any product information that has changed. For change details, review the revision history included in any revised document.

11.2 Community Resources

The following links connect to TI community resources. Linked contents are provided "AS IS" by the respective contributors. They do not constitute TI specifications and do not necessarily reflect TI's views; see TI's [Terms of Use](#).

TI E2E™ Online Community *TI's Engineer-to-Engineer (E2E) Community*. Created to foster collaboration among engineers. At e2e.ti.com, you can ask questions, share knowledge, explore ideas and help solve problems with fellow engineers.

Design Support *TI's Design Support* Quickly find helpful E2E forums along with design support tools and contact information for technical support.

11.3 Trademarks

E2E is a trademark of Texas Instruments.
All other trademarks are the property of their respective owners.

11.4 Electrostatic Discharge Caution



This integrated circuit can be damaged by ESD. Texas Instruments recommends that all integrated circuits be handled with appropriate precautions. Failure to observe proper handling and installation procedures can cause damage.

ESD damage can range from subtle performance degradation to complete device failure. Precision integrated circuits may be more susceptible to damage because very small parametric changes could cause the device not to meet its published specifications.

11.5 Glossary

[SLYZ022](#) — *TI Glossary*.

This glossary lists and explains terms, acronyms, and definitions.

12 Mechanical, Packaging, and Orderable Information

The following pages include mechanical, packaging, and orderable information. This information is the most current data available for the designated devices. This data is subject to change without notice and revision of this document. For browser-based versions of this data sheet, refer to the left-hand navigation.

PACKAGING INFORMATION

Orderable part number	Status (1)	Material type (2)	Package Pins	Package qty Carrier	RoHS (3)	Lead finish/ Ball material (4)	MSL rating/ Peak reflow (5)	Op temp (°C)	Part marking (6)
LMH1219RTWR	Active	Production	WQFN (RTW) 24	3000 LARGE T&R	Yes	SN	Level-3-260C-168 HR	-40 to 85	L1219A2
LMH1219RTWR.A	Active	Production	WQFN (RTW) 24	3000 LARGE T&R	Yes	SN	Level-3-260C-168 HR	-40 to 85	L1219A2
LMH1219RTWR.B	Active	Production	WQFN (RTW) 24	3000 LARGE T&R	Yes	SN	Level-3-260C-168 HR	-40 to 85	L1219A2
LMH1219RTWT	Active	Production	WQFN (RTW) 24	250 SMALL T&R	Yes	SN	Level-3-260C-168 HR	-40 to 85	L1219A2
LMH1219RTWT.A	Active	Production	WQFN (RTW) 24	250 SMALL T&R	Yes	SN	Level-3-260C-168 HR	-40 to 85	L1219A2
LMH1219RTWT.B	Active	Production	WQFN (RTW) 24	250 SMALL T&R	Yes	SN	Level-3-260C-168 HR	-40 to 85	L1219A2

⁽¹⁾ **Status:** For more details on status, see our [product life cycle](#).

⁽²⁾ **Material type:** When designated, preproduction parts are prototypes/experimental devices, and are not yet approved or released for full production. Testing and final process, including without limitation quality assurance, reliability performance testing, and/or process qualification, may not yet be complete, and this item is subject to further changes or possible discontinuation. If available for ordering, purchases will be subject to an additional waiver at checkout, and are intended for early internal evaluation purposes only. These items are sold without warranties of any kind.

⁽³⁾ **RoHS values:** Yes, No, RoHS Exempt. See the [TI RoHS Statement](#) for additional information and value definition.

⁽⁴⁾ **Lead finish/Ball material:** Parts may have multiple material finish options. Finish options are separated by a vertical ruled line. Lead finish/Ball material values may wrap to two lines if the finish value exceeds the maximum column width.

⁽⁵⁾ **MSL rating/Peak reflow:** The moisture sensitivity level ratings and peak solder (reflow) temperatures. In the event that a part has multiple moisture sensitivity ratings, only the lowest level per JEDEC standards is shown. Refer to the shipping label for the actual reflow temperature that will be used to mount the part to the printed circuit board.

⁽⁶⁾ **Part marking:** There may be an additional marking, which relates to the logo, the lot trace code information, or the environmental category of the part.

Multiple part markings will be inside parentheses. Only one part marking contained in parentheses and separated by a "~" will appear on a part. If a line is indented then it is a continuation of the previous line and the two combined represent the entire part marking for that device.

Important Information and Disclaimer:The information provided on this page represents TI's knowledge and belief as of the date that it is provided. TI bases its knowledge and belief on information provided by third parties, and makes no representation or warranty as to the accuracy of such information. Efforts are underway to better integrate information from third parties. TI has taken and continues to take reasonable steps to provide representative and accurate information but may not have conducted destructive testing or chemical analysis on incoming materials and chemicals. TI and TI suppliers consider certain information to be proprietary, and thus CAS numbers and other limited information may not be available for release.

In no event shall TI's liability arising out of such information exceed the total purchase price of the TI part(s) at issue in this document sold by TI to Customer on an annual basis.

TAPE AND REEL INFORMATION

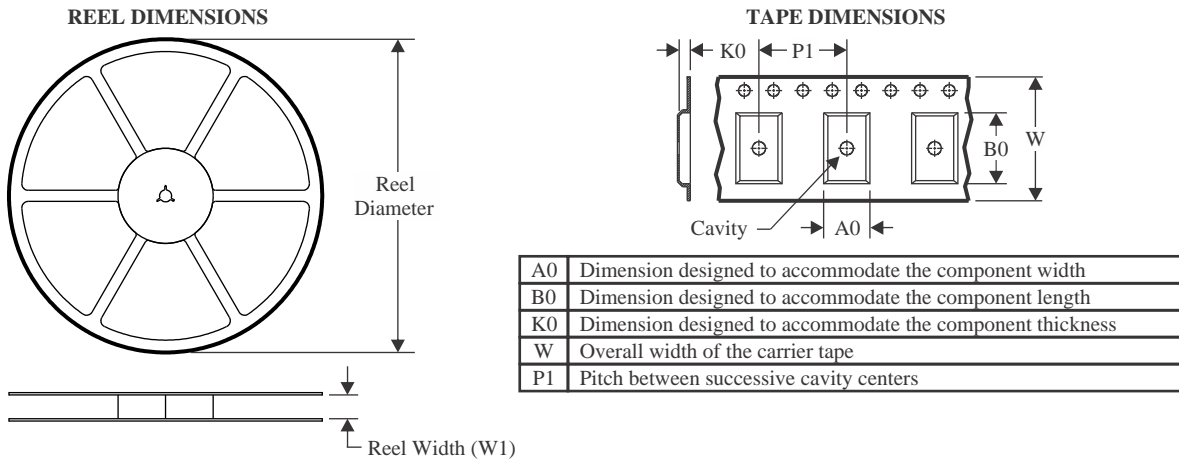

QUADRANT ASSIGNMENTS FOR PIN 1 ORIENTATION IN TAPE

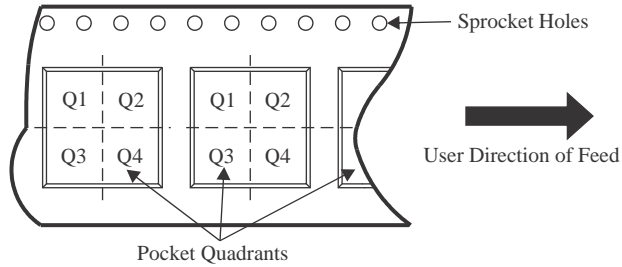

*All dimensions are nominal

Device	Package Type	Package Drawing	Pins	SPQ	Reel Diameter (mm)	Reel Width W1 (mm)	A0 (mm)	B0 (mm)	K0 (mm)	P1 (mm)	W (mm)	Pin1 Quadrant
LMH1219RTWR	WQFN	RTW	24	3000	330.0	12.4	4.3	4.3	1.3	8.0	12.0	Q1
LMH1219RTWT	WQFN	RTW	24	250	177.8	12.4	4.3	4.3	1.3	8.0	12.0	Q1

TAPE AND REEL BOX DIMENSIONS

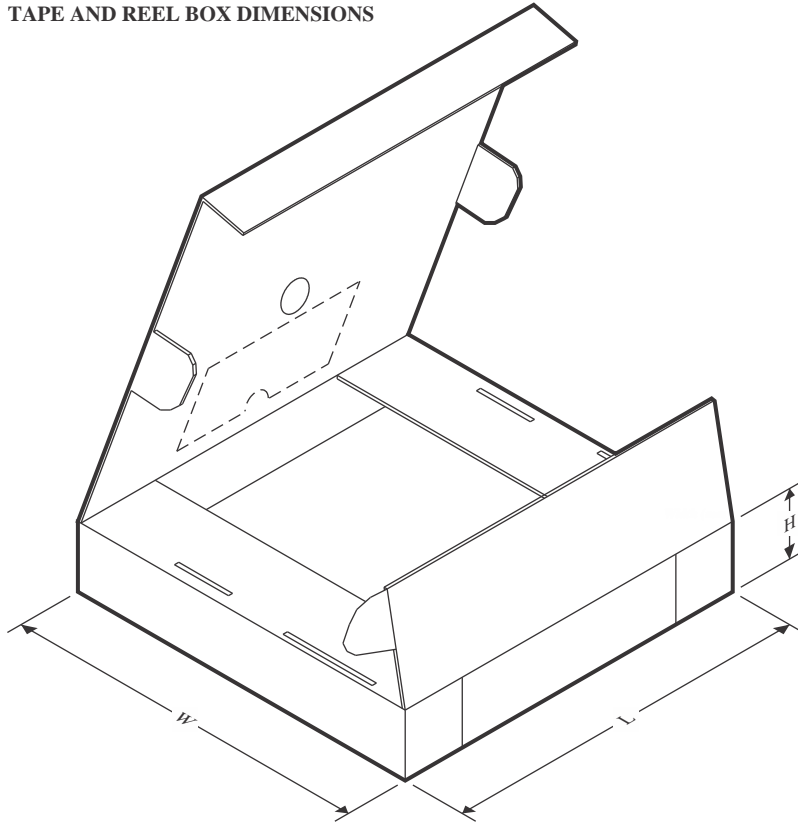

*All dimensions are nominal

Device	Package Type	Package Drawing	Pins	SPQ	Length (mm)	Width (mm)	Height (mm)
LMH1219RTWR	WQFN	RTW	24	3000	356.0	356.0	36.0
LMH1219RTWT	WQFN	RTW	24	250	208.0	191.0	35.0

EXAMPLE BOARD LAYOUT

RTW0024A

WQFN - 0.8 mm max height

PLASTIC QUAD FLATPACK - NO LEAD

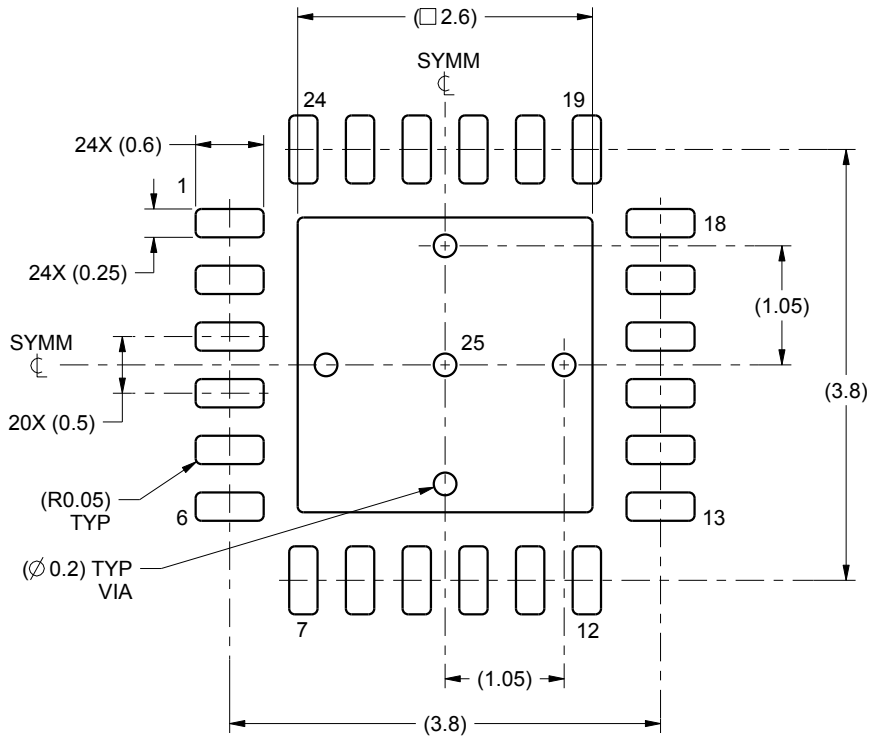

LAND PATTERN EXAMPLE
SCALE:15X

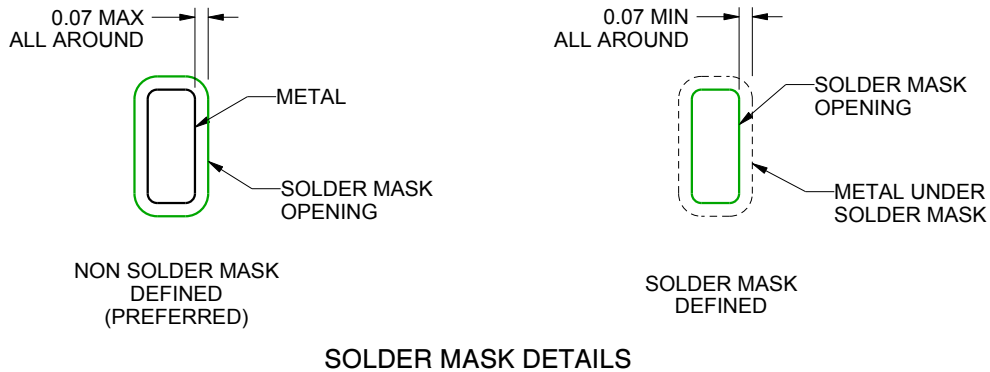

SOLDER MASK DETAILS

4222815/A 03/2016

NOTES: (continued)

4. This package is designed to be soldered to a thermal pad on the board. For more information, see Texas Instruments literature number SLUA271 (www.ti.com/lit/sluea271).

EXAMPLE STENCIL DESIGN

RTW0024A

WQFN - 0.8 mm max height

PLASTIC QUAD FLATPACK - NO LEAD

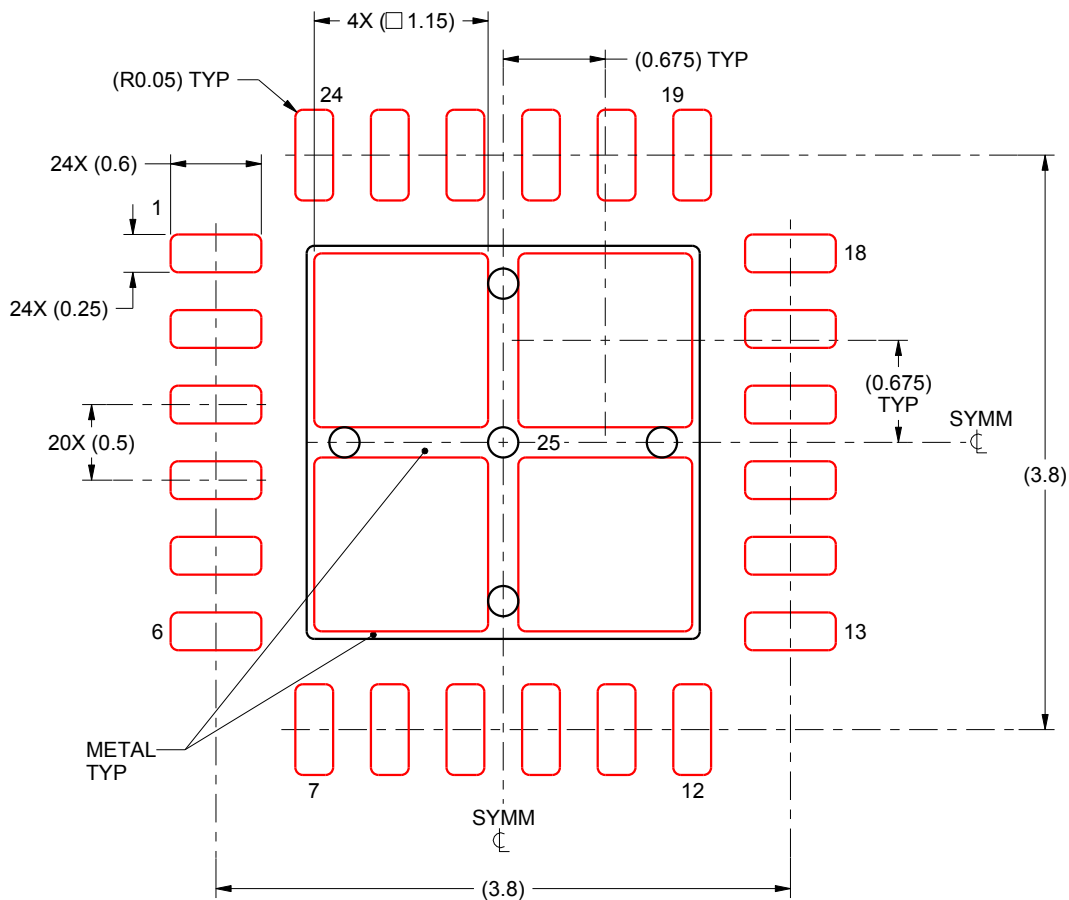

SOLDER PASTE EXAMPLE
 BASED ON 0.125 mm THICK STENCIL

EXPOSED PAD 25:
 78% PRINTED SOLDER COVERAGE BY AREA UNDER PACKAGE
 SCALE:20X

4222815/A 03/2016

NOTES: (continued)

5. Laser cutting apertures with trapezoidal walls and rounded corners may offer better paste release. IPC-7525 may have alternate design recommendations.

IMPORTANT NOTICE AND DISCLAIMER

TI PROVIDES TECHNICAL AND RELIABILITY DATA (INCLUDING DATASHEETS), DESIGN RESOURCES (INCLUDING REFERENCE DESIGNS), APPLICATION OR OTHER DESIGN ADVICE, WEB TOOLS, SAFETY INFORMATION, AND OTHER RESOURCES "AS IS" AND WITH ALL FAULTS, AND DISCLAIMS ALL WARRANTIES, EXPRESS AND IMPLIED, INCLUDING WITHOUT LIMITATION ANY IMPLIED WARRANTIES OF MERCHANTABILITY, FITNESS FOR A PARTICULAR PURPOSE OR NON-INFRINGEMENT OF THIRD PARTY INTELLECTUAL PROPERTY RIGHTS.

These resources are intended for skilled developers designing with TI products. You are solely responsible for (1) selecting the appropriate TI products for your application, (2) designing, validating and testing your application, and (3) ensuring your application meets applicable standards, and any other safety, security, regulatory or other requirements.

These resources are subject to change without notice. TI grants you permission to use these resources only for development of an application that uses the TI products described in the resource. Other reproduction and display of these resources is prohibited. No license is granted to any other TI intellectual property right or to any third party intellectual property right. TI disclaims responsibility for, and you fully indemnify TI and its representatives against any claims, damages, costs, losses, and liabilities arising out of your use of these resources.

TI's products are provided subject to [TI's Terms of Sale](#), [TI's General Quality Guidelines](#), or other applicable terms available either on [ti.com](#) or provided in conjunction with such TI products. TI's provision of these resources does not expand or otherwise alter TI's applicable warranties or warranty disclaimers for TI products. Unless TI explicitly designates a product as custom or customer-specified, TI products are standard, catalog, general purpose devices.

TI objects to and rejects any additional or different terms you may propose.

Copyright © 2025, Texas Instruments Incorporated

Last updated 10/2025

OUR CERTIFICATE

DiGi provide top-quality products and perfect service for customer worldwide through standardization, technological innovation and continuous improvement. DiGi through third-party certification, we strictly control the quality of products and services. Welcome your RFQ to

Email: Info@DiGi-Electronics.com



Tel: +00 852-30501935

RFQ Email: Info@DiGi-Electronics.com

DiGi is a global authorized distributor of electronic components.