

# MUX506IPWR Datasheet

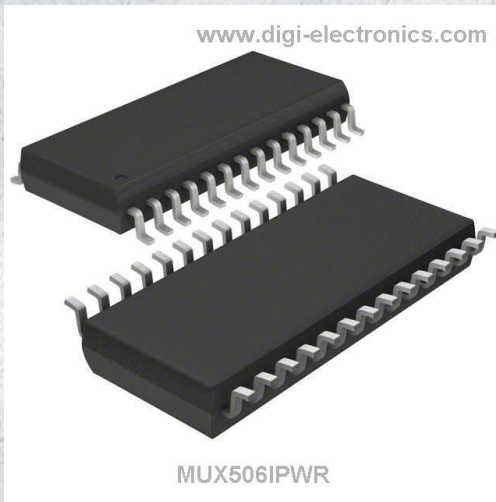

<https://www.DiGi-Electronics.com>

|                              |  |
|------------------------------|--|
| DiGi Electronics Part Number | MUX506IPWR-DG                            |
| Manufacturer                 | <a href="#">Texas Instruments</a>        |
| Manufacturer Product Number  | MUX506IPWR                               |
| Description                  | IC MUX 16:1 2000HM 28TSSOP               |
| Detailed Description         | 1 Circuit IC Switch 16:1 2000hm 28-TSSOP |



Tel: +00 852-30501935

RFQ Email: [Info@DiGi-Electronics.com](mailto:Info@DiGi-Electronics.com)

DiGi is a global authorized distributor of electronic components.

## Purchase and inquiry

Manufacturer Product Number:

MUX506IPWR

Series:

-

Switch Circuit:

-

Number of Circuits:

1

Channel-to-Channel Matching ( $\Delta R_{on}$ ):

60 $\Omega$

Voltage - Supply, Dual ( $V_{\pm}$ ):

$\pm 5V \sim 18V$

-3db Bandwidth:

-

Channel Capacitance ( $C_{S(off)}$ ,  $C_{D(off)}$ ):

3pF, 12.2pF

Crosstalk:

-100dB @ 1MHz

Mounting Type:

Surface Mount

Supplier Device Package:

28-TSSOP

Manufacturer:

Texas Instruments

Product Status:

Active

Multiplexer/Demultiplexer Circuit:

16:1

On-State Resistance (Max):

2000 $\Omega$

Voltage - Supply, Single ( $V_{+}$ ):

10V ~ 36V

Switch Time ( $T_{on}$ ,  $T_{off}$ ) (Max):

136ns, 78ns

Charge Injection:

0.31pC

Current - Leakage ( $I_{S(off)}$ ) (Max):

1nA

Operating Temperature:

-40°C ~ 125°C (TA)

Package / Case:

28-TSSOP (0.173", 4.40mm Width)

Base Product Number:

MUX506

## Environmental & Export classification

RoHS Status:

ROHS3 Compliant

REACH Status:

REACH Unaffected

HTSUS:

8542.39.0001

Moisture Sensitivity Level (MSL):

3 (168 Hours)

ECCN:

EAR99

# MUX50x 36-V, Low-Capacitance, Low-Leakage-Current, Precision Analog Multiplexers

## 1 Features

- Low On-Capacitance
  - MUX506: 13.5 pF
  - MUX507: 8.7 pF
- Low Input Leakage: 1 pA
- Low Charge Injection: 0.31 pC
- Rail-to-Rail Operation
- Wide Supply Range:  $\pm 5$  V to  $\pm 18$  V, 10 V to 36 V
- Low On-Resistance: 125  $\Omega$
- Transition Time: 97 ns
- Break-Before-Make Switching Action
- EN Pin Connectable to  $V_{DD}$
- Logic Levels: 2 V to  $V_{DD}$
- Low Supply Current: 45  $\mu$ A
- ESD Protection HBM: 2000 V
- Industry-Standard TSSOP/ SOIC Package

## 2 Applications

- Factory Automation and Industrial Process Control
- Programmable Logic Controllers (PLC)
- Analog Input Modules
- ATE Test Equipment
- Digital Multimeters
- Battery Monitoring Systems

## 3 Description

The MUX506 and MUX507 (MUX50x) are modern complementary metal-oxide semiconductor (CMOS) precision analog multiplexers (muxes). The MUX506 offers 16:1 single-ended channels, whereas the MUX507 offers differential 8:1 or dual 8:1 single-ended channels. The MUX506 and MUX507 work equally well with either dual supplies ( $\pm 5$  V to  $\pm 18$  V) or a single supply (10 V to 36 V). These devices also perform well with symmetric supplies (such as  $V_{DD} = 12$  V,  $V_{SS} = -12$  V), and unsymmetric supplies (such as  $V_{DD} = 12$  V,  $V_{SS} = -5$  V). All digital inputs have transistor-transistor logic (TTL) compatible thresholds, providing both TTL and CMOS logic compatibility when operating in the valid supply voltage range.

The MUX507 and MUX507 have very low on- and off-leakage currents, allowing these multiplexers to switch signals from high input impedance sources with minimal error. A low supply current of 45  $\mu$ A enables use in power-sensitive applications.

### Device Information<sup>(1)</sup>

| PART NUMBER | PACKAGE    | BODY SIZE (NOM)   |
|-------------|------------|-------------------|
| MUX506      | TSSOP (28) | 9.70 mm x 6.40 mm |
| MUX507      | SOIC (28)  | 17.9 mm x 7.50 mm |

(1) For all available packages, see the package option addendum at the end of the data sheet.

### Simplified Schematic

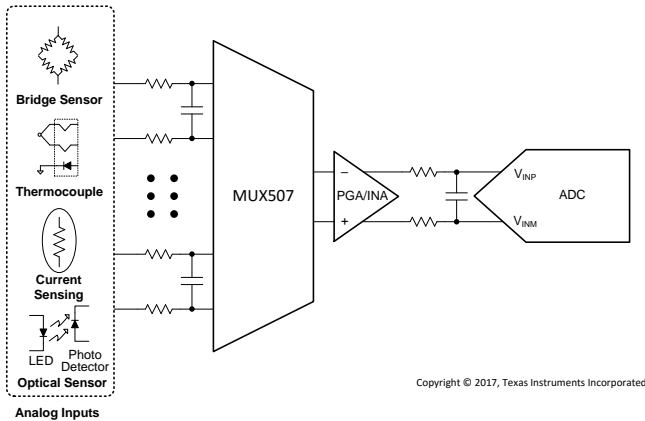

### Leakage Current vs Temperature

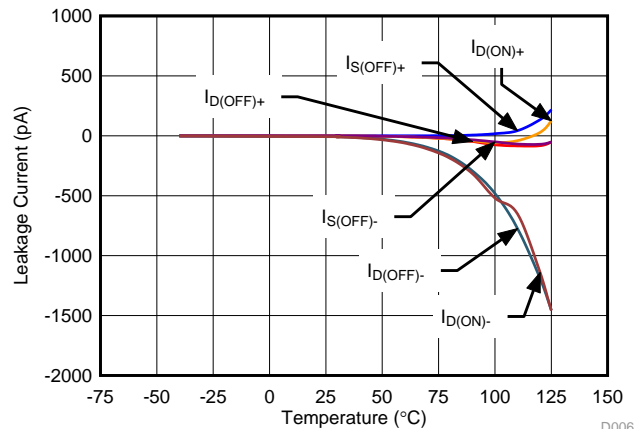

**MUX506, MUX507**

SBAS803A –NOVEMBER 2016–REVISED NOVEMBER 2017

www.ti.com

**Table of Contents**

|   |    |  |    |
|---|----|--|----|
| <b>1 Features</b> .....                             | 1  | 7.11 Bandwidth .....   | 23 |
| <b>2 Applications</b> .....                         | 1  | 7.12 THD + Noise .....   | 23 |
| <b>3 Description</b> .....                          | 1  | <b>8 Detailed Description</b> .....                              | 24 |
| <b>4 Revision History</b> .....                     | 2  | 8.1 Overview .....   | 24 |
| <b>5 Pin Configuration and Functions</b> .....      | 3  | 8.2 Functional Block Diagram .....                               | 24 |
| <b>6 Specifications</b> .....                       | 6  | 8.3 Feature Description .....                                    | 25 |
| 6.1 Absolute Maximum Ratings .....                  | 6  | 8.4 Device Functional Modes .....                                | 27 |
| 6.2 ESD Ratings .....                               | 6  | <b>9 Application and Implementation</b> .....                    | 28 |
| 6.3 Recommended Operating Conditions .....          | 6  | 9.1 Application Information .....                                | 28 |
| 6.4 Thermal Information .....                       | 7  | 9.2 Typical Application .....                                    | 28 |
| 6.5 Electrical Characteristics: Dual Supply .....   | 7  | <b>10 Power Supply Recommendations</b> .....                     | 30 |
| 6.6 Electrical Characteristics: Single Supply ..... | 9  | <b>11 Layout</b> .....   | 31 |
| 6.7 Typical Characteristics .....                   | 11 | 11.1 Layout Guidelines .....                                     | 31 |
| <b>7 Parameter Measurement Information</b> .....    | 16 | 11.2 Layout Example .....  | 31 |
| 7.1 Truth Tables .....                              | 16 | <b>12 Device and Documentation Support</b> .....                 | 33 |
| 7.2 On-Resistance .....                             | 17 | 12.1 Documentation Support .....                                 | 33 |
| 7.3 Off Leakage .....                               | 17 | 12.2 Related Links .....   | 33 |
| 7.4 On-Leakage Current .....                        | 18 | 12.3 Receiving Notification of Documentation Updates .....       | 33 |
| 7.5 Transition Time .....                           | 18 | 12.4 Community Resources .....                                   | 33 |
| 7.6 Break-Before-Make Delay .....                   | 19 | 12.5 Trademarks .....  | 33 |
| 7.7 Turn-On and Turn-Off Time .....                 | 20 | 12.6 Electrostatic Discharge Caution .....                       | 33 |
| 7.8 Charge Injection .....                          | 21 | 12.7 Glossary .....  | 33 |
| 7.9 Off Isolation .....                             | 22 | <b>13 Mechanical, Packaging, and Orderable Information</b> ..... | 34 |
| 7.10 Channel-to-Channel Crosstalk .....             | 22 |  |    |

**4 Revision History**

NOTE: Page numbers for previous revisions may differ from page numbers in the current version.

| <b>Changes from Original (November 2016) to Revision A</b>   | <b>Page</b> |
|--|-------------|
| • Changed Transition Time From: 85 ns To: 97ns (Typ) in the <i>Features</i> list .....   | 1           |
| • Added SOIC packages to <i>Feature</i> and <i>Device Information</i> .....  | 1           |
| • Added the DW (SOIC) package to the <i>Pin Configuration and Functions</i> section .....  | 3           |
| • Added SOIC package to the <i>Thermal Information</i> table .....   | 7           |
| • Changed Transition time Typ value From 85: ns To: 97ns for $\pm 15$ V supplies in the <i>Electrical Characteristics: Dual Supply</i> table .....   | 8           |
| • Added additional specifications for the SOIC packages ( $Q_J$ , Off-isolation, and channel-to-channel crosstalk) for $\pm 15$ V supplies in <i>Electrical Characteristics: Dual Supply</i> ..... | 8           |
| • Changed Transition time Typ value From: 91 To: 102 ns for 12 V supply in the <i>Electrical Characteristics: Single Supply</i> table .....  | 10          |
| • Added additional specifications for the SOIC packages ( $Q_J$ , Off-isolation, and channel-to-channel crosstalk) for 12 V supply in <i>Electrical Characteristics: Single Supply</i> .....       | 10          |
| • Added NOTE to the <i>Application and Implementation</i> section .....  | 28          |

## 5 Pin Configuration and Functions

**MUX506: PW and DW Packages  
28-Pin TSSOP and SOIC  
Top View**

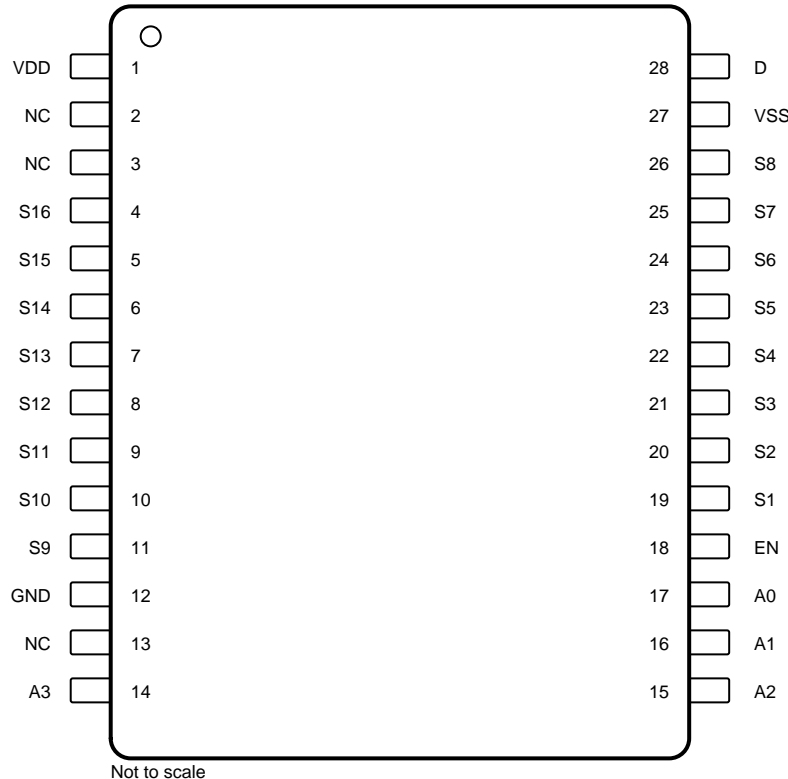

**Pin Functions: MUX506**

| PIN  |          | FUNCTION               | DESCRIPTION   |
|------|----------|------------------------|---|
| NAME | NO.      |                        |   |
| A0   | 17       | Digital input          | Address line 0  |
| A1   | 16       | Digital input          | Address line 1  |
| A2   | 15       | Digital input          | Address line 2  |
| A3   | 14       | Digital input          | Address line 3  |
| D    | 28       | Analog input or output | Drain pin. Can be an input or output.   |
| EN   | 18       | Digital input          | Active high digital input. When this pin is low, all switches are turned off. When this pin is high, the A[3:0] logic inputs determine which switch is turned on. |
| GND  | 12       | Power supply           | Ground (0 V) reference  |
| NC   | 2, 3, 13 | No connect             | Do not connect  |
| S1   | 19       | Analog input or output | Source pin 1. Can be an input or output.  |
| S2   | 20       | Analog input or output | Source pin 2. Can be an input or output.  |
| S3   | 21       | Analog input or output | Source pin 3. Can be an input or output.  |
| S4   | 22       | Analog input or output | Source pin 4. Can be an input or output.  |
| S5   | 23       | Analog input or output | Source pin 5. Can be an input or output.  |
| S6   | 24       | Analog input or output | Source pin 6. Can be an input or output.  |
| S7   | 25       | Analog input or output | Source pin 7. Can be an input or output.  |
| S8   | 26       | Analog input or output | Source pin 8. Can be an input or output.  |
| S9   | 11       | Analog input or output | Source pin 9. Can be an input or output.  |

**MUX506, MUX507**

SBAS803A –NOVEMBER 2016–REVISED NOVEMBER 2017

www.ti.com

**Pin Functions: MUX506 (continued)**

| PIN  |     | FUNCTION               | DESCRIPTION   |
|------|-----|------------------------|---|
| NAME | NO. |                        |   |
| S10  | 10  | Analog input or output | Source pin 10. Can be an input or output.   |
| S11  | 9   | Analog input or output | Source pin 11. Can be an input or output.   |
| S12  | 8   | Analog input or output | Source pin 12. Can be an input or output.   |
| S13  | 7   | Analog input or output | Source pin 13. Can be an input or output.   |
| S14  | 6   | Analog input or output | Source pin 14. Can be an input or output.   |
| S15  | 5   | Analog input or output | Source pin 15. Can be an input or output.   |
| S16  | 4   | Analog input or output | Source pin 16. Can be an input or output.   |
| VDD  | 1   | Power supply           | Positive power supply. This pin is the most positive power-supply potential. For reliable operation, connect a decoupling capacitor ranging from 0.1 $\mu$ F to 10 $\mu$ F between VDD and GND.   |
| VSS  | 27  | Power supply           | Negative power supply. This pin is the most negative power-supply potential. In single-supply applications, this pin can be connected to ground. For reliable operation, connect a decoupling capacitor ranging from 0.1 $\mu$ F to 10 $\mu$ F between VSS and GND. |

**MUX507: PW and DW Package  
28-Pin TSSOP and SOIC  
Top View**

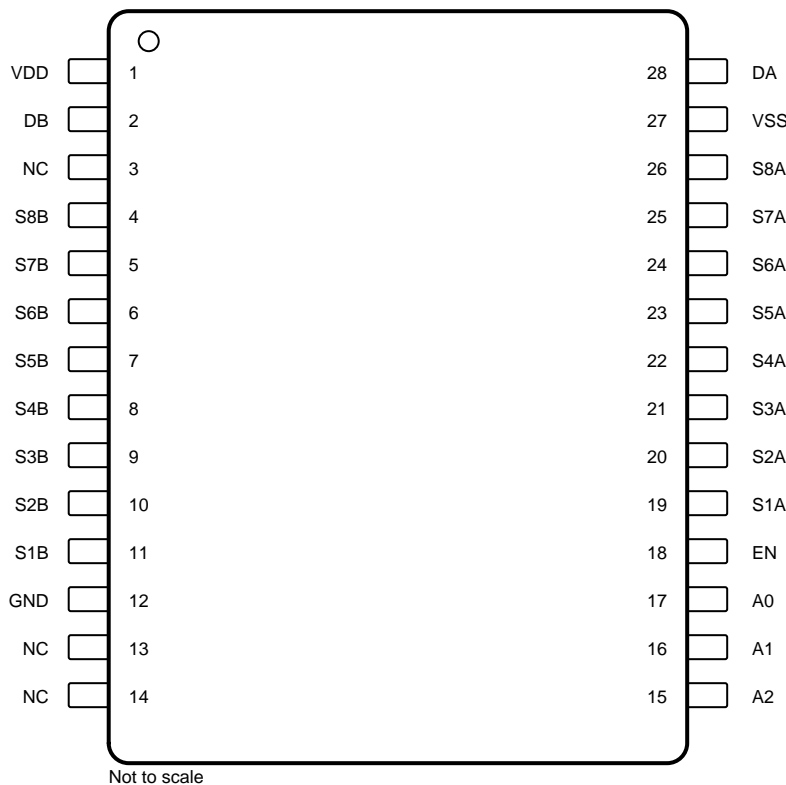

**Pin Functions: MUX507**

| PIN  |     | FUNCTION               | DESCRIPTION                             |
|------|-----|------------------------|---|
| NAME | NO. |                        |   |
| A0   | 17  | Digital input          | Address line 0                          |
| A1   | 16  | Digital input          | Address line 1                          |
| A2   | 15  | Digital input          | Address line 2                          |
| DA   | 28  | Analog input or output | Drain pin A. Can be an input or output. |

**Pin Functions: MUX507 (continued)**

| PIN  |           | FUNCTION               | DESCRIPTION   |
|------|-----------|------------------------|---|
| NAME | NO.       |                        |   |
| DB   | 2         | Analog input or output | Drain pin B. Can be an input or output.   |
| EN   | 18        | Digital input          | Active high digital input. When this pin is low, all switches are turned off. When this pin is high, the A[2:0] logic inputs determine which pair of switches is turned on.   |
| GND  | 12        | Power supply           | Ground (0 V) reference  |
| NC   | 3, 13, 14 | No connect             | Do not connect  |
| S1A  | 19        | Analog input or output | Source pin 1A. Can be an input or output.   |
| S2A  | 20        | Analog input or output | Source pin 2A. Can be an input or output.   |
| S3A  | 21        | Analog input or output | Source pin 3A. Can be an input or output.   |
| S4A  | 22        | Analog input or output | Source pin 4A. Can be an input or output.   |
| S5A  | 23        | Analog input or output | Source pin 5A. Can be an input or output.   |
| S6A  | 24        | Analog input or output | Source pin 6A. Can be an input or output.   |
| S7A  | 25        | Analog input or output | Source pin 7A. Can be an input or output.   |
| S8A  | 26        | Analog input or output | Source pin 8A. Can be an input or output.   |
| S1B  | 11        | Analog input or output | Source pin 1B. Can be an input or output.   |
| S2B  | 10        | Analog input or output | Source pin 2B. Can be an input or output.   |
| S3B  | 9         | Analog input or output | Source pin 3B. Can be an input or output.   |
| S4B  | 8         | Analog input or output | Source pin 4B. Can be an input or output.   |
| S5B  | 7         | Analog input or output | Source pin 5B. Can be an input or output.   |
| S6B  | 6         | Analog input or output | Source pin 6B. Can be an input or output.   |
| S7B  | 5         | Analog input or output | Source pin 7B. Can be an input or output.   |
| S8B  | 4         | Analog input or output | Source pin 8B. Can be an input or output.   |
| VDD  | 1         | Power supply           | Positive power supply. This pin is the most positive power supply potential. For reliable operation, connect a decoupling capacitor ranging from 0.1 $\mu$ F to 10 $\mu$ F between VDD and GND.   |
| VSS  | 27        | Power supply           | Negative power supply. This pin is the most negative power supply potential. In single-supply applications, this pin can be connected to ground. For reliable operation, connect a decoupling capacitor ranging from 0.1 $\mu$ F to 10 $\mu$ F between VSS and GND. |

**MUX506, MUX507**

SBAS803A –NOVEMBER 2016–REVISED NOVEMBER 2017

www.ti.com

**6 Specifications****6.1 Absolute Maximum Ratings**over operating free-air temperature range (unless otherwise noted)<sup>(1)</sup>

|                        |  | MIN               | MAX            | UNIT |   |
|------------------------|--|-------------------|----------------|------|---|
| Voltage                | Supply   | $V_{DD}$          | -0.3           | 40   | V |
|                        |  | $V_{SS}$          | -40            | 0.3  |   |
|                        |  | $V_{DD} - V_{SS}$ |                | 40   |   |
|                        | Digital pins <sup>(2)</sup> : EN, A0, A1, A2, A3     | $V_{SS} - 0.3$    | $V_{DD} + 0.3$ |      |   |
|                        | Analog pins <sup>(2)</sup> : Sx, SxA, SxB, D, DA, DB | $V_{SS} - 2$      | $V_{DD} + 2$   |      |   |
| Current <sup>(3)</sup> |  | -30               | 30             | mA   |   |
| Temperature            | Operating, $T_A$                                     | -55               | 150            | °C   |   |
|                        | Junction, $T_J$                                      |                   | 150            |      |   |
|                        | Storage, $T_{stg}$                                   | -65               | 150            |      |   |

(1) Stresses beyond those listed under *Absolute Maximum Ratings* may cause permanent damage to the device. These are stress ratings only, which do not imply functional operation of the device at these or any other conditions beyond those indicated under *Recommended Operating Conditions*. Exposure to absolute-maximum-rated conditions for extended periods may affect device reliability.

(2) Voltage limits are valid if current is limited to  $\pm 30$  mA.

(3) Only one pin at a time.

**6.2 ESD Ratings**

|             |                         | VALUE  | UNIT |   |
|-------------|-------------------------|--|------|---|
| $V_{(ESD)}$ | Electrostatic discharge | Human-body model (HBM), per ANSI/ESDA/JEDEC JS-001 <sup>(1)</sup>              | 2000 | V |
|             |                         | Charged-device model (CDM), per JEDEC specification JESD22-C101 <sup>(2)</sup> | 500  |   |

(1) JEDEC document JEP155 states that 500-V HBM allows safe manufacturing with a standard ESD control process.

(2) JEDEC document JEP157 states that 250-V CDM allows safe manufacturing with a standard ESD control process.

**6.3 Recommended Operating Conditions**

|                         |  | MIN           | NOM | MAX      | UNIT |
|-------------------------|--|---------------|-----|----------|------|
| $V_{DD}$ <sup>(1)</sup> | Positive power-supply voltage                | Dual supply   | 5   | 18       | V    |
|                         |  | Single supply | 10  | 36       |      |
| $V_{SS}$ <sup>(2)</sup> | Negative power-supply voltage (dual supply)  | -5            |     | -18      | V    |
| $V_{DD} - V_{SS}$       | Supply voltage                               | 10            |     | 36       | V    |
| $V_S$                   | Source pins voltage <sup>(3)</sup>           | $V_{SS}$      |     | $V_{DD}$ | V    |
| $V_D$                   | Drain pins voltage                           | $V_{SS}$      |     | $V_{DD}$ | V    |
| $V_{EN}$                | Enable pin voltage                           | $V_{SS}$      |     | $V_{DD}$ | V    |
| $V_A$                   | Address pins voltage                         | $V_{SS}$      |     | $V_{DD}$ | V    |
| $I_{CH}$                | Channel current ( $T_A = 25^\circ\text{C}$ ) | -25           |     | 25       | mA   |
| $T_A$                   | Operating temperature                        | -40           |     | 125      | °C   |

(1) When  $V_{SS} = 0$  V,  $V_{DD}$  can range from 10 V to 36 V.

(2)  $V_{DD}$  and  $V_{SS}$  can be any value as long as  $10 \text{ V} \leq (V_{DD} - V_{SS}) \leq 36 \text{ V}$ .

(3)  $V_S$  is the voltage on all the S pins.

## 6.4 Thermal Information

| THERMAL METRIC <sup>(1)</sup> |  | MUX50x     |           | UNIT |
|-------------------------------|--|------------|-----------|------|
|                               |  | PW (TSSOP) | DW (SOIC) |      |
|                               |  | 28 PINS    | 28 PINS   |      |
| $R_{\theta JA}$               | Junction-to-ambient thermal resistance       | 79.8       | 53.6      | °C/W |
| $R_{\theta JC(top)}$          | Junction-to-case (top) thermal resistance    | 24.0       | 30.1      | °C/W |
| $R_{\theta JB}$               | Junction-to-board thermal resistance         | 37.6       | 28.5      | °C/W |
| $\psi_{JT}$                   | Junction-to-top characterization parameter   | 1.2        | 9.0       | °C/W |
| $\psi_{JB}$                   | Junction-to-board characterization parameter | 37.1       | 28.4      | °C/W |
| $R_{\theta JC(bot)}$          | Junction-to-case (bottom) thermal resistance | N/A        | N/A       | °C/W |

(1) For more information about traditional and new thermal metrics, see the [Semiconductor and IC Package Thermal Metrics](#) application report.

## 6.5 Electrical Characteristics: Dual Supply

at  $T_A = 25^\circ\text{C}$ ,  $V_{DD} = 15\text{ V}$ , and  $V_{SS} = -15\text{ V}$  (unless otherwise noted)

| PARAMETER            | TEST CONDITIONS  | MIN   | TYP  | MAX      | UNIT                    |    |
|----------------------|--|---|------|----------|-------------------------|----|
| <b>ANALOG SWITCH</b> |  |   |      |          |                         |    |
| Analog signal range  | $T_A = -40^\circ\text{C}$ to $+125^\circ\text{C}$  | $V_{SS}$  |      | $V_{DD}$ | V                       |    |
| $R_{ON}$             | On-resistance<br>$V_S = 0\text{ V}$ , $I_S = -1\text{ mA}$   |   | 125  | 170      | $\Omega$                |    |
|                      |  |   | 145  | 200      |                         |    |
|                      | $V_S = \pm 10\text{ V}$ , $I_S = -1\text{ mA}$   | $T_A = -40^\circ\text{C}$ to $+85^\circ\text{C}$  |      | 230      |                         |    |
|                      |  | $T_A = -40^\circ\text{C}$ to $+125^\circ\text{C}$ |      | 250      |                         |    |
| $\Delta R_{ON}$      | On-resistance mismatch between channels<br>$V_S = \pm 10\text{ V}$ , $I_S = -1\text{ mA}$                              |   | 6    | 9        | $\Omega$                |    |
|                      |  | $T_A = -40^\circ\text{C}$ to $+85^\circ\text{C}$  |      | 14       |                         |    |
|                      |  | $T_A = -40^\circ\text{C}$ to $+125^\circ\text{C}$ |      | 16       |                         |    |
| $R_{FLAT}$           | On-resistance flatness<br>$V_S = 10\text{ V}$ , $0\text{ V}$ , $-10\text{ V}$  |   | 20   | 45       | $\Omega$                |    |
|                      |  | $T_A = -40^\circ\text{C}$ to $+85^\circ\text{C}$  |      | 53       |                         |    |
|                      |  | $T_A = -40^\circ\text{C}$ to $+125^\circ\text{C}$ |      | 58       |                         |    |
| On-resistance drift  | $V_S = 0\text{ V}$   |   | 0.62 |          | $\Omega/^\circ\text{C}$ |    |
| $I_{S(OFF)}$         | Input leakage current<br>Switch state is off,<br>$V_S = \pm 10\text{ V}$ , $V_D = \pm 10\text{ V}$ <sup>(1)</sup>      |   | -1   | -0.001   | 1                       | nA |
|                      |  | $T_A = -40^\circ\text{C}$ to $+85^\circ\text{C}$  |      | -10      | 10                      |    |
|                      |  | $T_A = -40^\circ\text{C}$ to $+125^\circ\text{C}$ |      | -25      | 25                      |    |
| $I_{D(OFF)}$         | Output off-leakage current<br>Switch state is off,<br>$V_S = \pm 10\text{ V}$ , $V_D = \pm 10\text{ V}$ <sup>(1)</sup> |   | -1   | -0.01    | 1                       | nA |
|                      |  | $T_A = -40^\circ\text{C}$ to $+85^\circ\text{C}$  |      | -10      | 10                      |    |
|                      |  | $T_A = -40^\circ\text{C}$ to $+125^\circ\text{C}$ |      | -25      | 25                      |    |
| $I_{D(ON)}$          | Output on-leakage current<br>Switch state is on,<br>$V_D = \pm 10\text{ V}$ , $V_S = \text{floating}$                  |   | -1   | -0.01    | 1                       | nA |
|                      |  | $T_A = -40^\circ\text{C}$ to $+85^\circ\text{C}$  |      | -10      | 10                      |    |
|                      |  | $T_A = -40^\circ\text{C}$ to $+125^\circ\text{C}$ |      | -50      | 50                      |    |
| <b>LOGIC INPUT</b>   |  |   |      |          |                         |    |
| $V_{IH}$             | Logic voltage high   | 2   |      |          | V                       |    |
| $V_{IL}$             | Logic voltage low  |   |      | 0.8      | V                       |    |
| $I_D$                | Input current  |   |      | 0.1      | $\mu\text{A}$           |    |

(1) When  $V_S$  is positive,  $V_D$  is negative, and vice versa.

**MUX506, MUX507**

SBAS803A –NOVEMBER 2016–REVISED NOVEMBER 2017

www.ti.com

**Electrical Characteristics: Dual Supply (continued)**at  $T_A = 25^\circ\text{C}$ ,  $V_{DD} = 15\text{ V}$ , and  $V_{SS} = -15\text{ V}$  (unless otherwise noted)

| PARAMETER                            |  | TEST CONDITIONS   |  | MIN           | TYP  | MAX       | UNIT          |
|--------------------------------------|--|---|--|---------------|------|-----------|---------------|
| <b>SWITCH DYNAMICS<sup>(2)</sup></b> |  |   |  |               |      |           |               |
| $t_{ON}$                             | Enable turn-on time  | $V_S = \pm 10\text{ V}$ , $R_L = 300\ \Omega$ ,<br>$C_L = 35\text{ pF}$   | $T_A = -40^\circ\text{C to } +85^\circ\text{C}$  |               | 82   | 136       | ns            |
|                                      |  |   | $T_A = -40^\circ\text{C to } +125^\circ\text{C}$ |               |      | 145       |               |
|                                      |  |   |  |               |      | 151       |               |
| $t_{OFF}$                            | Enable turn-off time   | $V_S = \pm 10\text{ V}$ , $R_L = 300\ \Omega$ ,<br>$C_L = 35\text{ pF}$   | $T_A = -40^\circ\text{C to } +85^\circ\text{C}$  |               | 63   | 78        | ns            |
|                                      |  |   | $T_A = -40^\circ\text{C to } +125^\circ\text{C}$ |               |      | 89        |               |
|                                      |  |   |  |               |      | 97        |               |
| $t_t$                                | Transition time  | $V_S = 10\text{ V}$ , $R_L = 300\ \Omega$ ,<br>$C_L = 35\text{ pF}$   | $T_A = -40^\circ\text{C to } +85^\circ\text{C}$  |               | 97   | 143       | ns            |
|                                      |  |   | $T_A = -40^\circ\text{C to } +125^\circ\text{C}$ |               |      | 151       |               |
|                                      |  |   |  |               |      | 157       |               |
| $t_{BBM}$                            | Break-before-make time delay   | $V_S = 10\text{ V}$ , $R_L = 300\ \Omega$ , $C_L = 35\text{ pF}$ , $T_A = -40^\circ\text{C to } +125^\circ\text{C}$ |  | 30            | 54   |           | ns            |
| $Q_J$                                | Charge injection   | $C_L = 1\text{ nF}$ , $R_S = 0\ \Omega$   | $V_S = 0\text{ V}$                               | TSSOP package |      | 0.31      | pC            |
|                                      |  |   |  | SOIC package  |      | 0.67      |               |
|                                      |  |   | $V_S = -15\text{ V to } +15\text{ V}$            | TSSOP package |      | $\pm 0.9$ |               |
|                                      |  |   |  | SOIC package  |      | $\pm 1.1$ |               |
| Off-isolation                        | Nonadjacent channel to D, DA, DB   | $R_L = 50\ \Omega$ , $V_S = 1\text{ V}_{RMS}$ ,<br>$f = 1\text{ MHz}$   | Adjacent channel to D, DA, DB                    | TSSOP package |      | -98       | dB            |
|                                      |  |   |  | SOIC package  |      | -94       |               |
|                                      |  |   |  | TSSOP package |      | -94       |               |
|                                      |  |   |  | SOIC package  |      | -88       |               |
| Channel-to-channel crosstalk         | Nonadjacent channels   | $R_L = 50\ \Omega$ , $V_S = 1\text{ V}_{RMS}$ ,<br>$f = 1\text{ MHz}$   | Adjacent channels                                | TSSOP package |      | -100      | dB            |
|                                      |  |   |  | SOIC package  |      | -96       |               |
|                                      |  |   |  | TSSOP package |      | -88       |               |
|                                      |  |   |  | SOIC package  |      | -83       |               |
| $C_{S(OFF)}$                         | Input off-capacitance  | $f = 1\text{ MHz}$ , $V_S = 0\text{ V}$   |  |               | 2.1  | 3         | pF            |
| $C_{D(OFF)}$                         | Output off-capacitance   | $f = 1\text{ MHz}$ , $V_S = 0\text{ V}$   | MUX506   |               | 11.1 | 12.2      | pF            |
|                                      |  |   | MUX507   |               | 6.4  | 7.5       |               |
| $C_{S(ON)}$ ,<br>$C_{D(ON)}$         | Output on-capacitance  | $f = 1\text{ MHz}$ , $V_S = 0\text{ V}$   | MUX506   |               | 13.5 | 15        | pF            |
|                                      |  |   | MUX507   |               | 8.7  | 10.2      |               |
| <b>POWER SUPPLY</b>                  |  |   |  |               |      |           |               |
| $V_{DD}$ supply current              | All $V_A = 0\text{ V}$ or $3.3\text{ V}$ ,<br>$V_S = 0\text{ V}$ , $V_{EN} = 3.3\text{ V}$ , | $T_A = -40^\circ\text{C to } +85^\circ\text{C}$   |  |               | 45   | 59        | $\mu\text{A}$ |
|                                      |  |   | $T_A = -40^\circ\text{C to } +125^\circ\text{C}$ |               |      | 62        |               |
|                                      |  |   |  |               |      | 85        |               |
| $V_{SS}$ supply current              | All $V_A = 0\text{ V}$ or $3.3\text{ V}$ ,<br>$V_S = 0\text{ V}$ , $V_{EN} = 3.3\text{ V}$ , | $T_A = -40^\circ\text{C to } +85^\circ\text{C}$   |  |               | 26   | 34        | $\mu\text{A}$ |
|                                      |  |   | $T_A = -40^\circ\text{C to } +125^\circ\text{C}$ |               |      | 37        |               |
|                                      |  |   |  |               |      | 58        |               |

(2) Specified by design; not subject to production testing.

## 6.6 Electrical Characteristics: Single Supply

 at  $T_A = 25^\circ\text{C}$ ,  $V_{DD} = 12\text{ V}$ , and  $V_{SS} = 0\text{ V}$  (unless otherwise noted)

| PARAMETER            |                            | TEST CONDITIONS  |   | MIN      | TYP   | MAX      | UNIT                    |
|----------------------|----------------------------|--|---|----------|-------|----------|-------------------------|
| <b>ANALOG SWITCH</b> |                            |  |   |          |       |          |                         |
| Analog signal range  |                            | $T_A = -40^\circ\text{C}$ to $+125^\circ\text{C}$  |   | $V_{SS}$ |       | $V_{DD}$ | V                       |
| $R_{ON}$             | On-resistance              | $V_S = 10\text{ V}$ , $I_S = -1\text{ mA}$   | $T_A = -40^\circ\text{C}$ to $+85^\circ\text{C}$  |          | 235   | 340      | $\Omega$                |
|                      |                            |  | $T_A = -40^\circ\text{C}$ to $+125^\circ\text{C}$ |          |       | 390      |                         |
|                      |                            |  |   |          |       | 430      |                         |
| $\Delta R_{ON}$      | On-resistance match        | $V_S = 10\text{ V}$ , $I_S = -1\text{ mA}$   | $T_A = -40^\circ\text{C}$ to $+85^\circ\text{C}$  |          | 7     | 20       | $\Omega$                |
|                      |                            |  | $T_A = -40^\circ\text{C}$ to $+125^\circ\text{C}$ |          |       | 35       |                         |
|                      |                            |  |   |          |       | 40       |                         |
| On-resistance drift  |                            | $V_S = 10\text{ V}$  |   |          | 1.07  |          | $\Omega/^\circ\text{C}$ |
| $I_{S(OFF)}$         | Input leakage current      | Switch state is off,<br>$V_S = 1\text{ V}$ and $V_D = 10\text{ V}$ ,<br>or $V_S = 10\text{ V}$ and $V_D = 1\text{ V}$ <sup>(1)</sup> | $T_A = -40^\circ\text{C}$ to $+85^\circ\text{C}$  | -1       | 0.001 | 1        | nA                      |
|                      |                            |  | $T_A = -40^\circ\text{C}$ to $+125^\circ\text{C}$ | -10      |       | 10       |                         |
| $I_{D(OFF)}$         | Output off leakage current | Switch state is off,<br>$V_S = 1\text{ V}$ and $V_D = 10\text{ V}$ ,<br>or $V_S = 10\text{ V}$ and $V_D = 1\text{ V}$ <sup>(1)</sup> | $T_A = -40^\circ\text{C}$ to $+85^\circ\text{C}$  | -25      |       | 25       | nA                      |
|                      |                            |  | $T_A = -40^\circ\text{C}$ to $+125^\circ\text{C}$ | -1       | 0.01  | 1        |                         |
| $I_{D(ON)}$          | Output on leakage current  | Switch state is on,<br>$V_D = 1\text{ V}$ and $10\text{ V}$ , $V_S =$<br>floating  | $T_A = -40^\circ\text{C}$ to $+85^\circ\text{C}$  | -10      |       | 10       | nA                      |
|                      |                            |  | $T_A = -40^\circ\text{C}$ to $+125^\circ\text{C}$ | -25      |       | 25       |                         |
|                      |                            |  |   | -50      |       | 50       |                         |
| <b>LOGIC INPUT</b>   |                            |  |   |          |       |          |                         |
| $V_{IH}$             | Logic voltage high         |  |   | 2.0      |       |          | V                       |
| $V_{IL}$             | Logic voltage low          |  |   |          |       | 0.8      | V                       |
| $I_D$                | Input current              |  |   |          |       | 0.1      | $\mu\text{A}$           |

 (1) When  $V_S$  is 1 V,  $V_D$  is 10 V, and vice versa.

**MUX506, MUX507**

SBAS803A –NOVEMBER 2016–REVISED NOVEMBER 2017

www.ti.com

**Electrical Characteristics: Single Supply (continued)**at  $T_A = 25^\circ\text{C}$ ,  $V_{DD} = 12\text{ V}$ , and  $V_{SS} = 0\text{ V}$  (unless otherwise noted)

| PARAMETER   |                              | TEST CONDITIONS  |  | MIN           | TYP        | MAX  | UNIT          |
|---|------------------------------|--|--|---------------|------------|------|---------------|
| <b>SWITCH DYNAMIC CHARACTERISTICS<sup>(2)</sup></b> |                              |  |  |               |            |      |               |
| $t_{ON}$  | Enable turn-on time          | $V_S = 8\text{ V}$ , $R_L = 300\ \Omega$ ,<br>$C_L = 35\text{ pF}$   |  |               | 90         | 145  | ns            |
|   |                              |  | $T_A = -40^\circ\text{C to } +85^\circ\text{C}$  |               |            | 145  |               |
|   |                              |  | $T_A = -40^\circ\text{C to } +125^\circ\text{C}$ |               |            | 149  |               |
| $t_{OFF}$   | Enable turn-off time         | $V_S = 8\text{ V}$ , $R_L = 300\ \Omega$ ,<br>$C_L = 35\text{ pF}$   |  |               | 66         | 84   | ns            |
|   |                              |  | $T_A = -40^\circ\text{C to } +85^\circ\text{C}$  |               |            | 94   |               |
|   |                              |  | $T_A = -40^\circ\text{C to } +125^\circ\text{C}$ |               |            | 102  |               |
| $t_t$   | Transition time              | $V_S = 8\text{ V}$ , $C_L = 35\text{ pF}$  |  |               | 107        | 147  | ns            |
|   |                              | $V_S = 8\text{ V}$ , $R_L = 300\ \Omega$ ,<br>$C_L = 35\text{ pF}$ ,   | $T_A = -40^\circ\text{C to } +85^\circ\text{C}$  |               |            | 153  |               |
|   |                              | $V_S = 8\text{ V}$ , $R_L = 300\ \Omega$ ,<br>$C_L = 35\text{ pF}$ ,   | $T_A = -40^\circ\text{C to } +125^\circ\text{C}$ |               |            | 155  |               |
| $t_{BBM}$   | Break-before-make time delay | $V_S = 8\text{ V}$ , $R_L = 300\ \Omega$ , $C_L = 35\text{ pF}$ , $T_A = -40^\circ\text{C to } +125^\circ\text{C}$ |  | 30            | 54         |      | ns            |
| $Q_J$   | Charge injection             | $C_L = 1\text{ nF}$ , $R_S = 0\ \Omega$  | $V_S = 6\text{ V}$                               | TSSOP package | 0.12       |      | pC            |
|   |                              |  |  | SOIC package  | 0.38       |      |               |
|   |                              |  | $V_S = 0\text{ V to } 12\text{ V}$               | TSSOP         | $\pm 0.17$ |      |               |
|   |                              |  |  | SOIC package  | $\pm 0.48$ |      |               |
| Off-isolation                                       |                              | $R_L = 50\ \Omega$ , $V_S = 1\text{ V}_{RMS}$ ,<br>$f = 1\text{ MHz}$  | Nonadjacent channel to D,<br>DA, DB              | TSSOP package | -97        |      | dB            |
|   |                              |  |  | SOIC package  | -94        |      |               |
|   |                              |  | Adjacent channel to D, DA,<br>DB                 | TSSOP package | -94        |      |               |
|   |                              |  |  | SOIC package  | -88        |      |               |
| Channel-to-channel crosstalk                        |                              | $R_L = 50\ \Omega$ , $V_S = 1\text{ V}_{RMS}$ ,<br>$f = 1\text{ MHz}$  | Nonadjacent channels                             | TSSOP package | -100       |      | dB            |
|   |                              |  |  | SOIC package  | -99        |      |               |
|   |                              |  | Adjacent channels                                | TSSOP         | -88        |      |               |
|   |                              |  |  | SOIC package  | -83        |      |               |
| $C_{S(OFF)}$  | Input off-capacitance        | $f = 1\text{ MHz}$ , $V_S = 6\text{ V}$  |  |               | 2.4        | 3.4  | pF            |
| $C_{D(OFF)}$  | Output off-capacitance       | $f = 1\text{ MHz}$ , $V_S = 6\text{ V}$  | MUX506   |               | 14         | 15.4 | pF            |
|   |                              |  | MUX507   |               | 7.8        | 9.1  |               |
| $C_{S(ON)}$ ,<br>$C_{D(ON)}$                        | Output on-capacitance        | $f = 1\text{ MHz}$ , $V_S = 6\text{ V}$  | MUX506   |               | 16.2       | 18   | pF            |
|   |                              |  | MUX507   |               | 9.9        | 11.6 |               |
| <b>POWER SUPPLY</b>                                 |                              |  |  |               |            |      |               |
| $V_{DD}$ supply current                             |                              | All $V_A = 0\text{ V}$ or $3.3\text{ V}$ ,<br>$V_S = 0\text{ V}$ , $V_{EN} = 3.3\text{ V}$                         |  |               | 41         | 59   | $\mu\text{A}$ |
|   |                              |  | $T_A = -40^\circ\text{C to } +85^\circ\text{C}$  |               |            | 62   |               |
|   |                              |  | $T_A = -40^\circ\text{C to } +125^\circ\text{C}$ |               |            | 83   |               |
| $V_{SS}$ supply current                             |                              | All $V_A = 0\text{ V}$ or $3.3\text{ V}$ ,<br>$V_S = 0\text{ V}$ , $V_{EN} = 3.3\text{ V}$                         |  |               | 22         | 34   | $\mu\text{A}$ |
|   |                              |  | $T_A = -40^\circ\text{C to } +85^\circ\text{C}$  |               |            | 37   |               |
|   |                              |  | $T_A = -40^\circ\text{C to } +125^\circ\text{C}$ |               |            | 57   |               |

(2) Specified by design, not subject to production test.

### 6.7 Typical Characteristics

at  $T_A = 25^\circ\text{C}$ ,  $V_{DD} = 15\text{ V}$ , and  $V_{SS} = -15\text{ V}$  (unless otherwise noted)

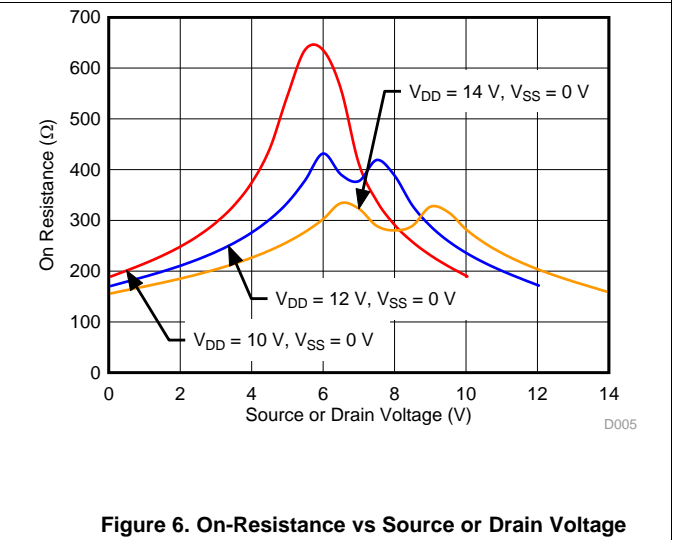
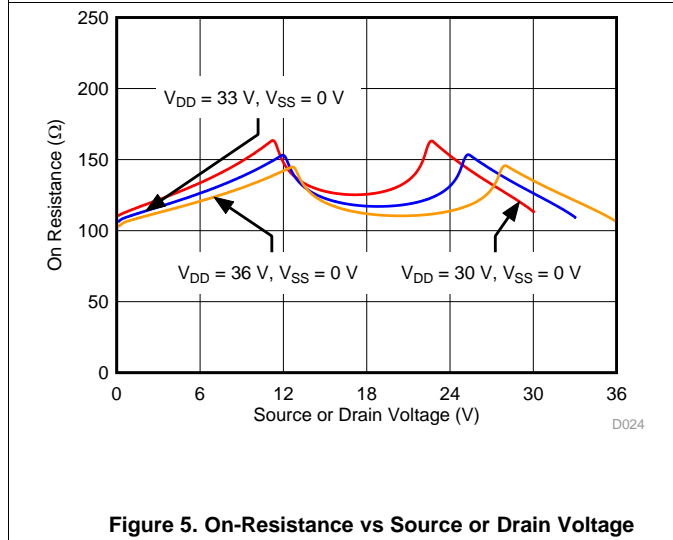
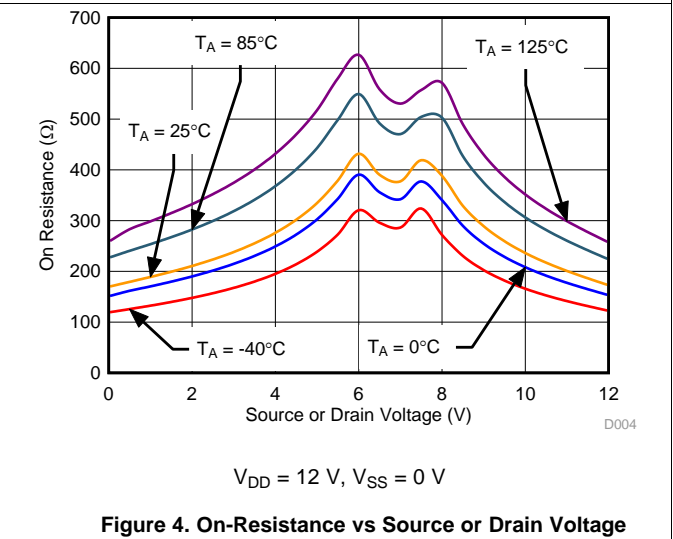
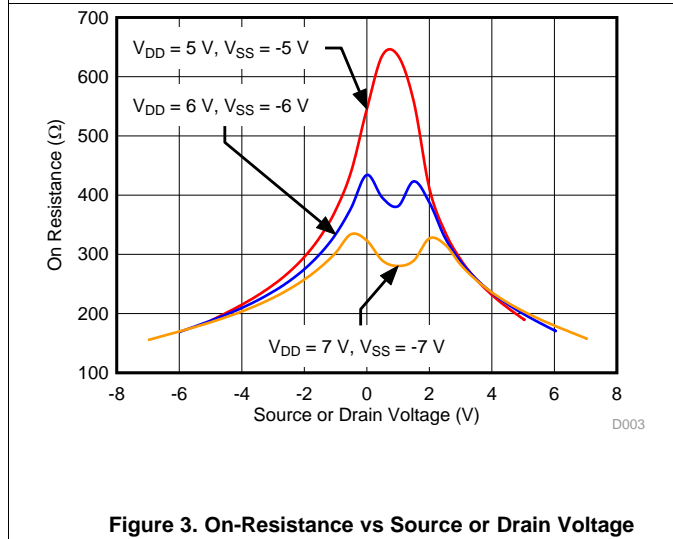
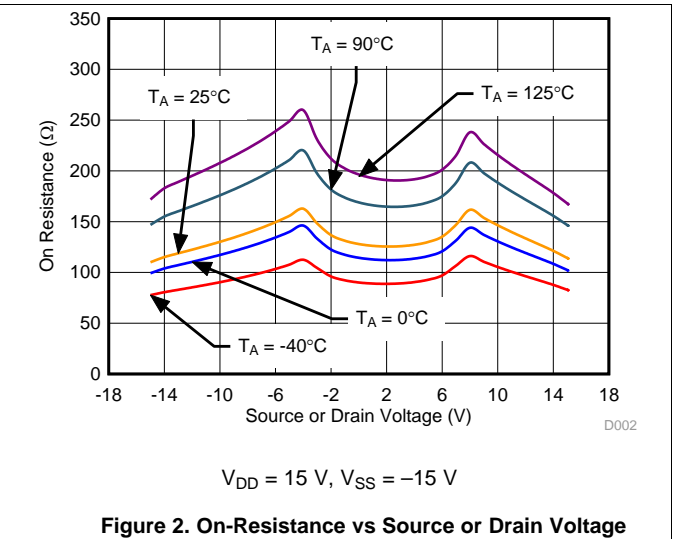
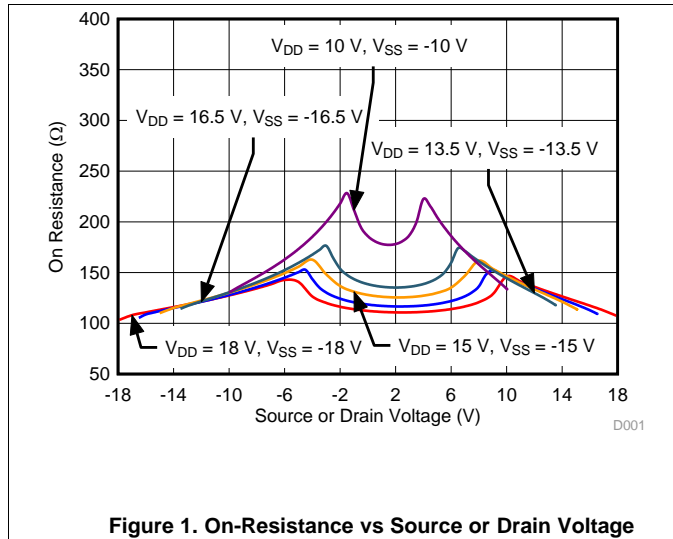

**MUX506, MUX507**

SBAS803A –NOVEMBER 2016–REVISED NOVEMBER 2017

www.ti.com

**Typical Characteristics (continued)**

at  $T_A = 25^\circ\text{C}$ ,  $V_{DD} = 15\text{ V}$ , and  $V_{SS} = -15\text{ V}$  (unless otherwise noted)

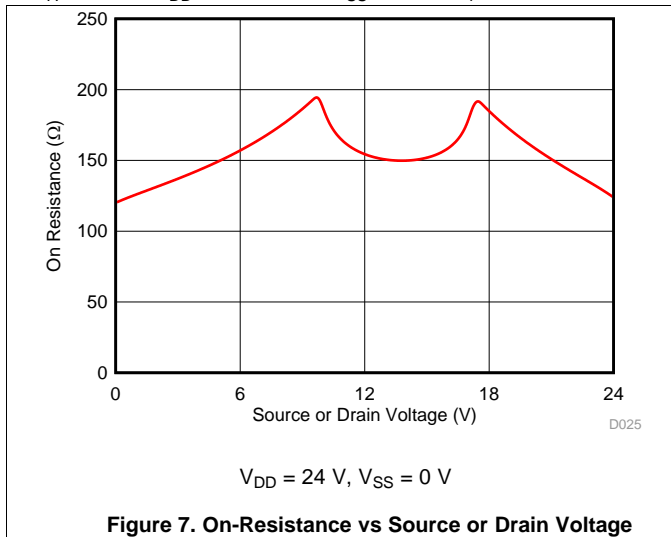

**Figure 7. On-Resistance vs Source or Drain Voltage**

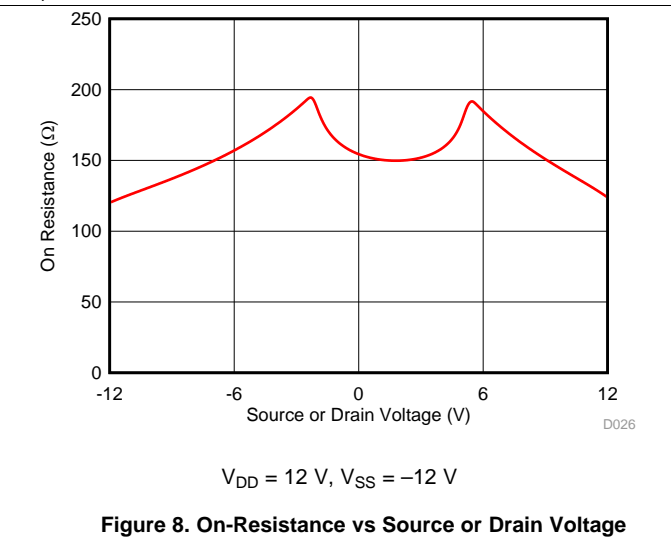

**Figure 8. On-Resistance vs Source or Drain Voltage**

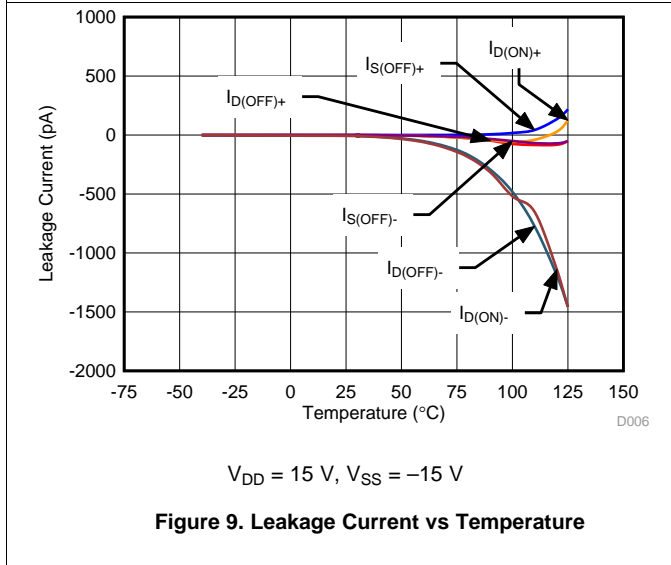

**Figure 9. Leakage Current vs Temperature**

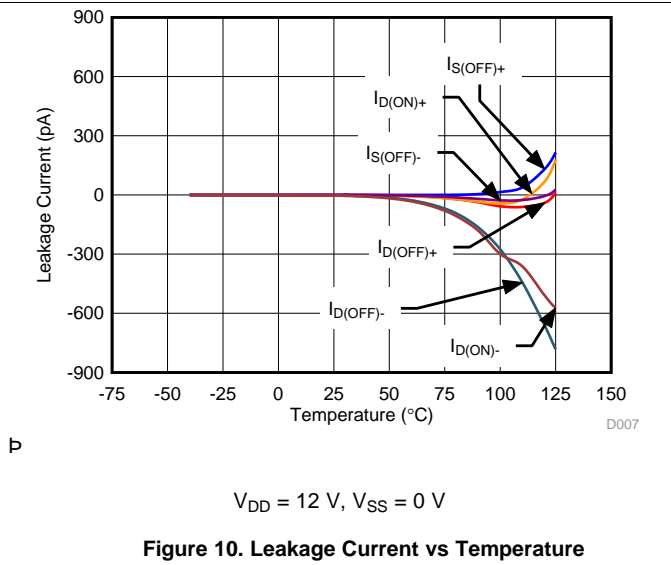

**Figure 10. Leakage Current vs Temperature**

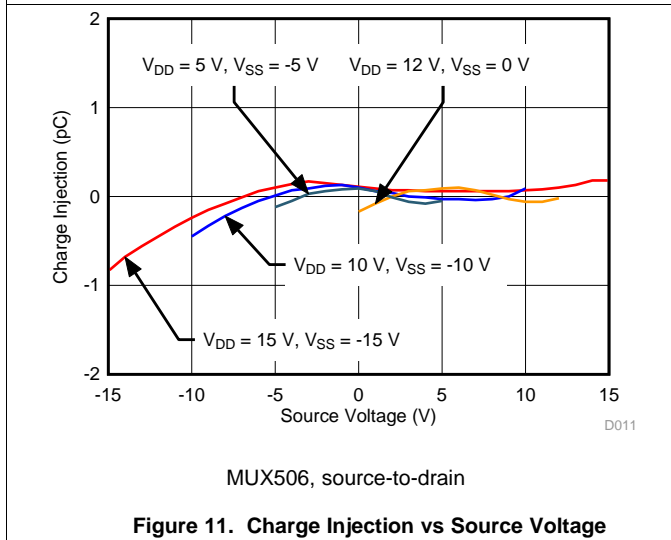

**Figure 11. Charge Injection vs Source Voltage**

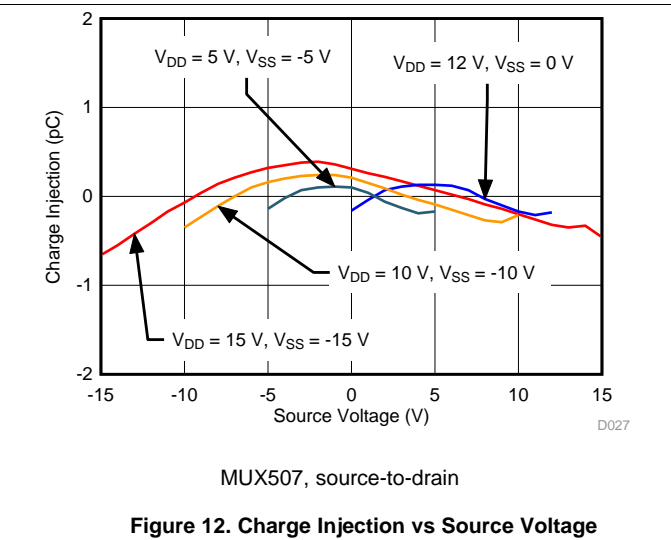

**Figure 12. Charge Injection vs Source Voltage**

**Typical Characteristics (continued)**

at  $T_A = 25^\circ\text{C}$ ,  $V_{DD} = 15\text{ V}$ , and  $V_{SS} = -15\text{ V}$  (unless otherwise noted)

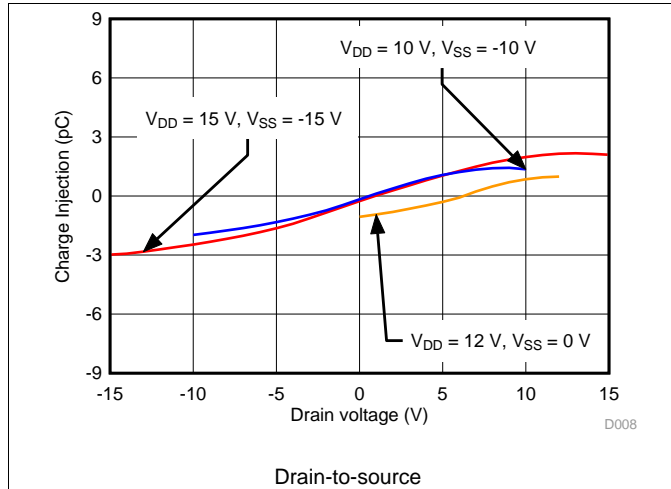

**Figure 13. Charge Injection vs Drain Voltage**

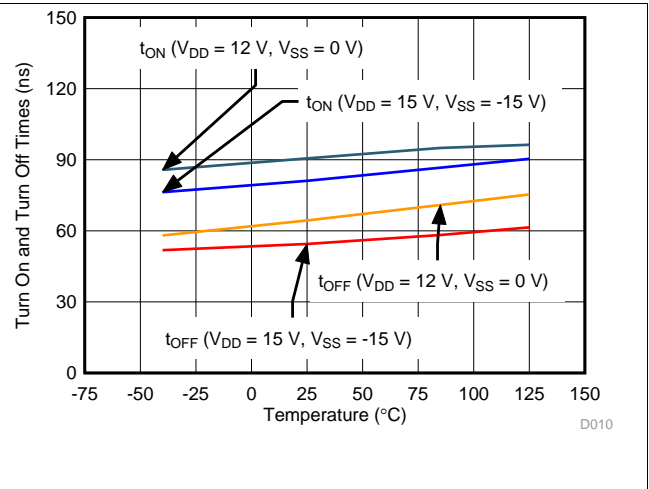

**Figure 14. Turn-On and Turn-Off Times vs Temperature**

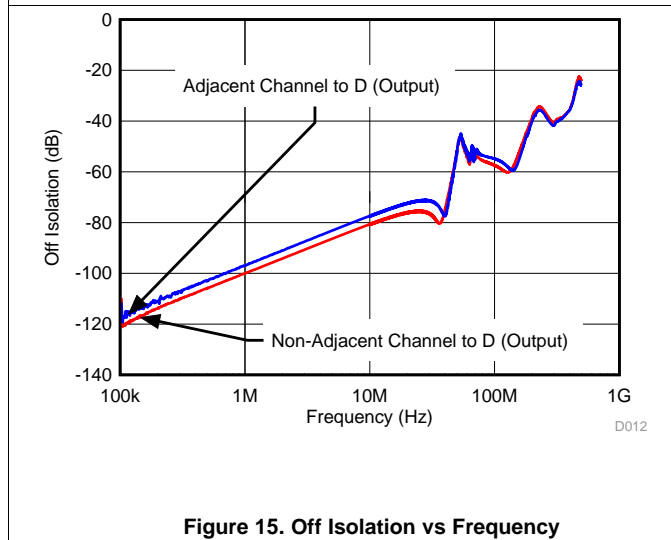

**Figure 15. Off Isolation vs Frequency**

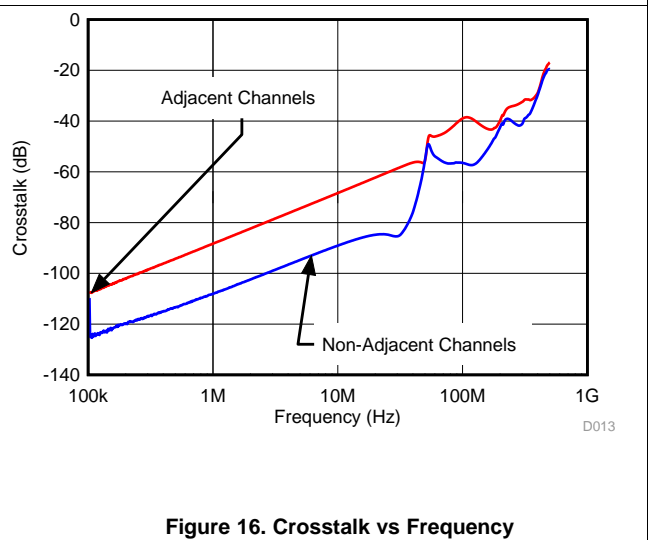

**Figure 16. Crosstalk vs Frequency**

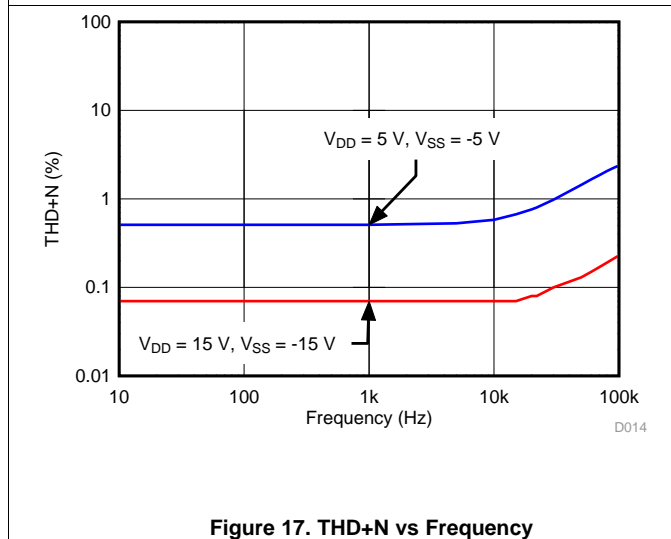

**Figure 17. THD+N vs Frequency**

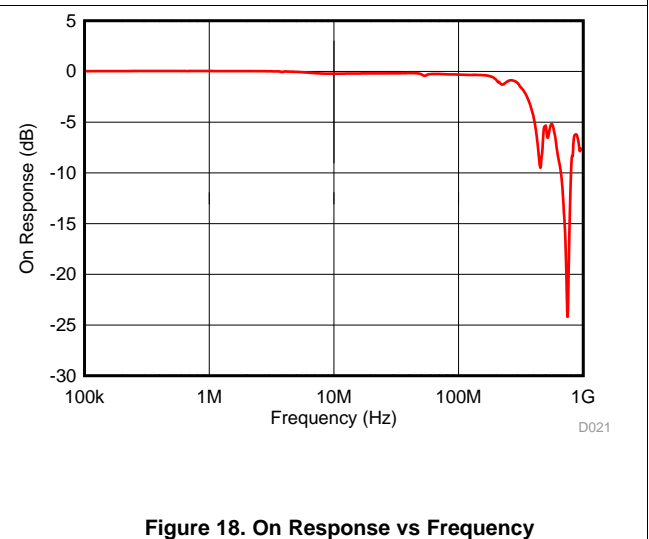

**Figure 18. On Response vs Frequency**

**MUX506, MUX507**

SBAS803A –NOVEMBER 2016–REVISED NOVEMBER 2017

www.ti.com

**Typical Characteristics (continued)**

at  $T_A = 25^\circ\text{C}$ ,  $V_{DD} = 15\text{ V}$ , and  $V_{SS} = -15\text{ V}$  (unless otherwise noted)

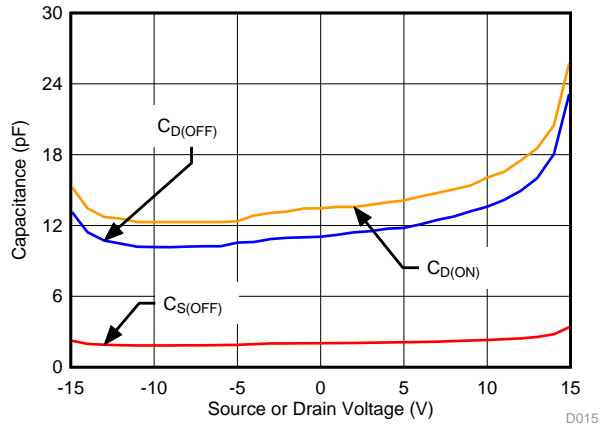

MUX506,  $V_{DD} = 15\text{ V}$ ,  $V_{SS} = -15\text{ V}$

**Figure 19. Capacitance vs Source Voltage**

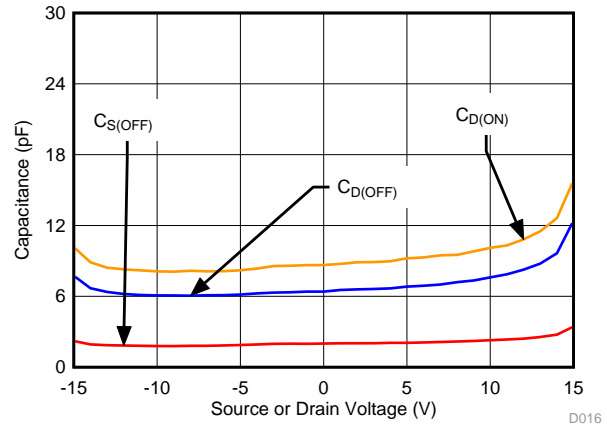

MUX507,  $V_{DD} = 15\text{ V}$ ,  $V_{SS} = -15\text{ V}$

**Figure 20. Capacitance vs Source Voltage**

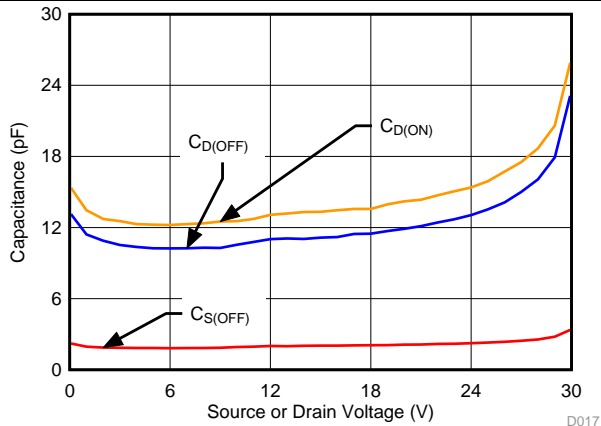

MUX506,  $V_{DD} = 30\text{ V}$ ,  $V_{SS} = 0\text{ V}$

**Figure 21. Capacitance vs Source Voltage**

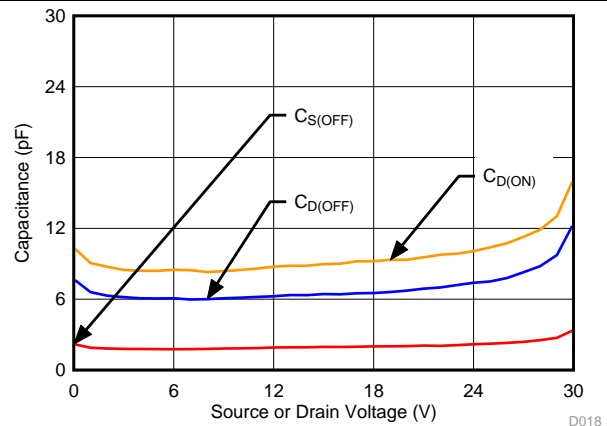

MUX507,  $V_{DD} = 30\text{ V}$ ,  $V_{SS} = 0\text{ V}$

**Figure 22. Capacitance vs Source Voltage**

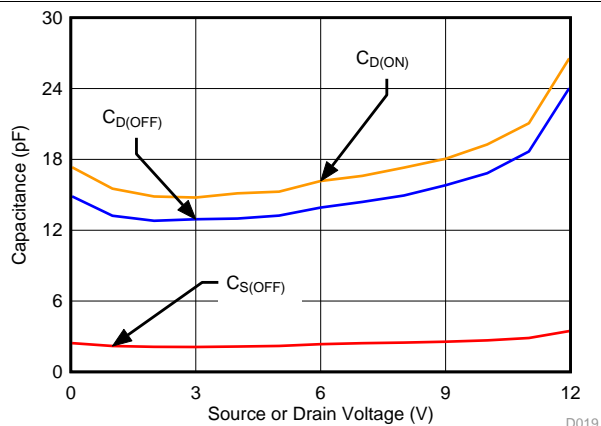

MUX506,  $V_{DD} = 12\text{ V}$ ,  $V_{SS} = 0\text{ V}$

**Figure 23. Capacitance vs Source Voltage**

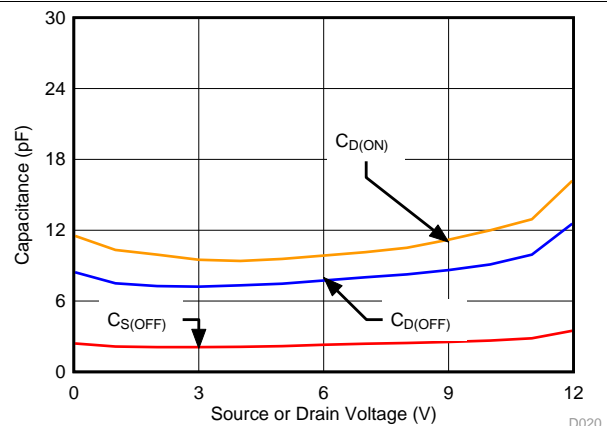

MUX507,  $V_{DD} = 12\text{ V}$ ,  $V_{SS} = 0\text{ V}$

**Figure 24. Capacitance vs Source Voltage**

**Typical Characteristics (continued)**

at  $T_A = 25^\circ\text{C}$ ,  $V_{DD} = 15\text{ V}$ , and  $V_{SS} = -15\text{ V}$  (unless otherwise noted)

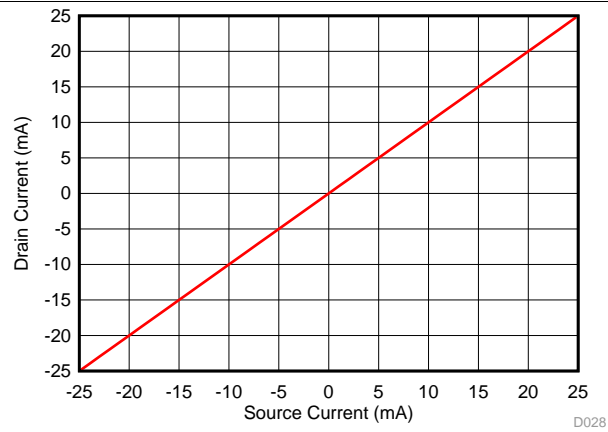

**Figure 25. Source Current vs Drain Current**

**MUX506, MUX507**

SBAS803A –NOVEMBER 2016–REVISED NOVEMBER 2017

www.ti.com

**7 Parameter Measurement Information****7.1 Truth Tables****Table 1. MUX506**

| EN | A3               | A2               | A1               | A0               | ON-CHANNEL           |
|----|------------------|------------------|------------------|------------------|----------------------|
| 0  | X <sup>(1)</sup> | X <sup>(1)</sup> | X <sup>(1)</sup> | X <sup>(1)</sup> | All channels are off |
| 1  | 0                | 0                | 0                | 0                | Channel 1            |
| 1  | 0                | 0                | 0                | 1                | Channel 2            |
| 1  | 0                | 0                | 1                | 0                | Channel 3            |
| 1  | 0                | 0                | 1                | 1                | Channel 4            |
| 1  | 0                | 1                | 0                | 0                | Channel 5            |
| 1  | 0                | 1                | 0                | 1                | Channel 6            |
| 1  | 0                | 1                | 1                | 0                | Channel 7            |
| 1  | 0                | 1                | 1                | 1                | Channel 8            |
| 1  | 1                | 0                | 0                | 0                | Channel 9            |
| 1  | 1                | 0                | 0                | 1                | Channel 10           |
| 1  | 1                | 0                | 1                | 0                | Channel 11           |
| 1  | 1                | 0                | 1                | 1                | Channel 12           |
| 1  | 1                | 1                | 0                | 0                | Channel 13           |
| 1  | 1                | 1                | 0                | 1                | Channel 14           |
| 1  | 1                | 1                | 1                | 0                | Channel 15           |
| 1  | 1                | 1                | 1                | 1                | Channel 16           |

(1) X denotes *don't care*..**Table 2. MUX507**

| EN | A2               | A1               | A0               | ON-CHANNEL           |
|----|------------------|------------------|------------------|----------------------|
| 0  | X <sup>(1)</sup> | X <sup>(1)</sup> | X <sup>(1)</sup> | All channels are off |
| 1  | 0                | 0                | 0                | Channels 1A and 1B   |
| 1  | 0                | 0                | 1                | Channels 2A and 2B   |
| 1  | 0                | 1                | 0                | Channels 3A and 3B   |
| 1  | 0                | 1                | 1                | Channels 4A and 4B   |
| 1  | 1                | 0                | 0                | Channels 5A and 5B   |
| 1  | 1                | 0                | 1                | Channels 6A and 6B   |
| 1  | 1                | 1                | 0                | Channels 7A and 7B   |
| 1  | 1                | 1                | 1                | Channels 8A and 8B   |

(1) X denotes *don't care*.

## 7.2 On-Resistance

The on-resistance of the MUX50x is the ohmic resistance across the source (Sx, SxA, or SxB) and drain (D, DA, or DB) pins of the device. The on-resistance varies with input voltage and supply voltage. The symbol  $R_{ON}$  is used to denote on-resistance. The measurement setup used to measure  $R_{ON}$  is shown in Figure 26. Voltage (V) and current ( $I_{CH}$ ) are measured using this setup, and  $R_{ON}$  is computed as shown in Equation 1:

$$R_{ON} = V / I_{CH} \tag{1}$$

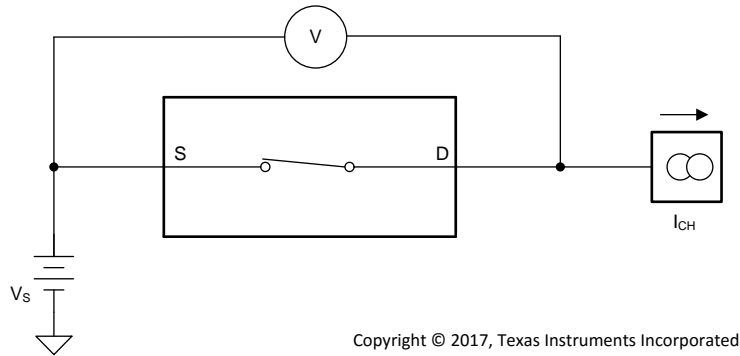

Figure 26. On-Resistance Measurement Setup

## 7.3 Off Leakage

There are two types of leakage currents associated with a switch during the OFF state:

1. Source off-leakage current
2. Drain off-leakage current

Source leakage current is defined as the leakage current flowing into or out of the source pin when the switch is off. This current is denoted by the symbol  $I_{S(OFF)}$ .

Drain leakage current is defined as the leakage current flowing into or out of the drain pin when the switch is off. This current is denoted by the symbol  $I_{D(OFF)}$ .

The setup used to measure both off-leakage currents is shown in Figure 27

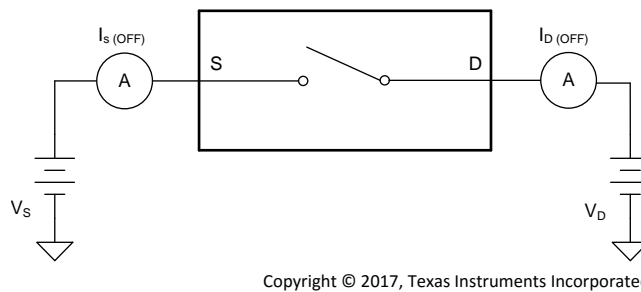

Figure 27. Off-Leakage Measurement Setup

## MUX506, MUX507

SBAS803A –NOVEMBER 2016–REVISED NOVEMBER 2017

www.ti.com

### 7.4 On-Leakage Current

On-leakage current is defined as the leakage current that flows into or out of the drain pin when the switch is in the ON state. The source pin is left floating during the measurement. Figure 28 shows the circuit used for measuring the on-leakage current, denoted by  $I_{D(ON)}$ .

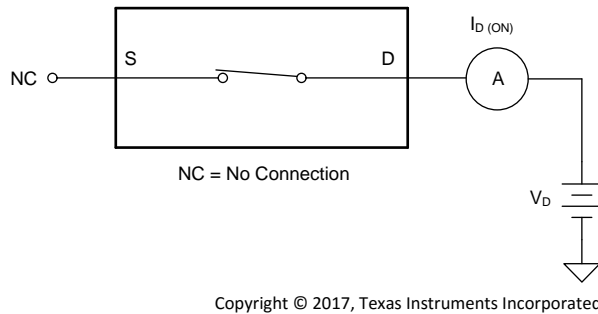

Figure 28. On-Leakage Measurement Setup

### 7.5 Transition Time

Transition time is defined as the time taken by the output of the MUX50x to rise or fall to 90% of the transition after the digital address signal has fallen or risen to 50% of the transition. Figure 29 shows the setup used to measure transition time, denoted by the symbol  $t_t$ .

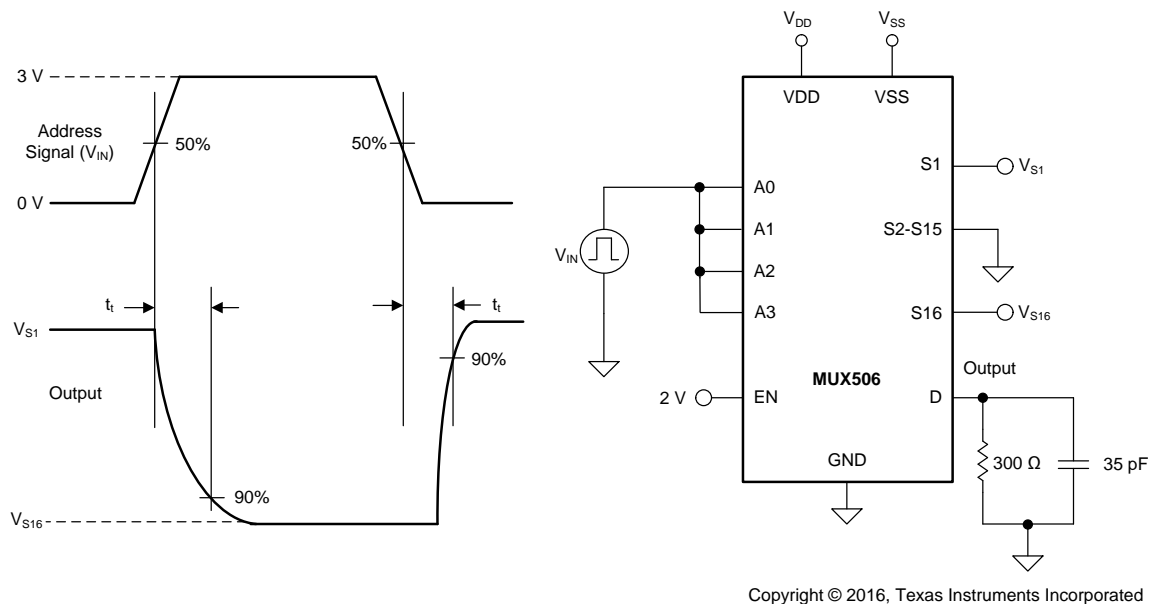

Figure 29. Transition-Time Measurement Setup

### 7.6 Break-Before-Make Delay

Break-before-make delay is a safety feature that prevents two inputs from connecting when the MUX50x is switching. The MUX50x output first breaks from the ON-state switch before making the connection with the next ON-state switch. The time delay between the *break* and the *make* is known as break-before-make delay. Figure 30 shows the setup used to measure break-before-make delay, denoted by the symbol  $t_{BBM}$ .

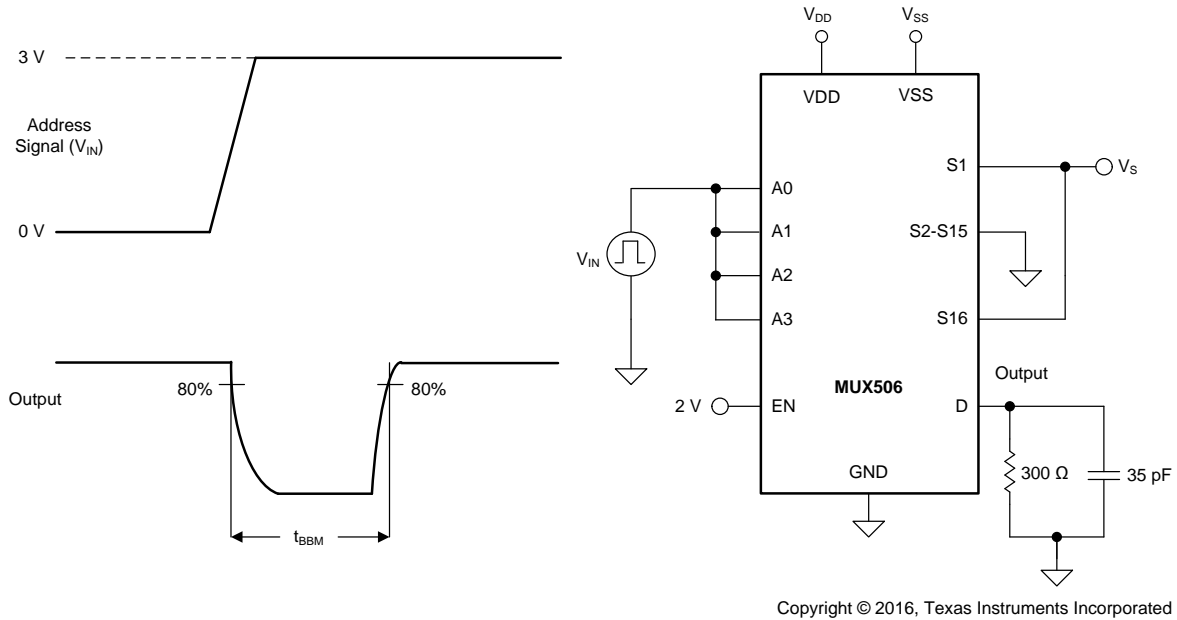

Figure 30. Break-Before-Make Delay Measurement Setup

## MUX506, MUX507

SBAS803A –NOVEMBER 2016–REVISED NOVEMBER 2017

www.ti.com

### 7.7 Turn-On and Turn-Off Time

Turn-on time is defined as the time taken by the output of the MUX50x to rise to 90% final value after the enable signal has risen to 50% final value. Figure 31 shows the setup used to measure turn-on time. Turn-on time is denoted by the symbol  $t_{ON}$ .

Turn off time is defined as the time taken by the output of the MUX50x to fall to 10% initial value after the enable signal has fallen to 50% initial value. Figure 31 shows the setup used to measure turn-off time. Turn-off time is denoted by the symbol  $t_{OFF}$ .

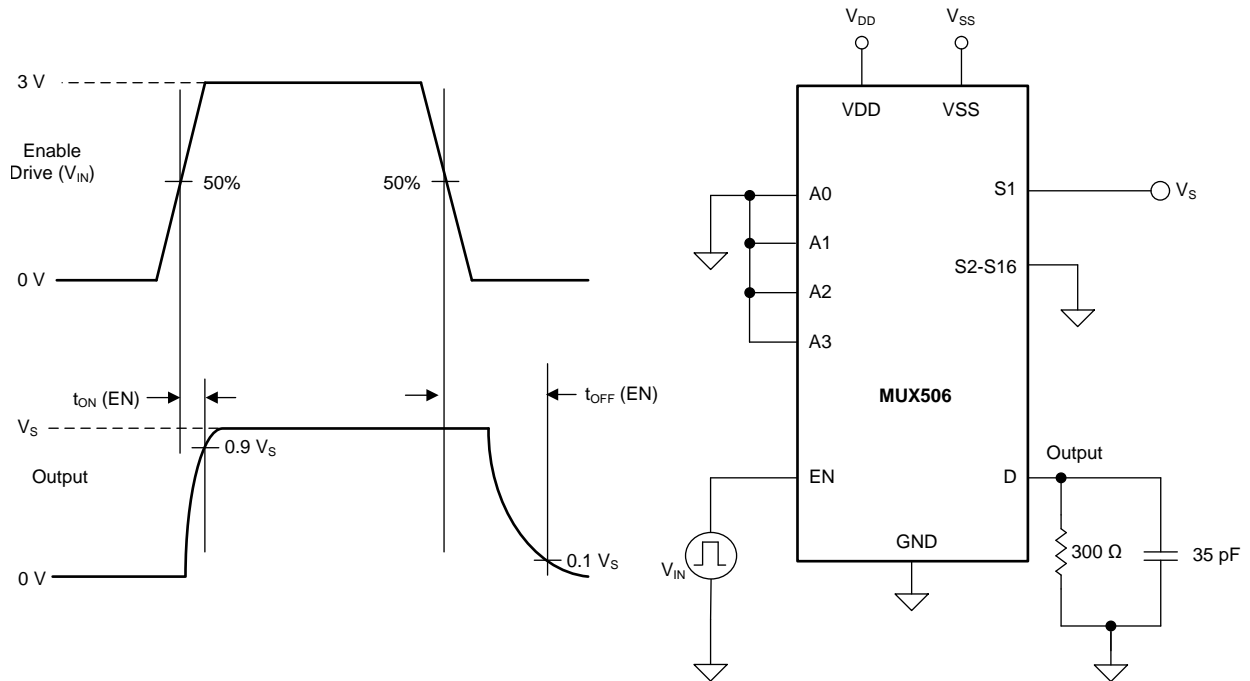

Copyright © 2016, Texas Instruments Incorporated

**Figure 31. Turn-On and Turn-Off Time Measurement Setup**

### 7.8 Charge Injection

The MUX50x have a simple transmission-gate topology. Any mismatch in capacitance between the NMOS and PMOS transistors results in a charge injected into the drain or source during the falling or rising edge of the gate signal. The amount of charge injected into the source or drain of the device is known as charge injection, and is denoted by the symbol  $Q_{INJ}$ . Figure 32 shows the setup used to measure charge injection.

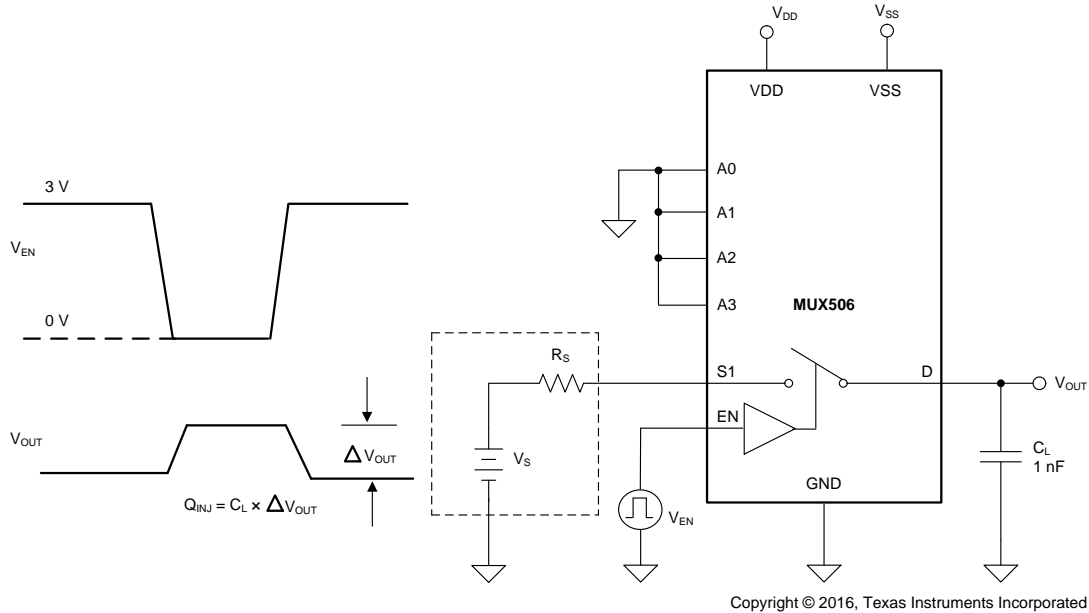

**Figure 32. Charge-Injection Measurement Setup**

**MUX506, MUX507**

SBAS803A –NOVEMBER 2016–REVISED NOVEMBER 2017

www.ti.com

**7.9 Off Isolation**

Off isolation is defined as the voltage at the drain pin (D, DA, or DB) of the MUX50x when a 1- $V_{RMS}$  signal is applied to the source pin (Sx, SxA, or SxB) of an off-channel. Figure 33 shows the setup used to measure off isolation. Use Equation 2 to compute off isolation.

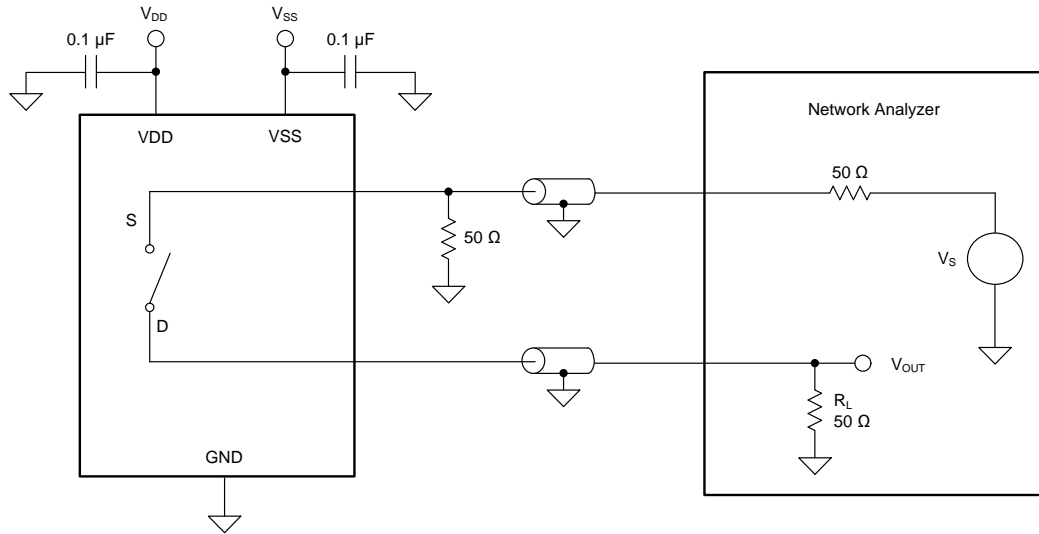

Copyright © 2017, Texas Instruments Incorporated

**Figure 33. Off Isolation Measurement Setup**

$$\text{Off Isolation} = 20 \cdot \text{Log} \left( \frac{V_{OUT}}{V_S} \right) \tag{2}$$

**7.10 Channel-to-Channel Crosstalk**

Channel-to-channel crosstalk is defined as the voltage at the source pin (Sx, SxA, or SxB) of an off-channel, when a 1- $V_{RMS}$  signal is applied at the source pin of an on-channel. Figure 34 shows the setup used to measure channel-to-channel crosstalk. Use Equation 3 to compute, channel-to-channel crosstalk.

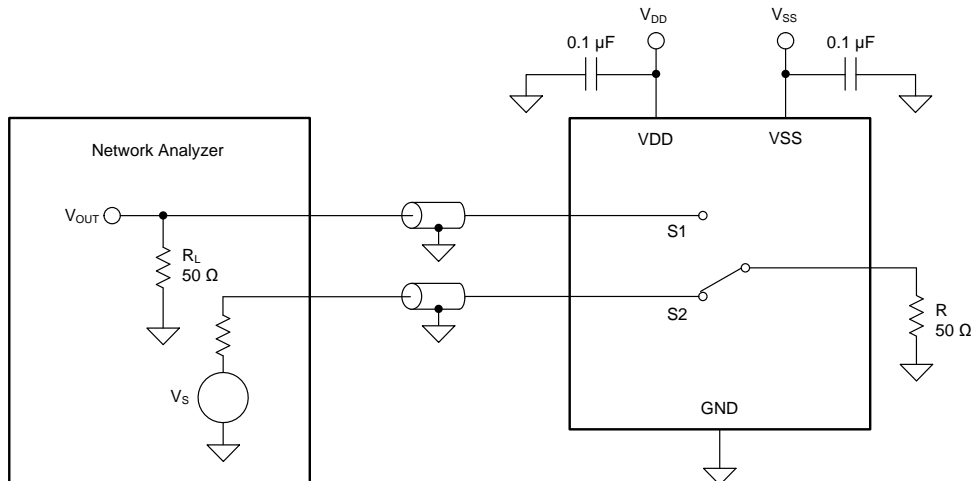

Copyright © 2017, Texas Instruments Incorporated

**Figure 34. Channel-to-Channel Crosstalk Measurement Setup**

$$\text{Channel-to-Channel Crosstalk} = 20 \cdot \text{Log} \left( \frac{V_{OUT}}{V_S} \right) \tag{3}$$

## 7.11 Bandwidth

Bandwidth is defined as the range of frequencies that are attenuated by less than 3 dB when the input is applied to the source pin of an on-channel, and the output measured at the drain pin of the MUX50x. Figure 35 shows the setup used to measure bandwidth of the mux. Use Equation 4 to compute the attenuation.

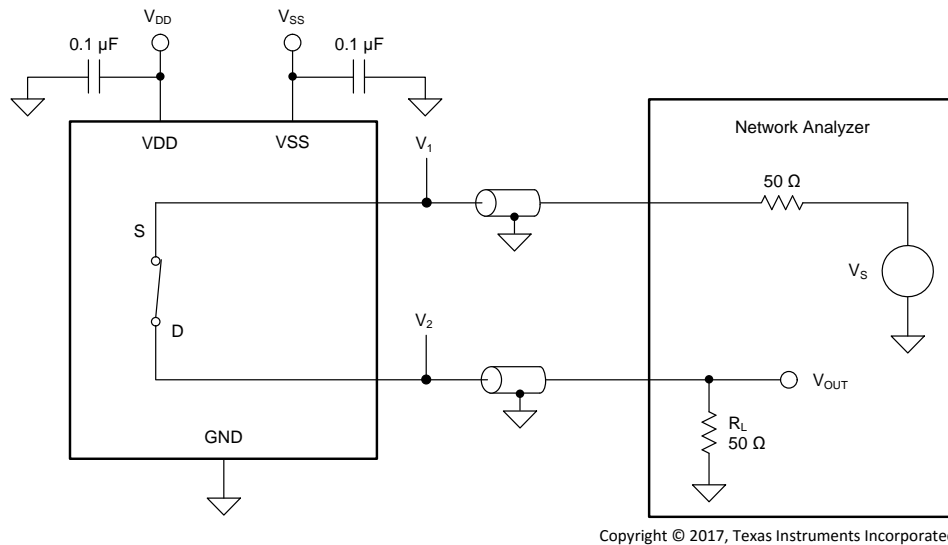

**Figure 35. Bandwidth Measurement Setup**

$$\text{Attenuation} = 20 \cdot \text{Log} \left( \frac{V_2}{V_1} \right)$$

(4)

## 7.12 THD + Noise

The total harmonic distortion (THD) of a signal is a measurement of the harmonic distortion, and is defined as the ratio of the sum of the powers of all harmonic components to the power of the fundamental frequency at the mux output. The on-resistance of the MUX50x varies with the amplitude of the input signal and results in distortion when the drain pin is connected to a low-impedance load. Total harmonic distortion plus noise is denoted as THD+N. Figure 36 shows the setup used to measure THD+N of the MUX50x.

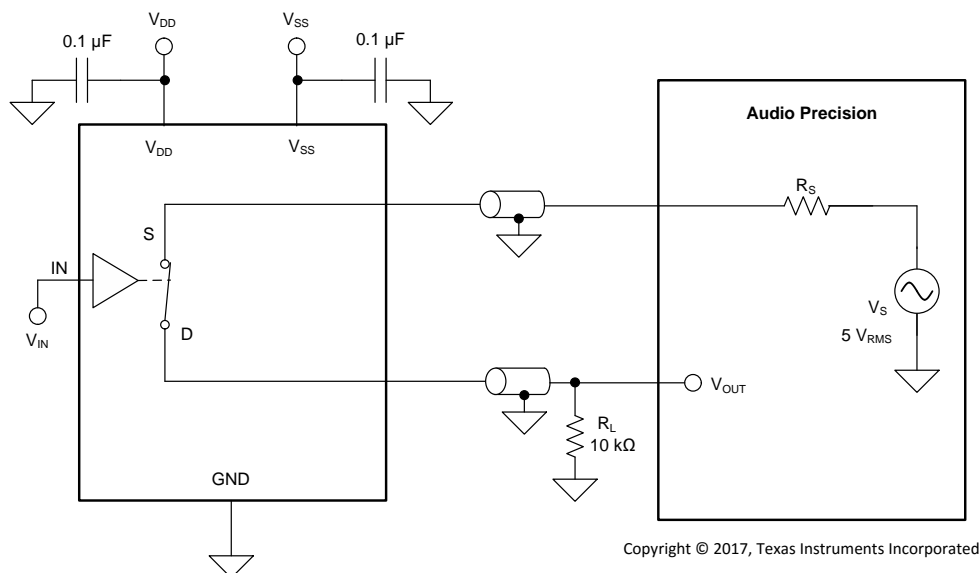

**Figure 36. THD+N Measurement Setup**

## MUX506, MUX507

SBAS803A –NOVEMBER 2016–REVISED NOVEMBER 2017

www.ti.com

# 8 Detailed Description

## 8.1 Overview

The MUX50x are a family of analog multiplexers. The *Functional Block Diagram* section provides a top-level block diagram of both the MUX506 and MUX507. The MUX506 is a 16-channel, single-ended, analog mux. The MUX507 is an 8-channel, differential or dual 8:1, single-ended, analog mux. Each channel is turned on or turned off based on the state of the address lines and enable pin.

## 8.2 Functional Block Diagram

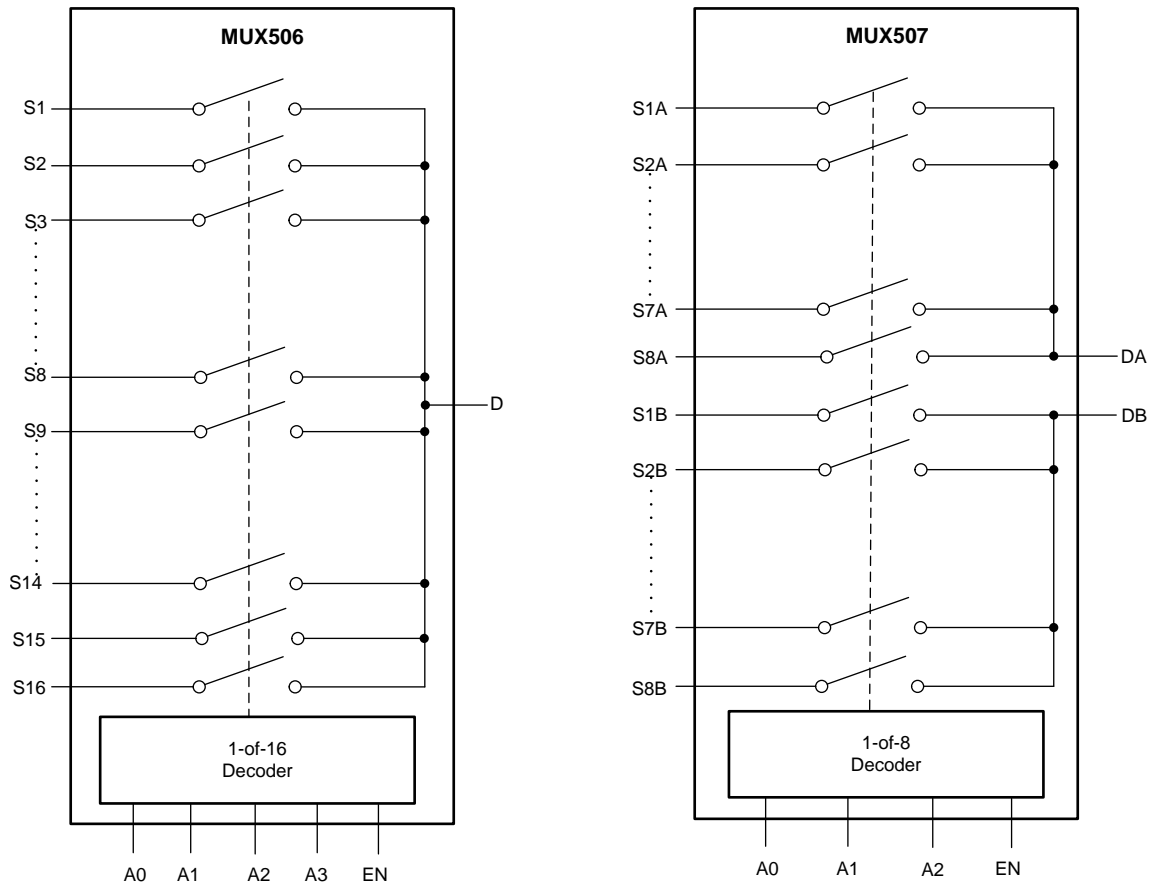

Copyright © 2016, Texas Instruments Incorporated

### 8.3 Feature Description

#### 8.3.1 Ultralow Leakage Current

The MUX50x provide extremely low on- and off-leakage currents. The MUX50x are capable of switching signals from high source-impedance inputs into a high input-impedance op amp with minimal offset error because of the ultra-low leakage currents. Figure 37 shows typical leakage currents of the MUX50x versus temperature.

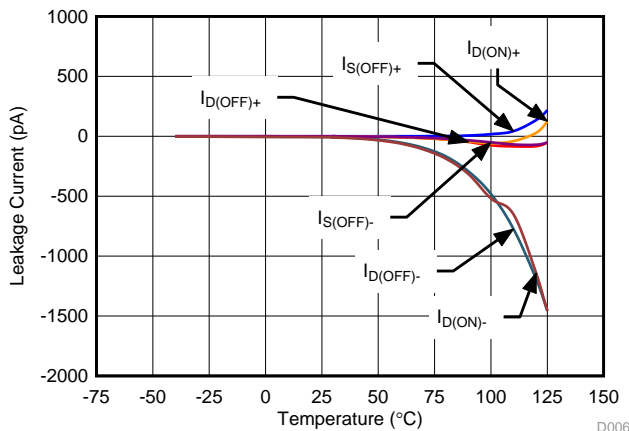
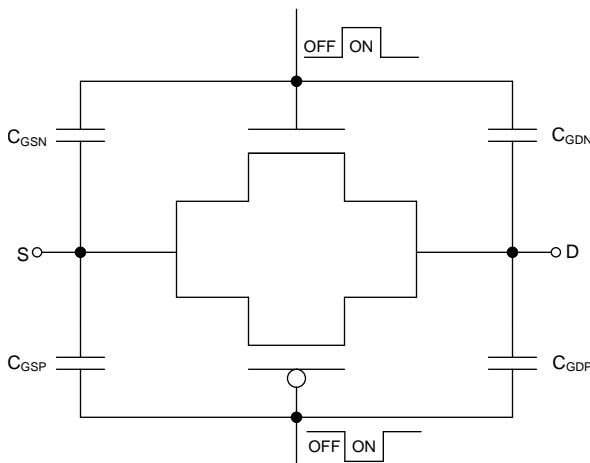

Figure 37. Leakage Current vs Temperature

#### 8.3.2 Ultralow Charge Injection

The MUX50x have a simple transmission gate topology, as shown in Figure 38. Any mismatch in the stray capacitance associated with the NMOS and PMOS causes an output level change whenever the switch is opened or closed.



Copyright © 2017, Texas Instruments Incorporated

Figure 38. Transmission Gate Topology

**MUX506, MUX507**

SBAS803A –NOVEMBER 2016–REVISED NOVEMBER 2017

www.ti.com

**Feature Description (continued)**

The MUX50x have special charge-injection cancellation circuitry that reduces the source-to-drain charge injection to as low as 0.31 pC at  $V_S = 0$  V, and  $\pm 0.9$  pC in the full signal range, as shown in Figure 39.

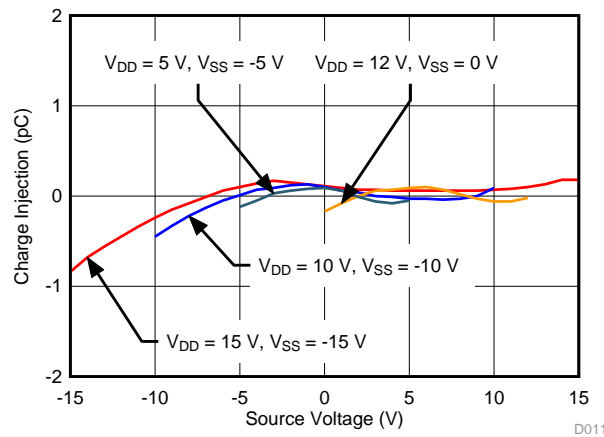

**Figure 39. Source-to-Drain Charge Injection**

The drain-to-source charge injection becomes important when the device is used as a demultiplexer (demux), where D becomes the input and Sx becomes the output. Figure 40 shows the drain-to-source charge injection across the full signal range.

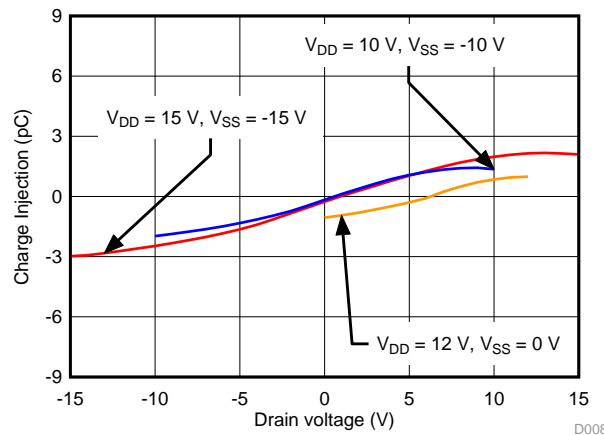

**Figure 40. Drain-to-Source Charge Injection**

## Feature Description (continued)

### 8.3.3 Bidirectional Operation

The MUX50x are operable as both a mux and demux. The source (Sx, SxA, SxB) and drain (D, DA, DB) pins of the MUX50x are used either as input or output. Each MUX50x channel has very similar characteristics in both directions.

### 8.3.4 Rail-to-Rail Operation

The valid analog signal for the MUX50x ranges from  $V_{SS}$  to  $V_{DD}$ . The input signal to the MUX50x swings from  $V_{SS}$  to  $V_{DD}$  without any significant degradation in performance. The on-resistance of the MUX50x varies with input signal, as shown in Figure 41

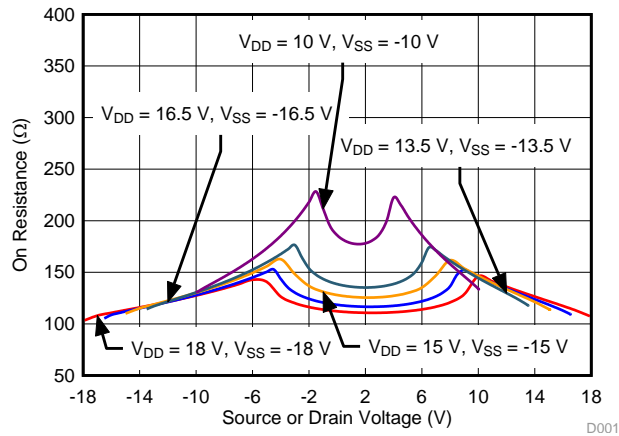

**Figure 41. On-resistance vs Source or Drain Voltage**

## 8.4 Device Functional Modes

When the EN pin of the MUX50x is pulled high, one of the switches is closed based on the state of the address lines. When the EN pin is pulled low, all the switches are in an open state irrespective of the state of the address lines. The EN pin can be connected to  $V_{DD}$  (as high as 36 V).

## MUX506, MUX507

SBAS803A –NOVEMBER 2016–REVISED NOVEMBER 2017

www.ti.com

## 9 Application and Implementation

### NOTE

Information in the following applications sections is not part of the TI component specification, and TI does not warrant its accuracy or completeness. TI's customers are responsible for determining suitability of components for their purposes. Customers should validate and test their design implementation to confirm system functionality.

### 9.1 Application Information

The MUX50x family offers outstanding input/output leakage currents and ultra-low charge injection. These devices operate up to 36 V, and offer true rail-to-rail input and output. The on-capacitance of the MUX50x is very low. These features makes the MUX50x a family of precision, robust, high-performance analog multiplexer for high-voltage, industrial applications.

### 9.2 Typical Application

Figure 42 shows a 16-bit, differential, 8-channel, multiplexed, data-acquisition system. This example is typical in industrial applications that require low distortion and a high-voltage differential input. The circuit uses the ADS8864, a 16-bit, 400-kSPS successive-approximation-resistor (SAR) analog-to-digital converter (ADC), along with a precision, high-voltage, signal-conditioning front end, and a 4-channel differential mux. This TI Precision Design details the process for optimizing the precision, high-voltage, front-end drive circuit using the MUX507, OPA192 and OPA140 to achieve excellent dynamic performance and linearity with the ADS8864.

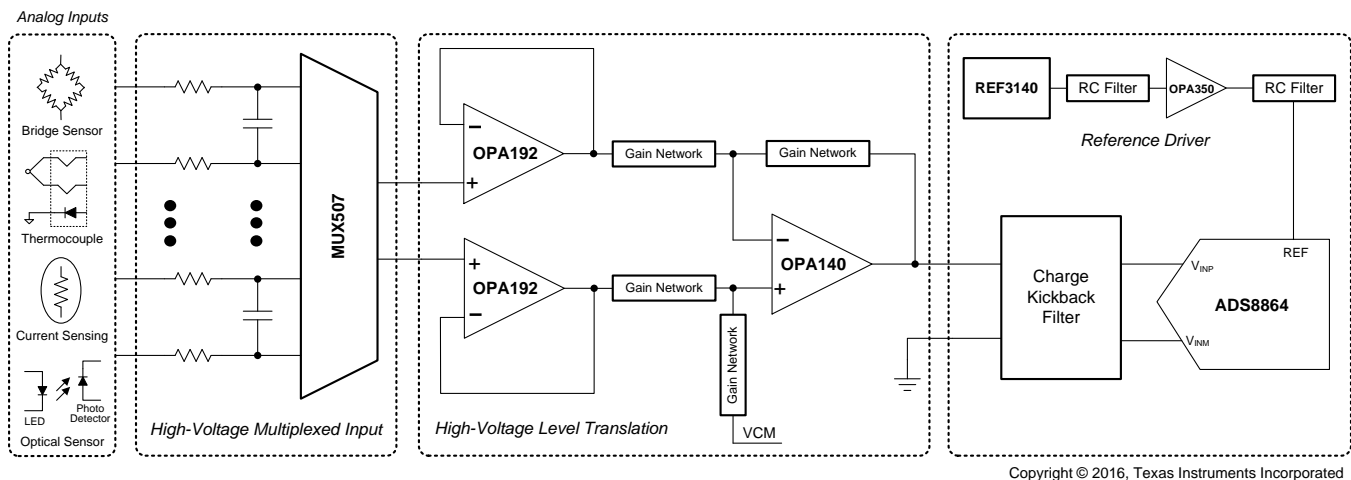

**Figure 42. 16-Bit Precision Multiplexed Data-Acquisition System for High-Voltage Inputs With Lowest Distortion**

#### 9.2.1 Design Requirements

The primary objective is to design a  $\pm 20$  V, differential, 8-channel, multiplexed, data-acquisition system with lowest distortion using the 16-bit ADS8864 at a throughput of 400 kSPS for a 10-kHz, full-scale, pure, sine-wave input. The design requirements for this block design are:

- System supply voltage:  $\pm 15$  V
- ADC supply voltage: 3.3 V
- ADC sampling rate: 400 kSPS
- ADC reference voltage (REFP): 4.096 V
- System input signal: A high-voltage differential input signal with a peak amplitude of 20 V and frequency ( $f_{IN}$ ) of 10 kHz are applied to each differential input of the mux.

## Typical Application (continued)

### 9.2.2 Detailed Design Procedure

The purpose of this precision design is to design an optimal, high-voltage, multiplexed, data-acquisition system for highest system linearity and fast settling. The overall system block diagram is illustrated in [Figure 42](#). The circuit is a multichannel, data-acquisition signal chain consisting of an input low-pass filter, mux, mux output buffer, attenuating SAR ADC driver, and the reference driver. The architecture allows fast sampling of multiple channels using a single ADC, providing a low-cost solution. This design systematically approaches each analog circuit block to achieve a 16-bit settling for a full-scale input stage voltage and linearity for a 10-kHz sinusoidal input signal at each input channel. Detailed design considerations and component selection procedure can be found in the TI Precision Design [TIPD151](#), *16-Bit, 400-kSPS, 4-Channel Multiplexed Data-Acquisition System for High-Voltage Inputs with Lowest Distortion*.

### 9.2.3 Application Curve

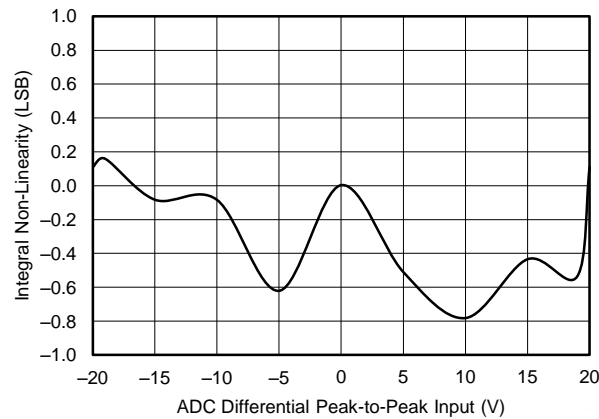

**Figure 43. ADC 16-Bit Linearity Error for the Multiplexed Data-Acquisition Block**

## MUX506, MUX507

SBAS803A –NOVEMBER 2016–REVISED NOVEMBER 2017

www.ti.com

### 10 Power Supply Recommendations

The MUX50x operates across a wide supply range of  $\pm 5$  V to  $\pm 18$  V (10 V to 36 V in single-supply mode). The devices also perform well with unsymmetric supplies such as  $V_{DD} = 12$  V and  $V_{SS} = -5$  V. For reliable operation, use a supply decoupling capacitor ranging between 0.1  $\mu$ F to 10  $\mu$ F at both the VDD and VSS pins to ground.

The on-resistance of the MUX50x varies with supply voltage, as illustrated in [Figure 44](#)

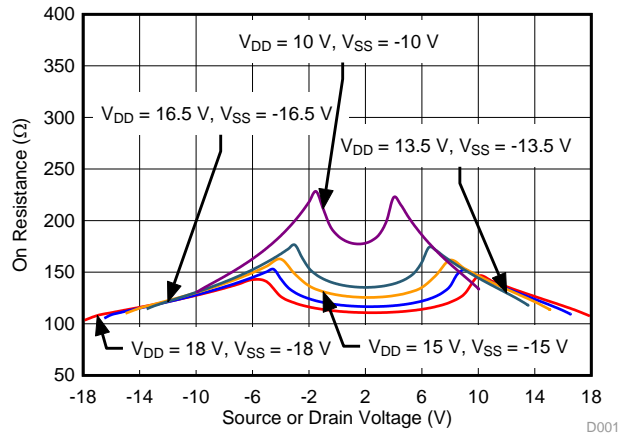

**Figure 44. On-Resistance Variation With Supply and Input Voltage**

## 11 Layout

### 11.1 Layout Guidelines

Figure 45 illustrates an example of a PCB layout with the MUX506IPW, and Figure 46 illustrates an example of a PCB layout with MUX507IPW.

Some key considerations are:

1. Decouple the VDD and VSS pins with a 0.1- $\mu$ F capacitor, placed as close to the pin as possible. Make sure that the capacitor voltage rating is sufficient for the  $V_{DD}$  and  $V_{SS}$  supplies.
2. Keep the input lines as short as possible. In case of the differential signal, make sure the A inputs and B inputs are as symmetric as possible.
3. Use a solid ground plane to help distribute heat and reduce electromagnetic interference (EMI) noise pickup.
4. Do not run sensitive analog traces in parallel with digital traces. Avoid crossing digital and analog traces if possible, and only make perpendicular crossings when necessary.

### 11.2 Layout Example

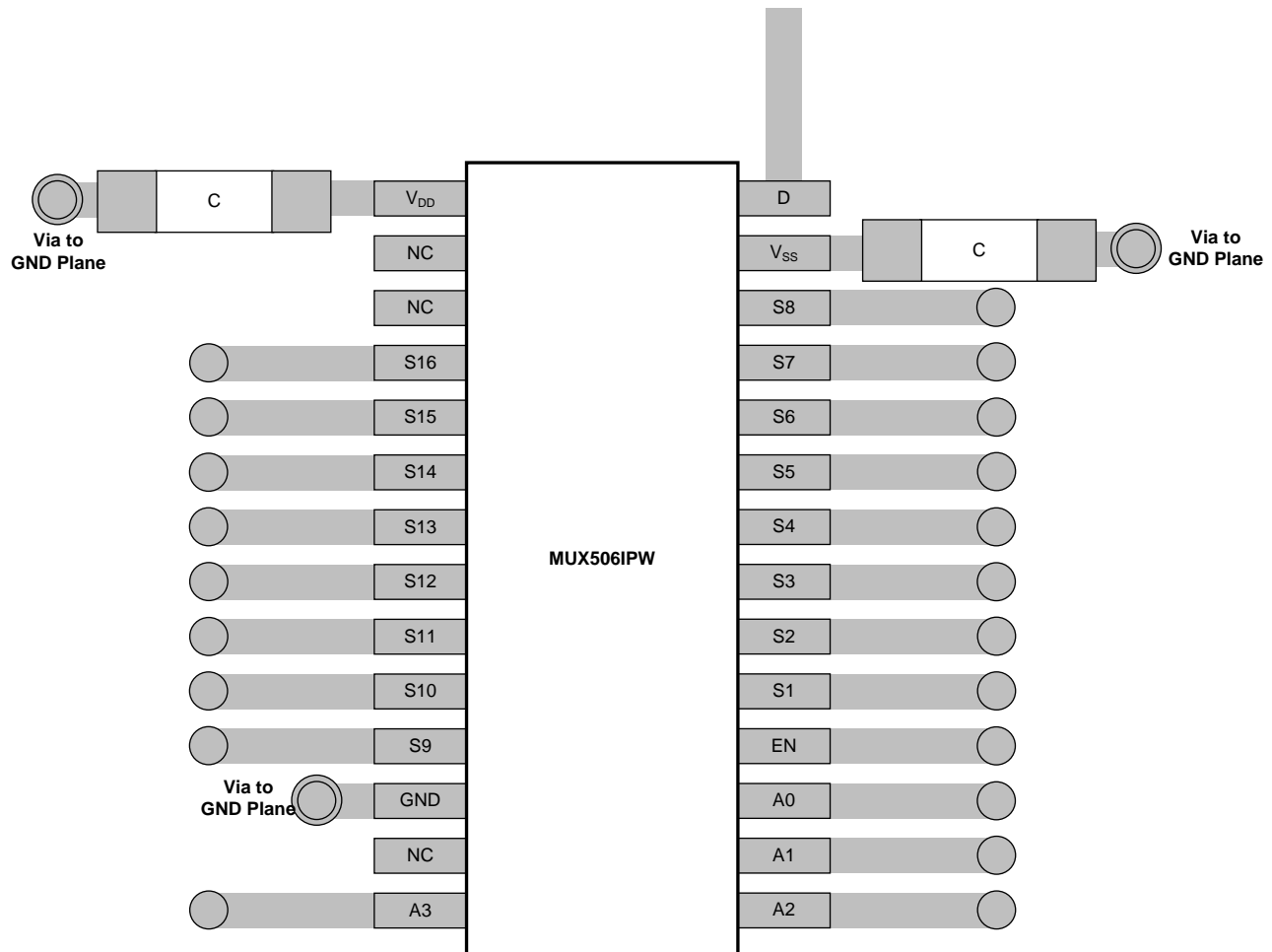

Figure 45. MUX506IPW Layout Example

**MUX506, MUX507**

SBAS803A –NOVEMBER 2016–REVISED NOVEMBER 2017

[www.ti.com](http://www.ti.com)

**Layout Example (continued)**

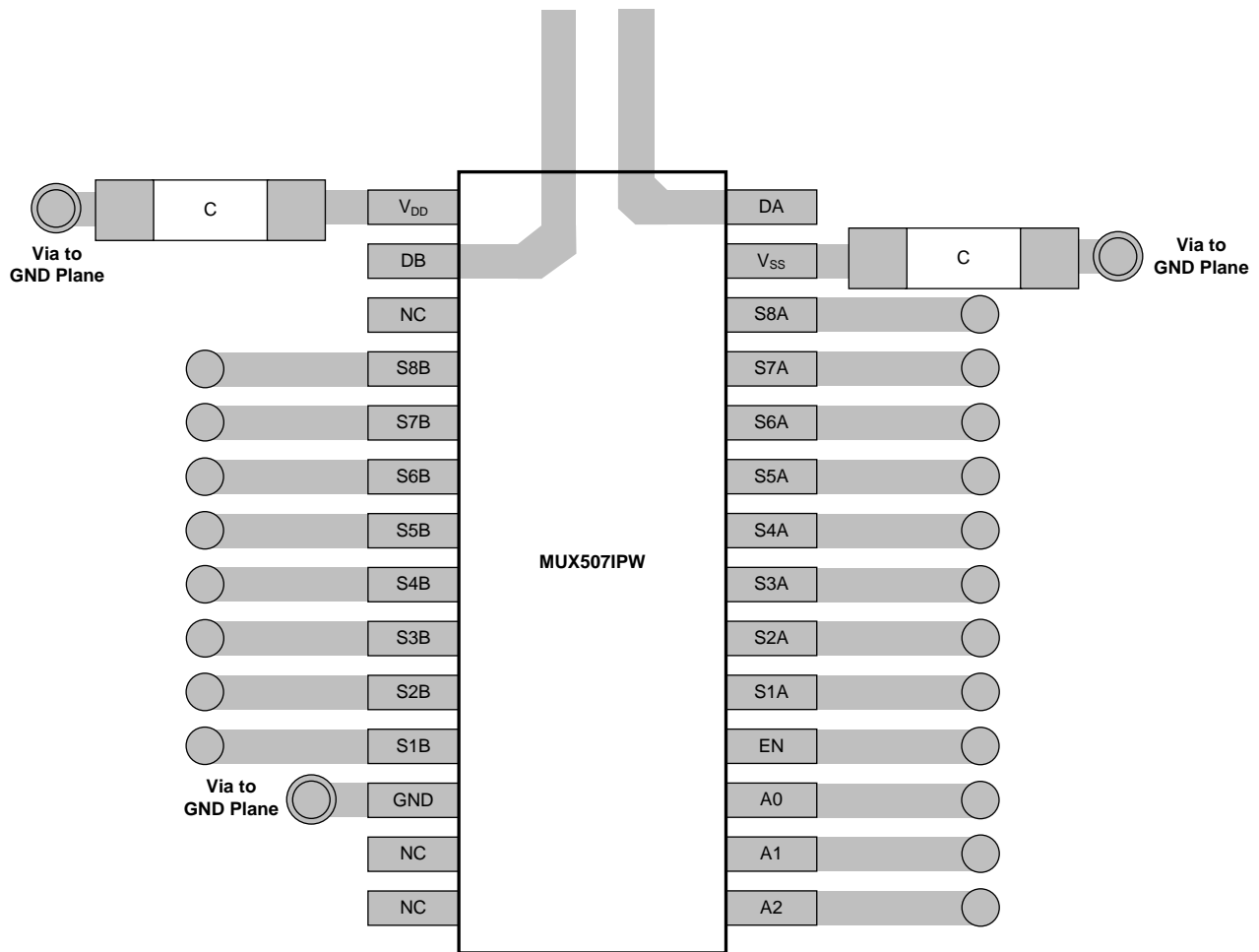

**Figure 46. MUX507IPW Layout Example**

## 12 Device and Documentation Support

### 12.1 Documentation Support

#### 12.1.1 Related Documentation

For related documentation see the following:

- [ADS8864 16-Bit, 400-kSPS, Serial Interface, microPower, Miniature, Single-Ended Input, SAR Analog-to-Digital Converter](#) (SBAS572)
- [OPAx192 36-V, Precision, Rail-to-Rail Input/Output, Low Offset Voltage, Low Input Bias Current Op Amp with e-trim](#) (SBOS620)
- [OPAx140 High-Precision, Low-Noise, Rail-to-Rail Output, 11-MHz JFET Op Amp](#) (SBOS498)

### 12.2 Related Links

The following table lists quick access links. Categories include technical documents, support and community resources, tools and software, and quick access to sample or buy.

**Table 3. Related Links**

| PARTS  | PRODUCT FOLDER             | SAMPLE & BUY               | TECHNICAL DOCUMENTS        | TOOLS & SOFTWARE           | SUPPORT & COMMUNITY        |
|--------|----------------------------|----------------------------|----------------------------|----------------------------|----------------------------|
| MUX506 | <a href="#">Click here</a> | <a href="#">Click here</a> | <a href="#">Click here</a> | <a href="#">Click here</a> | <a href="#">Click here</a> |
| MUX507 | <a href="#">Click here</a> | <a href="#">Click here</a> | <a href="#">Click here</a> | <a href="#">Click here</a> | <a href="#">Click here</a> |

### 12.3 Receiving Notification of Documentation Updates

To receive notification of documentation updates, navigate to the device product folder on ti.com. In the upper right corner, click on *Alert me* to register and receive a weekly digest of any product information that has changed. For change details, review the revision history included in any revised document.

### 12.4 Community Resources

The following links connect to TI community resources. Linked contents are provided "AS IS" by the respective contributors. They do not constitute TI specifications and do not necessarily reflect TI's views; see TI's [Terms of Use](#).

**TI E2E™ Online Community** *TI's Engineer-to-Engineer (E2E) Community*. Created to foster collaboration among engineers. At e2e.ti.com, you can ask questions, share knowledge, explore ideas and help solve problems with fellow engineers.

**Design Support** *TI's Design Support* Quickly find helpful E2E forums along with design support tools and contact information for technical support.

### 12.5 Trademarks

E2E is a trademark of Texas Instruments.  
All other trademarks are the property of their respective owners.

### 12.6 Electrostatic Discharge Caution



This integrated circuit can be damaged by ESD. Texas Instruments recommends that all integrated circuits be handled with appropriate precautions. Failure to observe proper handling and installation procedures can cause damage.

ESD damage can range from subtle performance degradation to complete device failure. Precision integrated circuits may be more susceptible to damage because very small parametric changes could cause the device not to meet its published specifications.

### 12.7 Glossary

[SLYZ022](#) — *TI Glossary*.

This glossary lists and explains terms, acronyms, and definitions.

**MUX506, MUX507**

SBAS803A –NOVEMBER 2016–REVISED NOVEMBER 2017

[www.ti.com](http://www.ti.com)

---

**13 Mechanical, Packaging, and Orderable Information**

The following pages include mechanical, packaging, and orderable information. This information is the most current data available for the designated devices. This data is subject to change without notice and revision of this document. For browser-based versions of this data sheet, refer to the left-hand navigation.

**PACKAGING INFORMATION**

| Orderable part number      | Status<br>(1) | Material type<br>(2) | Package   Pins  | Package qty   Carrier | RoHS<br>(3) | Lead finish/<br>Ball material<br>(4) | MSL rating/<br>Peak reflow<br>(5) | Op temp (°C) | Part marking<br>(6) |
|----------------------------|---------------|----------------------|-----------------|-----------------------|-------------|--------------------------------------|-----------------------------------|--------------|---------------------|
| <a href="#">MUX506IDWR</a> | Active        | Production           | SOIC (DW)   28  | 1000   LARGE T&R      | Yes         | NIPDAU                               | Level-3-260C-168 HR               | -40 to 125   | MUX506DA            |
| MUX506IDWR.B               | Active        | Production           | SOIC (DW)   28  | 1000   LARGE T&R      | Yes         | NIPDAU                               | Level-3-260C-168 HR               | -40 to 125   | MUX506DA            |
| <a href="#">MUX506IPW</a>  | Active        | Production           | TSSOP (PW)   28 | 50   TUBE             | Yes         | NIPDAU                               | Level-3-260C-168 HR               | -40 to 125   | MUX506A             |
| MUX506IPW.B                | Active        | Production           | TSSOP (PW)   28 | 50   TUBE             | Yes         | NIPDAU                               | Level-3-260C-168 HR               | -40 to 125   | MUX506A             |
| <a href="#">MUX506IPWR</a> | Active        | Production           | TSSOP (PW)   28 | 2000   LARGE T&R      | Yes         | NIPDAU                               | Level-3-260C-168 HR               | -40 to 125   | MUX506A             |
| MUX506IPWR.B               | Active        | Production           | TSSOP (PW)   28 | 2000   LARGE T&R      | Yes         | NIPDAU                               | Level-3-260C-168 HR               | -40 to 125   | MUX506A             |
| MUX506IPWRG4               | Active        | Production           | TSSOP (PW)   28 | 2000   LARGE T&R      | Yes         | NIPDAU                               | Level-3-260C-168 HR               | -40 to 125   | MUX506A             |
| MUX506IPWRG4.B             | Active        | Production           | TSSOP (PW)   28 | 2000   LARGE T&R      | Yes         | NIPDAU                               | Level-3-260C-168 HR               | -40 to 125   | MUX506A             |
| <a href="#">MUX507IDWR</a> | Active        | Production           | SOIC (DW)   28  | 1000   LARGE T&R      | Yes         | NIPDAU                               | Level-3-260C-168 HR               | -40 to 125   | MUX507DA            |
| MUX507IDWR.B               | Active        | Production           | SOIC (DW)   28  | 1000   LARGE T&R      | Yes         | NIPDAU                               | Level-3-260C-168 HR               | -40 to 125   | MUX507DA            |
| <a href="#">MUX507IPW</a>  | Active        | Production           | TSSOP (PW)   28 | 50   TUBE             | Yes         | NIPDAU                               | Level-3-260C-168 HR               | -40 to 125   | MUX507A             |
| MUX507IPW.B                | Active        | Production           | TSSOP (PW)   28 | 50   TUBE             | Yes         | NIPDAU                               | Level-3-260C-168 HR               | -40 to 125   | MUX507A             |
| <a href="#">MUX507IPWR</a> | Active        | Production           | TSSOP (PW)   28 | 2000   LARGE T&R      | Yes         | NIPDAU                               | Level-3-260C-168 HR               | -40 to 125   | MUX507A             |
| MUX507IPWR.B               | Active        | Production           | TSSOP (PW)   28 | 2000   LARGE T&R      | Yes         | NIPDAU                               | Level-3-260C-168 HR               | -40 to 125   | MUX507A             |
| MUX507IPWRG4               | Active        | Production           | TSSOP (PW)   28 | 2000   LARGE T&R      | Yes         | NIPDAU                               | Level-3-260C-168 HR               | -40 to 125   | MUX507A             |
| MUX507IPWRG4.B             | Active        | Production           | TSSOP (PW)   28 | 2000   LARGE T&R      | Yes         | NIPDAU                               | Level-3-260C-168 HR               | -40 to 125   | MUX507A             |

(1) **Status:** For more details on status, see our [product life cycle](#).

(2) **Material type:** When designated, preproduction parts are prototypes/experimental devices, and are not yet approved or released for full production. Testing and final process, including without limitation quality assurance, reliability performance testing, and/or process qualification, may not yet be complete, and this item is subject to further changes or possible discontinuation. If available for ordering, purchases will be subject to an additional waiver at checkout, and are intended for early internal evaluation purposes only. These items are sold without warranties of any kind.

(3) **RoHS values:** Yes, No, RoHS Exempt. See the [TI RoHS Statement](#) for additional information and value definition.

(4) **Lead finish/Ball material:** Parts may have multiple material finish options. Finish options are separated by a vertical ruled line. Lead finish/Ball material values may wrap to two lines if the finish value exceeds the maximum column width.

(5) **MSL rating/Peak reflow:** The moisture sensitivity level ratings and peak solder (reflow) temperatures. In the event that a part has multiple moisture sensitivity ratings, only the lowest level per JEDEC standards is shown. Refer to the shipping label for the actual reflow temperature that will be used to mount the part to the printed circuit board.

**(6) Part marking:** There may be an additional marking, which relates to the logo, the lot trace code information, or the environmental category of the part.

Multiple part markings will be inside parentheses. Only one part marking contained in parentheses and separated by a "-" will appear on a part. If a line is indented then it is a continuation of the previous line and the two combined represent the entire part marking for that device.

**Important Information and Disclaimer:**The information provided on this page represents TI's knowledge and belief as of the date that it is provided. TI bases its knowledge and belief on information provided by third parties, and makes no representation or warranty as to the accuracy of such information. Efforts are underway to better integrate information from third parties. TI has taken and continues to take reasonable steps to provide representative and accurate information but may not have conducted destructive testing or chemical analysis on incoming materials and chemicals. TI and TI suppliers consider certain information to be proprietary, and thus CAS numbers and other limited information may not be available for release.

In no event shall TI's liability arising out of such information exceed the total purchase price of the TI part(s) at issue in this document sold by TI to Customer on an annual basis.

## TAPE AND REEL INFORMATION

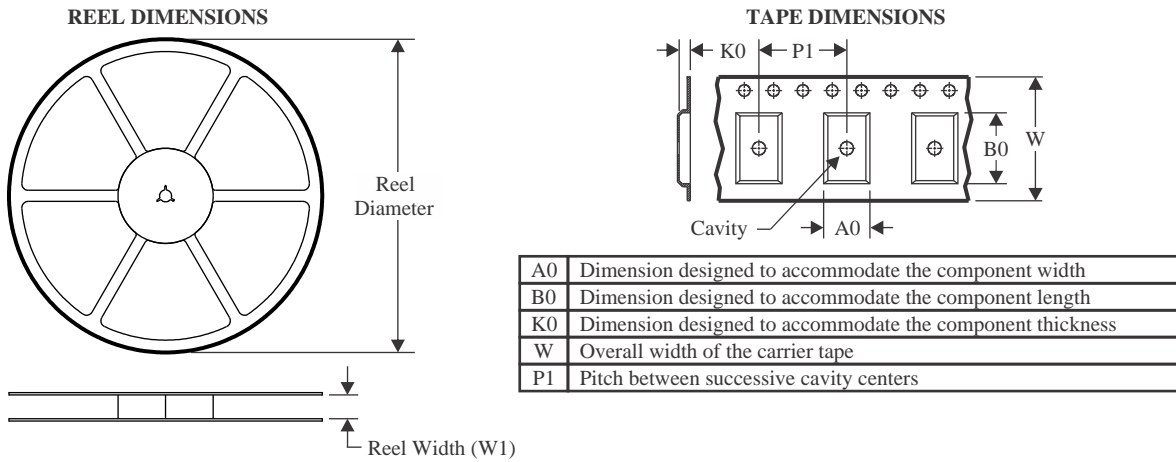

### QUADRANT ASSIGNMENTS FOR PIN 1 ORIENTATION IN TAPE

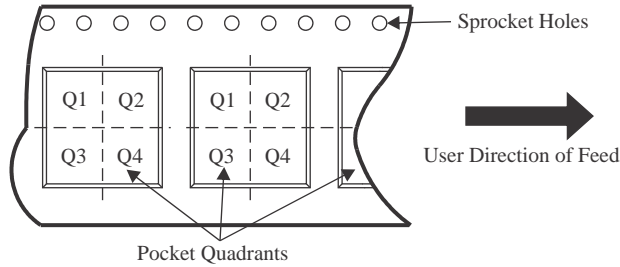

\*All dimensions are nominal

| Device       | Package Type | Package Drawing | Pins | SPQ  | Reel Diameter (mm) | Reel Width W1 (mm) | A0 (mm) | B0 (mm) | K0 (mm) | P1 (mm) | W (mm) | Pin1 Quadrant |
|--------------|--------------|-----------------|------|------|--------------------|--------------------|---------|---------|---------|---------|--------|---------------|
| MUX506IDWR   | SOIC         | DW              | 28   | 1000 | 330.0              | 32.4               | 11.35   | 18.67   | 3.1     | 16.0    | 32.0   | Q1            |
| MUX506IPWR   | TSSOP        | PW              | 28   | 2000 | 330.0              | 16.4               | 6.9     | 10.2    | 1.8     | 12.0    | 16.0   | Q1            |
| MUX506IPWRG4 | TSSOP        | PW              | 28   | 2000 | 330.0              | 16.4               | 6.9     | 10.2    | 1.8     | 12.0    | 16.0   | Q1            |
| MUX507IDWR   | SOIC         | DW              | 28   | 1000 | 330.0              | 32.4               | 11.35   | 18.67   | 3.1     | 16.0    | 32.0   | Q1            |
| MUX507IPWR   | TSSOP        | PW              | 28   | 2000 | 330.0              | 16.4               | 6.9     | 10.2    | 1.8     | 12.0    | 16.0   | Q1            |
| MUX507IPWRG4 | TSSOP        | PW              | 28   | 2000 | 330.0              | 16.4               | 6.9     | 10.2    | 1.8     | 12.0    | 16.0   | Q1            |

## TAPE AND REEL BOX DIMENSIONS

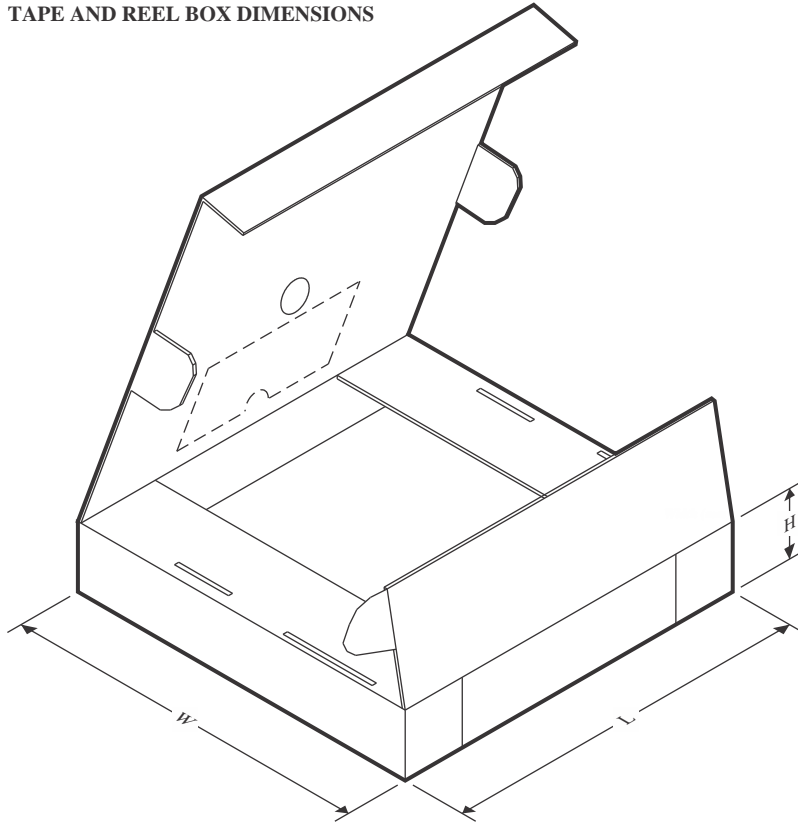

\*All dimensions are nominal

| Device       | Package Type | Package Drawing | Pins | SPQ  | Length (mm) | Width (mm) | Height (mm) |
|--------------|--------------|-----------------|------|------|-------------|------------|-------------|
| MUX506IDWR   | SOIC         | DW              | 28   | 1000 | 350.0       | 350.0      | 66.0        |
| MUX506IPWR   | TSSOP        | PW              | 28   | 2000 | 350.0       | 350.0      | 43.0        |
| MUX506IPWRG4 | TSSOP        | PW              | 28   | 2000 | 350.0       | 350.0      | 43.0        |
| MUX507IDWR   | SOIC         | DW              | 28   | 1000 | 350.0       | 350.0      | 66.0        |
| MUX507IPWR   | TSSOP        | PW              | 28   | 2000 | 350.0       | 350.0      | 43.0        |
| MUX507IPWRG4 | TSSOP        | PW              | 28   | 2000 | 350.0       | 350.0      | 43.0        |

## TUBE

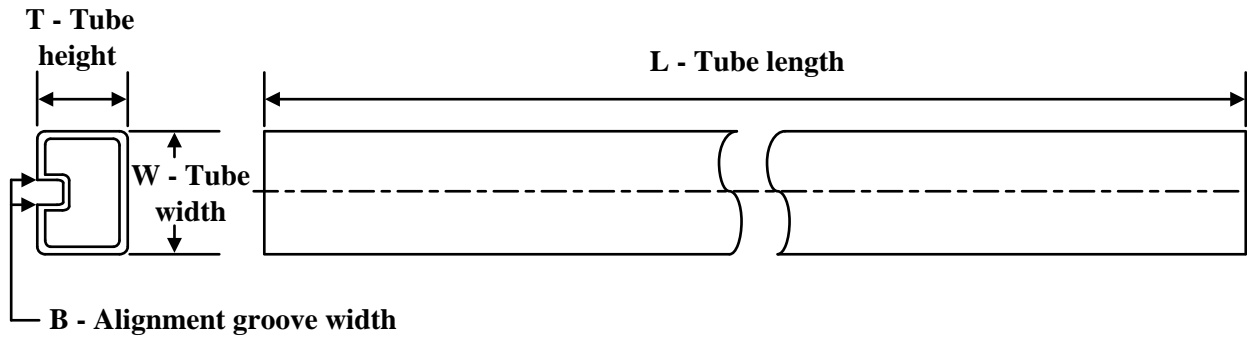

\*All dimensions are nominal

| Device      | Package Name | Package Type | Pins | SPQ | L (mm) | W (mm) | T (μm) | B (mm) |
|-------------|--------------|--------------|------|-----|--------|--------|--------|--------|
| MUX506IPW   | PW           | TSSOP        | 28   | 50  | 530    | 10.2   | 3600   | 3.5    |
| MUX506IPW.B | PW           | TSSOP        | 28   | 50  | 530    | 10.2   | 3600   | 3.5    |
| MUX507IPW   | PW           | TSSOP        | 28   | 50  | 530    | 10.2   | 3600   | 3.5    |
| MUX507IPW.B | PW           | TSSOP        | 28   | 50  | 530    | 10.2   | 3600   | 3.5    |

MECHANICAL DATA

DW (R-PDSO-G28)

PLASTIC SMALL OUTLINE

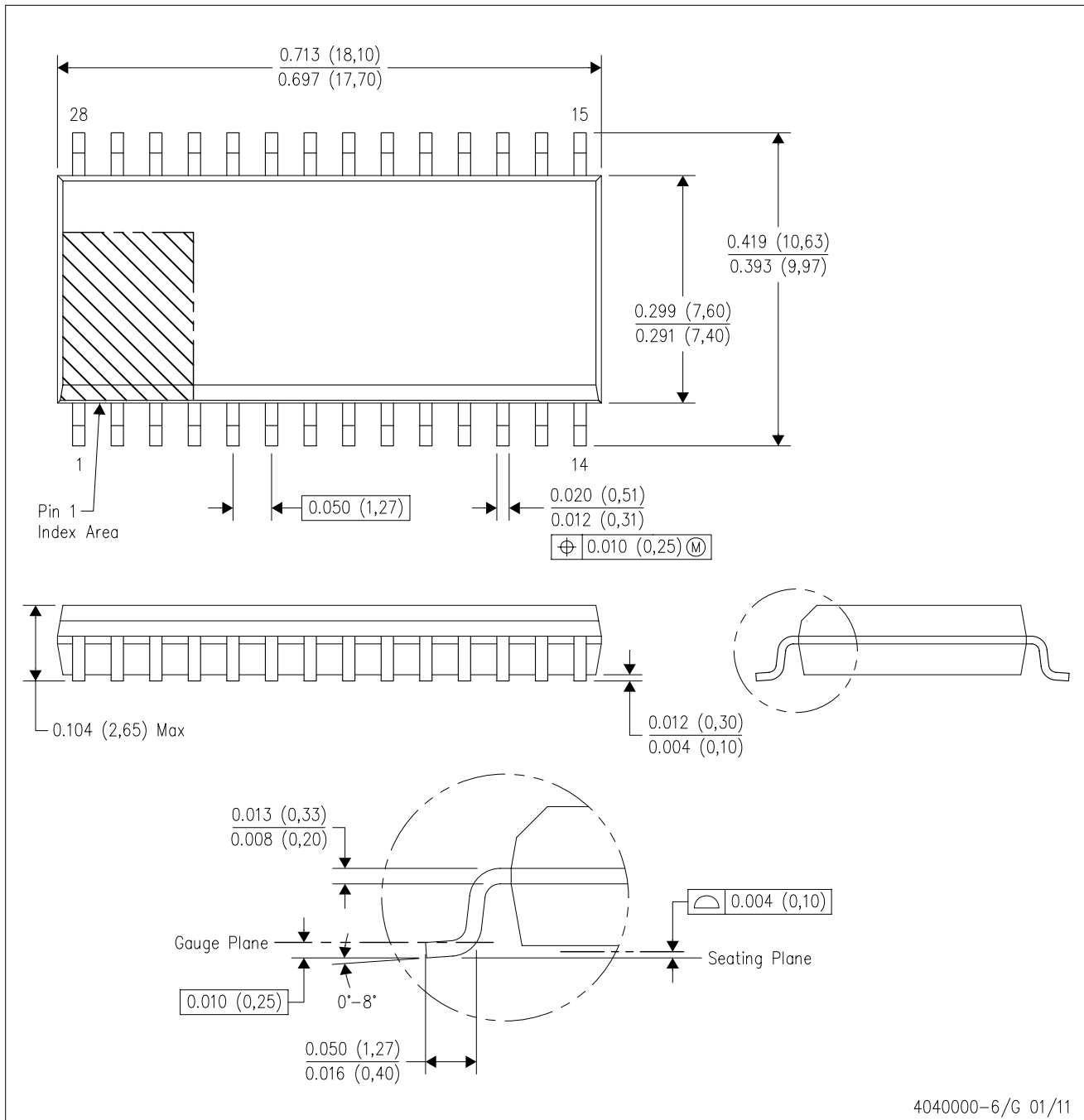

4040000-6/G 01/11

- NOTES:
- A. All linear dimensions are in inches (millimeters). Dimensioning and tolerancing per ASME Y14.5M-1994.
  - B. This drawing is subject to change without notice.
  - C. Body dimensions do not include mold flash or protrusion not to exceed 0.006 (0,15).
  - D. Falls within JEDEC MS-013 variation AE.

LAND PATTERN DATA

DW (R-PDSO-G28)

PLASTIC SMALL OUTLINE

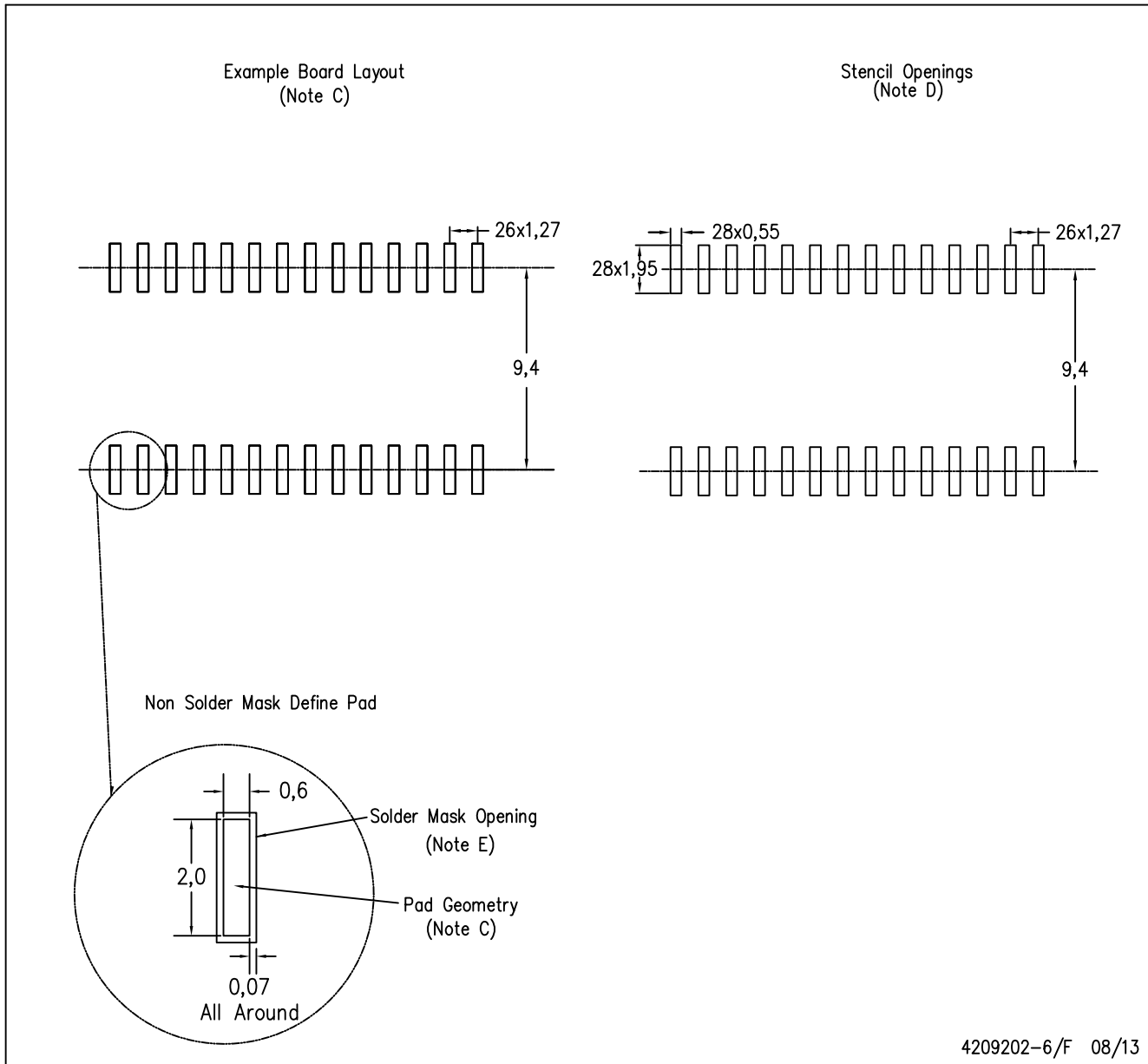

- NOTES:
- A. All linear dimensions are in millimeters.
  - B. This drawing is subject to change without notice.
  - C. Refer to IPC7351 for alternate board design.
  - D. Laser cutting apertures with trapezoidal walls and also rounding corners will offer better paste release. Customers should contact their board assembly site for stencil design recommendations. Refer to IPC-7525
  - E. Customers should contact their board fabrication site for solder mask tolerances between and around signal pads.

**MECHANICAL DATA**

PW (R-PDSO-G28)

PLASTIC SMALL OUTLINE

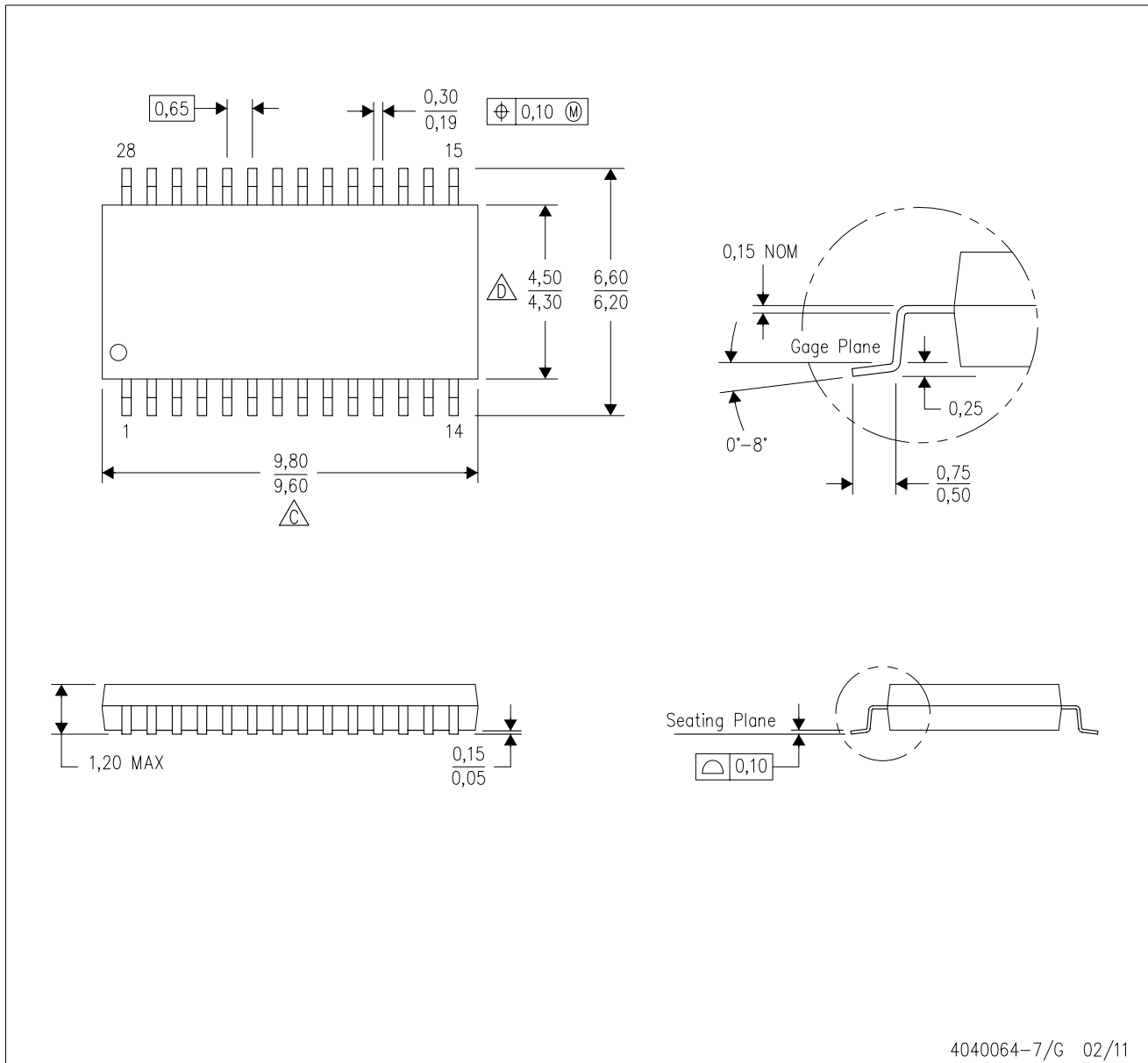

4040064-7/G 02/11

- NOTES:
- A. All linear dimensions are in millimeters. Dimensioning and tolerancing per ASME Y14.5M-1994.
  - B. This drawing is subject to change without notice.
  - C. Body length does not include mold flash, protrusions, or gate burrs. Mold flash, protrusions, or gate burrs shall not exceed 0,15 each side.
  - D. Body width does not include interlead flash. Interlead flash shall not exceed 0,25 each side.
  - E. Falls within JEDEC MO-153

## IMPORTANT NOTICE AND DISCLAIMER

TI PROVIDES TECHNICAL AND RELIABILITY DATA (INCLUDING DATASHEETS), DESIGN RESOURCES (INCLUDING REFERENCE DESIGNS), APPLICATION OR OTHER DESIGN ADVICE, WEB TOOLS, SAFETY INFORMATION, AND OTHER RESOURCES "AS IS" AND WITH ALL FAULTS, AND DISCLAIMS ALL WARRANTIES, EXPRESS AND IMPLIED, INCLUDING WITHOUT LIMITATION ANY IMPLIED WARRANTIES OF MERCHANTABILITY, FITNESS FOR A PARTICULAR PURPOSE OR NON-INFRINGEMENT OF THIRD PARTY INTELLECTUAL PROPERTY RIGHTS.

These resources are intended for skilled developers designing with TI products. You are solely responsible for (1) selecting the appropriate TI products for your application, (2) designing, validating and testing your application, and (3) ensuring your application meets applicable standards, and any other safety, security, regulatory or other requirements.

These resources are subject to change without notice. TI grants you permission to use these resources only for development of an application that uses the TI products described in the resource. Other reproduction and display of these resources is prohibited. No license is granted to any other TI intellectual property right or to any third party intellectual property right. TI disclaims responsibility for, and you fully indemnify TI and its representatives against any claims, damages, costs, losses, and liabilities arising out of your use of these resources.

TI's products are provided subject to [TI's Terms of Sale](#), [TI's General Quality Guidelines](#), or other applicable terms available either on [ti.com](http://ti.com) or provided in conjunction with such TI products. TI's provision of these resources does not expand or otherwise alter TI's applicable warranties or warranty disclaimers for TI products. Unless TI explicitly designates a product as custom or customer-specified, TI products are standard, catalog, general purpose devices.

TI objects to and rejects any additional or different terms you may propose.

Copyright © 2025, Texas Instruments Incorporated

Last updated 10/2025

## OUR CERTIFICATE

DiGi provide top-quality products and perfect service for customer worldwide through standardization, technological innovation and continuous improvement. DiGi through third-party certification, we stricly control the quality of products and services. Welcome your RFQ to

Email: [Info@DiGi-Electronics.com](mailto:Info@DiGi-Electronics.com)



Tel: +00 852-30501935

RFQ Email: [Info@DiGi-Electronics.com](mailto:Info@DiGi-Electronics.com)

DiGi is a global authorized distributor of electronic components.