

SN74ACT7802-25FN Datasheet



<https://www.DiGi-Electronics.com>

DiGi Electronics Part Number	SN74ACT7802-25FN-DG
Manufacturer	Texas Instruments
Manufacturer Product Number	SN74ACT7802-25FN
Description	IC FIFO ASYNC 1KX18 30NS 68PLCC
Detailed Description	Asynchronous FIFO 18K (1K x 18) Uni-Directional 40 MHz 30ns 68-PLCC (24.23x24.23)

This model SN74ACT7802-25FN is available at DiGi Electronics.

DiGi Electronics offers a global database of semiconductor and electronic component datasheets.

We welcome your inquiries regarding pricing, lead time, or other product-related questions.

 [Request a Quote](#)

 [Datasheet Search](#)



Tel: +00 852-30501935

RFQ Email: Info@DiGi-Electronics.com

DiGi is a global authorized distributor of electronic components.

Purchase and inquiry

Manufacturer Product Number:

SN74ACT7802-25FN

Series:

74ACT

DiGi-Electronics Programmable:

Not Verified

Function:

Asynchronous

Access Time:

30ns

Current - Supply (Max):

400µA

Expansion Type:

Width

Retransmit Capability:

No

Operating Temperature:

0°C ~ 70°C

Package / Case:

68-LCC (J-Lead)

Base Product Number:

74ACT7802

Manufacturer:

Texas Instruments

Product Status:

Obsolete

Memory Size:

18K (1K x 18)

Data Rate:

40MHz

Voltage - Supply:

4.5 V ~ 5.5 V

Bus Directional:

Uni-Directional

Programmable Flags Support:

Yes

FWFT Support:

No

Mounting Type:

Surface Mount

Supplier Device Package:

68-PLCC (24.23x24.23)

Environmental & Export classification

RoHS Status:

ROHS3 Compliant

REACH Status:

REACH Unaffected

HTSUS:

8542.39.0001

Moisture Sensitivity Level (MSL):

3 (168 Hours)

ECCN:

EAR99

SN74ACT7802

1024 × 18 STROBED FIRST-IN, FIRST-OUT MEMORY

SCAS187D – AUGUST 1990 – REVISED APRIL 1998

- Member of the Texas Instruments Widebus™ Family
- Low-Power Advanced CMOS Technology
- Load and Unload Clocks Can Be Asynchronous or Coincident
- 1024 Words × 18 Bits
- Programmable Almost-Full/Almost-Empty Flag
- Empty, Full, and Half-Full Flags
- Fast Access Times of 30 ns With a 50-pF Load
- Fall-Through Time Is 20 ns Typical
- Data Rates up to 40 MHz
- High-Output Drive for Direct Bus Interface
- 3-State Outputs
- Package Options Include 68-Pin (FN) and 80-Pin Thin Quad Flat (PN) Packages

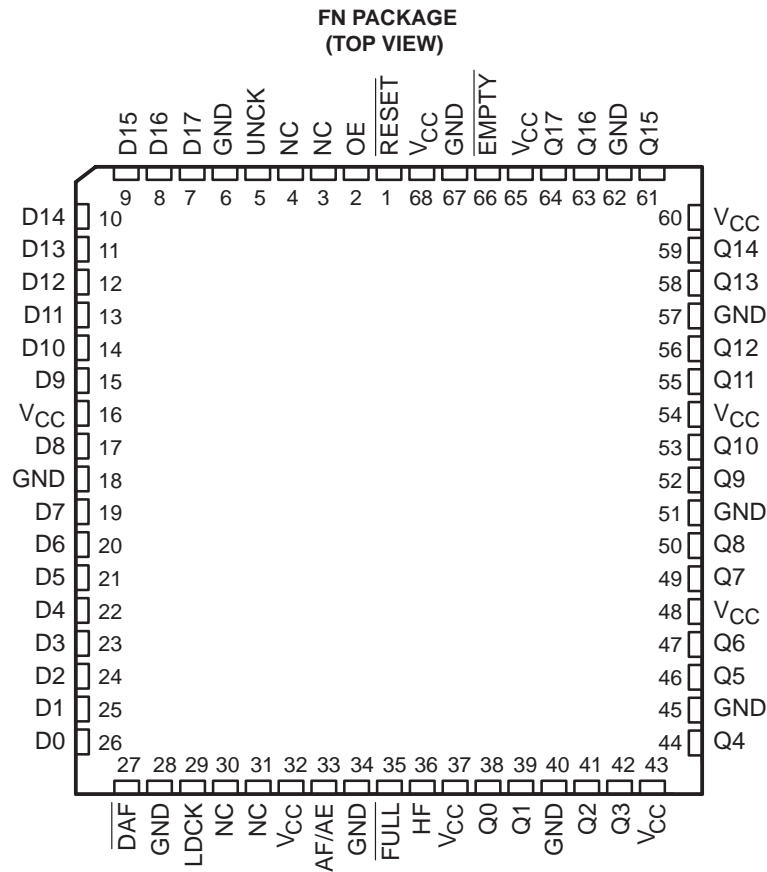

Please be aware that an important notice concerning availability, standard warranty, and use in critical applications of Texas Instruments semiconductor products and disclaimers thereto appears at the end of this data sheet.

Widebus is a trademark of Texas Instruments Incorporated.

PRODUCTION DATA information is current as of publication date. Products conform to specifications per the terms of Texas Instruments standard warranty. Production processing does not necessarily include testing of all parameters.

 **TEXAS
INSTRUMENTS**

POST OFFICE BOX 655303 • DALLAS, TEXAS 75265

Copyright © 1998, Texas Instruments Incorporated

SN74ACT7802**1024 × 18 STROBED FIRST-IN, FIRST-OUT MEMORY**

SCAS187D – AUGUST 1990 – REVISED APRIL 1998

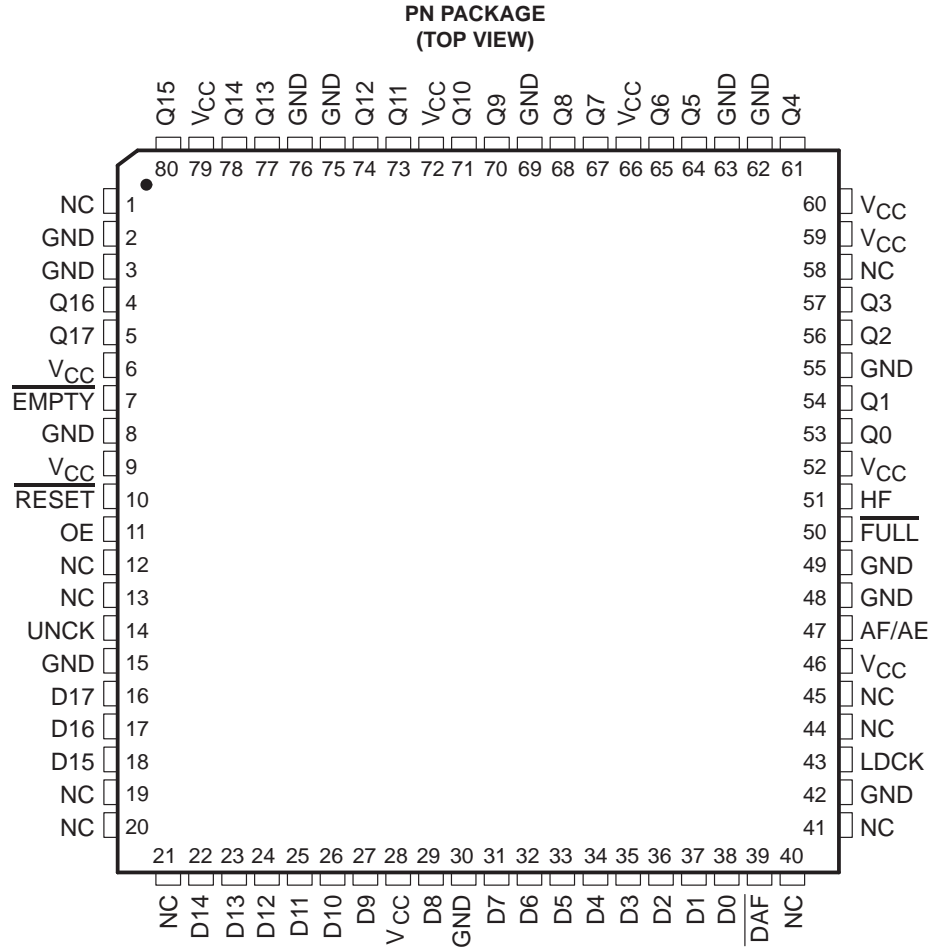

NC – No internal connection

description

A FIFO memory is a storage device that allows data to be written into and read from its array at independent data rates. The SN74ACT7802 is a 1024-word by 18-bit FIFO for high-speed applications. It processes data in a bit-parallel format at rates up to 40 MHz and access times of 30 ns.

Data is written into the FIFO memory on a low-to-high transition on the load-clock (LDCK) input and is read out on a low-to-high transition on the unload-clock (UNCK) input. The memory is full when the number of words clocked in exceeds by 1024 the number of words clocked out. When the memory is full, LDCK has no effect on the data in the memory; when the memory is empty, UNCK has no effect.

A low level on the reset ($\overline{\text{RESET}}$) input resets the FIFO internal clock stack pointers and sets full ($\overline{\text{FULL}}$) high, almost full/almost empty (AF/AE) high, half full (HF) low, and empty ($\overline{\text{EMPTY}}$) low. The Q outputs are not reset to any specific logic level. The FIFO must be reset upon power up. The Q outputs are noninverting and are in the high-impedance state when the output-enable (OE) input is low.

When writing to the FIFO after a reset pulse or when the FIFO is empty, the first active transition on LDCK drives $\overline{\text{EMPTY}}$ high and causes the first word written to the FIFO to appear on the Q outputs. An active transition on UNCK is not required to read the first word written to the FIFO. Each subsequent read from the FIFO requires an active transition on UNCK.

The SN74ACT7802 can be cascaded in the word-width direction but not in the word-depth direction.

The SN74ACT7802 is characterized for operation from 0°C to 70°C.



1024 × 18 STROBED FIRST-IN, FIRST-OUT MEMORY

SCAS187D – AUGUST 1990 – REVISED APRIL 1998

logic symbol†

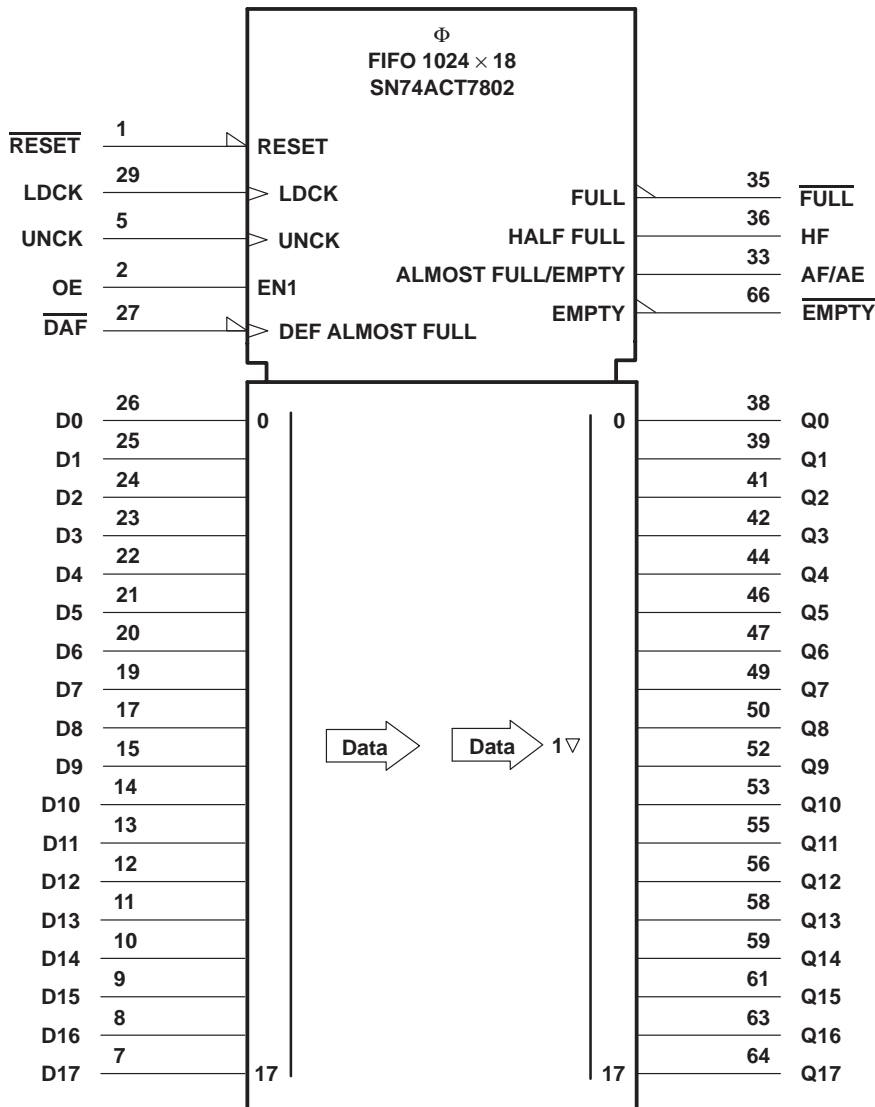

† This symbol is in accordance with ANSI/IEEE Std 91-1984 and IEC Publication 617-12. Pin numbers shown are for the FN package.

SN74ACT7802**1024 × 18 STROBED FIRST-IN, FIRST-OUT MEMORY**

SCAS187D – AUGUST 1990 – REVISED APRIL 1998

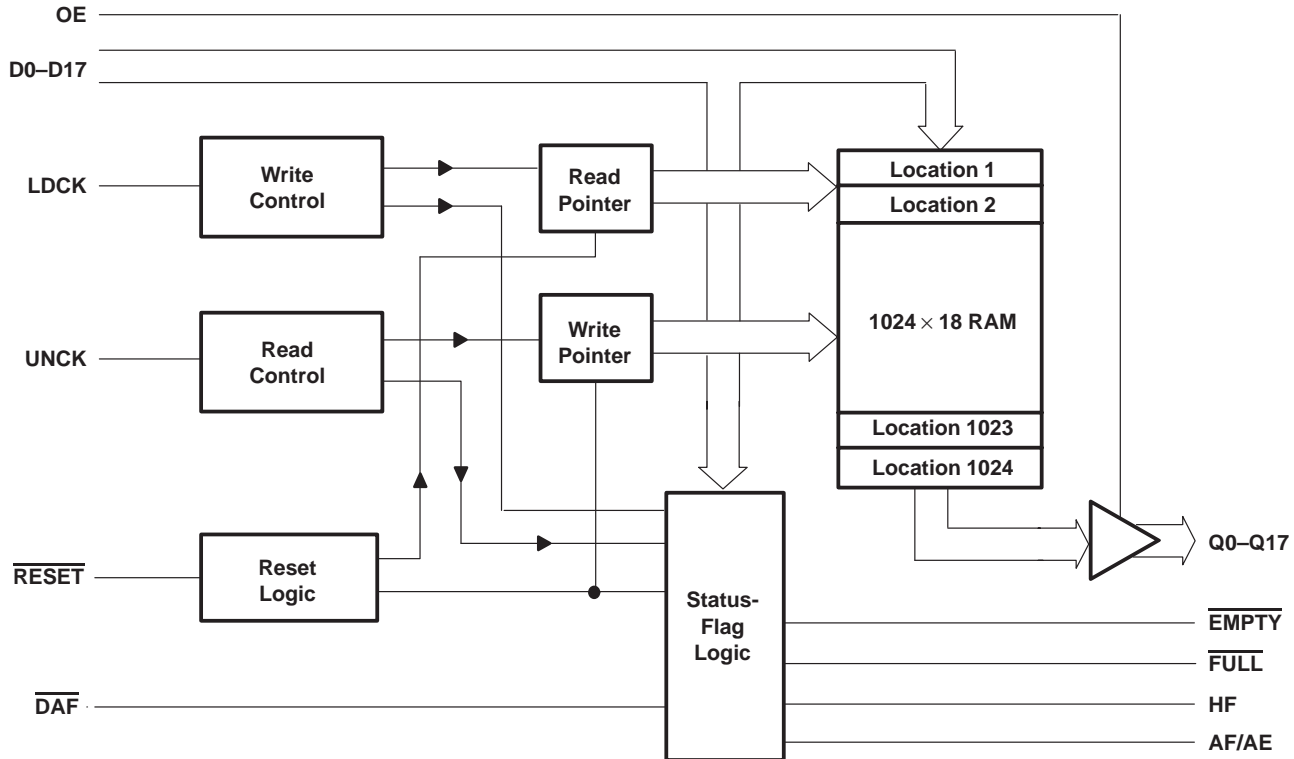
functional block diagram**Terminal Functions**

TERMINAL NAME	NO.†	I/O	DESCRIPTION
AF/AE	33	O	Almost-full/almost-empty flag. Depth-offset values can be programmed for AF/AE, or the default value of 256 can be used for the almost-empty almost-full offset (X). AF/AE is high when memory contains X or fewer words or (1024 – X) or more words. AF/AE is high after reset.
$\overline{\text{DAF}}$	27	I	Define almost-full flag. The high-to-low transition of $\overline{\text{DAF}}$ stores the binary value of data inputs as the AF/AE offset value (X). With DAF held low, a low pulse on RESET defines AF/AE using X.
D0–D17	7–15, 17, 19–26	I	18-bit data input port
$\overline{\text{EMPTY}}$	66	O	Empty flag. $\overline{\text{EMPTY}}$ is low when the FIFO is empty. A FIFO reset also causes $\overline{\text{EMPTY}}$ to go low.
$\overline{\text{FULL}}$	35	O	Full flag. $\overline{\text{FULL}}$ is low when the FIFO is full. A FIFO reset causes $\overline{\text{FULL}}$ to go high.
HF	36	O	Half-full flag. HF is high when the FIFO memory contains 512 or more words. HF is low after reset.
LDCK	29	I	Load clock. Data is written to the FIFO on the rising edge of LDCK when $\overline{\text{FULL}}$ is high.
OE	2	I	Output enable. When OE is low, the data outputs are in the high-impedance state.
Q0–Q17	38–39, 41–42, 44, 46–47, 49–50, 52–53, 55–56, 58–59, 61, 63–64	O	18-bit data-output port
$\overline{\text{RESET}}$	1	I	Reset. A low level on $\overline{\text{RESET}}$ resets the FIFO and drives AF/AE and $\overline{\text{FULL}}$ high and HF and $\overline{\text{EMPTY}}$ low.
UNCK	5	I	Unload clock. Data is read from the FIFO on the rising edge of UNCK when $\overline{\text{EMPTY}}$ is high.

† Terminal numbers listed are for the FN package.

offset value values for AF/AE

The FIFO memory status is monitored by the $\overline{\text{FULL}}$, $\overline{\text{EMPTY}}$, HF, and AF/AE flags. The $\overline{\text{FULL}}$ output is low when the memory is full; the $\overline{\text{EMPTY}}$ output is low when the memory is empty. The HF output is high when the memory contains 512 or more words and low when it contains fewer than 512 words. The level of the AF/AE flag is determined by both the number of words in the FIFO and a user-definable offset X. AF/AE is high when the FIFO is almost full or almost empty, i.e., when it contains X or fewer words or $(1024 - X)$ or more words. The AF/AE offset value is either user-defined or the default value of 256; it is programmed during each reset cycle as follows:

user-defined X:

Take $\overline{\text{DAF}}$ from high to low.

If $\overline{\text{RESET}}$ is not already low, take $\overline{\text{RESET}}$ low.

With $\overline{\text{DAF}}$ held low, take $\overline{\text{RESET}}$ high. This defines the AF/AE flag using X.

default X:

To redefine the AF/AE flag using the default value of $X = 256$, hold $\overline{\text{DAF}}$ high during the reset cycle.

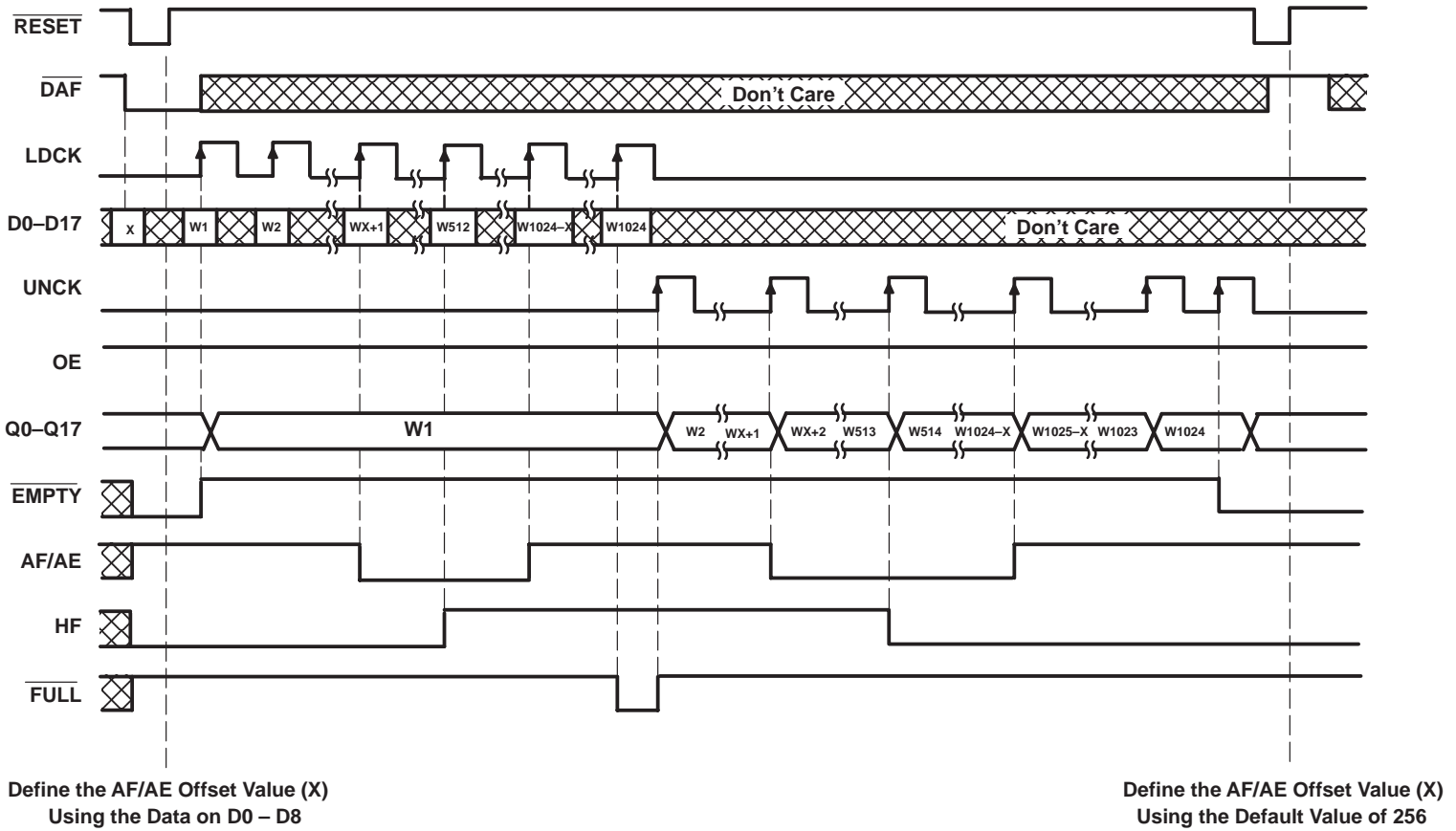

Figure 1. Write, Read, and Flag Timing Reference

absolute maximum ratings over operating free-air temperature range (unless otherwise noted)†

Supply voltage range, V_{CC}	–0.5 V to 7 V
Input voltage range, V_I	–0.5 V to 7 V
Voltage range applied to a disabled 3-state output	–0.5 V to 5.5 V
Package thermal impedance, θ_{JA} (see Note 1): FN package	39°C/W
PN package	62°C/W
Storage temperature range, T_{stg}	–65°C to 150°C

† Stresses beyond those listed under “absolute maximum ratings” may cause permanent damage to the device. These are stress ratings only, and functional operation of the device at these or any other conditions beyond those indicated under “recommended operating conditions” is not implied. Exposure to absolute-maximum-rated conditions for extended periods may affect device reliability.

NOTE 1: The package thermal impedance is calculated in accordance with JESD 51.

recommended operating conditions

		'ACT7802-25		'ACT7802-40		'ACT7802-60		UNIT
		MIN	MAX	MIN	MAX	MIN	MAX	
V_{CC}	Supply voltage	4.5	5.5	4.5	5.5	4.5	5.5	V
V_{IH}	High-level input voltage	2		2		2		V
V_{IL}	Low-level input voltage		0.8		0.8		0.8	V
I_{OH}	High-level output current		–8		–8		–8	mA
I_{OL}	Low-level output current		16		16		16	mA
T_A	Operating free-air temperature	0	70	0	70	0	70	°C

electrical characteristics over recommended operating free-air temperature range (unless otherwise noted)

PARAMETER	TEST CONDITIONS		MIN	TYP‡	MAX	UNIT
V_{OH}	$V_{CC} = 4.5$ V,	$I_{OH} = -8$ mA	2.4			V
V_{OL}	$V_{CC} = 4.5$ V,	$I_{OL} = 16$ mA			0.5	V
I_I	$V_{CC} = 5.5$ V,	$V_I = V_{CC}$ or 0			±5	μA
I_{OZ}	$V_{CC} = 5.5$ V,	$V_O = V_{CC}$ or 0			±5	μA
I_{CC}^{\S}	$V_I = V_{CC} - 0.2$ V or 0				400	μA
ΔI_{CC}^{\S}	$V_{CC} = 5.5$ V,	One input at 3.4 V, Other inputs at V_{CC} or GND			1	mA
C_i	$V_I = 0$,	$f = 1$ MHz		4		pF
C_o	$V_O = 0$,	$f = 1$ MHz		8		pF

‡ All typical values are at $V_{CC} = 5$ V, $T_A = 25^\circ\text{C}$.

§ I_{CC} tested with outputs open

SN74ACT7802

1024 × 18 STROBED FIRST-IN, FIRST-OUT MEMORY

SCAS187D – AUGUST 1990 – REVISED APRIL 1998

timing requirements over recommended operating conditions (see Figures 1 and 2)

		'ACT7802-25		'ACT7802-40		'ACT7802-60		UNIT
		MIN	MAX	MIN	MAX	MIN	MAX	
f_{clock}	Clock frequency	40		25		16.7		MHz
t_w	Pulse duration	LDCK high or low	10	14	20			ns
		UNCK high or low	10	14	20			
		$\overline{\text{DAF}}$ high	10	10	10			
		$\overline{\text{RESET}}$ low	20	25	25			
t_{su}	Setup time	D0–D7 before LDCK \uparrow	4	5	5			ns
		$\overline{\text{RESET}}$ inactive (high) before LDCK \uparrow	5	5	5			
		Define AF/AE: D0–D8 before $\overline{\text{DAF}}\downarrow$	5	5	5			
		Define AF/AE: $\overline{\text{DAF}}\downarrow$ before $\overline{\text{RESET}}\uparrow$	7	7	7			
		Define AF/AE (default): $\overline{\text{DAF}}$ high before $\overline{\text{RESET}}\uparrow$	5	5	5			
t_h	Hold time	D0–D7 after LDCK \uparrow	1	2	2			ns
		Define AF/AE: D0–D8 after $\overline{\text{DAF}}\downarrow$	0	0	0			
		Define AF/AE: $\overline{\text{DAF}}$ low after $\overline{\text{RESET}}\uparrow$	0	0	0			
		Define AF/AE (default): $\overline{\text{DAF}}$ high after $\overline{\text{RESET}}\uparrow$	0	0	0			

switching characteristics over recommended ranges of supply voltage and operating free-air temperature, $C_L = 50$ pF (see Figures 1 and 2)

PARAMETER	FROM (INPUT)	TO (OUTPUT)	'ACT7802-25			'ACT7802-40		'ACT7802-60		UNIT
			MIN	TYP \dagger	MAX	MIN	MAX	MIN	MAX	
f_{max}	LDCK or UNCK		40			25		16.7		MHz
t_{pd}	LDCK \uparrow	Any Q	8	20	30	8	35	8	45	ns
	UNCK \uparrow		12		30	12	35	12	45	
t_{pd}^\ddagger	UNCK \uparrow	Any Q	21							ns
t_{PLH}	LDCK \uparrow	$\overline{\text{EMPTY}}$	4		18	4	20	4	22	ns
t_{PHL}	UNCK \uparrow	$\overline{\text{EMPTY}}$	2		18	2	20	2	22	ns
	$\overline{\text{RESET}}\downarrow$		2		18	2	20	2	22	
	LDCK \uparrow	$\overline{\text{FULL}}$	4		18	4	20	4	22	
t_{PLH}	UNCK \uparrow	$\overline{\text{FULL}}$	4		17	4	19	4	21	ns
	$\overline{\text{RESET}}\downarrow$		2		17	2	19	2	21	
t_{pd}	LDCK \uparrow	AF/AE	2		20	2	22	2	24	ns
	UNCK \uparrow		2		20	2	22	2	24	
t_{PLH}	$\overline{\text{RESET}}\downarrow$	AF/AE	2		17	2	19	2	21	ns
	LDCK \uparrow	HF	2		18	2	20	2	22	
t_{PHL}	UNCK \uparrow	HF	2		18	2	20	2	22	ns
	$\overline{\text{RESET}}\downarrow$		2		17	2	19	2	21	
t_{en}	OE	Any Q	2		12	2	14	2	16	ns
t_{dis}	OE	Any Q	2		14	2	16	2	18	ns

 \dagger All typical values are at $V_{\text{CC}} = 5$ V, $T_A = 25^\circ\text{C}$. \ddagger This parameter is measured with $C_L = 30$ pF (see Figure 3).operating characteristics, $V_{\text{CC}} = 5$ V, $T_A = 25^\circ\text{C}$

PARAMETER	TEST CONDITIONS	TYP	UNIT
C_{pd}	Power dissipation capacitance per channel	$C_L = 50$ pF, $f = 5$ MHz	65 pF



PARAMETER MEASUREMENT INFORMATION

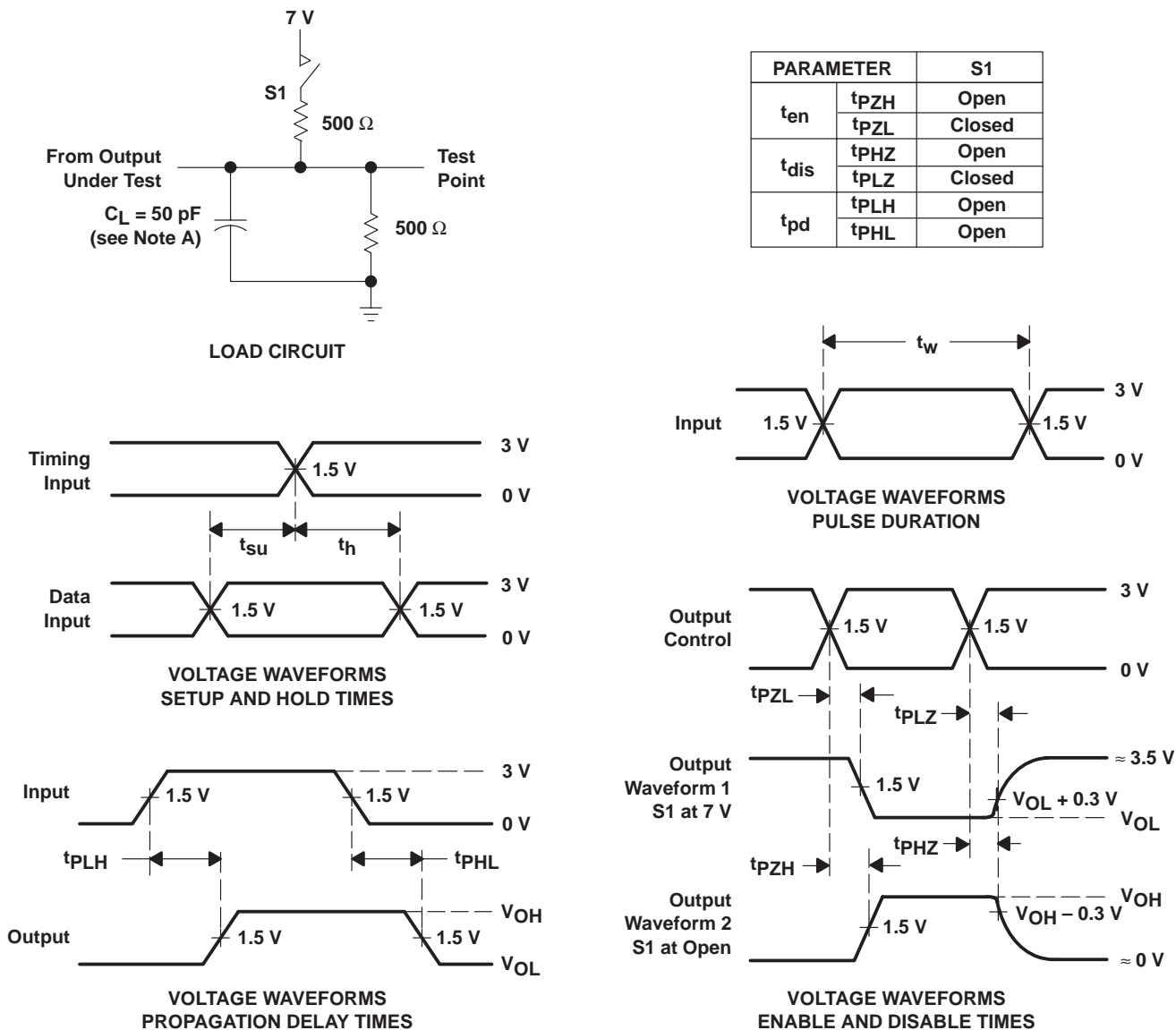

NOTE A: CL includes probe and jig capacitance.

Figure 2. Load Circuit and Voltage Waveforms

SN74ACT7802

1024 × 18 STROBED FIRST-IN, FIRST-OUT MEMORY

SCAS187D – AUGUST 1990 – REVISED APRIL 1998

TYPICAL CHARACTERISTICS

**PROPAGATION DELAY TIME
vs
LOAD CAPACITANCE**

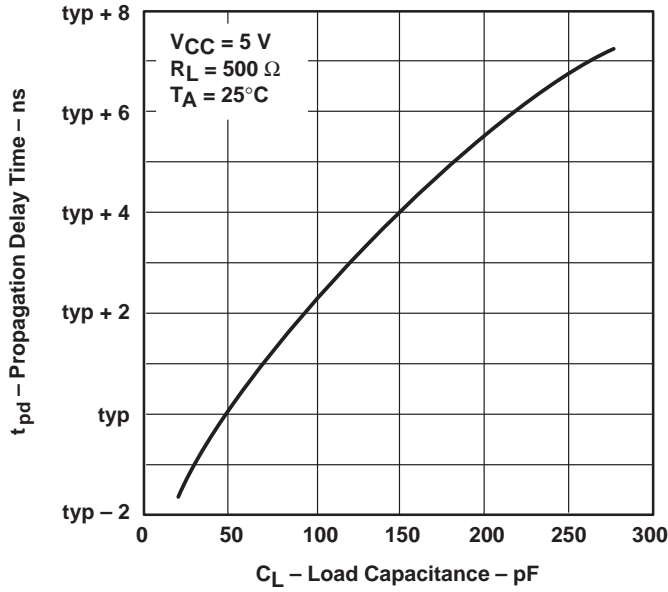

Figure 3

**POWER DISSIPATION CAPACITANCE
vs
SUPPLY VOLTAGE**

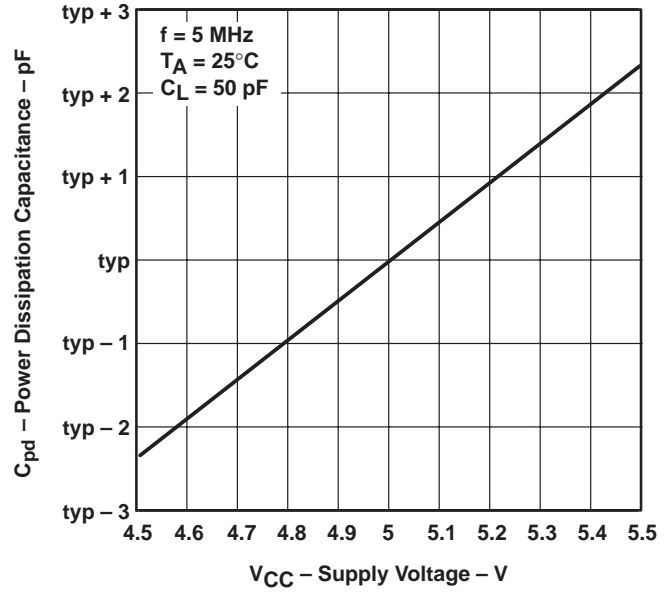

Figure 4

APPLICATION INFORMATION

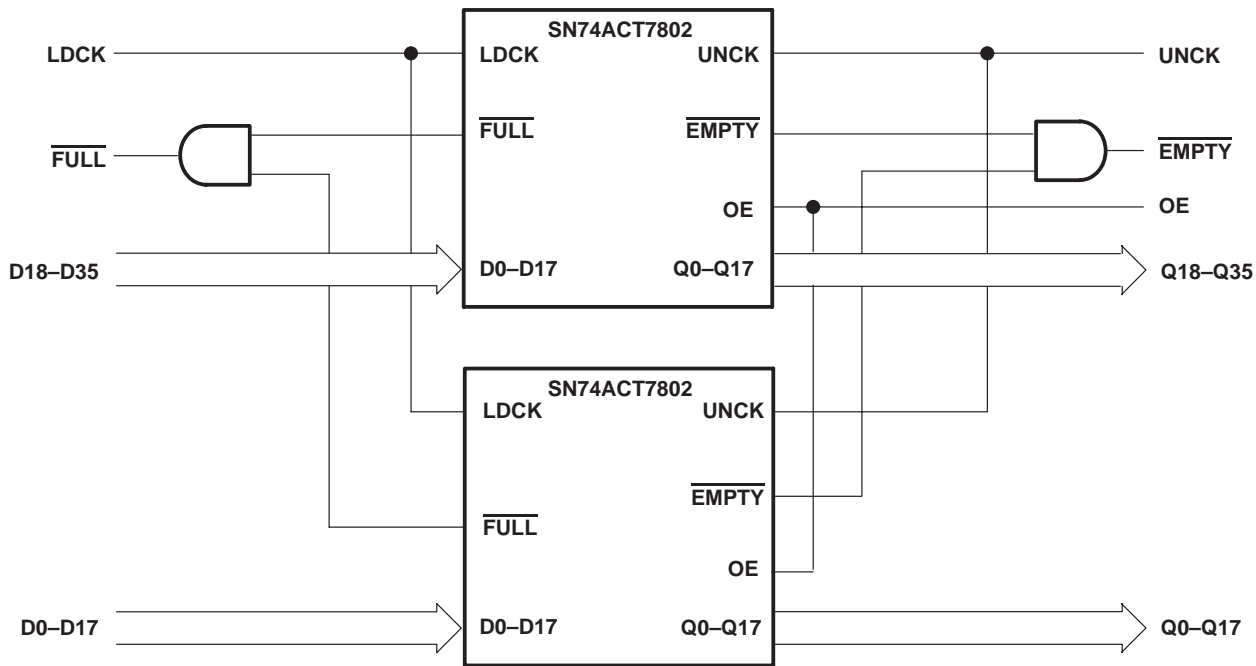

Figure 5. Word-Width Expansion: 1024 × 36 Bit

IMPORTANT NOTICE

Texas Instruments and its subsidiaries (TI) reserve the right to make changes to their products or to discontinue any product or service without notice, and advise customers to obtain the latest version of relevant information to verify, before placing orders, that information being relied on is current and complete. All products are sold subject to the terms and conditions of sale supplied at the time of order acknowledgement, including those pertaining to warranty, patent infringement, and limitation of liability.

TI warrants performance of its semiconductor products to the specifications applicable at the time of sale in accordance with TI's standard warranty. Testing and other quality control techniques are utilized to the extent TI deems necessary to support this warranty. Specific testing of all parameters of each device is not necessarily performed, except those mandated by government requirements.

CERTAIN APPLICATIONS USING SEMICONDUCTOR PRODUCTS MAY INVOLVE POTENTIAL RISKS OF DEATH, PERSONAL INJURY, OR SEVERE PROPERTY OR ENVIRONMENTAL DAMAGE ("CRITICAL APPLICATIONS"). TI SEMICONDUCTOR PRODUCTS ARE NOT DESIGNED, AUTHORIZED, OR WARRANTED TO BE SUITABLE FOR USE IN LIFE-SUPPORT DEVICES OR SYSTEMS OR OTHER CRITICAL APPLICATIONS. INCLUSION OF TI PRODUCTS IN SUCH APPLICATIONS IS UNDERSTOOD TO BE FULLY AT THE CUSTOMER'S RISK.

In order to minimize risks associated with the customer's applications, adequate design and operating safeguards must be provided by the customer to minimize inherent or procedural hazards.

TI assumes no liability for applications assistance or customer product design. TI does not warrant or represent that any license, either express or implied, is granted under any patent right, copyright, mask work right, or other intellectual property right of TI covering or relating to any combination, machine, or process in which such semiconductor products or services might be or are used. TI's publication of information regarding any third party's products or services does not constitute TI's approval, warranty or endorsement thereof.

OUR CERTIFICATE

DiGi provide top-quality products and perfect service for customer worldwide through standardization, technological innovation and continuous improvement. DiGi through third-party certification, we stricly control the quality of products and services. Welcome your RFQ to

Email: Info@DiGi-Electronics.com



Tel: +00 852-30501935

RFQ Email: Info@DiGi-Electronics.com

DiGi is a global authorized distributor of electronic components.