

FD7-16 Datasheet



<https://www.DiGi-Electronics.com>

DiGi Electronics Part Number	FD7-16-DG
Manufacturer	Triad Magnetics
Manufacturer Product Number	FD7-16
Description	PWR XFMR LAMINATED 56VA CHAS MT
Detailed Description	Transformers

This model FD7-16 is available at DiGi Electronics.

DiGi Electronics offers a global database of semiconductor and electronic component datasheets.

We welcome your inquiries regarding pricing, lead time, or other product-related questions.

 [Request a Quote](#)

 [Datasheet Search](#)



Tel: +00 852-30501935

RFQ Email: Info@DiGi-Electronics.com

DiGi is a global authorized distributor of electronic components.

Purchase and inquiry

Manufacturer Product Number:

FD7-16

Series:

Quick Pack

Type:

Laminated Core

Voltage - Secondary (Full Load):

16V

Primary Winding(s):

Dual

Center Tap:

Yes

Mounting Type:

Chassis Mount

Size / Dimension:

93.65mm L x 46.02mm W

Voltage - Isolation:

2500VAC

Manufacturer:

Triad Magnetics

Product Status:

Active

Voltage - Primary:

115V, 230V

Current - Output (Max):

3.5A

Secondary Winding(s):

Single

Power - Max:

56VA

Termination Style:

Solder, Quick Connect - 0.187" (4.7mm)

Height - Seated (Max):

57.15mm

Weight:

1.7 lbs (771.1 g)

Environmental & Export classification

RoHS Status:

ROHS3 Compliant

REACH Status:

REACH Unaffected

HTSUS:

8504.31.4065

Moisture Sensitivity Level (MSL):

Not Applicable

ECCN:

EAR99



Power Transformer Chassis Mount: Quick Pack

FD7-16

Description:

The FD7-16 Quick Pack small power transformer offers a significant reduction in size and weight over a standard transformer. This transformer can be used for a wide variety of applications. It is bobbin wound for reduced size and small operating space.

Electrical Specifications (@25C):

Maximum Power: 56.0VA

Input Voltage:

Series: 230VAC@50/60Hz

Parallel: 115VAC@50/60Hz

Output Voltage: 16.0VCT@3.5A¹

Recommended Fuse: UL listed 250VAC, 4.0A, Slo-Blo

Hipot: 2500VAC primary to secondary; 1500VAC windings to core.

Construction:

Split bobbin non concentric winding eliminates costly electrostatic shielding. Termination is suitable for quick connects or soldering. Built with UL Class B Insulation System.

Safety:

UL: File E53148, UL 5085-1 and 2 (formerly UL 506), General Purpose.

UL: File E65390, UL5085-1 and 3, Class 2 not wet, Class 3 wet



Dimensions:

A	B	C	D	E	F	G
2.250	3.125	3.687	1.812	2.687	.187 Dia	1.062

Notes: 1. Units: inches.

2. Terminal size: .187" X 0.021".

3. Weight: 1.70 lbs

Schematic:

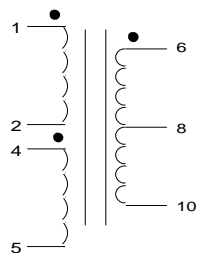

Output: 6 & 10

Input (115V): Input 1 & 2

Connect 1&4, 2&5

Input (230V): Input 1 & 5

Connect 2&4

RoHS Compliance: As of manufacturing date February 2016, all standard products meet the requirements of 2015/863/EU, known as the RoHS 3 initiative.

* Upon printing, this document is considered "uncontrolled". Please contact Triad Magnetics' website for the most current version.

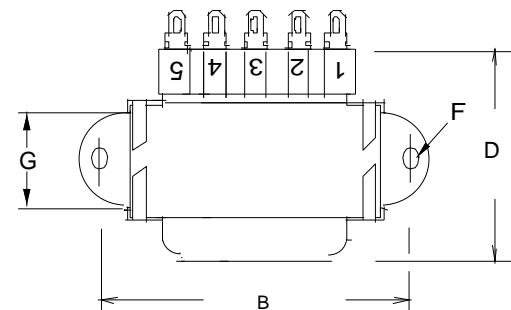
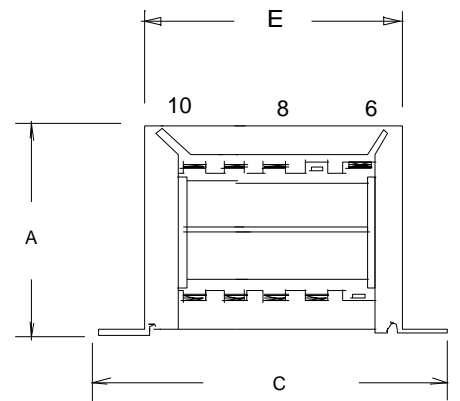
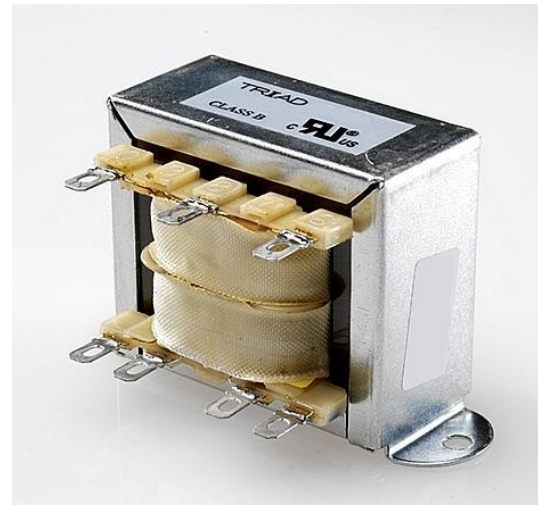

¹ Fuse must be used on **secondary** as conditions of acceptability for UL Class 2/3 operation

OUR CERTIFICATE

DiGi provide top-quality products and perfect service for customer worldwide through standardization, technological innovation and continuous improvement. DiGi through third-party certification, we stricly control the quality of products and services. Welcome your RFQ to

Email: Info@DiGi-Electronics.com



Tel: +00 852-30501935

RFQ Email: Info@DiGi-Electronics.com

DiGi is a global authorized distributor of electronic components.