

# VS-VSKT136/14PBF Datasheet

[www.digi-electronics.com](http://www.digi-electronics.com)



<https://www.DiGi-Electronics.com>

|                              |   |
|------------------------------|---|
| DiGi Electronics Part Number | VS-VSKT136/14PBF-DG   |
| Manufacturer                 | <a href="#">Vishay General Semiconductor - Diodes Division</a>                |
| Manufacturer Product Number  | VS-VSKT136/14PBF  |
| Description                  | MOD PH CTRL 1400V 135A INT-A-PAK  |
| Detailed Description         | SCR Module 1.4 kV 300 A Series Connection - All SC Rs Chassis Mount INT-A-Pak |

This model VS-VSKT136/14PBF is available at DiGi Electronics.

DiGi Electronics offers a global database of semiconductor and electronic component datasheets.

We welcome your inquiries regarding pricing, lead time, or other product-related questions.

 [Request a Quote](#)

 [Datasheet Search](#)



Tel: +00 852-30501935

RFQ Email: [Info@DiGi-Electronics.com](mailto:Info@DiGi-Electronics.com)

DiGi is a global authorized distributor of electronic components.

## Purchase and inquiry

Manufacturer Product Number:

VS-VSKT136/14PBF

Series:

-

Structure:

Series Connection - All SCRs

Voltage - Off State:

1.4 kV

Current - On State (It (RMS)) (Max):

300 A

Current - Gate Trigger (Igt) (Max):

150 mA

Current - Hold (Ih) (Max):

200 mA

Mounting Type:

Chassis Mount

Base Product Number:

VSKT136

Manufacturer:

Vishay General Semiconductor - Diodes Division

Product Status:

Active

Number of SCRs, Diodes:

2 SCRs

Current - On State (It (AV)) (Max):

135 A

Voltage - Gate Trigger (Vgt) (Max):

2.5 V

Current - Non Rep. Surge 50, 60Hz (I<sub>tsm</sub>):

3200A, 3360A

Operating Temperature:

-40°C ~ 125°C (Tj)

Package / Case:

INT-A-Pak

## Environmental & Export classification

RoHS Status:

ROHS3 Compliant

REACH Status:

REACH Unaffected

HTSUS:

8541.30.0080

Moisture Sensitivity Level (MSL):

1 (Unlimited)

ECCN:

EAR99



# VS-VSK.136..PbF, VS-VSK.142..PbF, VS-VSK.162..PbF Series

[www.vishay.com](http://www.vishay.com)

Vishay Semiconductors

## Thyristor/Diode and Thyristor/Thyristor, 135 A to 160 A (INT-A-PAK Power Modules)



INT-A-PAK

| PRIMARY CHARACTERISTICS |                               |
|-------------------------|-------------------------------|
| $I_{T(AV)}$             | 135 A to 160 A                |
| Type                    | Modules - thyristor, standard |
| Package                 | INT-A-PAK                     |

### FEATURES

- High voltage
- Electrically isolated by DBC ceramic ( $Al_2O_3$ )
- 3500  $V_{RMS}$  isolating voltage
- Industrial standard package
- High surge capability
- Glass passivated chips
- Modules uses high voltage power thyristor/diodes in three basic configurations
- Simple mounting
- UL approved file E78996 
- Designed and qualified for multiple level
- Material categorization: for definitions of compliance please see [www.vishay.com/doc?99912](http://www.vishay.com/doc?99912)



RoHS  
COMPLIANT

### APPLICATIONS

- DC motor control and drives
- Battery charges
- Welders
- Power converters
- Lighting control
- Heat and temperature control

| MAJOR RATINGS AND CHARACTERISTICS |                 |             |             |             |                    |
|-----------------------------------|-----------------|-------------|-------------|-------------|--------------------|
| SYMBOL                            | CHARACTERISTICS | VSK.136..   | VSK.142..   | VSK.162..   | UNITS              |
| $I_{T(AV)}$                       | 85 °C           | 135         | 140         | 160         | A                  |
| $I_{T(RMS)}$                      |                 | 300         | 310         | 355         | A                  |
| $I_{TSM}$                         | 50 Hz           | 3200        | 4500        | 4870        |                    |
|                                   | 60 Hz           | 3360        | 4712        | 5100        |                    |
| $I^2t$                            | 50 Hz           | 51.5        | 102         | 119         | kA <sup>2</sup> s  |
|                                   | 60 Hz           | 47          | 92.5        | 108         |                    |
| $I^2\sqrt{t}$                     |                 | 515.5       | 1013        | 1190        | kA <sup>2</sup> √s |
| $V_{RRM}$                         | Range           | 400 to 1600 | 400 to 1600 | 400 to 1600 | V                  |
| $T_J$                             | Range           | -40 to +125 |             |             | °C                 |

### ELECTRICAL SPECIFICATIONS

| VOLTAGE RATINGS                        |              |  |  |                                   |
|--|--------------|--|--|-----------------------------------|
| TYPE NUMBER                            | VOLTAGE CODE | $V_{RRM}/V_{DRM}$ , MAXIMUM REPETITIVE PEAK REVERSE VOLTAGE<br>V | $V_{RSM}/V_{DSM}$ , MAXIMUM NON-REPETITIVE PEAK REVERSE VOLTAGE<br>V | $I_{RRM}/I_{DRM}$ AT 125 °C<br>mA |
| VS-VSK.136<br>VS-VSK.142<br>VS-VSK.162 | 04           | 400  | 500  | 50                                |
|  | 08           | 800  | 900  |                                   |
|  | 12           | 1200   | 1300   |                                   |
|  | 14           | 1400   | 1500   |                                   |
|  | 16           | 1600   | 1700   |                                   |



# VS-VSK.136..PbF, VS-VSK.142..PbF, VS-VSK.162..PbF Series

[www.vishay.com](http://www.vishay.com)

Vishay Semiconductors

| ON-STATE CONDUCTION  |               |  |                            |         |         |         |                    |
|--|---------------|--|----------------------------|---------|---------|---------|--------------------|
| PARAMETER  | SYMBOL        | TEST CONDITIONS  |                            | VSK.136 | VSK.142 | VSK.162 | UNITS              |
| Maximum average on-state current at case temperature           | $I_{T(AV)}$   | 180° conduction, half sine wave  |                            | 135     | 140     | 160     | A                  |
|  |               |  |                            | 85      | 85      | 85      | °C                 |
| Maximum RMS on-state current                                   | $I_{T(RMS)}$  | As AC switch   |                            | 300     | 310     | 355     | A                  |
| Maximum peak, one-cycle on-state, non-repetitive surge current | $I_{TSM}$     | t = 10 ms  | No voltage reappplied      | 3200    | 4500    | 4870    |                    |
|  |               | t = 8.3 ms   | No voltage reappplied      | 3360    | 4712    | 5100    |                    |
|  |               | t = 10 ms  | 100 % $V_{RRM}$ reappplied | 2700    | 3785    | 4100    |                    |
|  |               | t = 8.3 ms   | 100 % $V_{RRM}$ reappplied | 2800    | 3963    | 4300    |                    |
| Maximum $I^2t$ for fusing                                      | $I^2t$        | t = 10 ms  | No voltage reappplied      | 51.5    | 102     | 119     | kA <sup>2</sup> s  |
|  |               | t = 8.3 ms   | No voltage reappplied      | 47      | 92.5    | 108     |                    |
|  |               | t = 10 ms  | 100 % $V_{RRM}$ reappplied | 36.5    | 71.6    | 84      |                    |
|  |               | t = 8.3 ms   | 100 % $V_{RRM}$ reappplied | 33.3    | 65.4    | 76.7    |                    |
| Maximum $I^2\sqrt{t}$ for fusing                               | $I^2\sqrt{t}$ | t = 0.1 ms to 10 ms, no voltage reappplied   |                            | 515.5   | 1013    | 1190    | kA <sup>2</sup> √s |
| Low level value of threshold voltage                           | $V_{T(TO)1}$  | (16.7 % $\times \pi \times I_{T(AV)} < I < \pi \times I_{T(AV)}$ ), $T_J$ maximum          |                            | 0.86    | 0.83    | 0.8     | V                  |
| High level value of threshold voltage                          | $V_{T(TO)2}$  | (I > $\pi \times I_{T(AV)}$ ), $T_J$ maximum   |                            | 1.05    | 1       | 0.98    |                    |
| Low level value on-state slope resistance                      | $r_{t1}$      | (16.7 % $\times \pi \times I_{T(AV)} < I < \pi \times I_{T(AV)}$ ), $T_J$ maximum          |                            | 2.02    | 1.78    | 1.67    | mΩ                 |
| High level value on-state slope resistance                     | $r_{t2}$      | (I > $\pi \times I_{T(AV)}$ ), $T_J$ maximum   |                            | 1.65    | 1.43    | 1.38    |                    |
| Maximum on-state voltage drop                                  | $V_{TM}$      | $I_{TM} = \pi \times I_{T(AV)}$ , $T_J = 25^\circ\text{C}$ , 180° conduction               |                            | 1.57    | 1.55    | 1.54    | V                  |
| Maximum forward voltage drop                                   | $V_{FM}$      | $I_{TM} = \pi \times I_{T(AV)}$ , $T_J = 25^\circ\text{C}$ , 180° conduction               |                            | 1.57    | 1.55    | 1.54    | V                  |
| Maximum holding current  | $I_H$         | Anode supply = 6 V initial $I_T = 30$ A, $T_J = 25^\circ\text{C}$                          |                            | 200     |         | mA      |                    |
| Maximum latching current                                       | $I_L$         | Anode supply = 6 V resistive load = 1 Ω Gate pulse: 10 V, 100 μs, $T_J = 25^\circ\text{C}$ |                            | 400     |         |         |                    |

| SWITCHING             |          |  |  |           |       |
|-----------------------|----------|--|--|-----------|-------|
| PARAMETER             | SYMBOL   | TEST CONDITIONS  |  | VALUES    | UNITS |
| Typical delay time    | $t_{gd}$ | $T_J = 25^\circ\text{C}$   | Gate current = 1 A, $di_g/dt = 1$ A/μs<br>$V_d = 0.67$ % $V_{DRM}$ | 1         | μs    |
| Typical rise time     | $t_{gr}$ |  |  | 2         |       |
| Typical turn-off time | $t_q$    | $I_{TM} = 300$ A, - $di/dt = 15$ A/μs; $T_J = T_J$ maximum<br>$V_R = 50$ V; $dV/dt = 20$ V/μs; gate 0 V, 100 Ω |  | 50 to 200 |       |

| BLOCKING   |                          |  |  |        |       |
|--|--------------------------|--|--|--------|-------|
| PARAMETER  | SYMBOL                   | TEST CONDITIONS  |  | VALUES | UNITS |
| Maximum peak reverse and off-state leakage current | $I_{RRM}$ ,<br>$I_{DRM}$ | $T_J = 125^\circ\text{C}$                                |  | 50     | mA    |
| RMS insulation voltage                             | $V_{INS}$                | 50 Hz, circuit to base, all terminals shorted, t = 1 s   |  | 3500   | V     |
| Critical rate of rise of off-state voltage         | $dV/dt$                  | $T_J = T_J$ maximum, exponential to 67 % rated $V_{DRM}$ |  | 1000   | V/μs  |

**VS-VSK.136..PbF, VS-VSK.142..PbF, VS-VSK.162..PbF Series**
[www.vishay.com](http://www.vishay.com)

Vishay Semiconductors

| TRIGGERING                                  |             |   |   |        |            |
|---|-------------|---|---|--------|------------|
| PARAMETER                                   | SYMBOL      | TEST CONDITIONS   |   | VALUES | UNITS      |
| Maximum peak gate power                     | $P_{GM}$    | $t_p \leq 5$ ms, $T_J = T_J$ maximum                          |   | 12     | W          |
| Maximum average gate power                  | $P_{G(AV)}$ | $f = 50$ Hz, $T_J = T_J$ maximum                              |   | 3      |            |
| Maximum peak gate current                   | $I_{GM}$    | $t_p \leq 5$ ms, $T_J = T_J$ maximum                          |   | 3      | A          |
| Maximum peak negative gate voltage          | $-V_{GT}$   |   |   | 10     | V          |
| Maximum required DC gate voltage to trigger | $V_{GT}$    | $T_J = -40$ °C  | Anode supply = 6 V,<br>resistive load; $R_a = 1$ $\Omega$ | 4      |            |
|   |             | $T_J = 25$ °C   |   | 2.5    |            |
|   |             | $T_J = T_J$ maximum   |   | 1.7    |            |
| Maximum required DC gate current to trigger | $I_{GT}$    | $T_J = -40$ °C  |   | 270    | mA         |
|   |             | $T_J = 25$ °C   |   | 150    |            |
|   |             | $T_J = T_J$ maximum   |   | 80     |            |
| Maximum gate voltage that will not trigger  | $V_{GD}$    | $T_J = T_J$ maximum, rated $V_{DRM}$ applied                  |   | 0.3    | V          |
| Maximum gate current that will not trigger  | $I_{GD}$    |   |   | 10     | mA         |
| Maximum rate of rise of turned-on current   | $di/dt$     | $T_J = T_J$ maximum, $I_{TM} = 400$ A rated $V_{DRM}$ applied |   | 300    | A/ $\mu$ s |

| THERMAL AND MECHANICAL SPECIFICATIONS                     |                                  |  |             |         |         |       |
|---|----------------------------------|--|-------------|---------|---------|-------|
| PARAMETER   | SYMBOL                           | TEST CONDITIONS  | VSK.136     | VSK.142 | VSK.162 | UNITS |
| Maximum junction operating temperature range              | $T_J$                            |  | -40 to +125 |         |         | °C    |
| Maximum storage temperature range                         | $T_{Stg}$                        |  | -40 to +150 |         |         |       |
| Maximum thermal resistance, junction to case per junction | $R_{thJC}$                       | DC operation   | 0.18        | 0.18    | 0.16    | K/W   |
| Maximum thermal resistance, case to heatsink per module   | $R_{thCS}$                       | Mounting surface, smooth, flat and greased   | 0.05        |         |         |       |
| Mounting torque $\pm 10$ %                                | IAP to heatsink<br>busbar to IAP | A mounting compound is recommended and the torque should be rechecked after a period of 3 hours to allow for the spread of the compound. Lubricated threads. | 4 to 6      |         |         | Nm    |
| Approximate weight  |                                  |  | 200         |         |         | g     |
| Case style  |                                  |  | 7.1         |         |         | oz.   |
|   |                                  |  | INT-A-PAK   |         |         |       |

| $\Delta R$ CONDUCTION PER JUNCTION |  |        |        |        |        |   |        |        |        |        |       |
|------------------------------------|--|--------|--------|--------|--------|---|--------|--------|--------|--------|-------|
| DEVICES                            | SINUSOIDAL CONDUCTION AT $T_J$ MAXIMUM |        |        |        |        | RECTANGULAR CONDUCTION AT $T_J$ MAXIMUM |        |        |        |        | UNITS |
|                                    | 180°                                   | 120°   | 90°    | 60°    | 30°    | 180°                                    | 120°   | 90°    | 60°    | 30°    |       |
| VSK.136                            | 0.007                                  | 0.01   | 0.013  | 0.0155 | 0.017  | 0.009                                   | 0.012  | 0.014  | 0.015  | 0.017  | K/W   |
| VSK.142                            | 0.0019                                 | 0.0019 | 0.0020 | 0.0020 | 0.0021 | 0.0018                                  | 0.0022 | 0.0023 | 0.0023 | 0.0020 |       |
| VSK.162                            | 0.0030                                 | 0.0031 | 0.0032 | 0.0033 | 0.0034 | 0.0029                                  | 0.0036 | 0.0039 | 0.0041 | 0.0040 |       |

**Note**

- Table shows the increment of thermal resistance  $R_{thJC}$  when devices operate at different conduction angles than DC



# VS-VSK.136..PbF, VS-VSK.142..PbF, VS-VSK.162..PbF Series

[www.vishay.com](http://www.vishay.com)

Vishay Semiconductors

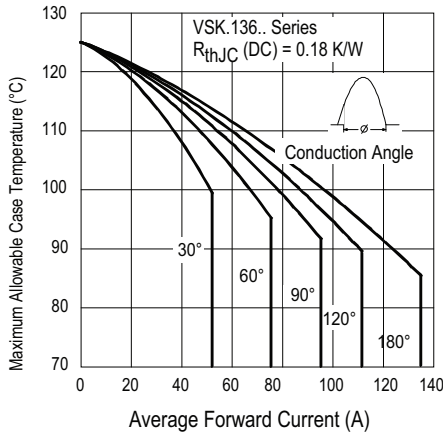

Fig. 1 - Current Ratings Characteristics

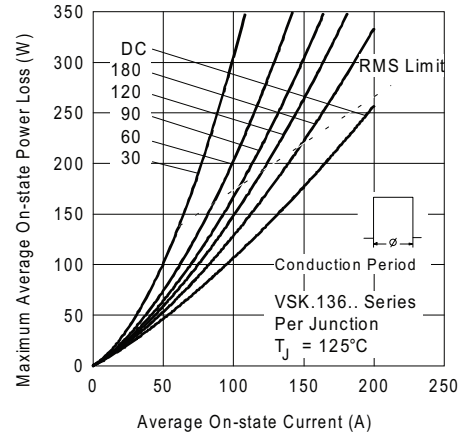

Fig. 4 - On-State Power Loss Characteristics

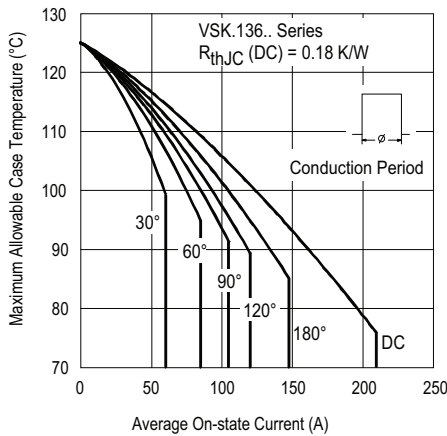

Fig. 2 - Current Ratings Characteristics

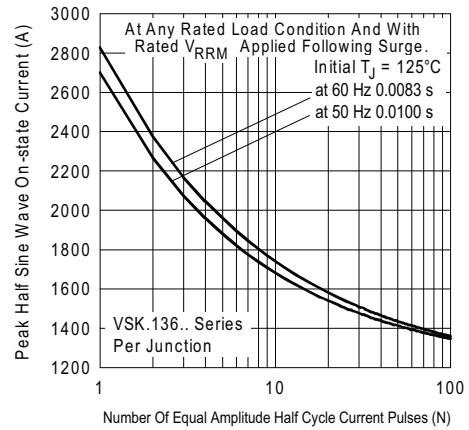

Fig. 5 - Maximum Non-Repetitive Surge Current

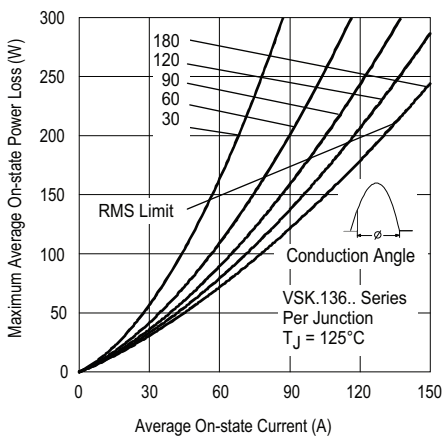

Fig. 3 - On-State Power Loss Characteristics

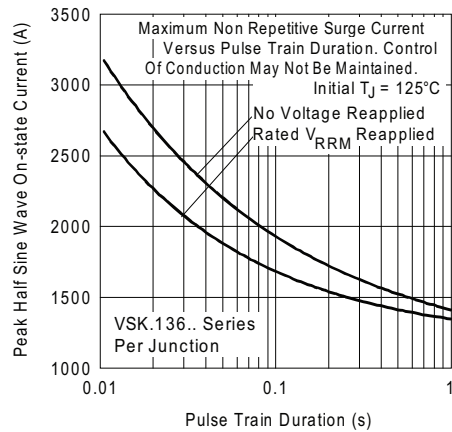

Fig. 6 - Maximum Non-Repetitive Surge Current



# VS-VSK.136..PbF, VS-VSK.142..PbF, VS-VSK.162..PbF Series

[www.vishay.com](http://www.vishay.com)

Vishay Semiconductors

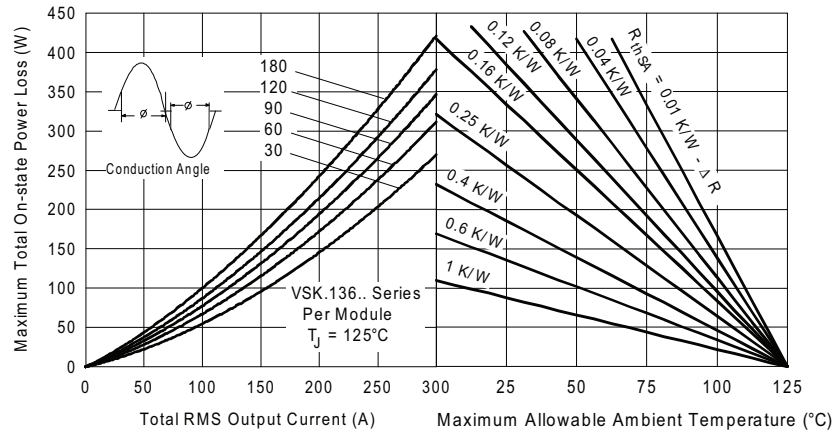

Fig. 7 - On-State Power Loss Characteristics

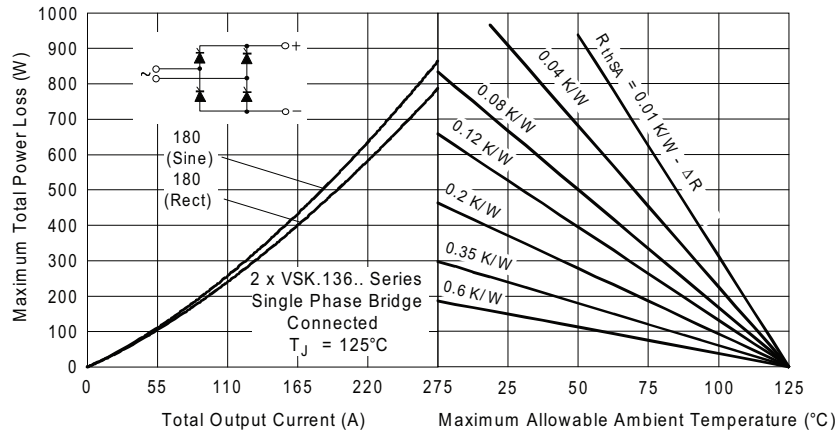

Fig. 8 - On-State Power Loss Characteristics

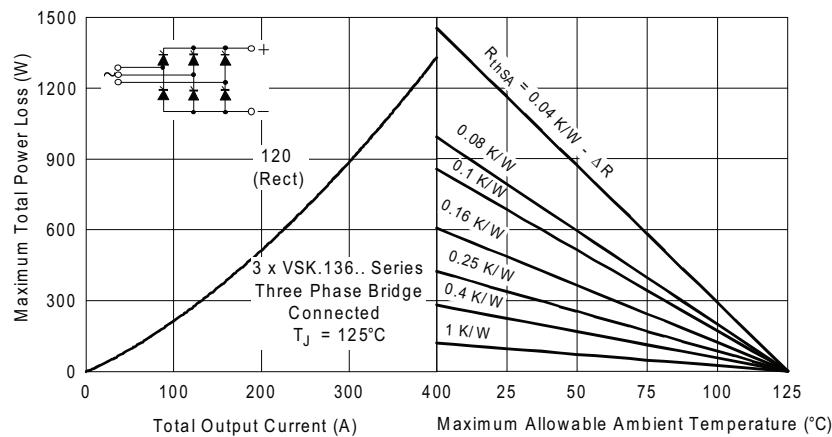

Fig. 9 - On-State Power Loss Characteristics



# VS-VSK.136..PbF, VS-VSK.142..PbF, VS-VSK.162..PbF Series

[www.vishay.com](http://www.vishay.com)

Vishay Semiconductors

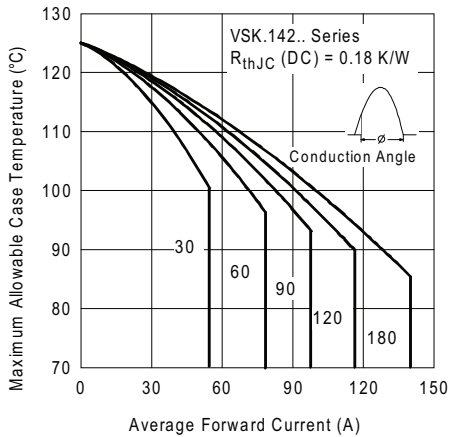

Fig. 10 - Current Ratings Characteristics

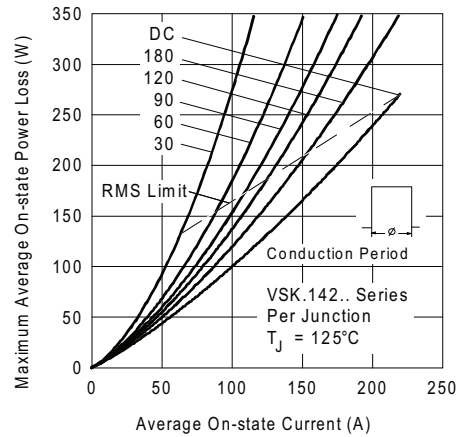

Fig. 13 - On-State Power Loss Characteristics

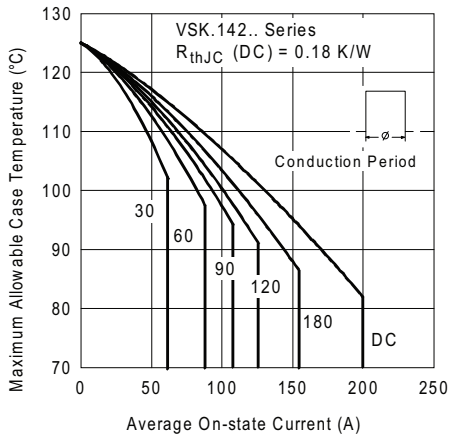

Fig. 11 - Current Ratings Characteristics

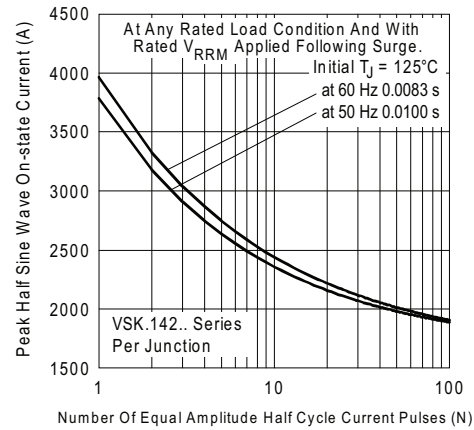

Fig. 14 - Maximum Non-Repetitive Surge Current

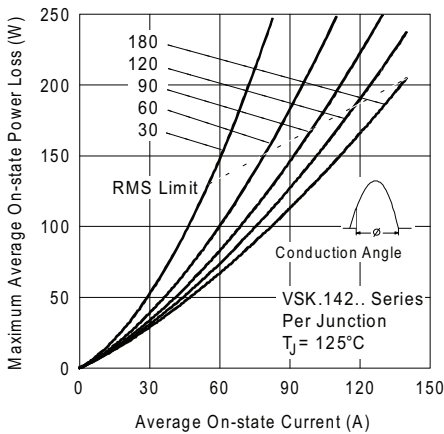

Fig. 12 - On-State Power Loss Characteristics

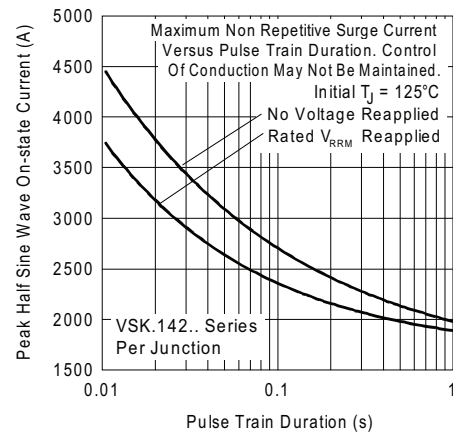

Fig. 15 - Maximum Non-Repetitive Surge Current



# VS-VSK.136..PbF, VS-VSK.142..PbF, VS-VSK.162..PbF Series

[www.vishay.com](http://www.vishay.com)

Vishay Semiconductors

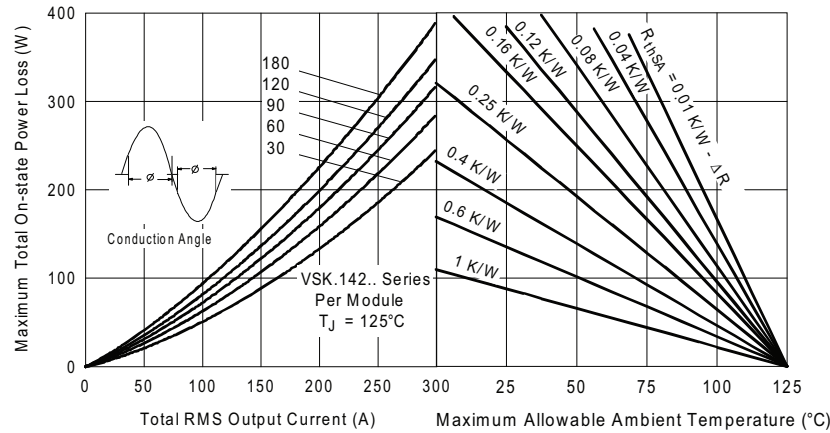

Fig. 16 - On-State Power Loss Characteristics

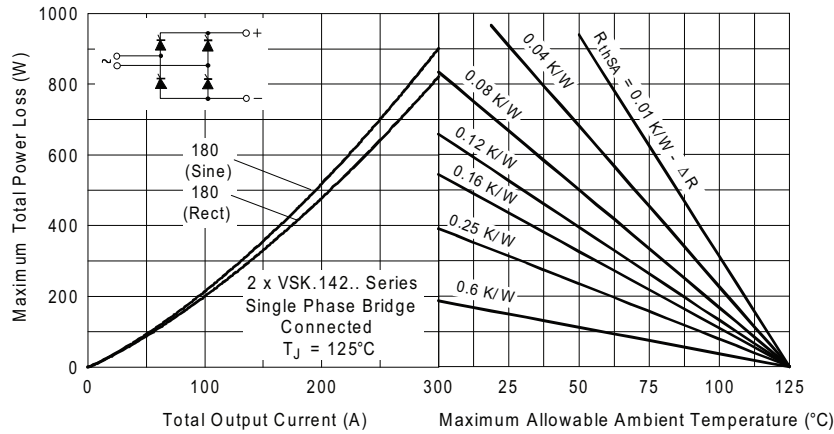

Fig. 17 - On-State Power Loss Characteristics

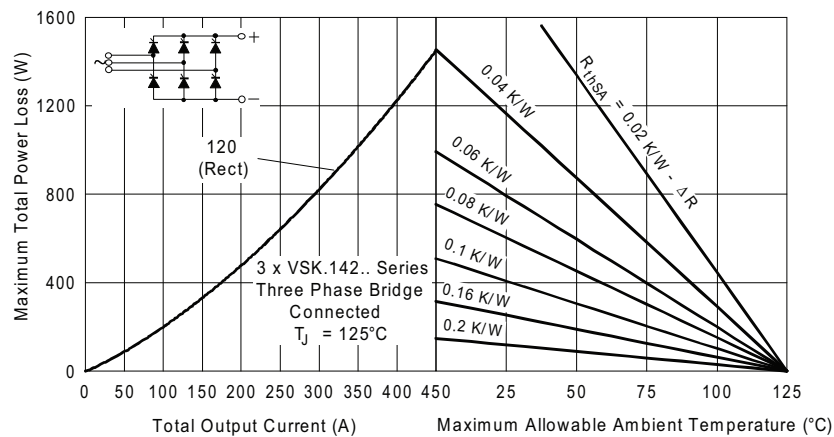

Fig. 18 - On-State Power Loss Characteristics



# VS-VSK.136..PbF, VS-VSK.142..PbF, VS-VSK.162..PbF Series

[www.vishay.com](http://www.vishay.com)

Vishay Semiconductors

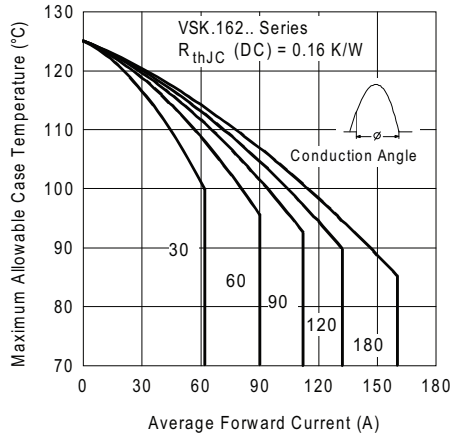

Fig. 19 - Current Ratings Characteristics

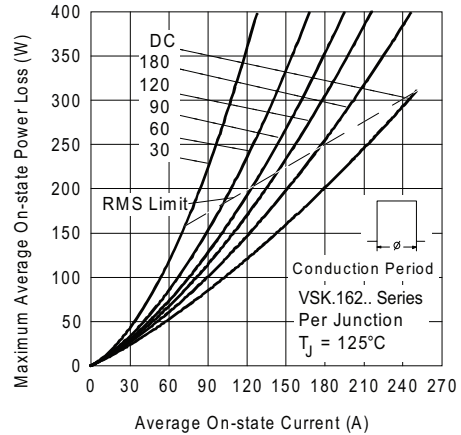

Fig. 22 - On-State Power Loss Characteristics

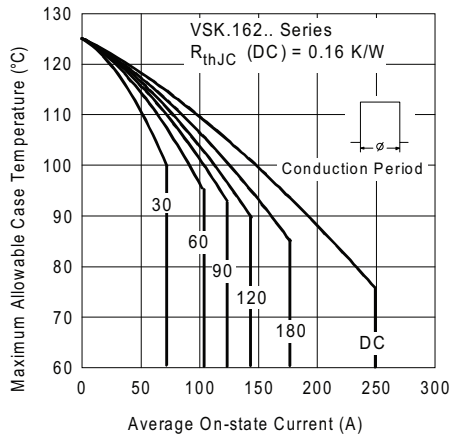

Fig. 20 - Current Ratings Characteristics

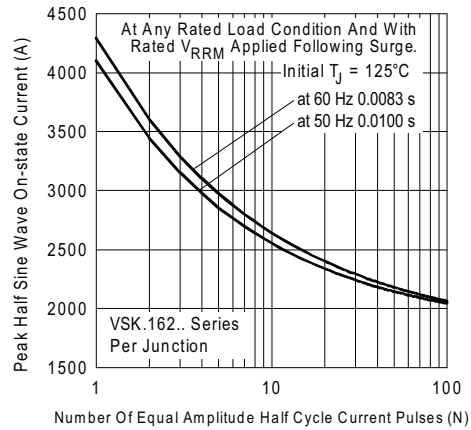

Fig. 23 - Maximum Non-Repetitive Surge Current

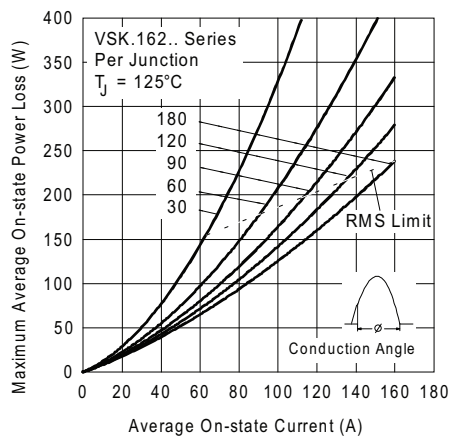

Fig. 21 - On-State Power Loss Characteristics

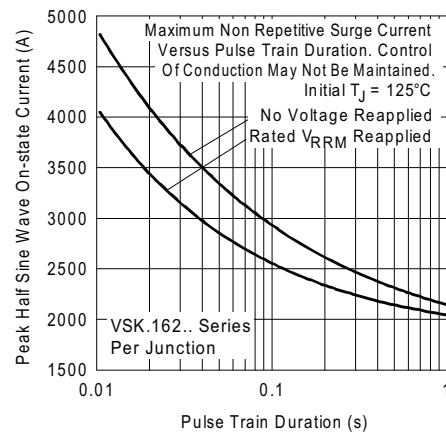

Fig. 24 - Maximum Non-Repetitive Surge Current



# VS-VSK.136..PbF, VS-VSK.142..PbF, VS-VSK.162..PbF Series

[www.vishay.com](http://www.vishay.com)

Vishay Semiconductors

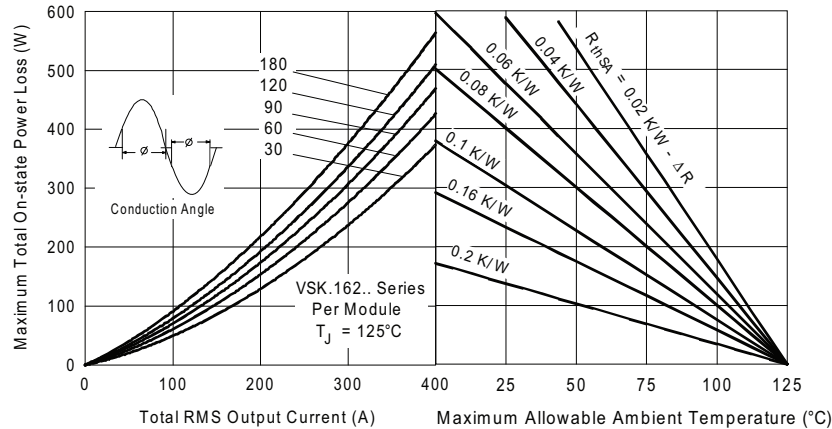

Fig. 25 - On-State Power Loss Characteristics

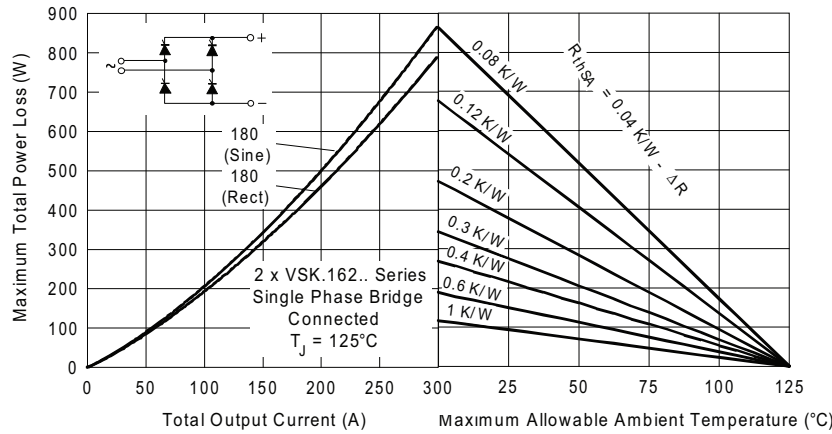

Fig. 26 - On-State Power Loss Characteristics

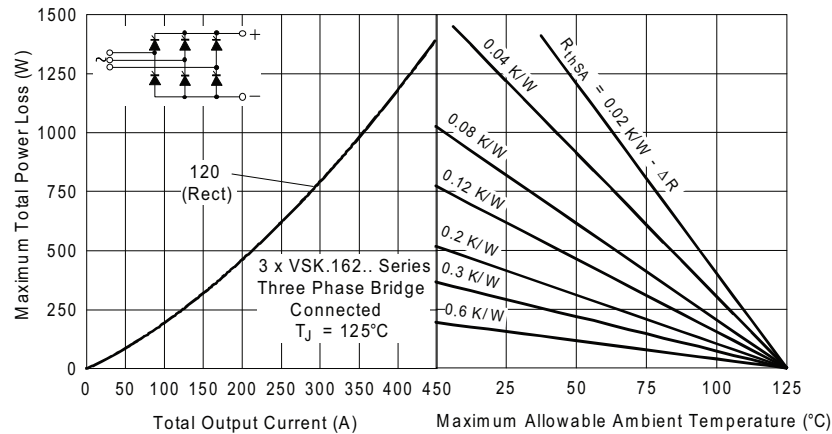

Fig. 27 - On-State Power Loss Characteristics



# VS-VSK.136..PbF, VS-VSK.142..PbF, VS-VSK.162..PbF Series

[www.vishay.com](http://www.vishay.com)

Vishay Semiconductors

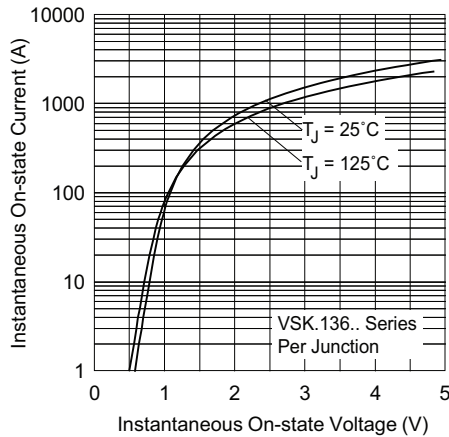

Fig. 28 - On-State Voltage Drop Characteristics

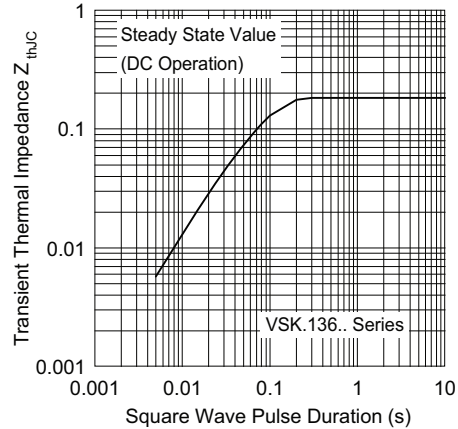

Fig. 31 - Thermal Impedance  $Z_{thJC}$  Characteristics

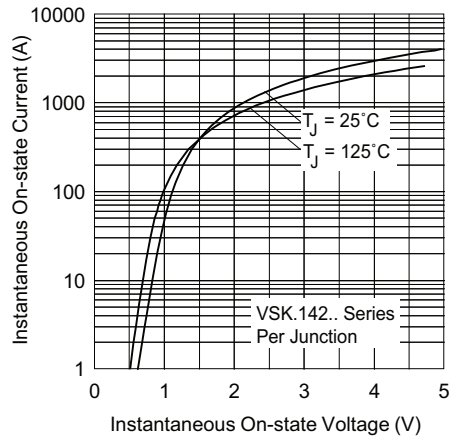

Fig. 29 - On-State Voltage Drop Characteristics

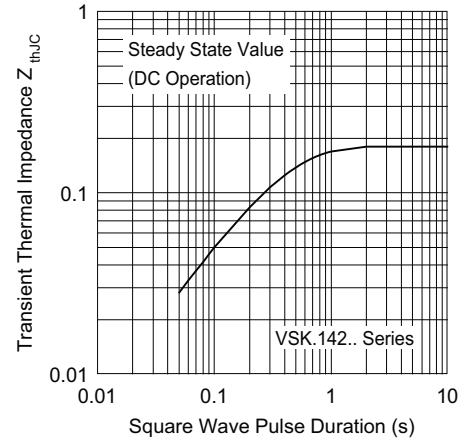

Fig. 32 - Thermal Impedance  $Z_{thJC}$  Characteristics

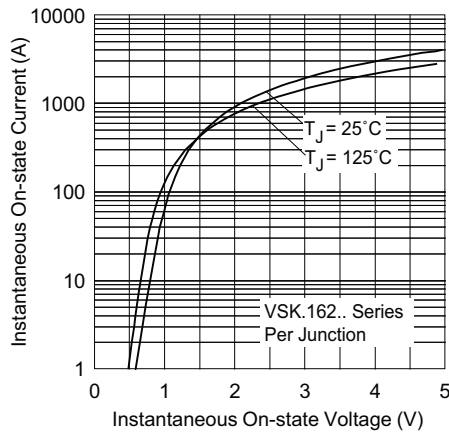

Fig. 30 - On-State Voltage Drop Characteristics

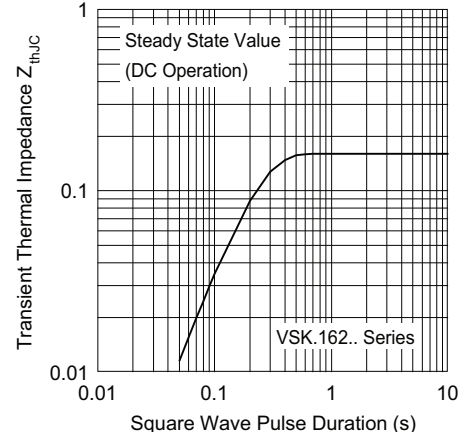

Fig. 33 - Thermal Impedance  $Z_{thJC}$  Characteristics



# VS-VSK.136..PbF, VS-VSK.142..PbF, VS-VSK.162..PbF Series

[www.vishay.com](http://www.vishay.com)

Vishay Semiconductors

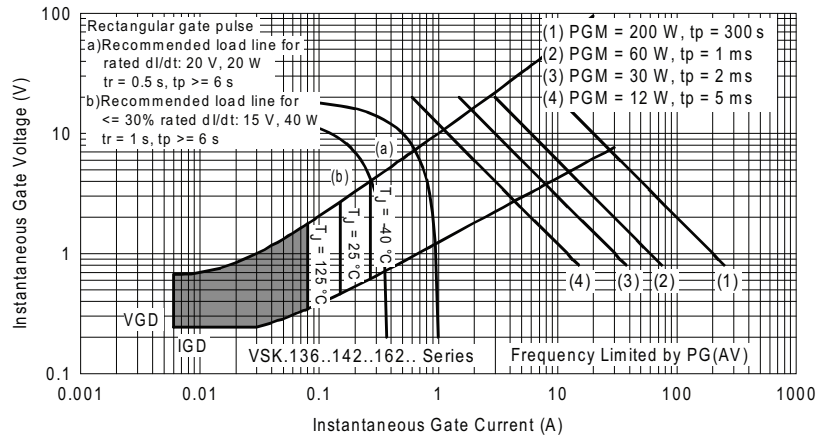

Fig. 34 - Gate Characteristics

## ORDERING INFORMATION TABLE

|             |              |           |                                |           |            |
|-------------|--------------|-----------|--------------------------------|-----------|------------|
| Device code | <b>VS-VS</b> | <b>KT</b> | <b>162</b>                     | <b>16</b> | <b>PbF</b> |
|             | ①            | ②         | ③                              | ④         | ⑤          |
|             | <b>1</b>     | -         | Vishay Semiconductors product  |           |            |
|             | <b>2</b>     | -         | Circuit configuration          |           |            |
|             | <b>3</b>     | -         | Current rating: $I_{T(AV)}$    |           |            |
|             | <b>4</b>     | -         | Voltage code x 100 = $V_{RRM}$ |           |            |
|             | <b>5</b>     | -         | PbF = Lead (Pb)-free           |           |            |

### Note

- To order the optional hardware go to [www.vishay.com/doc?95172](http://www.vishay.com/doc?95172)



**VS-VSK.136..PbF, VS-VSK.142..PbF, VS-VSK.162..PbF Series**

[www.vishay.com](http://www.vishay.com)

Vishay Semiconductors

| CIRCUIT CONFIGURATION                       |                            |                 |
|---|----------------------------|-----------------|
| CIRCUIT DESCRIPTION                         | CIRCUIT CONFIGURATION CODE | CIRCUIT DRAWING |
| Two SCRs doubler circuit                    | T                          |                 |
| SCR/diode doubler circuit, positive control | H                          |                 |
| SCR/diode doubler circuit, negative control | L                          |                 |

| LINKS TO RELATED DOCUMENTS |  |
|----------------------------|--|
| Dimensions                 | <a href="http://www.vishay.com/doc?95067">www.vishay.com/doc?95067</a> |



# Outline Dimensions

Vishay Semiconductors

## INT-A-PAK IGBT/Thyristor

**DIMENSIONS** in millimeters (inches)

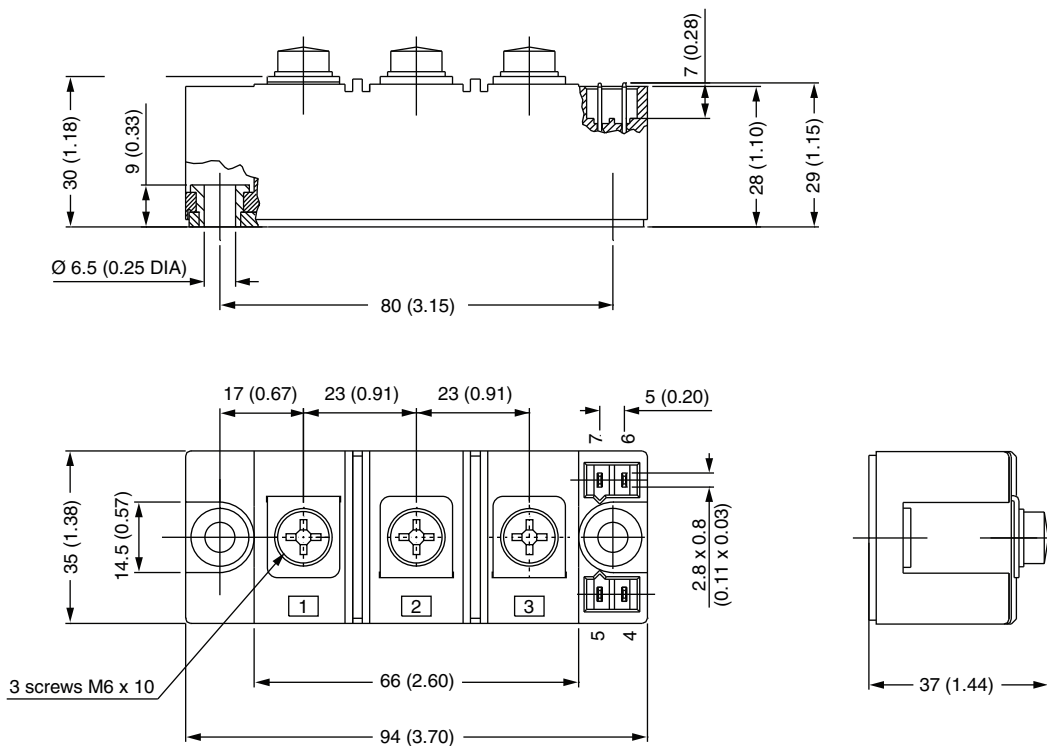



## Disclaimer

ALL PRODUCT, PRODUCT SPECIFICATIONS AND DATA ARE SUBJECT TO CHANGE WITHOUT NOTICE TO IMPROVE RELIABILITY, FUNCTION OR DESIGN OR OTHERWISE.

Vishay Intertechnology, Inc., its affiliates, agents, and employees, and all persons acting on its or their behalf (collectively, "Vishay"), disclaim any and all liability for any errors, inaccuracies or incompleteness contained in any datasheet or in any other disclosure relating to any product.

Vishay makes no warranty, representation or guarantee regarding the suitability of the products for any particular purpose or the continuing production of any product. To the maximum extent permitted by applicable law, Vishay disclaims (i) any and all liability arising out of the application or use of any product, (ii) any and all liability, including without limitation special, consequential or incidental damages, and (iii) any and all implied warranties, including warranties of fitness for particular purpose, non-infringement and merchantability.

Statements regarding the suitability of products for certain types of applications are based on Vishay's knowledge of typical requirements that are often placed on Vishay products in generic applications. Such statements are not binding statements about the suitability of products for a particular application. It is the customer's responsibility to validate that a particular product with the properties described in the product specification is suitable for use in a particular application. Parameters provided in datasheets and / or specifications may vary in different applications and performance may vary over time. All operating parameters, including typical parameters, must be validated for each customer application by the customer's technical experts. Product specifications do not expand or otherwise modify Vishay's terms and conditions of purchase, including but not limited to the warranty expressed therein.

Hyperlinks included in this datasheet may direct users to third-party websites. These links are provided as a convenience and for informational purposes only. Inclusion of these hyperlinks does not constitute an endorsement or an approval by Vishay of any of the products, services or opinions of the corporation, organization or individual associated with the third-party website. Vishay disclaims any and all liability and bears no responsibility for the accuracy, legality or content of the third-party website or for that of subsequent links.

Vishay products are not designed for use in life-saving or life-sustaining applications or any application in which the failure of the Vishay product could result in personal injury or death unless specifically qualified in writing by Vishay. Customers using or selling Vishay products not expressly indicated for use in such applications do so at their own risk. Please contact authorized Vishay personnel to obtain written terms and conditions regarding products designed for such applications.

No license, express or implied, by estoppel or otherwise, to any intellectual property rights is granted by this document or by any conduct of Vishay. Product names and markings noted herein may be trademarks of their respective owners.

## OUR CERTIFICATE

DiGi provide top-quality products and perfect service for customer worldwide through standardization, technological innovation and continuous improvement. DiGi through third-party certification, we stricly control the quality of products and services. Welcome your RFQ to

Email: [Info@DiGi-Electronics.com](mailto:Info@DiGi-Electronics.com)



Tel: +00 852-30501935

RFQ Email: [Info@DiGi-Electronics.com](mailto:Info@DiGi-Electronics.com)

DiGi is a global authorized distributor of electronic components.