

XC4010XL-09BG256C Datasheet

www.digi-electronics.com

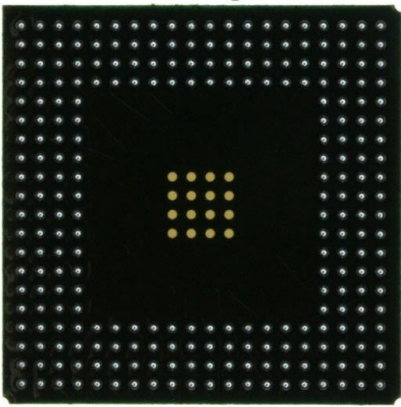

XC4010XL-09BG256C

<https://www.DiGi-Electronics.com>

DiGi Electronics Part Number	XC4010XL-09BG256C-DG
Manufacturer	AMD
Manufacturer Product Number	XC4010XL-09BG256C
Description	IC FPGA 160 I/O 256BGA
Detailed Description	XC4000E/X Field Programmable Gate Array (FPGA) IC 160 12800 950 256-BBGA



Tel: +00 852-30501935

RFQ Email: Info@DiGi-Electronics.com

DiGi is a global authorized distributor of electronic components.

Purchase and inquiry

Manufacturer Product Number:

XC4010XL-09BG256C

Series:

XC4000E/X

DiGi-Electronics Programmable:

Not Verified

Number of Logic Elements/Cells:

950

Number of I/O:

160

Voltage - Supply:

3V ~ 3.6V

Operating Temperature:

0°C ~ 85°C (TJ)

Supplier Device Package:

256-PBGA (27x27)

Manufacturer:

AMD

Product Status:

Obsolete

Number of LABs/CLBs:

400

Total RAM Bits:

12800

Number of Gates:

10000

Mounting Type:

Surface Mount

Package / Case:

256-BBGA

Base Product Number:

XC4010XL

Environmental & Export classification

RoHS Status:

RoHS non-compliant

REACH Status:

REACH Unaffected

HTSUS:

8542.39.0001

Moisture Sensitivity Level (MSL):

3 (168 Hours)

ECCN:

EAR99

XC4000XL Electrical Specifications

Definition of Terms

In the following tables, some specifications may be designated as Advance or Preliminary. These terms are defined as follows:

- Advance:** Initial estimates based on simulation and/or extrapolation from other speed grades, devices, or device families. Values are subject to change. Use as estimates, not for production.
- Preliminary:** Based on preliminary characterization. Further changes are not expected.
- Unmarked:** Specifications not identified as either Advance or Preliminary are to be considered Final.

Except for pin-to-pin input and output parameters, the a.c. parameter delay specifications included in this document are derived from measuring internal test patterns. All specifications are representative of worst-case supply voltage and junction temperature conditions.

All specifications subject to change without notice.

XC4000XL D.C. Characteristics

Absolute Maximum Ratings

	Description		Units	
V_{CC}	Supply voltage relative to Ground	-0.5 to 4.0	V	
V_{IN}	Input voltage relative to Ground (Note 1)	-0.5 to 5.5	V	
V_{TS}	Voltage applied to 3-state output (Note 1)	-0.5 to 5.5	V	
V_{CCt}	Longest Supply Voltage Rise Time from 1 V to 3V	50	ms	
T_{STG}	Storage temperature (ambient)	-65 to +150	°C	
T_{SOL}	Maximum soldering temperature (10 s @ 1/16 in. = 1.5 mm)	+260	°C	
T_J	Junction Temperature	Ceramic packages	+150	°C
		Plastic packages	+125	°C

Note 1: Maximum DC excursion above V_{CC} or below Ground must be limited to either 0.5 V or 10 mA, whichever is easier to achieve. During transitions, the device pins may undershoot to -2.0 V or overshoot to $V_{CC} + 2.0$ V, provided this over or undershoot lasts less than 10 ns and with the forcing current being limited to 200 mA.

Note: Stresses beyond those listed under Absolute Maximum Ratings may cause permanent damage to the device. These are stress ratings only, and functional operation of the device at these or any other conditions beyond those listed under Recommended Operating Conditions is not implied. Exposure to Absolute Maximum Ratings conditions for extended periods of time may affect device reliability.

Recommended Operating Conditions

Symbol	Description	Min	Max	Units	
V_{CC}	Supply voltage relative to Gnd, $T_J = 0$ °C to +85°C	Commercial	3.0	3.6	V
	Supply voltage relative to Gnd, $T_J = -40$ °C to +100°C	Industrial	3.0	3.6	V
V_{IH}	High-level input voltage	50% of V_{CC}	5.5	V	
V_{IL}	Low-level input voltage	0	30% of V_{CC}	V	
T_{IN}	Input signal transition time		250	ns	

Notes: At junction temperatures above those listed above, all delay parameters increase by 0.35% per °C. Input and output measurement threshold is ~50% of V_{CC} .

D.C. Characteristics Over Recommended Operating Conditions

Symbol	Description	Min	Max	Units
V_{OH}	High-level output voltage @ $I_{OH} = -4.0$ mA, V_{CC} min (LVTTL)	2.4		V
	High-level output voltage @ $I_{OH} = -500$ μ A, (LVCMOS)	90% V_{CC}		V
V_{OL}	Low-level output voltage @ $I_{OL} = 12.0$ mA, V_{CC} min (LVTTL) (Note 1)		0.4	V
	Low-level output voltage @ $I_{OL} = 1500$ μ A, (LVCMOS)		10% V_{CC}	V
V_{DR}	Data Retention Supply Voltage (below which configuration data may be lost)	2.5		V
I_{CCO}	Quiescent FPGA supply current (Note 2)		5	mA
I_L	Input or output leakage current	-10	+10	μ A
C_{IN}	Input capacitance (sample tested)	BGA, SBGA, PQ, HQ, MQ packages	10	pF
		PGA packages	16	pF
I_{RPU}	Pad pull-up (when selected) @ $V_{in} = 0$ V (sample tested)	0.02	0.25	mA
I_{RPD}	Pad pull-down (when selected) @ $V_{in} = 3.6$ V (sample tested)	0.02	0.15	mA
I_{RLL}	Horizontal Longline pull-up (when selected) @ logic Low	0.3	2.0	mA

Note 1: With up to 64 pins simultaneously sinking 12 mA.

Note 2: With no output current loads, no active input or Longline pull-up resistors, all I/O pins Tri-stated and floating.

Power-On Power Supply Requirements

Xilinx FPGAs require a minimum rated power supply current capacity to insure proper initialization, and the power supply ramp-up time does affect the current required. A fast ramp-up time requires more current than a slow ramp-up time. The slowest ramp-up time is 50 ms. Current capacity is not specified for a ramp-up time faster than 2ms. The current capacity varies lineally with ramp-up time, *e.g.*, an XC4036XL with a ramp-up time of 25 ms would require a capacity predicted by the point on the straight line drawn from 1A at 120 μ s to 500 mA at 50 ms at the 25 ms time mark. This point is approximately 750 mA .

Product	Description	Ramp-up Time	
		Fast (120 μ s)	Slow (50 ms)
XC4005 - 36XL	Minimum required current supply	1 A	500 mA
XC4044- 62XL	Minimum required current supply	2 A	500 mA
XC4085XL ¹	Minimum required current supply	2 A ¹	500 mA

Notes: 1. The XC4085XL fast ramp-up time is 5 ms.

Devices are guaranteed to initialize properly with the minimum current listed above. A larger capacity power supply may result in a larger initialization current.

This specification applies to Commercial and Industrial grade products only.

Ramp-up Time is measured from 0 V_{DC} to 3.6 V_{DC} . Peak current required lasts less than 3 ms, and occurs near the internal power on reset threshold voltage. After initialization and before configuration, I_{CCmax} is less than 10 mA.

XC4000XL A.C. Characteristics

Testing of the switching parameters is modeled after testing methods specified by MIL-M-38510/605. All devices are 100% functionally tested. Internal timing parameters are derived from measuring internal test patterns. Listed below are representative values where one global clock input drives one vertical clock line in each accessible column, and where all accessible IOB and CLB flip-flops are clocked by the global clock net.

When fewer vertical clock lines are connected, the clock distribution is faster; when multiple clock lines per column are driven from the same global clock, the delay is longer. For more specific, more precise, and worst-case guaranteed data, reflecting the actual routing structure, use the values provided by the static timing analyzer (TRCE in the Xilinx Development System) and back-annotated to the simulation netlist. These path delays, provided as a guideline, have been extracted from the static timing analyzer report. All timing parameters assume worst-case operating conditions (supply voltage and junction temperature). Values apply to all XC4000XL devices and are expressed in nanoseconds unless otherwise noted.

Global Low Skew Buffer to Clock K

Description	Symbol	Speed Grade Device	All	-3	-2	-1	-09	-08	Units
			Min	Max	Max	Max	Max	Max	
Delay from pad through GLS buffer to any clock input, K	T _{GLS}	XC4002XL	0.3	2.1	1.8	1.6	1.5		ns
		XC4005XL	0.4	2.7	2.3	2.0	1.9		ns
		XC4010XL	0.5	3.2	2.8	2.4	2.3		ns
		XC4013XL	0.6	3.6	3.1	2.7	2.6	2.3	ns
		XC4020XL	0.7	4.0	3.5	3.0	2.9		ns
		XC4028XL	0.9	4.4	3.8	3.3	3.2		ns
		XC4036XL	1.1	4.8	4.2	3.6	3.5	3.1	ns
		XC4044XL	1.2	5.3	4.6	4.0	3.9		ns
		XC4052XL	1.3	5.7	5.0	4.5	4.4		ns
		XC4062XL	1.4	6.3	5.4	4.7	4.6	4.0	ns
XC4085XL	1.6	7.2	6.2	5.7	5.5		ns		

Global Early BUFGEs 1, 2, 5, and 6 to IOB Clock

		Speed Grade		All	-3	-2	-1	-09	-08	Units
Description	Symbol	Device	Min	Max	Max	Max	Max	Max	Max	
Delay from pad through GE buffer to any IOB clock input.	T _{GE}	XC4002XL	0.1	1.6	1.4	1.3	1.2			ns
		XC4005XL	0.3	1.9	1.8	1.7	1.6			ns
		XC4010XL	0.3	2.2	1.9	1.7	1.7			ns
		XC4013XL	0.4	2.4	2.1	1.8	1.7	1.5		ns
		XC4020XL	0.4	2.6	2.2	2.1	2.0			ns
		XC4028XL	0.3	2.8	2.4	2.1	2.0			ns
		XC4036XL	0.3	3.1	2.7	2.3	2.2	1.9		ns
		XC4044XL	0.2	3.5	3.0	2.6	2.4			ns
		XC4052XL	0.3	4.0	3.5	3.0	3.0			ns
		XC4062XL	0.3	4.9	4.3	3.7	3.4	3.0		ns
XC4085XL	0.4	5.8	5.1	4.7	4.3			ns		

Global Early BUFGEs 3, 4, 7, and 8 to IOB Clock

		Speed Grade		All	-3	-2	-1	-09	-08	Units
Description	Symbol	Device	Min	Max	Max	Max	Max	Max	Max	
Delay from pad through GE buffer to any IOB clock input.	T _{GE}	XC4002XL	0.5	2.8	2.5	2.1	1.7			ns
		XC4005XL	0.7	3.1	2.8	2.7	2.5			ns
		XC4010XL	0.7	3.5	3.1	2.8	2.7			ns
		XC4013XL	0.7	3.8	3.3	2.9	2.8	2.4		ns
		XC4020XL	0.8	4.1	3.6	3.4	3.2			ns
		XC4028XL	0.9	4.4	3.9	3.4	3.3			ns
		XC4036XL	0.9	4.7	4.2	3.7	3.6	3.1		ns
		XC4044XL	1.0	5.1	4.5	4.0	3.7			ns
		XC4052XL	1.1	5.5	4.8	4.3	4.3			ns
		XC4062XL	1.2	5.9	5.2	4.8	4.5	4.0		ns
XC4085XL	1.3	6.8	6.0	5.5	5.2			ns		



XC4000XL CLB Characteristics

Testing of switching parameters is modeled after testing methods specified by MIL-M-38510/605. All devices are 100% functionally tested. Internal timing parameters are derived from measuring internal test patterns. Listed below are representative values. For more specific, more precise, and worst-case guaranteed data, use the values reported by the static timing analyzer (TRCE in the Xilinx Development System) and back-annotated to the simulation netlist. All timing parameters assume worst-case operating conditions (supply voltage and junction temperature). Values apply to all XC4000XL devices and are expressed in nanoseconds unless otherwise noted.

CLB Switching Characteristic Guidelines

Description	Speed Grade	-3		-2		-1		-09		-08	
		Symbol	Min	Max	Min	Max	Min	Max	Min	Max	Min
Combinatorial Delays											
F/G inputs to X/Y outputs	T_{ILO}		1.6		1.5		1.3		1.2		1.1
F/G inputs via H' to X/Y outputs	T_{IHO}		2.7		2.4		2.2		2.0		1.9
F/G inputs via transparent latch to Q outputs	T_{ITO}		2.9		2.6		2.2		2.0		1.8
C inputs via SR/H0 via H to X/Y outputs	T_{HH0O}		2.5		2.2		2.0		1.8		1.8
C inputs via H1 via H to X/Y outputs	T_{HH1O}		2.4		2.1		1.9		1.6		1.5
C inputs via DIN/H2 via H to X/Y outputs	T_{HH2O}		2.5		2.2		2.0		1.8		1.8
C inputs via EC, DIN/H2 to YQ, XQ output (bypass)	T_{CBYP}		1.5		1.3		1.1		1.0		0.9
CLB Fast Carry Logic											
Operand inputs (F1, F2, G1, G4) to C_{OUT}	T_{OPCY}		2.7		2.3		2.0		1.6		1.6
Add/Subtract input (F3) to C_{OUT}	T_{ASCY}		3.3		2.9		2.5		1.8		1.8
Initialization inputs (F1, F3) to C_{OUT}	T_{INCY}		2.0		1.8		1.5		1.0		0.9
C_{IN} through function generators to X/Y outputs	T_{SUM}		2.8		2.6		2.4		1.7		1.5
C_{IN} to C_{OUT} , bypass function generators	T_{BYP}		0.26		0.23		0.20		0.14		0.14
Carry Net Delay, C_{OUT} to C_{IN}	T_{NET}		0.32		0.28		0.25		0.24		0.24
Sequential Delays											
Clock K to Flip-Flop outputs Q	T_{CKO}		2.1		1.9		1.6		1.5		1.4
Clock K to Latch outputs Q	T_{CKLO}		2.1		1.9		1.6		1.5		1.4
Setup Time before Clock K											
F/G inputs	T_{ICK}	1.1		1.0		0.9		0.8		0.8	
F/G inputs via H	T_{IHCK}	2.2		1.9		1.7		1.6		1.5	
C inputs via H0 through H	T_{HH0CK}	2.0		1.7		1.6		1.4		1.4	
C inputs via H1 through H	T_{HH1CK}	1.9		1.6		1.4		1.2		1.1	
C inputs via H2 through H	T_{HH2CK}	2.0		1.7		1.6		1.4		1.4	
C inputs via DIN	T_{DICK}	0.9		0.8		0.7		0.6		0.6	
C inputs via EC	T_{ECCK}	1.0		0.9		0.8		0.7		0.7	
C inputs via S/R, going Low (inactive)	T_{RCK}	0.6		0.5		0.5		0.4		0.4	
C_{IN} input via F/G	T_{CCK}	2.3		2.1		1.9		1.3		1.2	
C_{IN} input via F/G and H	T_{CHCK}	3.4		3.0		2.7		2.1		2.0	
Hold Time after Clock K											
F/G inputs	T_{CKI}	0		0		0		0		0	
F/G inputs via H	T_{CKIH}	0		0		0		0		0	
C inputs via SR/H0 through H	T_{CKHH0}	0		0		0		0		0	
C inputs via H1 through H	T_{CKHH1}	0		0		0		0		0	
C inputs via DIN/H2 through H	T_{CKHH2}	0		0		0		0		0	
C inputs via DIN/H2	T_{CKDI}	0		0		0		0		0	
C inputs via EC	T_{CKEC}	0		0		0		0		0	
C inputs via SR, going Low (inactive)	T_{CKR}	0		0		0		0		0	
Clock											
Clock High time	T_{CH}	3.0		2.8		2.5		2.3		2.1	
Clock Low time	T_{CL}	3.0		2.8		2.5		2.3		2.1	
Set/Reset Direct											
Width (High)	T_{RPW}	3.0		2.8		2.5		2.3		2.3	
Delay from C inputs via S/R, going High to Q	T_{RIO}		3.7		3.2		2.8		2.7		2.6
Global Set/Reset											
Minimum GSR Pulse Width	T_{MRW}		19.8		17.3		15.0		14.0		14.0
Delay from GSR input to any Q	T_{MRQ}	See Table on page 85 for T_{RRI} values per device.									
Toggle Frequency (MHz) (for export control)	F_{TOG} (MHz)		166		179		200		217		238

CLB Single-Port RAM Synchronous (Edge-Triggered) Write Operation Guidelines

Testing of switching parameters is modeled after testing methods specified by MIL-M-38510/605. All devices are 100% functionally tested. Internal timing parameters are derived from measuring internal test patterns. Listed below are representative values. For more specific, more precise, and worst-case guaranteed data, use the values reported by the static timing analyzer (TRCE in the Xilinx Development System) and back-annotated to the simulation netlist. All timing parameters assume worst-case operating conditions (supply voltage and junction temperature). Values apply to all XC4000XL devices and are expressed in nanoseconds unless otherwise noted.

Single Port RAM	Speed Grade		-3		-2		-1		-09		-08	
	Size	Symbol	Min	Max	Min	Max	Min	Max	Min	Max	Min	Max
Write Operation												
Address write cycle time (clock K period)	16x2	T _{WCS}	9.0		8.4		7.7		7.4		7.4	
	32x1	T _{WCTS}	9.0		8.4		7.7		7.4		7.4	
Clock K pulse width (active edge)	16x2	T _{WPS}	4.5		4.2		3.9		3.7		3.7	
	32x1	T _{WPTS}	4.5		4.2		3.9		3.7		3.7	
Address setup time before clock K	16x2	T _{ASS}	2.2		2.0		1.7		1.7		1.6	
	32x1	T _{ASTS}	2.2		2.0		1.7		1.7		1.7	
Address hold time after clock K	16x2	T _{AHS}	0		0		0		0		0	
	32x1	T _{AHTS}	0		0		0		0		0	
DIN setup time before clock K	16x2	T _{DSS}	2.0		1.9		1.7		1.7		1.7	
	32x1	T _{DSTS}	2.5		2.3		2.1		2.1		2.1	
DIN hold time after clock K	16x2	T _{DHS}	0		0		0		0		0	
	32x1	T _{DHTS}	0		0		0		0		0	
WE setup time before clock K	16x2	T _{WSS}	2.0		1.8		1.6		1.6		1.6	
	32x1	T _{WSTS}	1.8		1.7		1.5		1.5		1.5	
WE hold time after clock K	16x2	T _{WHS}	0		0		0		0		0	
	32x1	T _{WHTS}	0		0		0		0		0	
Data valid after clock K	16x2	T _{WOS}		6.8		6.3		5.8		5.8		5.7
	32x1	T _{WOTS}		8.1		7.5		6.9		6.7		6.7
Read Operation												
Address read cycle time	16x2	T _{RC}	4.5		3.1		2.6		2.6		2.6	
	32x1	T _{RCT}	6.5		5.5		3.8		3.8		3.8	
Data Valid after address change (no Write Enable)	16x2	T _{ILO}		1.6		1.5		1.3		1.2		1.1
	32x1	T _{IHO}		2.7		2.4		2.2		2.0		1.9
Address setup time before clock K	16x2	T _{ICK}	1.1		1.0		0.9		0.8		0.8	
	32x1	T _{IHCK}	2.2		1.9		1.7		1.6		1.5	

CLB Dual-Port RAM Synchronous (Edge-Triggered) Write Operation Guidelines

Testing of switching parameters is modeled after testing methods specified by MIL-M-38510/605. All devices are 100% functionally tested. Internal timing parameters are derived from measuring internal test patterns. Listed below are representative values. For more specific, more precise, and worst-case guaranteed data, use the values reported by the static timing analyzer (TRCE in the Xilinx Development System) and back-annotated to the simulation netlist. All timing parameters assume worst-case operating conditions (supply voltage and junction temperature). Values apply to all XC4000XL devices and are expressed in nanoseconds unless otherwise noted.

Dual Port RAM	Speed Grade		-3		-2		-1		-09		-08	
	Size	Symbol	Min	Max	Min	Max	Min	Max	Min	Max	Min	Max
Address write cycle time (clock K period)	16x1	T _{WCDS}	9.0		8.4		7.7		7.4		7.4	
Clock K pulse width (active edge)	16x1	T _{WPDS}	4.5		4.2		3.9		3.7		3.7	
Address setup time before clock K	16x1	T _{ASDS}	2.5		2.0		1.7		1.7		1.6	
Address hold time after clock K	16x1	T _{AHDS}	0		0		0		0		0	
DIN setup time before clock K	16x1	T _{DSDS}	2.5		2.3		2.0		2.0		2.0	
DIN hold time after clock K	16x1	T _{DHDS}	0		0		0		0		0	
WE setup time before clock K	16x1	T _{WSDS}	1.8		1.7		1.6		1.6		1.6	
WE hold time after clock K	16x1	T _{WHDS}	0		0		0		0		0	
Data valid after clock K	16x1	T _{WODS}		7.8		7.3		6.7		6.7		6.6

CLB RAM Synchronous (Edge-Triggered) Write Timing Waveforms

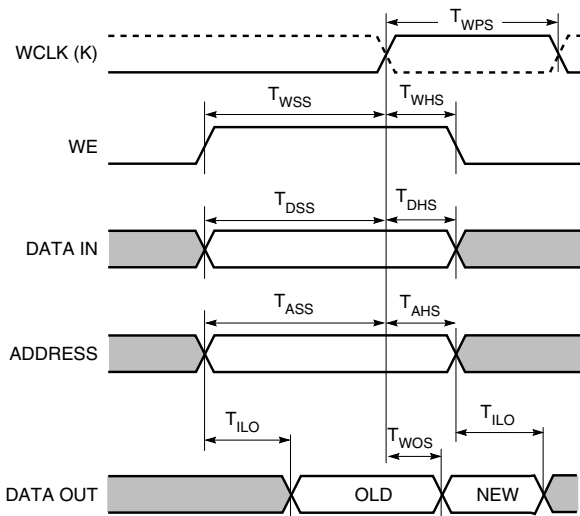

X6461

Single-Port RAM

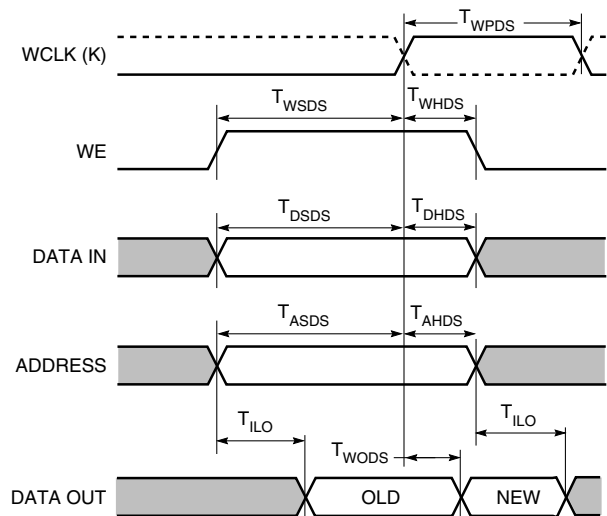

X6474

Dual-Port RAM

XC4000XL Pin-to-Pin Output Parameter Guidelines

Testing of switching parameters is modeled after testing methods specified by MIL-M-38510/605. All devices are 100% functionally tested. Pin-to-pin timing parameters are derived from measuring external and internal test patterns and are guaranteed over worst-case operating conditions (supply voltage and junction temperature). Listed below are representative values for typical pin locations and normal clock loading. For more specific, more precise, and worst-case guaranteed data, reflecting the actual routing structure, use the values provided by the static timing analyzer (TRCE in the Xilinx Development System) and back-annotated to the simulation netlist. These path delays, provided as a guideline, have been extracted from the static timing analyzer report. Values are expressed in nanoseconds unless otherwise noted.

Output Flip-Flop, Clock to Out

Description	Symbol	Device	Speed Grade						Units
			All	-3	-2	-1	-09	-08	
Global Low Skew Clock to Output using Output Flip Flop	T _{ICKOF}	XC4002XL	1.2	7.1	6.1	5.4	5.1		ns
		XC4005XL	1.3	7.7	6.6	5.8	5.4		ns
		XC4010XL	1.4	8.2	7.1	6.2	5.8		ns
		XC4013XL	1.5	8.6	7.4	6.5	6.1	5.6	ns
		XC4020XL	1.6	9.0	7.8	6.8	6.4		ns
		XC4028XL	1.8	9.4	8.1	7.1	6.7		ns
		XC4036XL	2.0	9.8	8.5	7.4	7.0	6.4	ns
		XC4044XL	2.1	10.3	8.9	7.8	7.4		ns
		XC4052XL	2.2	10.7	9.3	8.3	7.9		ns
		XC4062XL	2.3	11.3	9.7	8.5	8.1	7.3	ns
		XC4085XL	2.5	12.2	10.5	9.5	9.0		ns
For output SLOW option add	T _{SLOW}	All Devices	0.5	3.0	2.5	2.0	1.7	1.6	ns

Notes: Clock-to-out minimum delay is measured with the fastest route and the lightest load, Clock-to-out maximum delay is measured using the farthest distance and a reference load of one clock pin (IK or OK) per IOB as well as driving all accessible CLB flip-flops. For designs with a smaller number of clock loads, the pad-to-IOB clock pin delay as determined by the static timing analyzer (TRCE) can be added to the AC parameter Tokpof and used as a worst-case pin-to-pin clock-to-out delay for clocked outputs for FAST mode configurations.

Output timing is measured at ~50% V_{CC} threshold with 50 pF external capacitive load. For different loads, see Figure 1.

Capacitive Load Factor

Figure 1 shows the relationship between I/O output delay and load capacitance. It allows a user to adjust the specified output delay if the load capacitance is different than 50 pF. For example, if the actual load capacitance is 120 pF, add 2.5 ns to the specified delay. If the load capacitance is 20 pF, subtract 0.8 ns from the specified output delay.

Figure 1 is usable over the specified operating conditions of voltage and temperature and is independent of the output slew rate control.

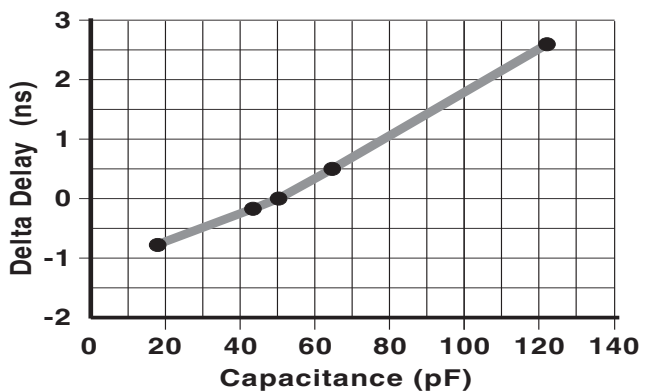

Figure 1: Delay Factor at Various Capacitive Loads

Output Flip-Flop, Clock to Out, BUFGE #s 1, 2, 5, and 6

Description	Symbol	Device	Speed Grade					Units	
			All	-3	-2	-1	-09		-08
			Min	Max	Max	Max	Max	Max	
Global Early Clock to Output using Output Flip Flop. Values are for BUFGE #s 1, 2, 5, and 6.	T _{ICKEOF}	XC4002XL	1.0	6.6	5.7	5.1	4.8		ns
		XC4005XL	1.2	6.9	6.1	5.5	5.2		ns
		XC4010XL	1.2	7.2	6.2	5.5	5.3		ns
		XC4013XL	1.3	7.4	6.4	5.6	5.3	4.8	ns
		XC4020XL	1.3	7.6	6.5	5.9	5.6		ns
		XC4028XL	1.2	7.8	6.7	5.9	5.6		ns
		XC4036XL	1.2	8.1	7.0	6.1	5.8	5.2	ns
		XC4044XL	1.1	8.5	7.3	6.4	6.0		ns
		XC4052XL	1.2	9.0	7.8	6.8	6.6		ns
		XC4062XL	1.2	9.9	8.6	7.5	7.0	6.3	ns
XC4085XL	1.3	10.8	9.4	8.5	7.9		ns		

Notes: Clock-to-out minimum delay is measured with the fastest route and the lightest load, Clock-to-out maximum delay is measured using the farthest distance and a reference load of one clock pin (IK or OK) per IOB as well as driving all accessible CLB flip-flops. For designs with a smaller number of clock loads, the pad-to-IOB clock pin delay as determined by the static timing analyzer (TRCE) can be added to the AC parameter Tokpof and used as a worst-case pin-to-pin clock-to-out delay for clocked outputs for FAST mode configurations.

Output timing is measured at ~50% V_{CC} threshold with 50 pF external capacitive load. For different loads, see Figure 1.

Output Flip-Flop, Clock to Out, BUFGE #s 3, 4, 7, and 8

Description	Symbol	Device	Speed Grade					Units	
			All	-3	-2	-1	-09		-08
			Min	Max	Max	Max	Max	Max	
Global Early Clock to Output using Output Flip Flop. Values are for BUFGE #s 3, 4, 7, and 8.	T _{ICKEOF}	XC4002XL	1.3	7.8	6.8	5.9	5.3		ns
		XC4005XL	1.5	8.1	7.1	6.5	6.1		ns
		XC4010XL	1.6	8.5	7.4	6.6	6.3		ns
		XC4013XL	1.6	8.8	7.6	6.7	6.4	5.7	ns
		XC4020XL	1.7	9.1	7.9	7.2	6.8		ns
		XC4028XL	1.7	9.4	8.2	7.2	6.9		ns
		XC4036XL	1.8	9.7	8.5	7.5	7.2	6.4	ns
		XC4044XL	1.9	10.1	8.8	7.8	7.3		ns
		XC4052XL	2.0	10.5	9.1	8.1	7.9		ns
		XC4062XL	2.0	10.9	9.5	8.6	8.1	7.3	ns
XC4085XL	2.2	11.8	10.3	9.3	8.8		ns		

Notes: Clock-to-out minimum delay is measured with the fastest route and the lightest load, Clock-to-out maximum delay is measured using the farthest distance and a reference load of one clock pin (IK or OK) per IOB as well as driving all accessible CLB flip-flops. For designs with a smaller number of clock loads, the pad-to-IOB clock pin delay as determined by the static timing analyzer (TRCE) can be added to the AC parameter Tokpof and used as a worst-case pin-to-pin clock-to-out delay for clocked outputs for FAST mode configurations.

Output timing is measured at ~50% V_{CC} threshold with 50 pF external capacitive load. For different loads, see Figure 1.

XC4000XL Pin-to-Pin Input Parameter Guidelines

Testing of switching parameters is modeled after testing methods specified by MIL-M-38510/605. All devices are 100% functionally tested. Pin-to-pin timing parameters are derived from measuring external and internal test patterns and are guaranteed over worst-case operating conditions (supply voltage and junction temperature). Listed below are representative values for typical pin locations and normal clock loading. For more specific, more precise, and worst-case guaranteed data, reflecting the actual routing structure, use the values provided by the static timing analyzer (TRCE in the Xilinx Development System) and back-annotated to the simulation netlist. These path delays, provided as a guideline, have been extracted from the static timing analyzer report. Values are expressed in nanoseconds unless otherwise noted

Global Low Skew Clock, Set-Up and Hold

Description	Symbol	Device	Speed Grade					Units
			-3	-2	-1	-09	-08	
			Min	Min	Min	Min	Min	
Input Setup and Hold Times								
No Delay Global Low Skew Clock and IFF Global Low Skew Clock and FCL	T_{PSN}/T_{PHN}	XC4002XL	2.5 / 1.5	2.2 / 1.3	1.9 / 1.2	1.7 / 1.0		ns
		XC4005XL	1.2 / 2.6	1.1 / 2.2	0.9 / 2.0	0.8 / 1.7		ns
		XC4010XL	1.2 / 3.0	1.1 / 2.6	0.9 / 2.3	0.8 / 2.0		ns
		XC4013XL	1.2 / 3.2	1.1 / 2.8	0.9 / 2.4	0.8 / 2.1	0.8 / 2.1	ns
		XC4020XL	1.2 / 3.7	1.1 / 3.2	0.9 / 2.8	0.8 / 2.4		ns
		XC4028XL	1.2 / 4.4	1.1 / 3.8	0.9 / 3.3	0.8 / 2.9		ns
		XC4036XL	1.2 / 5.5	1.1 / 4.8	0.9 / 4.1	0.8 / 3.6	0.8 / 3.6	ns
		XC4044XL	1.2 / 5.8	1.1 / 5.0	0.9 / 4.4	0.8 / 3.8		ns
		XC4052XL	1.2 / 7.1	1.1 / 6.2	0.9 / 5.4	0.8 / 4.7		ns
		XC4062XL	1.2 / 7.0	1.1 / 6.1	0.9 / 5.3	0.8 / 4.6	0.8 / 4.6	ns
XC4085XL	1.2 / 9.4	1.1 / 8.2	0.9 / 7.1	0.8 / 6.2		ns		
Partial Delay Global Low Skew Clock and IFF Global Low Skew Clock and FCL	T_{PSP}/T_{PHP}	XC4002XL	8.4 / 0.0	7.3 / 0.0	6.3 / 0.0	5.5 / 0.0		ns
		XC4005XL	10.5 / 0.0	9.1 / 0.0	7.9 / 0.0	6.9 / 0.0		ns
		XC4010XL	11.1 / 0.0	9.7 / 0.0	8.4 / 0.0	7.3 / 0.0		ns
		XC4013XL*	6.1 / 1.0	5.3 / 1.0	4.6 / 1.0	4.0 / 1.0	3.7 / 0.5	ns
		XC4020XL	11.9 / 1.0	10.3 / 1.0	9.0 / 1.0	7.8 / 1.0		ns
		XC4028XL	12.3 / 1.0	10.7 / 1.0	9.3 / 1.0	8.1 / 1.0		ns
		XC4036XL*	6.4 / 1.0	5.6 / 1.0	4.8 / 1.0	4.2 / 1.0	4.0 / 0.8	ns
		XC4044XL	13.1 / 1.0	11.4 / 1.0	9.9 / 1.0	8.6 / 1.0		ns
		XC4052XL	11.9 / 1.0	10.3 / 1.0	9.0 / 1.0	7.8 / 1.0		ns
		XC4062XL*	6.7 / 1.2	5.8 / 1.2	5.1 / 1.2	4.4 / 1.2	4.2 / 1.0	ns
XC4085XL	12.9 / 1.2	11.2 / 1.2	9.8 / 1.2	8.5 / 1.2		ns		
Full Delay Global Low Skew Clock and IFF	T_{PSD}/T_{PHD}	XC4002XL	6.8 / 0.0	6.0 / 0.0	5.2 / 0.0	4.5 / 0.0		ns
		XC4005XL	8.8 / 0.0	7.6 / 0.0	6.6 / 0.0	5.6 / 0.0		ns
		XC4010XL	9.0 / 0.0	7.8 / 0.0	6.8 / 0.0	5.8 / 0.0		ns
		XC4013XL*	6.4 / 0.0	6.0 / 0.0	5.6 / 0.0	4.8 / 0.0	4.8 / 0.0	ns
		XC4020XL	8.8 / 0.0	7.6 / 0.0	6.6 / 0.0	6.2 / 0.0		ns
		XC4028XL	9.3 / 0.0	8.1 / 0.0	7.0 / 0.0	6.4 / 0.0		ns
		XC4036XL*	6.6 / 0.0	6.2 / 0.0	5.8 / 0.0	5.3 / 0.0	5.3 / 0.0	ns
		XC4044XL	10.6 / 0.0	9.2 / 0.0	8.0 / 0.0	6.8 / 0.0		ns
		XC4052XL	11.2 / 0.0	9.7 / 0.0	8.4 / 0.0	7.0 / 0.0		ns
		XC4062XL*	6.8 / 0.0	6.4 / 0.0	6.0 / 0.0	5.5 / 0.0	5.5 / 0.0	ns
XC4085XL	12.7 / 0.0	11.0 / 0.0	9.6 / 0.0	8.4 / 0.0		ns		

IFF = Input Flip-Flop or Latch

* The XC4013XL, XC4036XL, and 4062XL have significantly faster partial and full delay setup times than other devices.

Notes: Input setup time is measured with the fastest route and the lightest load.

Input hold time is measured using the furthest distance and a reference load of one clock pin per IOB as well as driving all accessible CLB flip-flops. For designs with a smaller number of clock loads, the pad-to-IOB clock pin delay as determined by the static timing analyzer (TRCE) can be used as a worst-case pin-to-pin no-delay input hold specification.

Global Early Clock BUFGEs 1, 2, 5, and 6 Set-up and Hold for IFF and FCL

Description	Symbol	Device	Speed Grade	-3	-2	-1	-09	-08	Units
			Min	Min	Min	Min	Min		
Input Setup and Hold Times									
No Delay Global Early Clock and IFF Global Early Clock and FCL	T_{PSEN}/T_{PHEN} T_{PFSEN}/T_{PFHEN}	XC4002XL	2.8 / 1.5	2.5 / 1.3	2.2 / 1.2	1.9 / 1.0			ns
		XC4005XL	1.2 / 4.1	1.1 / 3.6	0.9 / 3.1	0.8 / 2.7			ns
		XC4010XL	1.2 / 4.4	1.1 / 3.8	0.9 / 3.3	0.8 / 2.9			ns
		XC4013XL	1.2 / 4.7	1.1 / 4.1	0.9 / 3.6	0.8 / 3.1	0.5 / 2.7		ns
		XC4020XL	1.2 / 4.6	1.1 / 4.0	0.9 / 3.5	0.8 / 3.0			ns
		XC4028XL	1.2 / 5.3	1.1 / 4.6	0.9 / 4.0	0.8 / 3.5			ns
		XC4036XL	1.2 / 6.7	1.1 / 5.8	0.9 / 5.1	0.8 / 4.4	0.5 / 3.7		ns
		XC4044XL	1.2 / 6.5	1.1 / 5.7	0.9 / 4.9	0.8 / 4.3			ns
		XC4052XL	1.2 / 6.7	1.1 / 5.8	0.9 / 5.1	0.8 / 4.4			ns
		XC4062XL	1.2 / 8.4	1.1 / 7.3	0.9 / 6.3	0.8 / 5.5	0.5 / 4.7		ns
XC4085XL	1.2 / 8.7	1.1 / 7.5	0.9 / 6.6	0.8 / 5.7			ns		
Partial Delay Global Early Clock and IFF Global Early Clock and FCL	T_{PSEP}/T_{PHEP} T_{PFSEP}/T_{PFHEP}	XC4002XL	8.1 / 0.9	7.0 / 0.8	6.1 / 0.7	5.3 / 0.6			ns
		XC4005XL	9.0 / 0.0	8.5 / 0.0	8.0 / 0.0	7.5 / 0.0			ns
		XC4010XL	11.9 / 0.0	10.4 / 0.0	9.0 / 0.0	8.0 / 0.0			ns
		XC4013XL*	6.4 / 0.0	5.9 / 0.0	5.4 / 0.0	4.9 / 0.0	4.4 / 0.0		ns
		XC4020XL	10.8 / 0.0	10.3 / 0.0	9.8 / 0.0	9.0 / 0.0			ns
		XC4028XL	14.0 / 0.0	12.2 / 0.0	10.6 / 0.0	9.8 / 0.0			ns
		XC4036XL*	7.0 / 0.0	6.6 / 0.0	6.2 / 0.0	5.2 / 0.0	4.7 / 0.0		ns
		XC4044XL	14.6 / 0.0	12.7 / 0.0	11.0 / 0.0	10.8 / 0.0			ns
		XC4052XL	16.4 / 0.0	14.3 / 0.0	12.4 / 0.0	11.4 / 0.0			ns
		XC4062XL*	9.0 / 0.8	8.6 / 0.8	8.2 / 0.8	7.0 / 0.8	6.3 / 0.5		ns
XC4085XL	16.7 / 0.0	14.5 / 0.0	12.6 / 0.0	11.6 / 0.0			ns		
Full Delay Global Early Clock and IFF	T_{PSED}/T_{PHED}	XC4002XL	6.7 / 0.0	5.8 / 0.0	5.1 / 0.0	4.4 / 0.0			ns
		XC4005XL	10.8 / 0.0	9.4 / 0.0	8.2 / 0.0	7.1 / 0.0			ns
		XC4010XL	10.3 / 0.0	9.0 / 0.0	7.8 / 0.0	6.8 / 0.0			ns
		XC4013XL*	10.0 / 0.0	8.7 / 0.0	7.6 / 0.0	6.6 / 0.0	6.0 / 0.0		ns
		XC4020XL	12.0 / 0.0	10.4 / 0.0	9.1 / 0.0	7.9 / 0.0			ns
		XC4028XL	12.6 / 0.0	11.0 / 0.0	9.5 / 0.0	8.3 / 0.0			ns
		XC4036XL*	12.2 / 0.0	10.6 / 0.0	9.2 / 0.0	8.0 / 0.0	7.2 / 0.0		ns
		XC4044XL	13.8 / 0.0	12.0 / 0.0	10.5 / 0.0	9.1 / 0.0			ns
		XC4052XL	14.1 / 0.0	12.3 / 0.0	10.7 / 0.0	9.3 / 0.0			ns
		XC4062XL*	13.1 / 0.0	11.4 / 0.0	9.9 / 0.0	8.6 / 0.0	7.8 / 0.0		ns
XC4085XL	17.9 / 0.0	15.6 / 0.0	13.6 / 0.0	11.8 / 0.0			ns		

IFF = Input Flip-Flop or Latch, FCL = Fast Capture Latch

* The XC4013XL, XC4036XL, and 4062XL have significantly faster partial and full delay setup times than other devices.

Notes: Input setup time is measured with the fastest route and the lightest load.

Input hold time is measured using the furthest distance and a reference load of one clock pin per IOB as well as driving all accessible CLB flip-flops. For designs with a smaller number of clock loads, the pad-to-IOB clock pin delay as determined by the static timing analyzer (TRCE) can be used as a worst-case pin-to-pin no-delay input hold specification.



Global Early Clock BUFGEs 3, 4, 7, and 8 Set-up and Hold for IFF and FCL

Description	Symbol	Speed Grade Device	-3	-2	-1	-09	-08	Units
			Min	Min	Min	Min	Min	
Input Setup & Hold Times								
No Delay Global Early Clock and IFF Global Early Clock and FCL	T_{PSEN}/T_{PHEN} T_{PFSEN}/T_{PFHEN}	XC4002XL	3.0 / 2.0	2.6 / 1.7	2.3 / 1.5	2.0 / 1.3		ns
		XC4005XL	1.2 / 4.1	1.1 / 3.6	0.9 / 3.1	0.8 / 2.7		ns
		XC4010XL	1.2 / 4.4	1.1 / 3.8	0.9 / 3.3	0.8 / 2.9		ns
		XC4013XL	1.2 / 4.7	1.1 / 4.1	0.9 / 3.6	0.8 / 3.1	0.5 / 2.7	ns
		XC4020XL	1.2 / 4.6	1.1 / 4.0	0.9 / 3.5	0.8 / 3.0		ns
		XC4028XL	1.2 / 5.3	1.1 / 4.6	0.9 / 4.0	0.8 / 3.5		ns
		XC4036XL	1.2 / 6.7	1.1 / 5.8	0.9 / 5.1	0.8 / 4.4	0.5 / 3.7	ns
		XC4044XL	1.2 / 6.5	1.1 / 5.7	0.9 / 4.9	0.8 / 4.3		ns
		XC4052XL	1.2 / 6.7	1.1 / 5.8	0.9 / 5.1	0.8 / 4.4		ns
		XC4062XL	1.2 / 8.4	1.1 / 7.3	0.9 / 6.3	0.8 / 5.5	0.5 / 4.7	ns
XC4085XL	1.2 / 8.7	1.1 / 7.5	0.9 / 6.6	0.8 / 5.7		ns		
Partial Delay Global Early Clock and IFF Global Early Clock and FCL	T_{PSEP}/T_{PHEP} T_{PFSEP}/T_{PFHEP}	XC4002XL	7.3 / 1.5	6.4 / 1.3	5.5 / 1.2	4.8 / 1.0		ns
		XC4005XL	8.4 / 0.0	7.9 / 0.0	7.4 / 0.0	7.2 / 0.0		ns
		XC4010XL	10.3 / 0.0	9.0 / 0.0	7.8 / 0.0	7.4 / 0.0		ns
		XC4013XL*	5.4 / 0.0	4.9 / 0.0	4.4 / 0.0	4.3 / 0.0	4.0 / 0.0	ns
		XC4020XL	9.8 / 0.0	9.3 / 0.0	8.8 / 0.0	8.5 / 0.0		ns
		XC4028XL	12.7 / 0.0	11.0 / 0.0	9.6 / 0.0	9.3 / 0.0		ns
		XC4036XL*	6.4 / 0.8	5.9 / 0.8	5.4 / 0.8	5.0 / 0.8	4.6 / 0.2	ns
		XC4044XL	13.8 / 0.0	12.0 / 0.0	10.4 / 0.0	10.2 / 0.0		ns
		XC4052XL	14.5 / 0.0	12.7 / 0.0	11.0 / 0.0	10.7 / 0.0		ns
		XC4062XL*	8.4 / 1.5	7.9 / 1.5	7.4 / 1.5	6.8 / 1.5	6.2 / 0.0	ns
XC4085XL	14.5 / 0.0	12.7 / 0.0	11.0 / 0.0	10.8 / 0.0		ns		
Full Delay Global Early Clock and IFF	T_{PSED}/T_{PHED}	XC4002XL	5.9 / 0.0	5.2 / 0.0	4.5 / 0.0	3.9 / 0.0		ns
		XC4005XL	10.8 / 0.0	9.4 / 0.0	8.2 / 0.0	7.1 / 0.0		ns
		XC4010XL	10.3 / 0.0	9.0 / 0.0	7.8 / 0.0	6.8 / 0.0		ns
		XC4013XL*	10.0 / 0.0	8.7 / 0.0	7.6 / 0.0	6.6 / 0.0	6.0 / 0.0	ns
		XC4020XL	12.0 / 0.0	10.4 / 0.0	9.1 / 0.0	7.9 / 0.0		ns
		XC4028XL	12.6 / 0.0	11.0 / 0.0	9.5 / 0.0	8.3 / 0.0		ns
		XC4036XL*	12.2 / 0.0	10.6 / 0.0	9.2 / 0.0	8.0 / 0.0	7.2 / 0.0	ns
		XC4044XL	13.8 / 0.0	12.0 / 0.0	10.5 / 0.0	9.1 / 0.0		ns
		XC4052XL	14.1 / 0.0	12.3 / 0.0	10.7 / 0.0	9.3 / 0.0		ns
		XC4062XL*	13.1 / 0.0	11.4 / 0.0	9.9 / 0.0	8.6 / 0.0	7.8 / 0.0	ns
XC4085XL	17.9 / 0.0	15.6 / 0.0	13.6 / 0.0	11.8 / 0.0		ns		

* The XC4013XL, XC4036XL, and 4062XL have significantly faster partial and full delay setup times than other devices.

IFF = Input Flip Flop or Latch. FCL = Fast Capture Latch

Notes: Input setup time is measured with the fastest route and the lightest load.

Input hold time is measured using the furthest distance and a reference load of one clock pin per IOB as well as driving all accessible CLB flip-flops. For designs with a smaller number of clock loads, the pad-to-IOB clock pin delay as determined by the static timing analyzer (TRCE) can be used as a worst-case pin-to-pin no-delay input hold specification.

XC4000XL IOB Input Switching Characteristic Guidelines

Testing of switching parameters is modeled after testing methods specified by MIL-M-38510/605. All devices are 100% functionally tested. Internal timing parameters are derived from measuring internal test patterns. Listed below are representative values. For more specific, more precise, and worst-case guaranteed data, use the values reported by the static timing analyzer (TRCE in the Xilinx Development System) and back-annotated to the simulation netlist. These path delays, provided as a guideline, have been extracted from the static timing analyzer report. All timing parameters assume worst-case operating conditions (supply voltage and junction temperature).

Description	Symbol	Speed Grade Device	-3	-2	-1	-09	-08	Units
			Min	Min	Min	Min	Min	
Clocks								
Clock Enable (EC) to Clock (IK)	T _{ECIK}	All devices	0.1	0.1	0.1	0.1	0.1	ns
Delay from FCL enable (OK) active edge to IFF clock (IK) active edge	T _{OKIK}	XC4002XL	3.0	2.7	2.3	2.3		ns
		XC4013, 36, 62XL	2.2	1.9	1.6	1.6	1.6	ns
		Balance of Family	2.2	1.9	1.6	1.6		ns
Setup Times								
Pad to Clock (IK), no delay	T _{PICK}	XC4002XL	2.6	2.3	2.0	2.0		ns
		XC4013, 36, 62XL	1.7	1.5	1.3	1.3	1.2	ns
		Balance of Family	1.7	1.5	1.3	1.3		ns
Pad to Clock (IK), via transparent Fast Capture Latch, no delay	T _{PICKF}	XC4002XL	3.2	2.9	2.5	2.4		ns
		XC4013, 36, 62XL	2.3	2.0	1.8	1.7	1.6	ns
		Balance of Family	2.3	2.0	1.8	1.7		ns
Pad to Fast Capture Latch Enable (OK), no delay	T _{POCK}	XC4013, 36, 62XL Balance of Family	1.2 1.2	1.0 1.0	0.9 0.9	0.9 0.9	0.9	ns ns
Hold Times								
All Hold Times		All Devices	0	0	0	0	0	
Global Set/Reset								
Minimum GSR Pulse Width	T _{MRW}	All devices	19.8	17.3	15.0	14.0	14.0	ns
Global Set/Reset								
Delay from GSR input to any Q	T _{RR1*}	XC4002XL	9.8	8.5	7.4	7.0		ns
		XC4005XL	11.3	9.8	8.5	8.1		ns
		XC4010XL	13.9	12.1	10.5	10.0		ns
		XC4013XL	15.9	13.8	12.0	11.4	10.9	ns
		XC4020XL	18.6	16.1	14.0	13.3		ns
		XC4028XL	20.5	17.9	15.5	14.3		ns
		XC4036XL	22.5	19.6	17.0	16.2	16.2	ns
		XC4044XL	25.1	21.9	19.0	18.1		ns
		XC4052XL	27.2	23.6	20.5	19.5		ns
		XC4062XL	29.1	25.3	22.0	20.9	20.4	ns
XC4085XL	34.4	29.9	26.0	24.7		ns		
Propagation Delays								
Pad to I1, I2	T _{PID}	All devices	1.6	1.4	1.2	1.1	1.0	ns
Pad to I1, I2 via transparent input latch, no delay	T _{PLI}	XC4002XL	4.7	4.2	3.6	3.5		ns
		XC4013, 36, 62XL	3.1	2.7	2.4	2.2	2.1	ns
		Balance of Family	3.1	2.7	2.4	2.2		ns
Pad to I1, I2 via transparent FCL and input latch, no delay	T _{PFLLI}	X4002XL	5.4	4.7	4.1	3.9		ns
		XC4013, 36, 62XL	3.7	3.3	2.8	2.7	2.5	ns
		Balance of Family	3.7	3.3	2.8	2.7		ns
Clock (IK) to I1, I2 (flip-flop)	T _{IKRI}	All devices	1.7	1.5	1.3	1.2	1.2	ns
Clock (IK) to I1, I2 (latch enable, active Low)	T _{IKLI}	All devices	1.8	1.6	1.4	1.3	1.3	ns
	T _{OKLI}	XC4002XL	5.2	4.6	4.0	3.8		ns
FCL Enable (OK) active edge to I1, I2 (via transparent standard input latch)		XC4013, 36, 62XL	3.6	3.1	2.7	2.6	2.5	ns
		Balance of Family	3.6	3.1	2.7	2.6		ns

IFF = Input Flip-Flop or Latch, FCL = Fast Capture Latch

* Indicates Minimum Amount of Time to Assure Valid Data.

XC4000XL IOB Output Switching Characteristic Guidelines

Testing of switching parameters is modeled after testing methods specified by MIL-M-38510/605. All devices are 100% functionally tested. Internal timing parameters are derived from measuring internal test patterns. Listed below are representative values. For more specific, more precise, and worst-case guaranteed data, use the values reported by the static timing analyzer (TRCE in the Xilinx Development System) and back-annotated to the simulation netlist. These path delays, provided as a guideline, have been extracted from the static timing analyzer report. All timing parameters assume worst-case operating conditions (supply voltage and junction temperature). For Propagation Delays, slew-rate = fast unless otherwise noted. Values are expressed in nanoseconds unless otherwise noted.

		-3		-2		-1		-09		-08	
Description	Symbol	Min	Max	Min	Max	Min	Max	Min	Max	Min	Max
Clocks											
Clock High	T _{CH}	3.0		2.8		2.5		2.3		2.1	
Clock Low	T _{CL}	3.0		2.8		2.5		2.3		2.1	
Propagation Delays											
Clock (OK) to Pad	T _{OKPOF}		5.0		4.3		3.8		3.5		3.3
Output (O) to Pad	T _{OPF}		4.1		3.6		3.1		3.0		2.8
3-state to Pad hi-Z (slew-rate independent)	T _{TSHZ}		4.0		3.5		3.0		2.9		2.9
3-state to Pad active and valid	T _{TSONF}		4.4		3.8		3.3		3.3		3.3
Output (O) to Pad via Fast Output MUX	T _{OFFPF}		5.5		4.8		4.2		4.0		3.7
Select (OK) to Pad via Fast MUX	T _{OKFPF}		5.1		4.5		3.9		3.7		3.4
Setup and Hold Times											
Output (O) to clock (OK) setup time	T _{OOK}	0.5		0.4		0.3		0.3		0.3	
Output (O) to clock (OK) hold time	T _{OKO}	0.0		0.0		0.0		0.0		0.0	
Clock Enable (EC) to clock (OK) setup time	T _{ECCOK}	0.0		0.0		0.0		0.0		0.0	
Clock Enable (EC) to clock (OK) hold time	T _{OKEC}	0.3		0.2		0.1		0.0		0.0	
Global Set/Reset											
Minimum GSR pulse width	T _{MRW}	19.8		17.3		15.0		14.0		14.0	
Delay from GSR input to any Pad	T _{RPO*}										
XC4002XL			14.3		12.5		10.9		10.3		
XC4005XL			15.9		13.8		12.0		11.4		
XC4010XL			18.5		16.1		14.0		13.3		
XC4013XL			20.5		17.8		15.5		14.7		14.0
XC4020XL			23.2		20.1		17.5		16.6		
XC4028XL			25.1		21.9		19.0		17.6		
XC4036XL			27.1		23.6		20.5		19.4		19.3
XC4044XL			29.7		25.9		22.5		21.4		
XC4052XL			31.7		27.6		24.0		22.8		
XC4062XL			33.7		29.3		25.5		24.2		23.5
XC4085XL			39.0		33.9		29.5		28.0		
Slew Rate Adjustment											
For output SLOW option add	T _{SLOW}		3.0		2.5		2.0		1.7		1.6

Note: Output timing is measured at ~50% V_{CC} threshold, with 50 pF external capacitive loads.

* Indicates Minimum Amount of Time to Assure Valid Data.

Revision Control

Version	Nature of Changes
02/01/1999 (1.5)	Release included in the 1999 data book, section 6
05/14/1999 (1.6)	Replaced Electrical Specification and pinout pages for E, EX, and XL families with separate updates and added URL link on placeholder page for electrical specifications/pinouts for WebLINX users
09/30/1999 (1.7)	Added Power-on specification.
10/18/1999 (1.8)	Corrected posted file to include missing page (IOB Output Parameters).
03/01/2013 (2.0)	The products listed in this data sheet are obsolete. See XCN08011 for further information.

OUR CERTIFICATE

DiGi provide top-quality products and perfect service for customer worldwide through standardization, technological innovation and continuous improvement. DiGi through third-party certification, we strictly control the quality of products and services. Welcome your RFQ to

Email: Info@DiGi-Electronics.com



Tel: +00 852-30501935

RFQ Email: Info@DiGi-Electronics.com

DiGi is a global authorized distributor of electronic components.