

XCR3512XL-10PQG208C Datasheet

www.digi-electronics.com



XCR3512XL-10PQG208C

<https://www.DiGi-Electronics.com>

DiGi Electronics Part Number	XCR3512XL-10PQG208C-DG
Manufacturer	AMD
Manufacturer Product Number	XCR3512XL-10PQG208C
Description	IC CPLD 512MC 9NS 208QFP
Detailed Description	Embedded, Integrated Circuits (ICs)



Tel: +00 852-30501935

RFQ Email: Info@DiGi-Electronics.com

DiGi is a global authorized distributor of electronic components.

Purchase and inquiry

Manufacturer Product Number:

XCR3512XL-10PQG208C

Series:

CoolRunner XPLA3

DiGi-Electronics Programmable:

Not Verified

Delay Time tpd(1) Max:

9 ns

Number of Logic Elements/Blocks:

32

Number of Gates:

12000

Operating Temperature:

0°C ~ 70°C (TA)

Package / Case:

208-BFQFP

Base Product Number:

XCR3512

Manufacturer:

AMD

Product Status:

Obsolete

Programmable Type:

In System Programmable (min 1K program/erase cycles)

Voltage Supply - Internal:

3V ~ 3.6V

Number of Macrocells:

512

Number of I/O:

180

Mounting Type:

Surface Mount

Supplier Device Package:

208-PQFP (28x28)

Environmental & Export classification

RoHS Status:

ROHS3 Compliant

REACH Status:

REACH Unaffected

HTSUS:

8542.39.0001

Moisture Sensitivity Level (MSL):

3 (168 Hours)

ECCN:

EAR99



XCR3512XL: 512 Macrocell CPLD

DS081 (v2.0) March 31, 2006

Product Specification

Features

- Low power 3.3V 512 macrocell CPLD
- 7.0 ns pin-to-pin logic delays
- System frequencies up to 135 MHz
- 512 macrocells with 12,000 usable gates
- Available in small footprint packages
 - 208-pin PQFP (180 user I/O)
 - 256-ball FBGA (212 user I/O)
 - 324-ball FBGA (260 user I/O)
- Optimized for 3.3V systems
 - Ultra low power operation
 - Typical Standby Current of 18 μ A at 25° C
 - 5V tolerant I/O pins with 3.3V core supply
 - Advanced 0.35 micron five layer metal EEPROM process
 - Fast Zero Power™ (FZP) CMOS design technology
 - 3.3V PCI electrical specification compatible outputs (no internal clamp diode on any input or I/O)
- Advanced system features
 - In-system programming
 - Input registers
 - Predictable timing model
 - Up to 23 clocks available per function block
 - Excellent pin retention during design changes
 - Full IEEE Standard 1149.1 boundary-scan (JTAG)
 - Four global clocks
 - Eight product term control terms per function block
- Fast ISP programming times
- Port Enable pin for additional I/O
- 2.7V to 3.6V supply voltage at industrial grade voltage range
- Programmable slew rate control per output
- Security bit prevents unauthorized access
- Refer to the CoolRunner™ XPLA3 family data sheet ([DS012](#)) for architecture description

Description

The CoolRunner™ XPLA3 XCR3512XL device is a 3.3V, 512 macrocell CPLD targeted at power sensitive designs that require leading edge programmable logic solutions. A total of 32 function blocks provide 12,000 usable gates. Pin-to-pin propagation delays are as fast as 7.0 ns with a maximum system frequency of 135 MHz.

TotalCMOS Design Technique for Fast Zero Power

CoolRunner XPLA3 CPLDs offer a TotalCMOS™ solution, both in process technology and design technique. This family employs a cascade of CMOS gates to implement its sum of products, instead of the traditional sense amp approach. This CMOS gate implementation allows Xilinx to offer CPLDs that are both high performance and low power, breaking the paradigm that to have low power, you must have low performance. Refer to [Figure 1](#) and [Table 1](#) showing the I_{CC} vs. Frequency of our XCR3512XL TotalCMOS CPLD (data taken with 32 resettable up/down, 16-bit counters at 3.3V, 25°C).

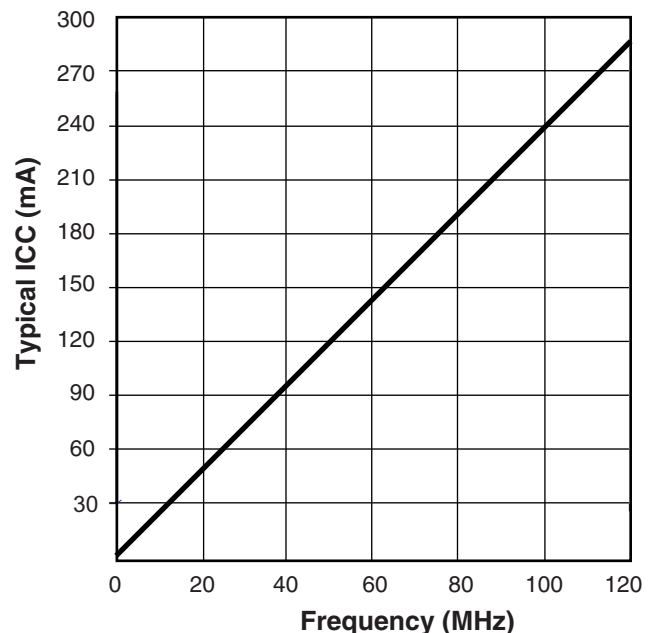

Figure 1: Typical I_{CC} vs. Frequency at $V_{CC} = 3.3V$, 25°C

Table 1: Typical I_{CC} vs. Frequency at $V_{CC} = 3.3V$, 25°C

Frequency (MHz)	0	1	10	20	40	60	80	100	120
Typical I_{CC} (mA)	0.018	2.57	25.5	50.8	100.3	147.9	193.5	237.8	281.6

DC Electrical Characteristics Over Recommended Operating Conditions⁽¹⁾

Symbol	Parameter	Test Conditions	Typical	Min.	Max.	Unit
$V_{OH}^{(2)}$	Output High voltage	$V_{CC} = 3.0V$ to $3.6V$, $I_{OH} = -8$ mA	-	2.4	-	V
		$V_{CC} = 2.7V$ to $3.0V$, $I_{OH} = -8$ mA	-	2.0	-	V
		$I_{OH} = -500$ μA	-	90% $V_{CC}^{(3)}$	-	V
V_{OL}	Output Low voltage	$I_{OL} = 8$ mA	-	-	0.4	V
I_{IL}	Input leakage current	$V_{IN} = GND$ or V_{CC} to $5.5V$	-	-10	10	μA
I_{IH}	I/O High-Z leakage current	$V_{IN} = GND$ or V_{CC} to $5.5V$	-	-10	10	μA
$I_{CCSB}^{(7)}$	Standby current	$V_{CC} = 3.6V$	32.5	-	100	μA
I_{CC}	Dynamic current ^(4,5)	$f = 1$ MHz	-	-	7	mA
		$f = 50$ MHz	-	-	175	mA
C_{IN}	Input pin capacitance ⁽⁶⁾	$f = 1$ MHz	-	-	8	pF
C_{CLK}	Clock input capacitance ⁽⁶⁾	$f = 1$ MHz	-	-	12	pF
$C_{I/O}$	I/O pin capacitance ⁽⁶⁾	$f = 1$ MHz	-	-	10	pF

Notes:

1. See CoolRunner XPLA3 family data sheet ([DS012](#)) for recommended operating conditions
2. See [Figure 2](#) for output drive characteristics of the CoolRunner XPLA3 family.
3. This parameter guaranteed by design and characterization, not by testing.
4. See [Table 1](#), [Figure 1](#) for typical values.
5. This parameter measured with a 16-bit, resettable up/down counter loaded into every function block, with all outputs disabled and unloaded. Inputs are tied to V_{CC} or ground. This parameter guaranteed by design and characterization, not testing.
6. Typical values, not tested.
7. Typical value at $70^{\circ} C$.

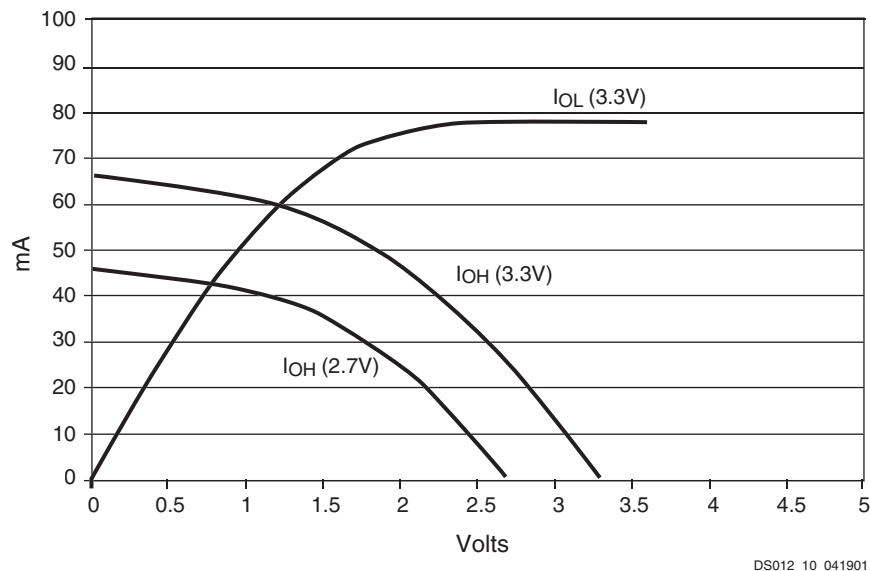

Figure 2: Typical I/V Curve for the CoolRunner XPLA3 Family, 25°C

AC Electrical Characteristics Over Recommended Operating Conditions^(1,2)

Symbol	Parameter	-7		-10		-12		Unit
		Min.	Max.	Min.	Max.	Min.	Max.	
T _{PD1}	Propagation delay time (single p-term)	-	7.0	-	9.0	-	10.8	ns
T _{PD2}	Propagation delay time (OR array) ⁽³⁾	-	7.5	-	10.0	-	12.0	ns
T _{CO}	Clock to output (global synchronous pin clock)	-	5.0	-	5.8	-	6.9	ns
T _{SUF}	Setup time (fast input register)	4.0	-	5.0	-	5.0	-	ns
T _{SU1} ⁽⁴⁾	Setup time (single p-term)	3.8	-	5.5	-	6.7	-	ns
T _{SU2}	Setup time (OR array)	4.3	-	6.5	-	7.9	-	ns
T _H ⁽⁴⁾	Hold time	0	-	0	-	0	-	ns
T _{WLH} ⁽⁴⁾	Global Clock pulse width (High or Low)	3.0	-	4.0	-	5.0	-	ns
T _{PLH} ⁽⁴⁾	P-term clock pulse width	4.5	-	6.0	-	7.5	-	ns
T _{APRPW}	Asynchronous preset/reset pulse width (High or Low)	4.5	-	6.0	-	7.5	-	ns
T _R ⁽⁴⁾	Input rise time	-	20	-	20	-	20	ns
T _L ⁽⁴⁾	Input fall time	-	20	-	20	-	20	ns
f _{SYSTEM} ⁽⁴⁾	Maximum system frequency	-	135	-	97	-	77	MHz
T _{CONFIG} ⁽⁴⁾	Configuration time ⁽⁵⁾	-	200	-	200	-	200	μs
T _{INIT} ⁽⁴⁾	ISP initialization time	-	200	-	200	-	200	μs
T _{POE} ⁽⁴⁾	P-term OE to output enabled	-	9.0	-	11.0	-	13.0	ns
T _{POD} ⁽⁴⁾	P-term OE to output disabled ⁽⁶⁾	-	9.0	-	11.0	-	13.0	ns
T _{PCO} ⁽⁴⁾	P-term clock to output	-	8.5	-	10.3	-	12.4	ns
T _{PAO} ⁽⁴⁾	P-term set/reset to output valid	-	9.0	-	11.0	-	13.0	ns

Notes:

1. Specifications measured with one output switching.
2. See the CoolRunner XPLA3 family data sheet ([DS012](#)) for recommended operating conditions.
3. See [Figure 4](#) for derating.
4. These parameters guaranteed by design and/or characterization, not testing.
5. Typical current draw during configuration is 17 mA at 3.6V.
6. Output C_L = 5 pF.

Internal Timing Parameters^(1,2)

Symbol	Parameter	-7		-10		-12		Unit
		Min.	Max.	Min.	Max.	Min.	Max.	
Buffer Delays								
T _{IN}	Input buffer delay	-	2.5	-	3.3	-	4.0	ns
T _{FIN}	Fast input buffer delay	-	4.7	-	4.3	-	4.3	ns
T _{GCK}	Global clock buffer delay	-	1.5	-	1.3	-	1.5	ns
T _{OUT}	Output buffer delay	-	2.5	-	3.2	-	3.8	ns
T _{EN}	Output buffer enable/disable delay	-	4.5	-	5.2	-	6.0	ns
Internal Register and Combinatorial Delays								
T _{LDI}	Latch transparent delay	-	1.3	-	1.6	-	2.0	ns
T _{SUI}	Register setup time	0.8	-	1.0	-	1.2	-	ns
T _{HI}	Register hold time	0.3	-	0.5	-	0.7	-	ns
T _{ECSU}	Register clock enable setup time	2.0	-	2.5	-	3.0	-	ns
T _{ECHO}	Register clock enable hold time	3.0	-	4.5	-	5.5	-	ns
T _{COI}	Register clock to output delay	-	1.0	-	1.3	-	1.6	ns
T _{AOI}	Register async. S/R to output delay	-	2.0	-	2.0	-	2.2	ns
T _{RAI}	Register async. recovery	-	5.0	-	7.0	-	8.0	ns
T _{PTCK}	Product term clock delay	-	2.5	-	2.5	-	3.0	ns
T _{LOGI1}	Internal logic delay (single p-term)	-	2.0	-	2.5	-	3.0	ns
T _{LOGI2}	Internal logic delay (PLA OR term)	-	2.5	-	3.5	-	4.2	ns
Feedback Delays								
T _F	ZIA delay	-	3.1	-	4.5	-	6.0	ns
Time Adders								
T _{LOGI3}	Fold-back NAND delay	-	2.0	-	2.5	-	3.0	ns
T _{UDA}	Universal delay	-	3.5	-	4.0	-	4.0	ns
T _{SLEW}	Slew rate limited delay	-	5.0	-	5.0	-	6.0	ns

Notes:

1. These parameters guaranteed by design and/or characterization, not testing.
2. See the CoolRunner XPLA3 family data sheet ([DS012](#)) for timing model.

Switching Characteristics

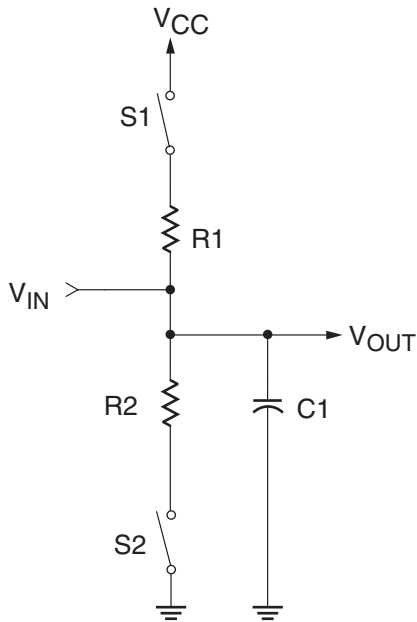

Component	Values
R1	390Ω
R2	390Ω
C1	35 pF

Measurement	S1	S2
T _{POE} (High)	Open	Closed
T _{POE} (Low)	Closed	Open
T _P	Closed	Closed

Note: For T_{POD}, C1 = 5 pF. Delay measured at output level of V_{OL} + 300 mV, V_{OH} - 300 mV.

DS023_03_102401

Figure 3: AC Load Circuit

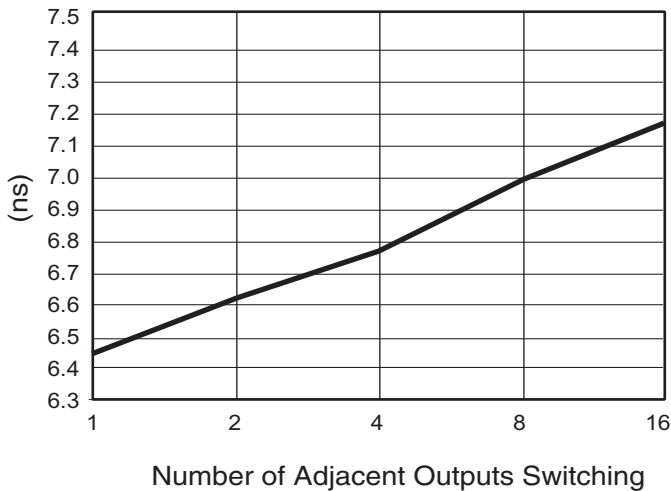

DS081_04_120902

Figure 4: Derating Curve for T_{PD2}

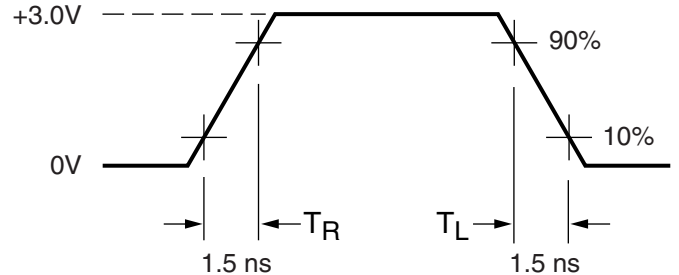

Measurements:

All circuit delays are measured at the +1.5V level of inputs and outputs, unless otherwise specified.

DS017_05_042800

Figure 5: Voltage Waveform

Pin Descriptions

Table 2: XCR3512XL User I/O Pins

	PQ208	FT256	FG324
Total User I/O Pins	180	212	260

Table 3: XCR3512XL I/O Pins

Function Block	Macrocell	PQ208	FT256	FG324
1	1	208	C14	C21
1	2	-	D13	C20
1	3	207	-	B22
1	4	206	A15	B21
1	5	-	-	-
1	6	-	-	-
1	7	-	-	-
1	8	-	-	-
1	9	-	-	-
1	10	-	-	-
1	11	-	-	-
1	12	-	-	-
1	13	-	-	A22
1	14	205	B15	A21
1	15	-	B14	B20
1	16	204	C13	C19
2	1	1	E12	D20
2	2	-	-	C22
2	3	2	A16	D21
2	4	-	C15	D22
2	5	-	-	-
2	6	-	-	-
2	7	-	-	-
2	8	-	-	-
2	9	-	-	-
2	10	-	-	-
2	11	-	-	-
2	12	-	-	-
2	13	3	B16	E20

Table 3: XCR3512XL I/O Pins (Continued)

Function Block	Macrocell	PQ208	FT256	FG324
2	14	4	D14	F19
2	15	-	-	E21
2	16	6	D15	E22
3	1	203	A14	B19
3	2	-	E11	A20
3	3	202	-	C18
3	4	201	A13	B18
3	5	-	-	-
3	6	-	-	-
3	7	-	-	-
3	8	-	-	-
3	9	-	-	-
3	10	-	-	-
3	11	-	-	-
3	12	-	-	-
3	13	-	D12	A19
3	14	-	-	D17
3	15	199	B13	A18
3	16	198	C12	C17
4	1	7	E13	F20
4	2	-	-	F21
4	3	8	C16	F22
4	4	9	F12	G19
4	5	-	-	-
4	6	-	-	-
4	7	-	-	-
4	8	-	-	-
4	9	-	-	-
4	10	-	-	-
4	11	-	-	-
4	12	-	-	-
4	13	-	-	G20
4	14	10	D16	G21
4	15	-	E14	G22
4	16	11	E15	H20

Table 3: XCR3512XL I/O Pins (Continued)

Function Block	Macrocell	PQ208	FT256	FG324
5	1	197	A12	B17
5	2	-	-	A17
5	3	196	D11	D16
5	4	-	-	C16
5	5	-	-	-
5	6	-	-	-
5	7	-	-	-
5	8	-	-	-
5	9	-	-	-
5	10	-	-	-
5	11	-	-	-
5	12	-	-	-
5	13	195	A11	B16
5	14	-	E10	A16
5	15	194	B12	C15
5	16	193	C11	B15
6	1	12	F13	H21
6	2	-	-	H22
6	3	13	E16	J19
6	4	-	-	J20
6	5	-	-	-
6	6	-	-	-
6	7	-	-	-
6	8	-	-	-
6	9	-	-	-
6	10	-	-	-
6	11	-	-	-
6	12	-	-	-
6	13	15	F15	J21
6	14	16	G12	J22
6	15	-	F14	K19
6	16	17	G15	K20
7	1	192	B11	A15
7	2	-	D10	D14
7	3	190	A10	C14

Table 3: XCR3512XL I/O Pins (Continued)

Function Block	Macrocell	PQ208	FT256	FG324
7	4	189 ⁽¹⁾	C10 ⁽¹⁾	B14 ⁽¹⁾
7	5	-	-	-
7	6	-	-	-
7	7	-	-	-
7	8	-	-	-
7	9	-	-	-
7	10	-	-	-
7	11	-	-	-
7	12	-	-	-
7	13	188	-	A14
7	14	-	-	D13
7	15	-	A9	C13
7	16	187	D9	B13
8	1	18	G13	K21
8	2	-	-	K22
8	3	19	F16	L19
8	4	-	-	L20
8	5	-	-	-
8	6	-	-	-
8	7	-	-	-
8	8	-	-	-
8	9	-	-	-
8	10	-	-	-
8	11	-	-	-
8	12	-	-	-
8	13	20	G14	L21
8	14	21	G16	L22
8	15	22	H13	M21
8	16	24	H12	M20
9	1	51	P16	AA21
9	2	-	N14	AB22
9	3	49	R16	AA22
9	4	-	-	Y20
9	5	-	-	-
9	6	-	-	-

Table 3: XCR3512XL I/O Pins (Continued)

Function Block	Macrocell	PQ208	FT256	FG324
9	7	-	-	-
9	8	-	-	-
9	9	-	-	-
9	10	-	-	-
9	11	-	-	-
9	12	-	-	-
9	13	48	M13	Y21
9	14	47	P15	W20
9	15	46	L12	W21
9	16	45	N16	Y22
10	1	52	N13	AB21
10	2	53	R15	Y19
10	3	54	M12	AA20
10	4	-	-	AB20
10	5	-	-	-
10	6	-	-	-
10	7	-	-	-
10	8	-	-	-
10	9	-	-	-
10	10	-	-	-
10	11	-	-	-
10	12	-	-	-
10	13	55	T16	Y18
10	14	56	P14	AA19
10	15	-	T15	AB19
10	16	57	P13	W17
11	1	44	M14	W22
11	2	43	M16	V20
11	3	42	L13	V21
11	4	-	N15	U19
11	5	-	-	-
11	6	-	-	-
11	7	-	-	-
11	8	-	-	-
11	9	-	-	-

Table 3: XCR3512XL I/O Pins (Continued)

Function Block	Macrocell	PQ208	FT256	FG324
11	10	-	-	-
11	11	-	-	-
11	12	-	-	-
11	13	-	-	V22
11	14	40	M15	U20
11	15	39	L16	U21
11	16	38	K12	U22
12	1	58	R14	Y17
12	2	-	N12	AA18
12	3	59	T14	AB18
12	4	-	-	AA17
12	5	-	-	-
12	6	-	-	-
12	7	-	-	-
12	8	-	-	-
12	9	-	-	-
12	10	-	-	-
12	11	-	-	-
12	12	-	-	-
12	13	60	M11	AB17
12	14	-	R13	W16
12	15	61	P12	Y16
12	16	62	T13	AA16
13	1	37	L15	T19
13	2	-	-	T20
13	3	36	K13	T21
13	4	35	K16	T22
13	5	-	-	-
13	6	-	-	-
13	7	-	-	-
13	8	-	-	-
13	9	-	-	-
13	10	-	-	-
13	11	-	-	-
13	12	-	-	-

Table 3: XCR3512XL I/O Pins (Continued)

Function Block	Macrocell	PQ208	FT256	FG324
13	13	-	K14	R20
13	14	34	K15	R21
13	15	33	L14	R22
13	16	31	J16	P19
14	1	64	N11	AB16
14	2	-	R12	Y15
14	3	65	T12	AA15
14	4	66	R11	AB15
14	5	-	-	-
14	6	-	-	-
14	7	-	-	-
14	8	-	-	-
14	9	-	-	-
14	10	-	-	-
14	11	-	-	-
14	12	-	-	-
14	13	67	M10	W14
14	14	68	P11	Y14
14	15	-	-	AA14
14	16	69	N10	AB14
15	1	30 ⁽¹⁾	J13 ⁽¹⁾	P20 ⁽¹⁾
15	2	29	J15	P21
15	3	28	J14	P22
15	4	-	-	N19
15	5	-	-	-
15	6	-	-	-
15	7	-	-	-
15	8	-	-	-
15	9	-	-	-
15	10	-	-	-
15	11	-	-	-
15	12	-	-	-
15	13	27	H16	N21
15	14	-	-	N22
15	15	26	H14	M22

Table 3: XCR3512XL I/O Pins (Continued)

Function Block	Macrocell	PQ208	FT256	FG324
15	16	25	H15	M19
16	1	70	T11	W13
16	2	71	R10	Y13
16	3	73	P10	AA13
16	4	-	T10	AB13
16	5	-	-	-
16	6	-	-	-
16	7	-	-	-
16	8	-	-	-
16	9	-	-	-
16	10	-	-	-
16	11	-	-	-
16	12	-	-	-
16	13	-	-	W12
16	14	76	N9	AA12
16	15	77	R9	AB12
16	16	78	P9	Y11
17	1	157	B1	C3
17	2	-	B2	A2
17	3	158	C3	B3
17	4	-	-	C4
17	5	-	-	-
17	6	-	-	-
17	7	-	-	-
17	8	-	-	-
17	9	-	-	-
17	10	-	-	-
17	11	-	-	-
17	12	-	-	-
17	13	159	D4	B4
17	14	-	A2	C5
17	15	160	A1	B5
17	16	161	B3	A3
18	1	156	C1	D3
18	2	155	D3	B2

Table 3: XCR3512XL I/O Pins (Continued)

Function Block	Macrocell	PQ208	FT256	FG324
18	3	154	C2	B1
18	4	153	F5	C2
18	5	-	-	-
18	6	-	-	-
18	7	-	-	-
18	8	-	-	-
18	9	-	-	-
18	10	-	-	-
18	11	-	-	-
18	12	-	-	-
18	13	-	-	C1
18	14	151	D1	E3
18	15	-	-	D2
18	16	150	E4	D1
19	1	162	C4	A4
19	2	-	-	D6
19	3	163	A3	A5
19	4	-	D5	C6
19	5	-	-	-
19	6	-	-	-
19	7	-	-	-
19	8	-	-	-
19	9	-	-	-
19	10	-	-	-
19	11	-	-	-
19	12	-	-	-
19	13	164	B4	B6
19	14	-	E6	A6
19	15	166	A4	D7
19	16	167	C5	C7
20	1	149	D2	F4
20	2	148	E3	F3
20	3	-	-	E2
20	4	147	E1	E1
20	5	-	-	-

Table 3: XCR3512XL I/O Pins (Continued)

Function Block	Macrocell	PQ208	FT256	FG324
20	6	-	-	-
20	7	-	-	-
20	8	-	-	-
20	9	-	-	-
20	10	-	-	-
20	11	-	-	-
20	12	-	-	-
20	13	-	-	F2
20	14	146	F4	F1
20	15	145	F1	G4
20	16	144	G5	G3
21	1	168	B5	B7
21	2	-	D6	A7
21	3	169	A5	C8
21	4	-	-	B8
21	5	-	-	-
21	6	-	-	-
21	7	-	-	-
21	8	-	-	-
21	9	-	-	-
21	10	-	-	-
21	11	-	-	-
21	12	-	-	-
21	13	170	C6	A8
21	14	171	B6	D9
21	15	-	E7	C9
21	16	172	A6	B9
22	1	142	E2	G2
22	2	141	F3	G1
22	3	-	-	H3
22	4	140	F2	H2
22	5	-	-	-
22	6	-	-	-
22	7	-	-	-
22	8	-	-	-

Table 3: XCR3512XL I/O Pins (Continued)

Function Block	Macrocell	PQ208	FT256	FG324
22	9	-	-	-
22	10	-	-	-
22	11	-	-	-
22	12	-	-	-
22	13	-	-	H1
22	14	139	G4	J4
22	15	-	G1	J3
22	16	138	G3	J2
23	1	173	D7	A9
23	2	-	B7	D10
23	3	175	C7	C10
23	4	-	C8	B10
23	5	-	-	-
23	6	-	-	-
23	7	-	-	-
23	8	-	-	-
23	9	-	-	-
23	10	-	-	-
23	11	-	-	-
23	12	-	-	-
23	13	-	-	A10
23	14	176 ⁽¹⁾	A7 ⁽¹⁾	D11 ⁽¹⁾
23	15	177	D8	C11
23	16	178	B8	B11
24	1	137	H1	J1
24	2	136	H4	K4
24	3	135	G2	K3
24	4	-	H3	K2
24	5	-	-	-
24	6	-	-	-
24	7	-	-	-
24	8	-	-	-
24	9	-	-	-
24	10	-	-	-
24	11	-	-	-

Table 3: XCR3512XL I/O Pins (Continued)

Function Block	Macrocell	PQ208	FT256	FG324
24	12	-	-	-
24	13	133	J1	K1
24	14	-	-	L1
24	15	-	-	L4
24	16	132	J3	L3
25	1	105	P2	AA1
25	2	106	P3	Y3
25	3	-	-	Y2
25	4	108	T1	W3
25	5	-	-	-
25	6	-	-	-
25	7	-	-	-
25	8	-	-	-
25	9	-	-	-
25	10	-	-	-
25	11	-	-	-
25	12	-	-	-
25	13	-	-	Y1
25	14	109	N3	W2
25	15	110	R1	W1
25	16	111	M4	V3
26	1	104	M5	AB1
26	2	-	N4	AA2
26	3	103	R2	AB2
26	4	-	T2	AA3
26	5	-	-	-
26	6	-	-	-
26	7	-	-	-
26	8	-	-	-
26	9	-	-	-
26	10	-	-	-
26	11	-	-	-
26	12	-	-	-
26	13	102	P4	Y4
26	14	-	-	AB3

Table 3: XCR3512XL I/O Pins (Continued)

Function Block	Macrocell	PQ208	FT256	FG324
26	15	101	R3	AA4
26	16	100	N5	Y5
27	1	112	P1	U4
27	2	-	-	V2
27	3	113	L5	V1
27	4	114	N2	U3
27	5	-	-	-
27	6	-	-	-
27	7	-	-	-
27	8	-	-	-
27	9	-	-	-
27	10	-	-	-
27	11	-	-	-
27	12	-	-	-
27	13	-	-	U2
27	14	115	M3	U1
27	15	117	L4	T3
27	16	118	M2	T2
28	1	99	T3	AA5
28	2	98	M6	AB4
28	3	-	R4	W6
28	4	97	P5	AB5
28	5	-	-	-
28	6	-	-	-
28	7	-	-	-
28	8	-	-	-
28	9	-	-	-
28	10	-	-	-
28	11	-	-	-
28	12	-	-	-
28	13	-	-	Y6
28	14	96	T4	AA6
28	15	95	N6	AB6
28	16	93	R5	W7
29	1	119	L2	T1

Table 3: XCR3512XL I/O Pins (Continued)

Function Block	Macrocell	PQ208	FT256	FG324
29	2	-	-	R3
29	3	120	M1	R2
29	4	121	K5	R1
29	5	-	-	-
29	6	-	-	-
29	7	-	-	-
29	8	-	-	-
29	9	-	-	-
29	10	-	-	-
29	11	-	-	-
29	12	-	-	-
29	13	122	L3	P4
29	14	123	K4	P3
29	15	-	-	P2
29	16	124	L1	P1
30	1	92	T6	Y7
30	2	-	T5	AA7
30	3	91	M7	AB7
30	4	-	-	Y8
30	5	-	-	-
30	6	-	-	-
30	7	-	-	-
30	8	-	-	-
30	9	-	-	-
30	10	-	-	-
30	11	-	-	-
30	12	-	-	-
30	13	90	R6	AA8
30	14	89	N7	AB8
30	15	88	T7	W9
30	16	87	P6	Y9
31	1	126	K2	N4
31	2	-	K3	N3
31	3	127 ⁽¹⁾	K1 ⁽¹⁾	N2 ⁽¹⁾
31	4	128	J4	N1

Table 3: XCR3512XL I/O Pins (Continued)

Function Block	Macrocell	PQ208	FT256	FG324
31	5	-	-	-
31	6	-	-	-
31	7	-	-	-
31	8	-	-	-
31	9	-	-	-
31	10	-	-	-
31	11	-	-	-
31	12	-	-	-
31	13	-	-	M4
31	14	129	J2	M3
31	15	130	J5	M2
31	16	131	H2	L2
32	1	86	R7	AA9
32	2	-	P7	AB9
32	3	84	T8	W10
32	4	-	N8	Y10
32	5	-	-	-
32	6	-	-	-
32	7	-	-	-
32	8	-	-	-
32	9	-	-	-
32	10	-	-	-
32	11	-	-	-
32	12	-	-	-
32	13	-	-	AA10
32	14	81	R8	AB11
32	15	80	P8	W11
32	16	79	T9	AA11

Notes:

- JTAG pins.

Table 4: XCR3512XL Global, JTAG, Port Enable, Power, and No Connect Pins

Pin Type	PQ208	FT256	FG324
IN0 / CLK0	181	B9	C12
IN1 / CLK1	182	A8	B12
IN2 / CLK2	183	C9	D12
IN3 / CLK3	184	B10	A12
TCK	30	J13	P20
TDI	176	A7	D11
TDO	189	C10	B14
TMS	127	K1	N2
PORT_EN	116 ⁽¹⁾	N1 ⁽¹⁾	T4 ⁽¹⁾
Vcc	5, 23, 41, 63, 74, 83, 85, 107, 125, 143, 165, 179, 186, 191	E8, E9, F7, F8, F9, F10, G6, G11, H5, H6, H11, J6, J11, J12, K6, K11, L7, L8, L9, L10, M8, M9	A11, A13, D8, D15, H4, H19, J10, J11, J12, J13, K9, K14, L9, L14, M1, M9, M14, N9, N14, N20, P10, P11, P12, P13, R4, R19, W8, W15, Y12, AB10
GND	14, 32, 50, 72, 75, 82, 94, 134, 152, 174, 180, 185, 200	E5, F6, F11, G7, G8, G9, G10, H7, H8, H9, H10, J7, J8, J9, J10, K7, K8, K9, K10, L6, L11	D4, D5, D18, D19, E4, E19, J9, J14, K10, K11, K12, K13, L10, L11, L12, L13, M10, M11, M12, M13, N10, N11, N12, N13, P9, P14, V4, V19, W4, W5, W18, W19
No Connects	-	-	A1

Notes:

- Port Enable is brought High to enable JTAG pins when JTAG pins are used as I/O. See family data sheet ([DS012](#)) for full explanation.

Device Part Marking and Ordering Combination Information

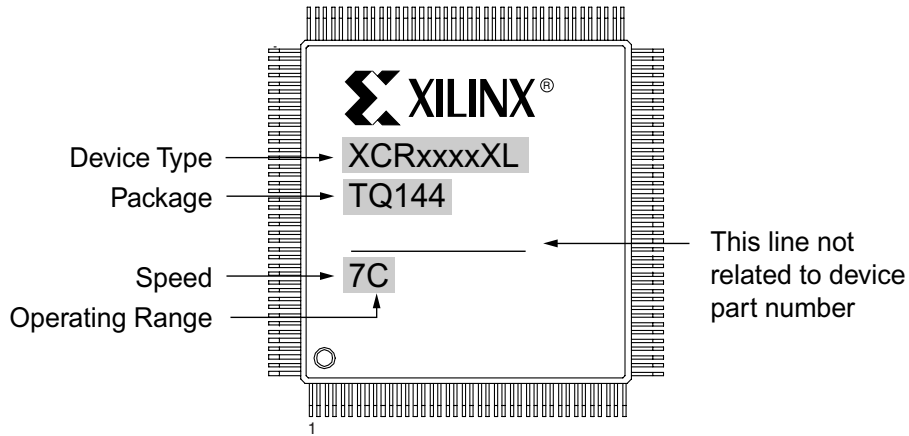

Sample package with part marking.

Device Ordering and Part Marking Number	Speed (pin-to-pin delay)	Pkg. Symbol	No. of Pins	Package Type	Operating Range ⁽¹⁾
XCR3512XL-7PQ208C	7.5 ns	PQ208	208-pin	Plastic Quad Flat Pack (PQFP)	C
XCR3512XL-7PQG208C	7.5 ns	PQG208	208-pin	Plastic Quad Flat Pack (PQFP); Pb-Free	C
XCR3512XL-7FT256C	7.5 ns	FT256	256-ball	Fine-Pitch BGA (FT)	C
XCR3512XL-7FG324C	7.5 ns	FG324	324-ball	Fineline BGA Package (FG)	C
XCR3512XL-10PQ208C	10 ns	PQ208	208-pin	Plastic Quad Flat Pack (PQFP)	C
XCR3512XL-10PQG208C	10 ns	PQG208	208-pin	Plastic Quad Flat Pack (PQFP); Pb-Free	C
XCR3512XL-10FT256C	10 ns	FT256	256-ball	Fine-Pitch BGA (FT)	C
XCR3512XL-10FG324C	10 ns	FG324	324-ball	Fineline BGA Package (FG)	C
XCR3512XL-10PQ208I	10 ns	PQ208	208-pin	Plastic Quad Flat Pack (PQFP)	I
XCR3512XL-10PQG208I	10 ns	PQG208	208-pin	Plastic Quad Flat Pack (PQFP); Pb-Free	I
XCR3512XL-10FT256I	10 ns	FT256	256-ball	Fine-Pitch BGA (FT)	I
XCR3512XL-10FG324I	10 ns	FG324	324-ball	Fineline BGA Package (FG)	I
XCR3512XL-12PQ208C	12 ns	PQ208	208-pin	Plastic Quad Flat Pack (PQFP)	C
XCR3512XL-12PQG208C	12 ns	PQG208	208-pin	Plastic Quad Flat Pack (PQFP); Pb-Free	C
XCR3512XL-12FT256C	12 ns	FT256	256-ball	Fine-Pitch BGA (FT)	C
XCR3512XL-12FG324C	12 ns	FG324	324-ball	Fineline BGA Package (FG)	C
XCR3512XL-12PQ208I	12 ns	PQ208	208-pin	Plastic Quad Flat Pack (PQFP)	I
XCR3512XL-12PQG208I	12 ns	PQG208	208-pin	Plastic Quad Flat Pack (PQFP); Pb-Free	I
XCR3512XL-12FT256I	12 ns	FT256	256-ball	Fine-Pitch BGA (FT)	I
XCR3512XL-12FG324I	12 ns	FG324	324-ball	Fineline BGA Package (FG)	I

Notes:

1. C = Commercial: $T_A = 0^\circ$ to $+70^\circ\text{C}$; I = Industrial: $T_A = -40^\circ$ to $+85^\circ\text{C}$

Warranty Disclaimer

THESE PRODUCTS ARE SUBJECT TO THE TERMS OF THE XILINX LIMITED WARRANTY WHICH CAN BE VIEWED AT <http://www.xilinx.com/warranty.htm>. THIS LIMITED WARRANTY DOES NOT EXTEND TO ANY USE OF THE PRODUCTS IN AN APPLICATION OR ENVIRONMENT THAT IS NOT WITHIN THE SPECIFICATIONS STATED ON THE THEN-CURRENT XILINX DATA SHEET FOR THE PRODUCTS. PRODUCTS ARE NOT DESIGNED TO BE FAIL-SAFE AND ARE NOT WARRANTED FOR USE IN APPLICATIONS THAT POSE A RISK OF PHYSICAL HARM OR LOSS OF LIFE. USE OF PRODUCTS IN SUCH APPLICATIONS IS FULLY AT THE RISK OF CUSTOMER SUBJECT TO APPLICABLE LAWS AND REGULATIONS.

Additional Information

[CoolRunner XPLA3 Data Sheets and Application Notes](#) [Device Package User Guide](#)

[Device Packages](#)

Revision History

The following table shows the revision history for this document

Date	Version	Revision
04/11/01	1.0	Initial Xilinx release.
04/19/01	1.1	Updated Typical I/V curve, Figure 2 : added voltage levels.
09/04/01	1.2	Updated AC Electrical: added T _{INIT} spec.; Internal Timing Parameters; added -12 industrial temperature.
01/08/02	1.3	Updated T _{INIT} spec and T _{CONFIG} spec. Added single p-term setup time (T _{SU1}) to AC Table, renamed T _{SU} to T _{SU2} for setup time through the OR array. Updated T _{HI} spec to correct a typo. Updated AC Load Circuit diagram to more closely resemble true test conditions, added note for T _{POD} delay measurement.
01/06/03	1.4	Updated all AC and DC parameters based on product characterization. Released to Preliminary. Updated T _{PCO} (added T _{PTCK}). Updated Ordering Information format.
07/15/03	1.5	Updated test conditions for I _{IL} and I _{IH} .
09/23/03	1.6	Updated Package Device Marking Pin 1 orientation. Removed Preliminary.
02/13/04	1.7	Add solder temperature specification. Add links to data sheets, application notes, and packages.
01/05/05	1.8	Fixed broken links.
04/08/05	1.9	Added I _{CCSB} Typical and T _{APRPW} specifications. Removed T _{SOL} specification.
03/31/06	2.0	Added Warranty Disclaimer; Added Pb-Free package ordering information.

OUR CERTIFICATE

DiGi provide top-quality products and perfect service for customer worldwide through standardization, technological innovation and continuous improvement. DiGi through third-party certification, we stricly control the quality of products and services. Welcome your RFQ to

Email: Info@DiGi-Electronics.com



Tel: +00 852-30501935

RFQ Email: Info@DiGi-Electronics.com

DiGi is a global authorized distributor of electronic components.