

PI3EQX7502MZDE+CWX Datasheet

www.digi-electronics.com

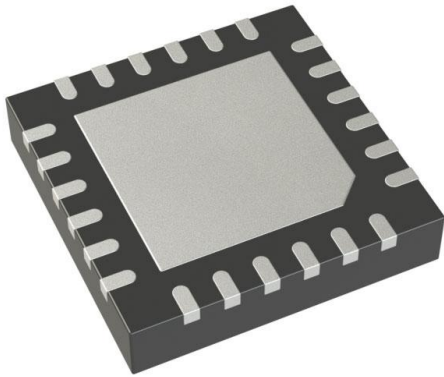

<https://www.DiGi-Electronics.com>

DiGi Electronics Part Number	PI3EQX7502MZDE+CWX-DG
Manufacturer	Diodes Incorporated
Manufacturer Product Number	PI3EQX7502MZDE+CWX
Description	IC REDRIVER USB 3.0 1CH 24TQFN
Detailed Description	Buffer, ReDriver 1 Channel 5Gbps 24-TQFN (4x4)



Tel: +00 852-30501935

RFQ Email: Info@DiGi-Electronics.com

DiGi is a global authorized distributor of electronic components.

Purchase and inquiry

Manufacturer Product Number:

PI3EQX7502MZDE+CWX

Series:

ReDriver™

Type:

Buffer, ReDriver

Input:

CML

Data Rate (Max):

5Gbps

Delay Time:

305ps

Voltage - Supply:

3V ~ 3.6V

Operating Temperature:

-

Package / Case:

24-VFQFN Exposed Pad

Base Product Number:

PI3EQX7502

Manufacturer:

Diodes Incorporated

Product Status:

Active

Applications:

USB 3.0

Output:

CML

Number of Channels:

1

Signal Conditioning:

Input Equalization, Output De-Emphasis

Current - Supply:

125mA

Mounting Type:

Surface Mount

Supplier Device Package:

24-TQFN (4x4)

Environmental & Export classification

RoHS Status:

ROHS3 Compliant

ECCN:

EAR99

REACH Status:

REACH Unaffected

HTSUS:

8542.39.0001

PI3EQX7502M

5.0Gbps, 1-port, USB3.0 ReDriver™

Pericom Semiconductor's PI3EQX7502M is a low power, high performance 5.0 Gbps signal ReDriver™ designed specifically for the USB 3.0 protocol. The device provides programmable equalization, De-Emphasis, and input threshold controls to optimize performance over a variety of physical mediums by reducing Inter-Symbol Interference. PI3EQX7502M supports two 100Ω Differential CML data I/O's between the Protocol ASIC to a switch fabric, over cable, or to extend the signals across other distant data pathways on the user's platform.

The integrated equalization circuitry provides flexibility with signal integrity of the signal before the ReDriver. A low-level input signal detection and output squelch function is provided for each channel. Each channel operates fully independently. When the channels are enabled $EN_x\# = 0$ and operating, that channels' input signal level ($onx\{+/-\}$) determines whether the output is active. If the input signal level of the channel falls below the active threshold level (V_{th-}) then the outputs are driven to the common mode voltage. In addition to signal conditioning, when $EN_x\# = 1$, the device enters a low power standby mode.

The PI3EQX7502M also includes a fully programmable receiver detect function. When the RXD-EN pin is pulled high, automatic receiver detection will be active. The receiver detection loop will be active again if the corresponding channel's signal detector is idle for longer than 7.3mS. The channel will then move to Unplug Mode if load not detected, or it will return to Low Power Mode (Slumber Mode) due to inactivity.

Block Diagram

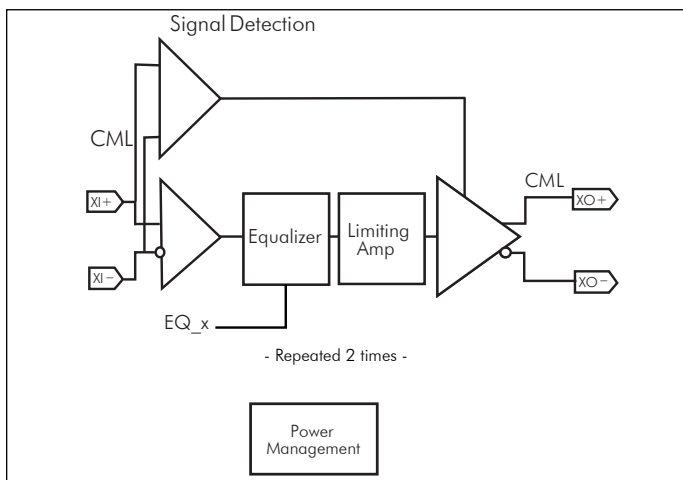

Features

- USB 3.0 compatible
- Full Compliancy to USB3.0 Super Speed Standard
- Two 5.0Gbps differential signal pairs
- Adjustable Receiver Equalization
- 100Ω Differential CML I/O's
- Pin Configured Output Emphasis Control
- Input signal level detect and squelch for each channel
- Automatic Receiver Detect with digital enable/disable
- Low Power : ~330mW
- Auto "Slumber" mode for adaptive power management
- Stand-by Mode – Power Down State
- Industrial Temp Support (-40°C to 85°C)
- Single Supply Voltage: 3.3V
- Packaging: 24-Pin TQFN (4x4mm)

Figure 1

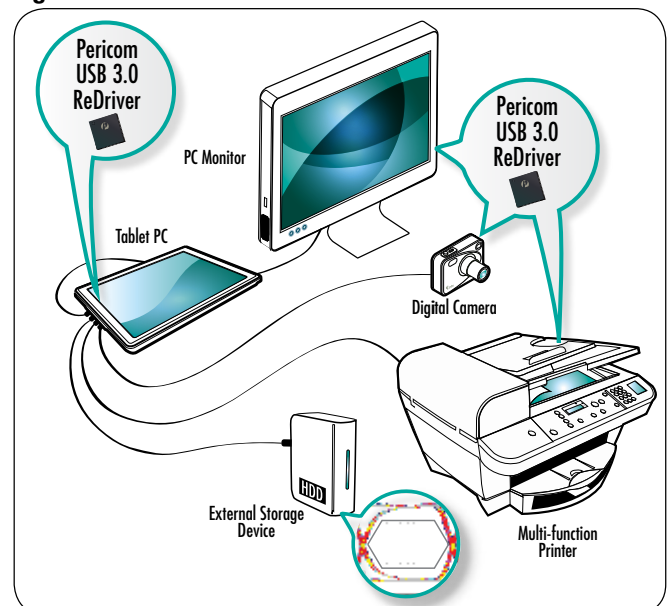

OUR CERTIFICATE

DiGi provide top-quality products and perfect service for customer worldwide through standardization, technological innovation and continuous improvement. DiGi through third-party certification, we stricly control the quality of products and services. Welcome your RFQ to

Email: Info@DiGi-Electronics.com



Tel: +00 852-30501935

RFQ Email: Info@DiGi-Electronics.com

DiGi is a global authorized distributor of electronic components.