

# UDZ9V1BQ-13 Datasheet

[www.digi-electronics.com](http://www.digi-electronics.com)

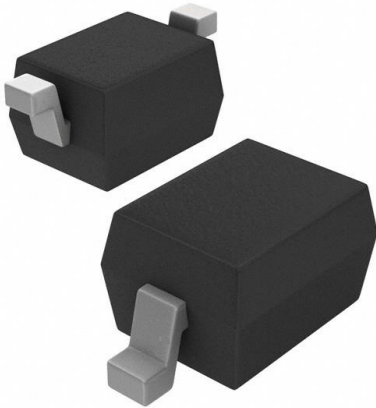

<https://www.DiGi-Electronics.com>

|                              |                                     |
|------------------------------|-------------------------------------|
| DiGi Electronics Part Number | UDZ9V1BQ-13-DG                      |
| Manufacturer                 | <a href="#">Diodes Incorporated</a> |
| Manufacturer Product Number  | UDZ9V1BQ-13                         |
| Description                  | DIODE ZENER SOD323                  |
| Detailed Description         | Zener Diode                         |

This model UDZ9V1BQ-13 is available at DiGi Electronics.

DiGi Electronics offers a global database of semiconductor and electronic component datasheets.

We welcome your inquiries regarding pricing, lead time, or other product-related questions.

 [Request a Quote](#)

 [Datasheet Search](#)



Tel: +00 852-30501935

RFQ Email: [Info@DiGi-Electronics.com](mailto:Info@DiGi-Electronics.com)

DiGi is a global authorized distributor of electronic components.

## Purchase and inquiry

Manufacturer Product Number:

UDZ9V1BQ-13

Series:

-

Tolerance:

-

Base Product Number:

UDZ9V1

Manufacturer:

Diodes Incorporated

Product Status:

Active

Operating Temperature:

-

## Environmental & Export classification

RoHS Status:

ROHS3 Compliant

REACH Status:

REACH Unaffected

HTSUS:

8541.10.0050

Moisture Sensitivity Level (MSL):

1 (Unlimited)

ECCN:

EAR99



UDZ9V1BQ

SURFACE MOUNT PRECISION ZENER DIODE

## Features

- Small, Surface Mount Package
- Ideally Suited for Automated Assembly Processes
- Very Sharp Breakdown Characteristics
- Very Tight Tolerance on Zener Breakdown Voltage
- **Totally Lead-Free & Fully RoHS Compliant (Notes 1 & 2)**
- **Halogen and Antimony Free. "Green" Device (Note 3)**
- **The UDZ9V1BQ is suitable for automotive applications requiring specific change control and is AEC-Q101 qualified, is PPAP capable, and is manufactured in IATF16949:2016 certified facilities.**

## Mechanical Data

- Case: SOD323
- Case Material: UL Flammability Classification Rating 94V-0
- Moisture Sensitivity: Level 1 per J-STD-020
- Terminal Connections: Cathode Band
- Terminals: Finish – Matte Tin Annealed over Alloy 42
- Leadframe: Solderable per MIL-STD-202, Method 208 **(E3)**
- Weight: 0.004 grams (Approximate)



Top View

## Ordering Information (Note 4)

| Part Number | Compliance | Case   | Shipping           |
|-------------|------------|--------|--------------------|
| UDZ9V1BQ-7  | Automotive | SOD323 | 3,000/Tape & Reel  |
| UDZ9V1BQ-13 | Automotive | SOD323 | 10,000/Tape & Reel |

- Notes:
1. No purposely added lead. Fully EU Directive 2002/95/EC (RoHS), 2011/65/EU (RoHS 2) & 2015/863/EU (RoHS 3) compliant.
  2. See <https://www.diodes.com/quality/lead-free/> for more information about Diodes Incorporated's definitions of Halogen- and Antimony-free, "Green" and Lead-free.
  3. Halogen- and Antimony-free "Green" products are defined as those which contain <900ppm bromine, <900ppm chlorine (<1500ppm total Br + Cl) and <1000ppm antimony compounds.
  4. For packaging details, go to our website at <https://www.diodes.com/design/support/packaging/diodes-packaging/>.

## Marking Information



XX = Product Type Marking Code  
(See Electrical Characteristics Table)



UDZ9V1BQ

## Thermal Characteristics

| Characteristic                                      | Symbol          | Value       | Unit          |
|---|-----------------|-------------|---------------|
| Power Dissipation (Note 5)                          | $P_D$           | 200         | mW            |
| Thermal Resistance Junction to Ambient Air (Note 5) | $R_{\theta JA}$ | 625         | $^{\circ}C/W$ |
| Operating and Storage Temperature Range             | $T_J, T_{STG}$  | -65 to +150 | $^{\circ}C$   |

## Electrical Characteristics (@ $T_A = +25^{\circ}C$ , unless otherwise specified.)

| Type Number | Marking Code | Zener Voltage Range (Note 6) |         |          | Maximum Zener Impedance (Note 7) |                   |          | Maximum Reverse Current (Note 6) |       |
|-------------|--------------|------------------------------|---------|----------|----------------------------------|-------------------|----------|----------------------------------|-------|
|             |              | $V_{ZT} @ I_{ZT}$            |         | $I_{ZT}$ | $Z_{ZT} @ I_{ZT}$                | $Z_{ZK} @ I_{ZK}$ | $I_{ZK}$ | $I_R$                            | $V_R$ |
|             |              | Min (V)                      | Max (V) | mA       | $\Omega$                         | mA                | $\mu A$  | V                                |       |
| UDZ9V1BQ    | BH           | 8.850                        | 9.230   | 5        | 30                               | 60                | 0.5      | 0.5                              | 6.0   |

- Notes:
- Part mounted on FR-4 PC board with recommended pad layout, which can be found on our website at <http://www.diodes.com/package-outlines.html>.
  - Short duration pulse test used to minimize self-heating effect.
  - The Zener impedances ( $Z_{ZT}$ ,  $Z_{ZK}$ ) are measured by superimposing a minute alternating current on the regulated current ( $I_Z$ ).

NEW PRODUCT



UDZ9V1BQ

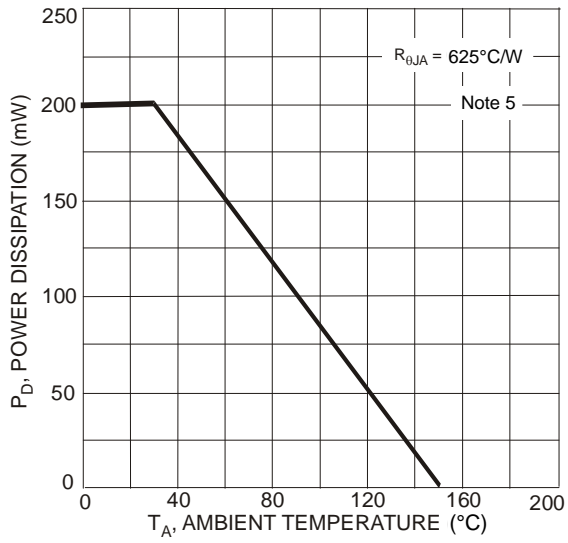

Fig. 1 Power Derating Curve

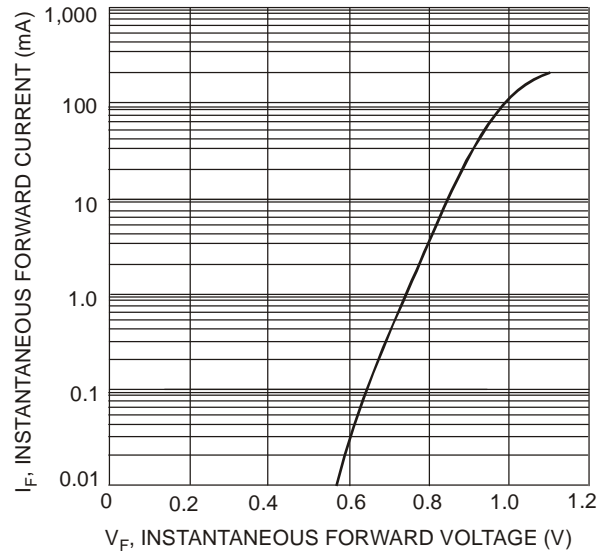

Fig. 2 Typical Forward Characteristics

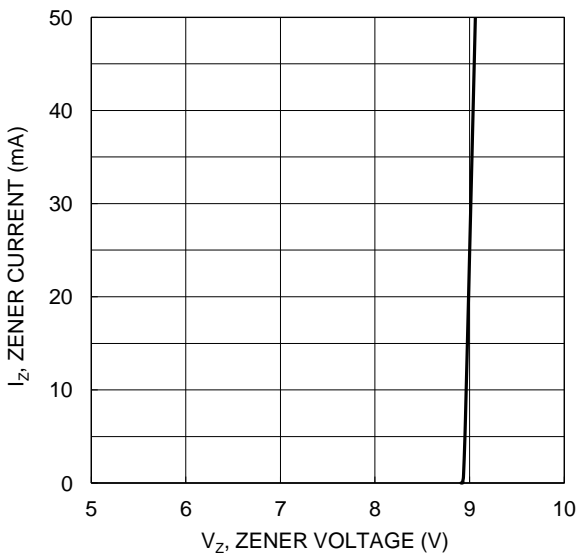

Fig. 3 Typical Zener Breakdown Characteristics

NEW PRODUCT

## Package Outline Dimensions

Please see <http://www.diodes.com/package-outlines.html> for the latest version.

SOD323

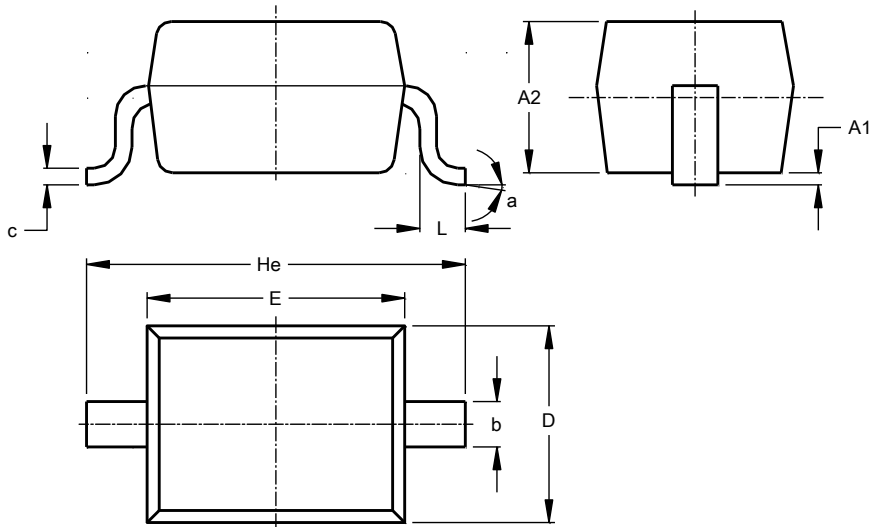

| SOD323               |      |      |      |
|----------------------|------|------|------|
| Dim                  | Min  | Max  | Typ  |
| A1                   | --   | 0.10 | 0.05 |
| A2                   | 1.00 | 1.10 | 1.05 |
| b                    | 0.25 | 0.35 | 0.30 |
| c                    | 0.10 | 0.15 | 0.11 |
| D                    | 1.20 | 1.40 | 1.30 |
| E                    | 1.60 | 1.80 | 1.70 |
| He                   | 2.30 | 2.70 | 2.50 |
| L                    | 0.20 | 0.40 | 0.30 |
| a                    | 0°   | 8°   | --   |
| All Dimensions in mm |      |      |      |

## Suggested Pad Layout

Please see <http://www.diodes.com/package-outlines.html> for the latest version.

SOD323

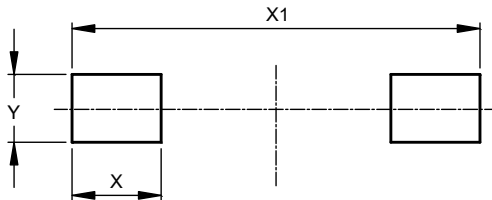

| Dimensions | Value (in mm) |
|------------|---------------|
| X          | 0.590         |
| X1         | 2.700         |
| Y          | 0.450         |



### IMPORTANT NOTICE

DIODES INCORPORATED MAKES NO WARRANTY OF ANY KIND, EXPRESS OR IMPLIED, WITH REGARDS TO THIS DOCUMENT, INCLUDING, BUT NOT LIMITED TO, THE IMPLIED WARRANTIES OF MERCHANTABILITY AND FITNESS FOR A PARTICULAR PURPOSE (AND THEIR EQUIVALENTS UNDER THE LAWS OF ANY JURISDICTION).

Diodes Incorporated and its subsidiaries reserve the right to make modifications, enhancements, improvements, corrections or other changes without further notice to this document and any product described herein. Diodes Incorporated does not assume any liability arising out of the application or use of this document or any product described herein; neither does Diodes Incorporated convey any license under its patent or trademark rights, nor the rights of others. Any Customer or user of this document or products described herein in such applications shall assume all risks of such use and will agree to hold Diodes Incorporated and all the companies whose products are represented on Diodes Incorporated website, harmless against all damages.

Diodes Incorporated does not warrant or accept any liability whatsoever in respect of any products purchased through unauthorized sales channel. Should Customers purchase or use Diodes Incorporated products for any unintended or unauthorized application, Customers shall indemnify and hold Diodes Incorporated and its representatives harmless against all claims, damages, expenses, and attorney fees arising out of, directly or indirectly, any claim of personal injury or death associated with such unintended or unauthorized application.

Products described herein may be covered by one or more United States, international or foreign patents pending. Product names and markings noted herein may also be covered by one or more United States, international or foreign trademarks.

This document is written in English but may be translated into multiple languages for reference. Only the English version of this document is the final and determinative format released by Diodes Incorporated.

### LIFE SUPPORT

Diodes Incorporated products are specifically not authorized for use as critical components in life support devices or systems without the express written approval of the Chief Executive Officer of Diodes Incorporated. As used herein:

A. Life support devices or systems are devices or systems which:

1. are intended to implant into the body, or
2. support or sustain life and whose failure to perform when properly used in accordance with instructions for use provided in the labeling can be reasonably expected to result in significant injury to the user.

B. A critical component is any component in a life support device or system whose failure to perform can be reasonably expected to cause the failure of the life support device or to affect its safety or effectiveness.

Customers represent that they have all necessary expertise in the safety and regulatory ramifications of their life support devices or systems, and acknowledge and agree that they are solely responsible for all legal, regulatory and safety-related requirements concerning their products and any use of Diodes Incorporated products in such safety-critical, life support devices or systems, notwithstanding any devices- or systems-related information or support that may be provided by Diodes Incorporated. Further, Customers must fully indemnify Diodes Incorporated and its representatives against any damages arising out of the use of Diodes Incorporated products in such safety-critical, life support devices or systems.

Copyright © 2019, Diodes Incorporated

[www.diodes.com](http://www.diodes.com)

## OUR CERTIFICATE

DiGi provide top-quality products and perfect service for customer worldwide through standardization, technological innovation and continuous improvement. DiGi through third-party certification, we stricly control the quality of products and services. Welcome your RFQ to

Email: [Info@DiGi-Electronics.com](mailto:Info@DiGi-Electronics.com)



Tel: +00 852-30501935

RFQ Email: [Info@DiGi-Electronics.com](mailto:Info@DiGi-Electronics.com)

DiGi is a global authorized distributor of electronic components.