

CS2000P-CZZ Datasheet

www.digi-electronics.com

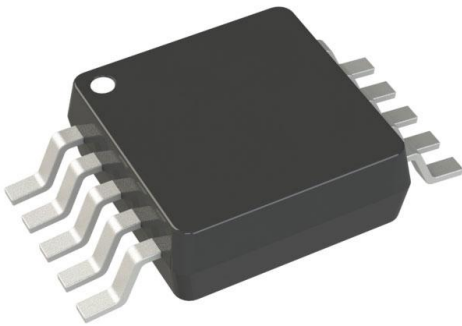

<https://www.DiGi-Electronics.com>

DiGi Electronics Part Number	CS2000P-CZZ-DG
Manufacturer	Cirrus Logic Inc.
Manufacturer Product Number	CS2000P-CZZ
Description	IC FRACT N SYNTH 10MSOP
Detailed Description	Fractional N Synthesizer IC 75MHz 1 10-TFSOP, 10-MSOP (0.118", 3.00mm Width)

This model CS2000P-CZZ is available at DiGi Electronics.

DiGi Electronics offers a global database of semiconductor and electronic component datasheets.

We welcome your inquiries regarding pricing, lead time, or other product-related questions.

 [Request a Quote](#)

 [Datasheet Search](#)



Tel: +00 852-30501935

RFQ Email: Info@DiGi-Electronics.com

DiGi is a global authorized distributor of electronic components.

Purchase and inquiry

Manufacturer Product Number:

CS2000P-CZZ

Series:

-

DiGi-Electronics Programmable:

Not Verified

PLL:

Yes

Output:

Clock

Ratio - Input:Output:

2:2

Frequency - Max:

75MHz

Voltage - Supply:

3.1V ~ 3.5V

Mounting Type:

Surface Mount

Supplier Device Package:

10-MSOP

Manufacturer:

Cirrus Logic Inc.

Product Status:

Last Time Buy

Type:

Fractional N Synthesizer

Input:

Clock

Number of Circuits:

1

Differential - Input:Output:

No/No

Divider/Multiplier:

Yes/Yes

Operating Temperature:

-10°C ~ 70°C

Package / Case:

10-TFSOP, 10-MSOP (0.118", 3.00mm Width)

Base Product Number:

CS2000

Environmental & Export classification

RoHS Status:

ROHS3 Compliant

REACH Status:

REACH Unaffected

HTSUS:

8542.39.0001

Moisture Sensitivity Level (MSL):

2 (1 Year)

ECCN:

EAR99

CS2000-OTP

Fractional-N Clock Synthesizer & Clock Multiplier

Features

- ◆ Delta-Sigma Fractional-N Frequency Synthesis
 - Generates a Low Jitter 6 - 75 MHz Clock from an 8 - 75 MHz Reference Clock
- ◆ Clock Multiplier / Jitter Reduction
 - Generates a Low Jitter 6 - 75 MHz Clock from a Jittery 50 Hz to 30 MHz Clock Source
- ◆ Highly Accurate PLL Multiplication Factor
 - Maximum Error Less Than 1 PPM in High-Resolution Mode
- ◆ One-Time Programmability
 - Configurable Hardware Control Pins
 - Configurable Auxiliary Output
- ◆ Flexible Sourcing of Reference Clock
 - External Oscillator or Clock Source
 - Supports Inexpensive Local Crystal
- ◆ Minimal Board Space Required
 - No External Analog Loop-filter Components

General Description

The CS2000-OTP is an extremely versatile system clocking device that utilizes a programmable phase lock loop. The CS2000-OTP is based on a hybrid analog-digital PLL architecture comprised of a unique combination of a Delta-Sigma Fractional-N Frequency Synthesizer and a Digital PLL. This architecture allows for both frequency synthesis/clock generation from a stable reference clock as well as generation of a low-jitter clock relative to an external noisy synchronization clock with frequencies as low as 50 Hz. The CS2000-OTP has many configuration options which are set once prior to runtime. At runtime there are three hardware configuration pins available for mode and feature selection.

The CS2000-OTP is available in a 10-pin MSOP package in Commercial (-10°C to +70°C) and Automotive-D (-40°C to +85°C) and Automotive-E (-40°C to +105°C) grades. Customer development kits are also available for custom device prototyping, small production programming, and device evaluation. Please see ["Ordering Information"](#) on page 29 for complete details.

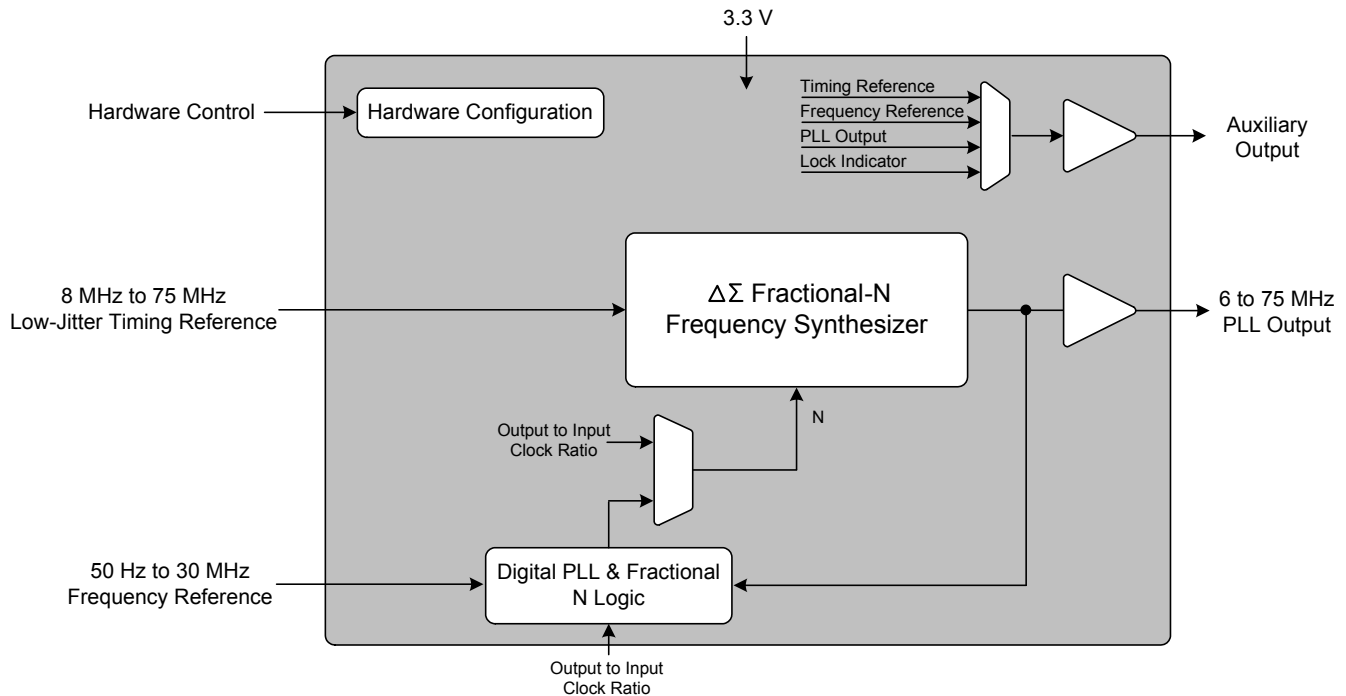



TABLE OF CONTENTS

1. PIN DESCRIPTION	4
2. TYPICAL CONNECTION DIAGRAM	5
3. CHARACTERISTICS AND SPECIFICATIONS	6
RECOMMENDED OPERATING CONDITIONS	6
ABSOLUTE MAXIMUM RATINGS	6
DC ELECTRICAL CHARACTERISTICS	6
AC ELECTRICAL CHARACTERISTICS	7
PLL PERFORMANCE PLOTS	8
4. ARCHITECTURE OVERVIEW	9
4.1 Delta-Sigma Fractional-N Frequency Synthesizer	9
4.2 Hybrid Analog-Digital Phase Locked Loop	9
4.2.1 Fractional-N Source Selection for the Frequency Synthesizer	10
5. APPLICATIONS	11
5.1 One Time Programmability	11
5.2 Timing Reference Clock Input	11
5.2.1 Internal Timing Reference Clock Divider	11
5.2.2 Crystal Connections (XTI and XTO)	12
5.2.3 External Reference Clock (REF_CLK)	12
5.3 Frequency Reference Clock Input, CLK_IN	12
5.3.1 Adjusting the Minimum Loop Bandwidth for CLK_IN	13
5.4 Output to Input Frequency Ratio Configuration	14
5.4.1 User Defined Ratio (RUD), Frequency Synthesizer Mode	14
5.4.2 User Defined Ratio (RUD), Hybrid PLL Mode	14
5.4.3 Ratio Modifier (R-Mod)	15
5.4.4 Effective Ratio (REFF)	15
5.4.5 Fractional-N Source Selection	15
5.4.5.1 Manual Fractional-N Source Selection for the Frequency Synthesizer	16
5.4.5.2 Automatic Fractional-N Source Selection for the Frequency Synthesizer	16
5.4.6 Ratio Configuration Summary	17
5.5 PLL Clock Output	18
5.6 Auxiliary Output	18
5.7 Mode Pin Functionality	19
5.7.1 M1 and M0 Mode Pin Functionality	19
5.7.2 M2 Mode Pin Functionality	19
5.7.2.1 M2 Configured as Output Disable	19
5.7.2.2 M2 Configured as R-Mod Enable	19
5.7.2.3 M2 Configured as Auto Fractional-N Source Selection Disable	20
5.7.2.4 M2 Configured as Fractional-N Source Select	20
5.7.2.5 M2 Configured as AuxOutSrc Override	20
5.8 Clock Output Stability Considerations	20
5.8.1 Output Switching	20
5.8.2 PLL Unlock Conditions	21
5.9 Required Power Up Sequencing for Programmed Devices	21
6. PARAMETER DESCRIPTIONS	22
6.1 Modal Configuration Sets	22
6.1.1 R-Mod Selection (RModSel[1:0])	22
6.1.2 Auxiliary Output Source Selection (AuxOutSrc[1:0])	23
6.1.3 Lock Clock Ratio (LockClk[1:0])	23
6.1.4 Fractional-N Source for Frequency Synthesizer (FracNSrc)	23
6.2 Ratio 0 - 3	23
6.3 Global Configuration Parameters	24
6.3.1 AUX PLL Lock Output Configuration (AuxLockCfg)	24



6.3.2 Reference Clock Input Divider (RefClkDiv[1:0])	24
6.3.3 Enable PLL Clock Output on Unlock (ClkOutUnl)	24
6.3.4 Low-Frequency Ratio Configuration (LFRatioCfg)	24
6.3.5 M2 Pin Configuration (M2Config[2:0])	25
6.3.6 Clock Input Bandwidth (ClkIn_BW[2:0])	25
7. CALCULATING THE USER DEFINED RATIO	26
7.1 High Resolution 12.20 Format	26
7.2 High Multiplication 20.12 Format	26
8. PROGRAMMING INFORMATION	27
9. PACKAGE DIMENSIONS	28
THERMAL CHARACTERISTICS	28
10. ORDERING INFORMATION	29
11. REVISION HISTORY	29

LIST OF FIGURES

Figure 1. Typical Connection Diagram	5
Figure 2. CLK_IN Sinusoidal Jitter Tolerance	8
Figure 3. CLK_IN Sinusoidal Jitter Transfer	8
Figure 4. CLK_IN Random Jitter Rejection and Tolerance	8
Figure 5. Delta-Sigma Fractional-N Frequency Synthesizer	9
Figure 6. Hybrid Analog-Digital PLL	10
Figure 7. Fractional-N Source Selection Overview	10
Figure 8. Internal Timing Reference Clock Divider	11
Figure 9. REF_CLK Frequency vs. a Fixed CLK_OUT	12
Figure 10. External Component Requirements for Crystal Circuit	12
Figure 11. Low bandwidth and new clock domain	13
Figure 12. High bandwidth with CLK_IN domain re-use	13
Figure 13. Ratio Feature Summary	17
Figure 14. PLL Clock Output Options	18
Figure 15. Auxiliary Output Selection	18
Figure 16. M2 Mapping Options	19
Figure 17. Parameter Configuration Sets	22

LIST OF TABLES

Table 1. Modal and Global Configuration	11
Table 2. Ratio Modifier	15
Table 3. Example 12.20 R-Values	26
Table 4. Example 20.12 R-Values	26

1. PIN DESCRIPTION

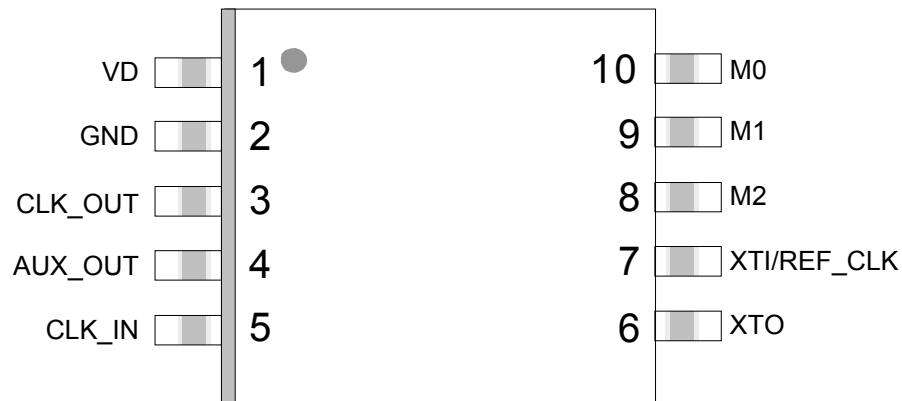

Pin Name	#	Pin Description
VD	1	Digital Power (Input) - Positive power supply for the digital and analog sections.
GND	2	Ground (Input) - Ground reference.
CLK_OUT	3	PLL Clock Output (Output) - PLL clock output.
AUX_OUT	4	Auxiliary Output (Output) - This pin outputs a buffered version of one of the input or output clocks, or a status signal, depending on configuration.
CLK_IN	5	Frequency Reference Clock Input (Input) - Clock input for the Digital PLL frequency reference.
XTO XTI/REF_CLK	6 7	Crystal Connections (XTI/XTO) / Timing Reference Clock Input (REF_CLK) (Input/Output) - XTI/XTO are I/O pins for an external crystal which may be used to generate the low-jitter PLL input clock. REF_CLK is an input for an externally generated low-jitter reference clock.
M2	8	Mode Select (Input) - M2 is a configurable mode selection pin.
M1	9	Mode Select (Input) - M1 is a configurable mode selection pin.
M0	10	Mode Select (Input) - M0 is a configurable mode selection pin.

2. TYPICAL CONNECTION DIAGRAM

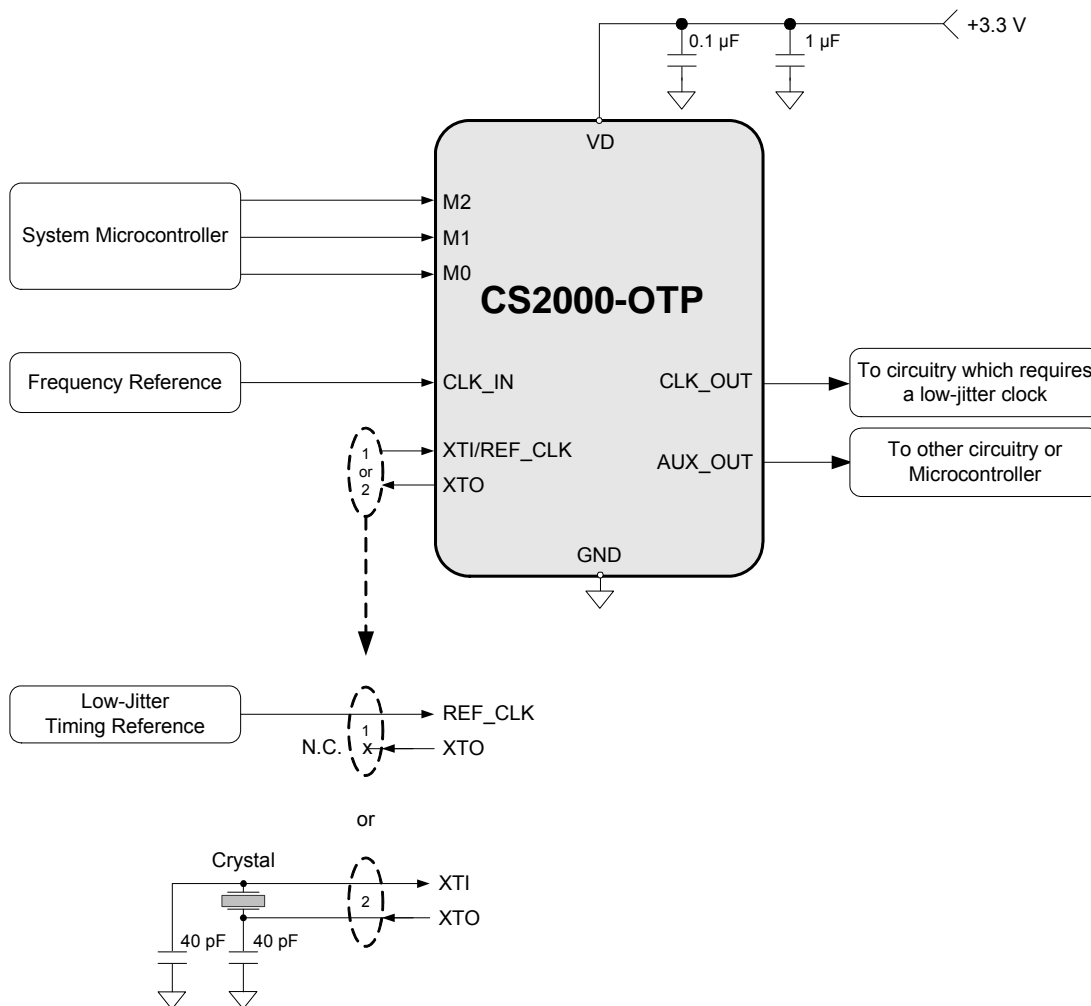

Figure 1. Typical Connection Diagram



3. CHARACTERISTICS AND SPECIFICATIONS

RECOMMENDED OPERATING CONDITIONS

GND = 0 V; all voltages with respect to ground. (Note 1)

Parameters	Symbol	Min	Typ	Max	Units
DC Power Supply (Note 2)	VD	3.1	3.3	3.5	V
Ambient Operating Temperature (Power Applied)					
Commercial Grade	T _{AC}	-10	-	+70	°C
Automotive-D Grade	T _{AD}	-40	-	+85	°C
Automotive-E Grade	T _{AE}	-40	-	+105	°C

- Notes:**
- Device functionality is not guaranteed or implied outside of these limits. Operation outside of these limits may adversely affect device reliability.
 - CLK_IN must not be applied when these conditions are not met, including during power up. See [section 5.9 on page 21](#) for required power up procedure.

ABSOLUTE MAXIMUM RATINGS

GND = 0 V; all voltages with respect to ground.

Parameters	Symbol	Min	Max	Units
DC Power Supply	VD	-0.3	6.0	V
Input Current	I _{IN}	-	±10	mA
Digital Input Voltage (Note 3)	V _{IN}	-0.3	VD + 0.4	V
Ambient Operating Temperature (Power Applied)	T _A	-55	125	°C
Storage Temperature	T _{stg}	-65	150	°C

WARNING: Operation at or beyond these limits may result in permanent damage to the device.

- Notes:**
- The maximum over/under voltage is limited by the input current except on the power supply pin.

DC ELECTRICAL CHARACTERISTICS

Test Conditions (unless otherwise specified): VD = 3.1 V to 3.5 V; T_A = -10°C to +70°C (Commercial Grade); T_A = -40°C to +85°C (Automotive-D Grade); T_A = -40°C to +105°C (Automotive-E Grade).

Parameters	Symbol	Min	Typ	Max	Units
Power Supply Current - Unloaded (Note 4)	I _D	-	12	18	mA
Power Dissipation - Unloaded (Note 4)	P _D	-	40	60	mW
Input Leakage Current	I _{IN}	-	-	±10	µA
Input Capacitance	I _C	-	8	-	pF
High-Level Input Voltage	V _{IH}	70%	-	-	VD
Low-Level Input Voltage	V _{IL}	-	-	30%	VD
High-Level Output Voltage (I _{OH} = -1.2 mA)	V _{OH}	80%	-	-	VD
Low-Level Output Voltage (I _{OH} = 1.2 mA)	V _{OL}	-	-	20%	VD

- Notes:**
- To calculate the additional current consumption due to loading (per output pin), multiply clock output frequency by load capacitance and power supply voltage.
For example, f_{CLK_OUT} (49.152 MHz) * C_L (15 pF) * VD (3.3 V) = 2.4 mA of additional current due to these loading conditions on CLK_OUT.



AC ELECTRICAL CHARACTERISTICS

Test Conditions (unless otherwise specified): $V_D = 3.1\text{ V to }3.5\text{ V}$; $T_A = -10^\circ\text{C to }+70^\circ\text{C}$ (Commercial Grade);
 $T_A = -40^\circ\text{C to }+85^\circ\text{C}$ (Automotive-D Grade); $T_A = -40^\circ\text{C to }+105^\circ\text{C}$ (Automotive-E Grade); $C_L = 15\text{ pF}$.

Parameters	Symbol	Conditions	Min	Typ	Max	Units
Crystal Frequency Fundamental Mode XTAL	f_{XTAL}	$\text{RefClkDiv}[1:0] = 10$	8	-	14	MHz
		$\text{RefClkDiv}[1:0] = 01$	16	-	28	MHz
		$\text{RefClkDiv}[1:0] = 00$	32	-	50	MHz
Reference Clock Input Frequency	$f_{\text{REF_CLK}}$	$\text{RefClkDiv}[1:0] = 10$	8	-	14	MHz
		$\text{RefClkDiv}[1:0] = 01$	16	-	28	MHz
		$\text{RefClkDiv}[1:0] = 00$	32	-	56	MHz
Reference Clock Input Duty Cycle	$D_{\text{REF_CLK}}$		45	-	55	%
Internal System Clock Frequency	$f_{\text{SYS_CLK}}$		8		14	MHz
Clock Input Frequency	$f_{\text{CLK_IN}}$		50 Hz	-	30	MHz
Clock Input Pulse Width (Note 5)	$PW_{\text{CLK_IN}}$	$f_{\text{CLK_IN}} < f_{\text{SYS_CLK}}/96$	2	-	-	UI
		$f_{\text{CLK_IN}} > f_{\text{SYS_CLK}}/96$	10	-	-	ns
PLL Clock Output Frequency	$f_{\text{CLK_OUT}}$	(Note 6)	6	-	75	MHz
PLL Clock Output Duty Cycle	t_{OD}	Measured at $V_D/2$	45	50	55	%
Clock Output Rise Time	t_{OR}	20% to 80% of V_D	-	1.7	3.0	ns
Clock Output Fall Time	t_{OF}	80% to 20% of V_D	-	1.7	3.0	ns
Period Jitter	t_{JIT}	(Note 7)	-	70	-	ps rms
Base Band Jitter (100 Hz to 40 kHz)		(Notes 7, 8)	-	50	-	ps rms
Wide Band Jitter (100 Hz Corner)		(Notes 7, 9)	-	175	-	ps rms
PLL Lock Time - CLK_IN (Note 10)	t_{LC}	$f_{\text{CLK_IN}} < 200\text{ kHz}$	-	100	200	UI
		$f_{\text{CLK_IN}} > 200\text{ kHz}$	-	1	3	ms
PLL Lock Time - REF_CLK	t_{LR}	$f_{\text{REF_CLK}} = 8\text{ to }75\text{ MHz}$	-	1	3	ms
Output Frequency Synthesis Resolution (Note 11)	f_{err}	High Resolution	0	-	± 0.5	ppm
		High Multiplication	0	-	± 112	ppm

- Notes:**
- 1 UI (unit interval) corresponds to $t_{\text{SYS_CLK}}$ or $1/f_{\text{SYS_CLK}}$.
 - $f_{\text{CLK_OUT}}$ is ratio-limited when $f_{\text{CLK_IN}}$ is below 72 Hz.
 - $f_{\text{CLK_OUT}} = 24.576\text{ MHz}$; Sample size = 10,000 points; $\text{AuxOutSrc}[1:0] = 11$.
 - In accordance with AES-12id-2006 section 3.4.2. Measurements are Time Interval Error taken with 3rd order 100 Hz to 40 kHz bandpass filter.
 - In accordance with AES-12id-2006 section 3.4.1. Measurements are Time Interval Error taken with 3rd order 100 Hz Highpass filter.
 - 1 UI (unit interval) corresponds to $t_{\text{CLK_IN}}$ or $1/f_{\text{CLK_IN}}$.
 - The frequency accuracy of the PLL clock output is directly proportional to the frequency accuracy of the reference clock.

PLL PERFORMANCE PLOTS

Test Conditions (unless otherwise specified): $V_D = 3.3\text{ V}$; $T_A = 25\text{ }^\circ\text{C}$; $C_L = 15\text{ pF}$; $f_{\text{CLK_OUT}} = 12.288\text{ MHz}$; $f_{\text{CLK_IN}} = 12.288\text{ MHz}$; Sample size = 10,000 points; Base Band Jitter (100 Hz to 40 kHz); $\text{AuxOutSrc}[1:0] = 11$.

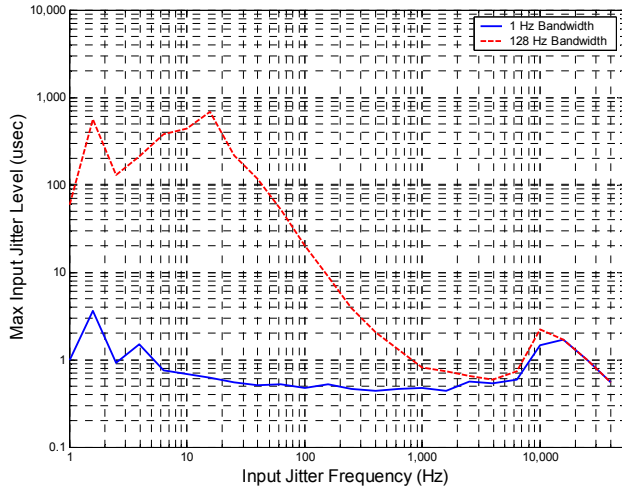

Figure 2. CLK_IN Sinusoidal Jitter Tolerance

Samples size = 2.5M points; Base Band Jitter (100Hz to 40kHz).

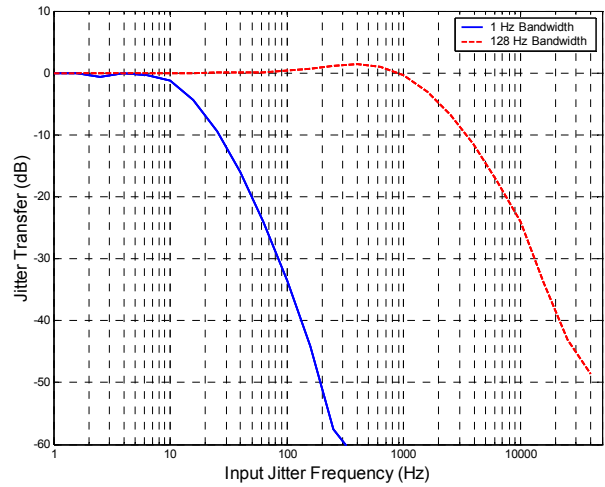

Figure 3. CLK_IN Sinusoidal Jitter Transfer

Samples size = 2.5M points; Base Band Jitter (100Hz to 40kHz).

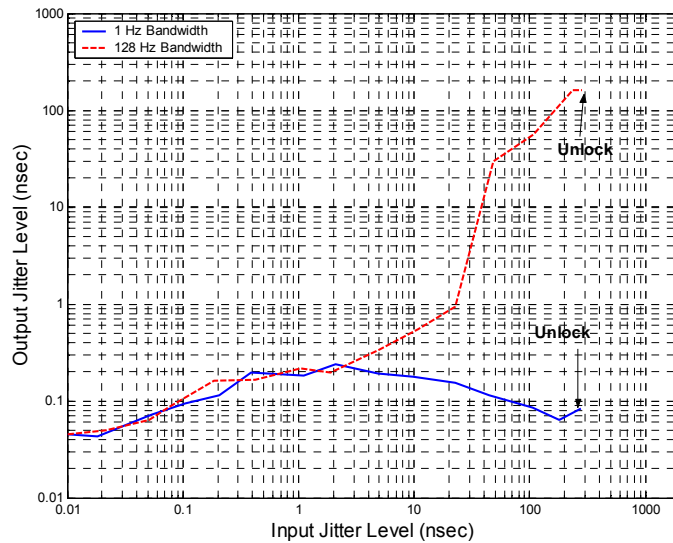

Figure 4. CLK_IN Random Jitter Rejection and Tolerance

4. ARCHITECTURE OVERVIEW

4.1 Delta-Sigma Fractional-N Frequency Synthesizer

The core of the CS2000 is a Delta-Sigma Fractional-N Frequency Synthesizer which has very high-resolution for Input/Output clock ratios, low phase noise, very wide range of output frequencies and the ability to quickly tune to a new frequency. In very simplistic terms, the Fractional-N Frequency Synthesizer multiplies the Timing Reference Clock by the value of N to generate the PLL output clock. The desired output to input clock ratio is the value of N that is applied to the delta-sigma modulator (see [Figure 5](#)).

The analog PLL based frequency synthesizer uses a low-jitter timing reference clock as a time and phase reference for the internal voltage controlled oscillator (VCO). The phase comparator compares the fractional-N divided clock with the original timing reference and generates a control signal. The control signal is filtered by the internal loop filter to generate the VCO's control voltage which sets its output frequency. The delta-sigma modulator modulates the loop integer divide ratio to get the desired fractional ratio between the reference clock and the VCO output (thus the duty cycle of the modulator sets the fractional value). This allows the design to be optimized for very fast lock times for a wide range of output frequencies without the need for external filter components. As with any Fractional-N Frequency Synthesizer the timing reference clock should be stable and jitter-free.

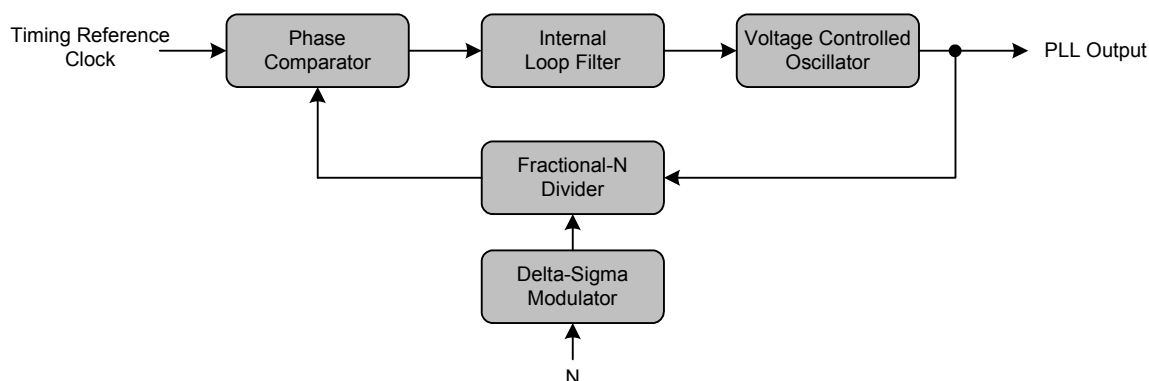
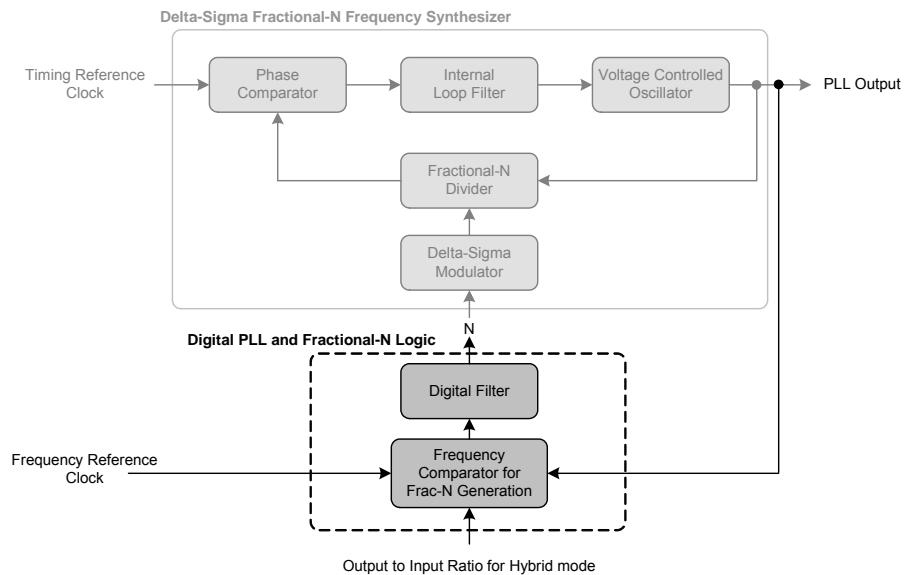

Figure 5. Delta-Sigma Fractional-N Frequency Synthesizer

4.2 Hybrid Analog-Digital Phase Locked Loop

The addition of the Digital PLL and Fractional-N Logic (shown in [Figure 6](#)) to the Fractional-N Frequency Synthesizer creates the Hybrid Analog-Digital Phase Locked Loop with many advantages over classical analog PLL techniques. These advantages include the ability to operate over extremely wide frequency ranges without the need to change external loop filter components while maintaining impressive jitter reduction performance. In the Hybrid architecture, the Digital PLL calculates the ratio of the PLL output clock to the frequency reference and compares that to the desired ratio. The digital logic generates a value of N which is then applied to the Fractional-N frequency synthesizer to generate the desired PLL output frequency. Notice that the frequency and phase of the timing reference signal do not affect the output of the PLL since the digital control loop will correct for the PLL output. A major advantage of the Digital PLL is the ease with which the loop filter bandwidth can be altered. The PLL bandwidth is set to a wide-bandwidth mode to quickly achieve lock and then reduced for optimal jitter rejection.

**Figure 6. Hybrid Analog-Digital PLL**

4.2.1 Fractional-N Source Selection for the Frequency Synthesizer

The fractional-N value for the frequency synthesizer can be sourced from either a static ratio or a dynamic ratio generated from the digital PLL (see Figure 7). This allows for the selection between operating in the static ratio based Frequency Synthesizer Mode as a simple frequency synthesizer (for frequency generation from the Timing Reference Clock) and in the dynamic ratio based Hybrid PLL Mode (for jitter reduction and clock multiplication). Selection between these two modes can either be made automatically based on the presence of the Frequency Reference Clock or manually through the mode select pins.

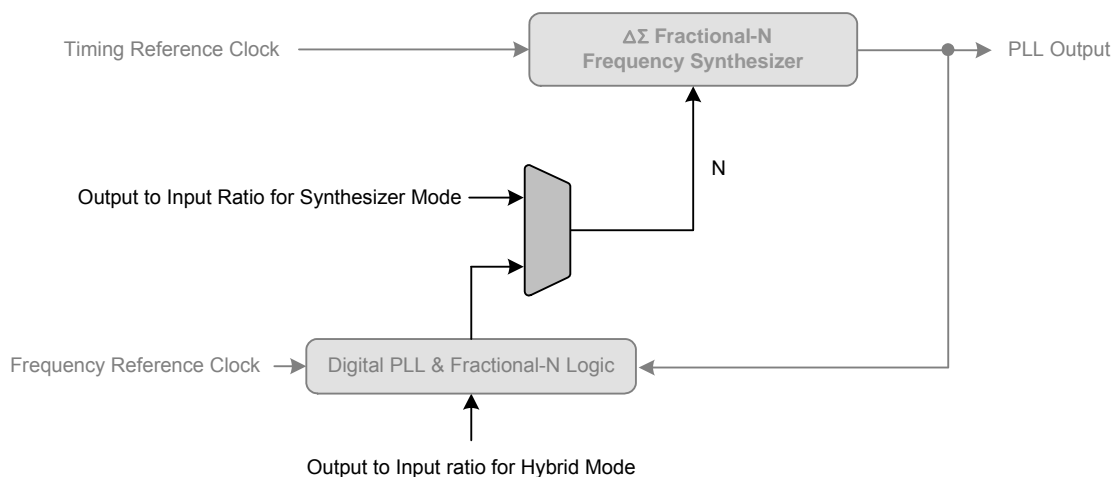
**Figure 7. Fractional-N Source Selection Overview**

5. APPLICATIONS

5.1 One Time Programmability

The one time programmable (OTP) circuitry in the CS2000-OTP allows for pre-configuration of the device prior to use in a system. There are two types of parameters that are used for device pre-configuration: *modal* and *global*. The *modal* parameters are features which, when grouped together, create a modal configuration set (see [Figure 17 on page 22](#)). Up to four modal configuration sets can be permanently stored and then dynamically selected using the M[1:0] mode select pins (see [Table 1](#)). The *global* parameters are the remaining configuration settings which do not change with the mode select pins. The modal and global parameters can be pre-set at the factory or user programmed using the customer development kit, CDK2000; Please see “[Programming Information](#)” on [page 27](#) for more details.

Parameter Type	M[1:0] pins = 00	M[1:0] pins = 01	M[1:0] pins = 10	M[1:0] pins = 11
Modal	Configuration Set 0 Ratio 0	Configuration Set 1 Ratio 1	Configuration Set 2 Ratio 2	Configuration Set 3 Ratio 3
Global	Configuration settings set once for all modes.			

Table 1. Modal and Global Configuration

5.2 Timing Reference Clock Input

The low jitter timing reference clock (RefClk) can be provided by either an external reference clock or an external crystal in conjunction with the internal oscillator. In order to maintain a stable and low-jitter PLL output the timing reference clock must also be stable and low-jitter; the quality of the timing reference clock directly affects the performance of the PLL and hence the quality of the PLL output.

5.2.1 Internal Timing Reference Clock Divider

The Internal Timing Reference Clock (SysClk) is limited to a lower maximum frequency than that allowed on the XTI/REF_CLK pin. The CS2000-OTP supports the wider external frequency range by offering an internal divider for RefClk. The *RefClkDiv[1:0]* global parameter should be configured such that SysClk, the divided RefClk, then falls within the valid range as indicated in “[AC Electrical Characteristics](#)” on [page 7](#).

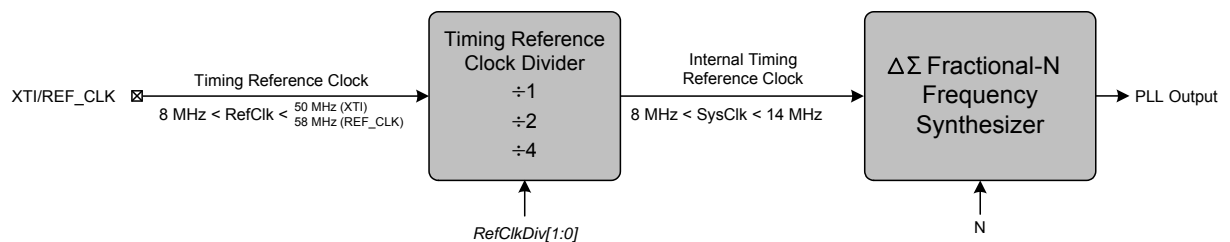

Figure 8. Internal Timing Reference Clock Divider

It should be noted that the maximum allowable input frequency of the XTI/REF_CLK pin is dependent upon its configuration as either a crystal connection or external clock input. See the “[AC Electrical Characteristics](#)” on [page 7](#) for more details.

For the lowest possible output jitter, attention should be paid to the absolute frequency of the Timing Reference Clock relative to the PLL Output frequency (CLK_OUT). To minimize output jitter, the Timing Reference Clock frequency should be chosen such that f_{RefClk} is at least ± 15 kHz from $f_{\text{CLK_OUT}} \cdot N/32$ where N is an integer. [Figure 9](#) shows the effect of varying the RefClk frequency around $f_{\text{CLK_OUT}} \cdot N/32$. It should be noted that there will be a jitter null at the zero point when $N = 32$ (not shown in [Figure 9](#)). An

example of how to determine the range of RefClk frequencies around 12 MHz to be used in order to achieve the lowest jitter PLL output at a frequency of 12.288 MHz is as follows:

$f_L \leq f_{RefClk} \leq f_H$ where:

$$\begin{aligned} f_L &= f_{CLK_OUT} \times \frac{31}{32} + 15kHz \\ &= 12.288MHz \times 0.96875 + 15kHz \\ &= 11.919MHz \end{aligned}$$

and

$$\begin{aligned} f_H &= f_{CLK_OUT} \times \frac{32}{32} - 15kHz \\ &= 12.288MHz \times 1 - 15kHz \\ &= 12.273MHz \end{aligned}$$

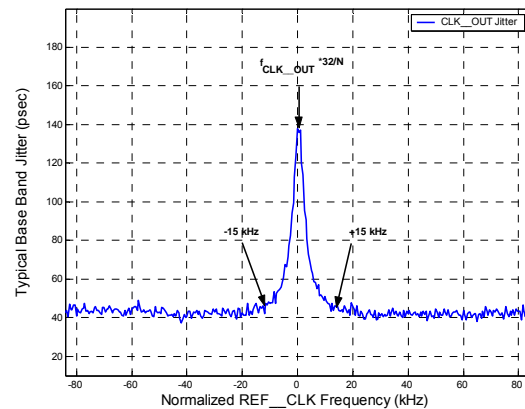

Figure 9. REF_CLK Frequency vs. a Fixed CLK_OUT

Referenced Control	Parameter Definition
RefClkDiv[1:0]"Reference Clock Input Divider (RefClkDiv[1:0])" on page 24

5.2.2 Crystal Connections (XTI and XTO)

An external crystal may be used to generate RefClk. To accomplish this, a 20 pF fundamental mode parallel resonant crystal must be connected between the XTI and XTO pins as shown in [Figure 10](#). As shown, nothing other than the crystal and its load capacitors should be connected to XTI and XTO. Please refer to the "[AC Electrical Characteristics](#)" on page 7 for the allowed crystal frequency range.

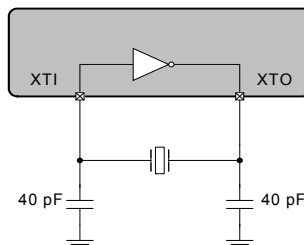

Figure 10. External Component Requirements for Crystal Circuit

5.2.3 External Reference Clock (REF_CLK)

For operation with an externally generated REF_CLK signal, XTI/REF_CLK should be connected to the reference clock source and XTO should be left unconnected or terminated through a 47 kΩ resistor to GND.

5.3 Frequency Reference Clock Input, CLK_IN

The frequency reference clock input (CLK_IN) is used in Hybrid PLL Mode by the Digital PLL and Fractional-N Logic block to dynamically generate a fractional-N value for the Frequency Synthesizer (see "[Hybrid Analog-Digital PLL](#)" on page 10). The Digital PLL first compares the CLK_IN frequency to the PLL output. The Fractional-N logic block then translates the desired ratio based off of CLK_IN to one based off of the internal timing reference clock (SysClk). This allows the low-jitter timing reference clock to be used as the clock

which the Frequency Synthesizer multiplies while maintaining synchronicity with the frequency reference clock through the Digital PLL. The allowable frequency range for CLK_IN is found in the “AC Electrical Characteristics” on page 7.

5.3.1 Adjusting the Minimum Loop Bandwidth for CLK_IN

The CS2000 allows the minimum loop bandwidth of the Digital PLL to be adjusted between 1 Hz and 128 Hz using the *ClkIn_BW[2:0]* global parameter. The minimum loop bandwidth of the Digital PLL directly affects the jitter transfer function; specifically, jitter frequencies below the loop bandwidth corner are passed from the PLL input directly to the PLL output without attenuation. In some applications it is desirable to have a very low minimum loop bandwidth to reject very low jitter frequencies, commonly referred to as wander. In others it may be preferable to remove only higher frequency jitter, allowing the input wander to pass through the PLL without attenuation.

Typically, applications in which the PLL_OUT signal creates a new clock domain from which all other system clocks and associated data are derived will benefit from the maximum jitter and wander rejection of the lowest PLL bandwidth setting. See Figure 11.

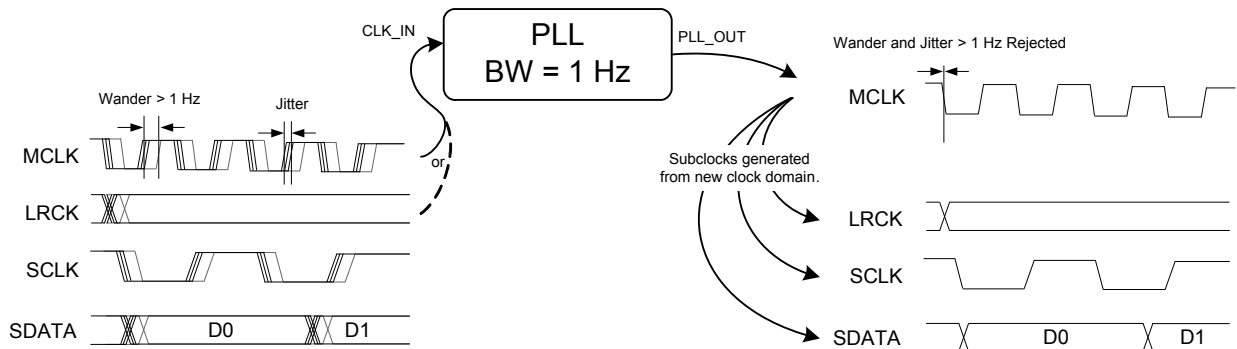

Figure 11. Low bandwidth and new clock domain

Systems in which some clocks and data are derived from the PLL_OUT signal while other clocks and data are derived from the CLK_IN signal will often require phase alignment of all the clocks and data in the system. See Figure 12. If there is substantial wander on the CLK_IN signal in these applications, it may be necessary to increase the minimum loop bandwidth allowing this wander to pass through to the CLK_OUT signal in order to maintain phase alignment. For these applications, it is advised to experiment with the loop bandwidth settings and choose the lowest bandwidth setting that does not produce system timing errors due to wandering between the clocks and data synchronous to the CLK_IN domain and those synchronous to the PLL_OUT domain.

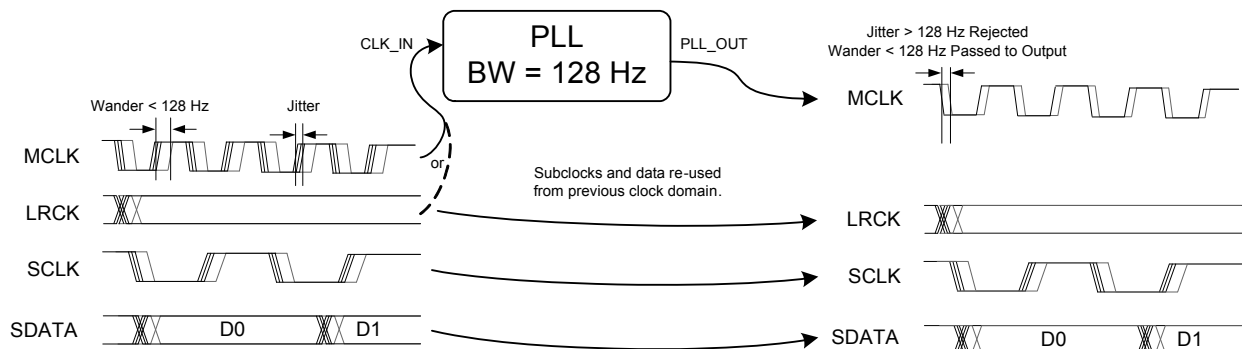

Figure 12. High bandwidth with CLK_IN domain re-use

While acquiring lock, the digital loop bandwidth is automatically set to a large value. Once lock is achieved, the digital loop bandwidth will settle to the minimum value selected by the *ClkIn_BW[2:0]* parameter.

Referenced Control	Parameter Definition
ClkIn_BW[2:0]	"Clock Input Bandwidth (ClkIn_BW[2:0])" on page 25

5.4 Output to Input Frequency Ratio Configuration

5.4.1 User Defined Ratio (R_{UD}), Frequency Synthesizer Mode

The User Defined Ratio, R_{UD} , is a 32-bit un-signed fixed-point number which determines the basis for the desired input to output clock ratio. Up to four different ratios, $Ratio_{0-3}$, can be stored in the CS2000's one time programmable memory. Selection between the four ratios is achieved by the M[1:0] mode select pins. The 32-bit R_{UD} is represented in a high-resolution 12.20 format where the 12 MSBs represent the integer binary portion while the remaining 20 LSBs represent the fractional binary portion. The maximum multiplication factor is approximately 4096 with a resolution of 0.954 PPM in this configuration. See "Calculating the User Defined Ratio" on page 26 for more information.

The status of internal dividers, such as the internal timing reference clock divider, are automatically taken into account. Therefore R_{UD} is simply the desired ratio of the output to input clock frequencies.

Referenced Control	Parameter Definition
Ratio 0-3.....	"Ratio 0 - 3" on page 23
M[1:0].....	"M1 and M0 Mode Pin Functionality" on page 19

5.4.2 User Defined Ratio (R_{UD}), Hybrid PLL Mode

The same four ratio locations, $Ratio_{0-3}$, are used to store the User Defined Ratios for Hybrid PLL Mode. Selection of the User Defined Ratio for the dynamic ratio based Hybrid PLL Mode is made with the M[1:0] pins (unless auto fractional N source selection is enabled; see section 5.4.5 on page 15).

In addition to the High-Resolution ratio format, a High-Multiplication format is also available. In the High-Multiplication format mode, the 32-bit fixed-point number for R_{UD} is represented in a 20.12 format where the 20 MSBs represent the integer binary portion while the remaining 12 LSBs represent the fractional binary portion. In this configuration, the maximum multiplication factor is approximately 1,048,575 with a resolution of 244 PPM.

The 20.12 format is enabled by the *LFRatioCfg* global parameter. The 20.12 ratio format is only available when the device is running in Hybrid PLL Mode. In Auto Fractional-N Source Selection Mode (see section 5.4.5.2 on page 16) when CLK_IN is not present the *LFRatioCfg* parameter is ignored and the ratio format is 12.20.

It is recommended that the 12.20 High-Resolution format be utilized whenever the desired ratio is less than 4096 since the output frequency accuracy of the PLL is directly proportional to the accuracy of the timing reference clock and the resolution of the R_{UD} .

Referenced Control	Parameter Definition
LockClk[1:0]	"Lock Clock Ratio (LockClk[1:0])" section on page 23
LFRatioCfg.....	"Low-Frequency Ratio Configuration (LFRatioCfg)" on page 24
FracNSrc.....	"Fractional-N Source for Frequency Synthesizer (FracNSrc)" section on page 23

5.4.3 Ratio Modifier (R-Mod)

The Ratio Modifier is used to internally multiply/divide the currently addressed R_{UD} ($Ratio_{0-3}$ stored in the register space remain unchanged). The available options for R-Mod are summarized in [Table 2 on page 15](#). R-Mod is enabled via the M2 pin in conjunction with the appropriate setting of the $M2Config[2:0]$ global parameter (see [Section 5.7.2 on page 19](#)).

RModSel[1:0]	R Modifier
00	0.5
01	0.25
10	0.125
11	0.0625

Table 2. Ratio Modifier

Referenced Control	Parameter Definition
Ratio 0-3.....	"Ratio 0 - 3" on page 23
RModSel[1:0]	"R-Mod Selection (RModSel[1:0])" section on page 22
M2Config[2:0].....	"M2 Pin Configuration (M2Config[2:0])" on page 25

5.4.4 Effective Ratio (R_{EFF})

The Effective Ratio (R_{EFF}) is an internal calculation comprised of R_{UD} and the appropriate modifiers, as previously described. R_{EFF} is calculated as follows:

$$R_{EFF} = R_{UD} \bullet \text{R-Mod}$$

To simplify operation the device handles some of the ratio calculation functions automatically (such as when the internal timing reference clock divider is set). For this reason, the Effective Ratio does not need to be altered to account for internal dividers.

Ratio modifiers which would produce an overflow or truncation of R_{EFF} should not be used. In all cases, the maximum and minimum allowable values for R_{EFF} are dictated by the frequency limits for both the input and output clocks as shown in the ["AC Electrical Characteristics" on page 7](#).

Selection of the user defined ratio from the four stored ratios is made by using the M[1:0] pins unless auto clock switching is enabled in which case the $LockClk[1:0]$ modal parameter also selects the ratio (see ["Fractional-N Source Selection" on page 15](#)).

Referenced Control	Parameter Definition
M[1:0] pins.....	"M1 and M0 Mode Pin Functionality" on page 19
LockClk[1:0]	"Lock Clock Ratio (LockClk[1:0])" section on page 23

5.4.5 Fractional-N Source Selection

To select between the static ratio based Frequency Synthesizer Mode and the dynamic ratio based Hybrid PLL Mode, the source for the fractional-N value for the Frequency Synthesizer must be changed. The Fractional-N value can either be sourced directly from the Effective Ratio (static ratio) or from the output of the Digital PLL (dynamic ratio) (see [Figure 13 on page 17](#)). The setting of this function can be made manual or automatically depending on the presence of CLK_IN.

5.4.5.1 Manual Fractional-N Source Selection for the Frequency Synthesizer

Manual selection of the fractional-N source for the frequency synthesizer can be done in one of two ways. The *FracNSrc* modal parameter can be set to the desired setting for each available configuration mode and then the Fractional N source is selected by the M1 and M0 pins. In order for this manual selection to work, the *LockClk[1:0]* modal parameter (even if unused) must be set to the same value as the modal ratio (Ratio 0 for Mode 0, Ratio 1 for Mode 1, etc.), see [Section 5.4.5.2 on page 16](#). Alternatively, the M2 pin in conjunction with the *M2Config[2:0]* global parameter can be set to control the fractional N source directly and thus override the *FracNSrc* modal parameter (see [Section 5.7.2.4 on page 20](#) for details).

Referenced Control	Parameter Definition
M[1:0] pins	"M1 and M0 Mode Pin Functionality" on page 19
LockClk[1:0]	"Lock Clock Ratio (LockClk[1:0])" section on page 23
FracNSrc.....	"Fractional-N Source for Frequency Synthesizer (FracNSrc)" section on page 23
M2Config[2:0]	"M2 Pin Configuration (M2Config[2:0])" on page 25

5.4.5.2 Automatic Fractional-N Source Selection for the Frequency Synthesizer

Automatic source selection allows for the selection of the frequency synthesizer's fractional-N value to be made dependent on the presence of the CLK_IN signal. When CLK_IN is present the device will use the dynamic ratio generated from the Digital PLL and CLK_IN for Hybrid PLL Mode. When CLK_IN is not present, the device will use RefClk and the static ratio for Frequency Synthesizer Mode. After losing CLK_IN, the CS2000-OTP will wait for 2²³ SysClk cycles before switching to SysClk and re-acquiring lock, during which time the PLL is unlocked

The modal ratio location (see [Table 1 on page 11](#)) should contain the desired CLK_OUT to RefClk ratio to be used when CLK_IN is not present. The User Defined Ratio pointed to by *LockClk[1:0]* should contain the desired CLK_OUT to CLK_IN ratio to be used when CLK_IN is present. Automatic source selection is enabled when the *LockClk[1:0]* modal parameter is set to a different User Defined Ratio from the modal ratio location.

When automatic source selection is enabled, the *FracNSrc* modal parameter (used for manual clock selection) will be ignored.

The automatic source selection feature can be disabled by setting the *LockClk[1:0]* modal parameter to the modal ratio location. The *FracNSrc* modal parameter must then be used to select the desired clock used for the PLL's frequency reference. The automatic source selection feature can also be disabled by using the M2 pin in conjunction with the *M2Config[2:0]* global parameter.

Referenced Control	Parameter Definition
M[1:0] pins	"M1 and M0 Mode Pin Functionality" on page 19
LockClk[1:0]	"Lock Clock Ratio (LockClk[1:0])" section on page 23
FracNSrc.....	"Fractional-N Source for Frequency Synthesizer (FracNSrc)" section on page 23
M2Config[2:0]	"M2 Pin Configuration (M2Config[2:0])" on page 25

5.4.6 Ratio Configuration Summary

The R_{UD} is the user defined ratio for which up to four different values ($Ratio_{0-3}$) can be stored in the one time programmable memory. The $M[1:0]$ pins or $LockClk[1:0]$ modal parameter then select the user defined ratio to be used (depending on if static or dynamic ratio mode is to be used). The resolution for the R_{UD} is selectable for the dynamic ratio mode. R-Mod is applied accordingly. The user defined ratio, ratio modifier, and automatic ratio modifier make up the effective ratio R_{EFF} , the final calculation used to determine the output to input clock ratio. The effective ratio is then corrected for the internal dividers. The frequency synthesizer's fractional-N source selection is made between the static ratio (in frequency synthesizer mode) or the dynamic ratio generated from the digital PLL (in Hybrid PLL mode) by either the $FracNSrc$ modal parameter for manual mode or the presence of CLK_IN in automatic mode. The conceptual diagram in Figure 13 summarizes the features involved in the calculation of the ratio values used to generate the fractional-N value which controls the Frequency Synthesizer. The subscript '4' indicates the modal parameters.

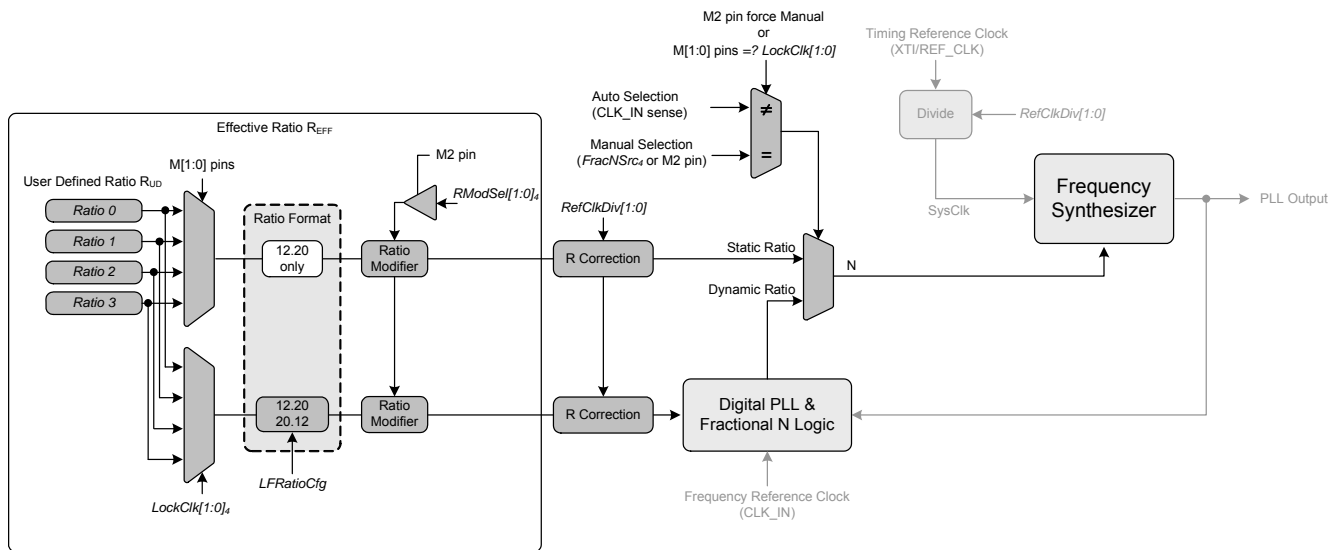

Figure 13. Ratio Feature Summary

Referenced Control	Parameter Definition
Ratio 0-3.....	"Ratio 0 - 3" on page 23
$M[1:0]$ pins.....	"M1 and M0 Mode Pin Functionality" on page 19
$LockClk[1:0]$	"Lock Clock Ratio ($LockClk[1:0]$)" section on page 23
$LFRatioCfg$	"Low-Frequency Ratio Configuration ($LFRatioCfg$)" on page 24
$RModSel[1:0]$	"R-Mod Selection ($RModSel[1:0]$)" section on page 22
$RefClkDiv[1:0]$	"Reference Clock Input Divider ($RefClkDiv[1:0]$)" on page 24
$FracNSrc$	"Fractional-N Source for Frequency Synthesizer ($FracNSrc$)" section on page 23

5.5 PLL Clock Output

The PLL clock output pin (CLK_OUT) provides a buffered version of the output of the frequency synthesizer. The driver can be set to high-impedance with the M2 pin when the *M2Config[1:0]* global parameter is set to either 000 or 010. The output from the PLL automatically drives a static low condition while the PLL is unlocked (when the clock may be unreliable). This feature can be disabled by setting the *ClkOutUnl* global parameter, however the state CLK_OUT may then be unreliable during an unlock condition.

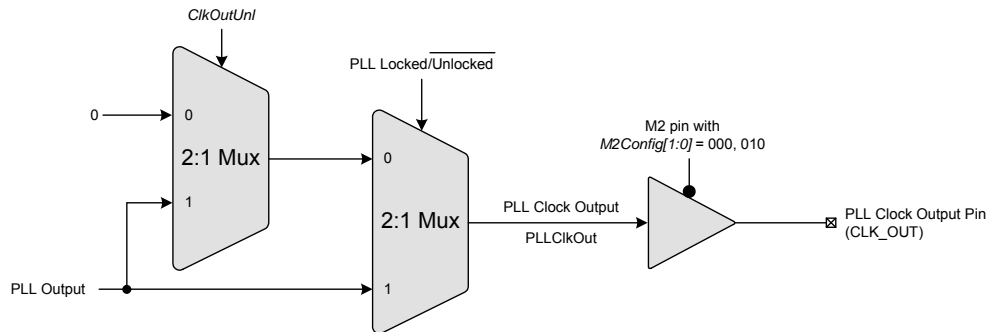

Figure 14. PLL Clock Output Options

Referenced Control	Parameter Definition
ClkOutUnl.....	“Enable PLL Clock Output on Unlock (ClkOutUnl)” on page 24
ClkOutDis.....	“M2 Configured as Output Disable” on page 19
M2Config[2:0].....	“M2 Pin Configuration (M2Config[2:0])” on page 25

5.6 Auxiliary Output

The auxiliary output pin (AUX_OUT) can be mapped, as shown in [Figure 15](#), to one of four signals: reference clock (RefClk), input clock (CLK_IN), additional PLL clock output (CLK_OUT), or a PLL lock indicator (Lock). The mux is controlled via the *AuxOutSrc[1:0]* modal parameter. If AUX_OUT is set to Lock, the *AuxLockCfg* global parameter is then used to control the output driver type and polarity of the LOCK signal (see [section 6.3.1 on page 24](#)). In order to indicate an unlock condition, REF_CLK must be present. If AUX_OUT is set to CLK_OUT, the phase of the PLL Clock Output signal on AUX_OUT may differ from the CLK_OUT pin. The driver for the pin can be set to high-impedance using the M2 pin when the *M2Config[1:0]* global parameter is set to either 001 or 010.

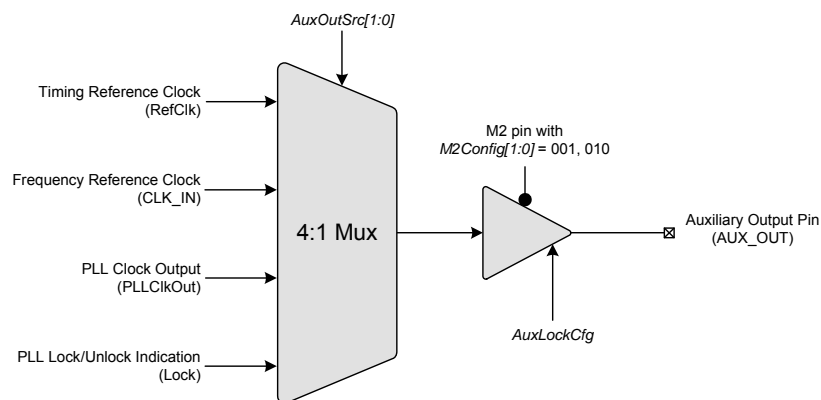

Figure 15. Auxiliary Output Selection

Referenced Control	Parameter Definition
AuxOutSrc[1:0].....	“Auxiliary Output Source Selection (AuxOutSrc[1:0])” on page 23
AuxOutDis.....	“M2 Configured as Output Disable” on page 19
AuxLockCfg.....	“AUX PLL Lock Output Configuration (AuxLockCfg)” section on page 24
M2Config[2:0].....	“M2 Pin Configuration (M2Config[2:0])” on page 25

5.7 Mode Pin Functionality

5.7.1 M1 and M0 Mode Pin Functionality

M[1:0] determine the functional mode of the device and select both the default User Defined Ratio and the set of modal parameters. The modal parameters are *RModSel[1:0]*, *AuxOutSrc[1:0]*, *LockClk[1:0]*, and *FracNSrc*. By modifying one or more of the modal parameters between the 4 sets, different functional configurations can be achieved. However, global parameters are fixed and the same value will be applied to each functional configuration. Figure 17 on page 22 provides a summary of all parameters used by the device.

5.7.2 M2 Mode Pin Functionality

M2 usage is mapped to one of the optional special functions via the *M2Config[2:0]* global parameter. Depending on what M2 is mapped to, it will either act as an output enable/disable pin or override certain modal parameters. Figure 16 summarizes the available options and the following sections will describe each option in more detail.

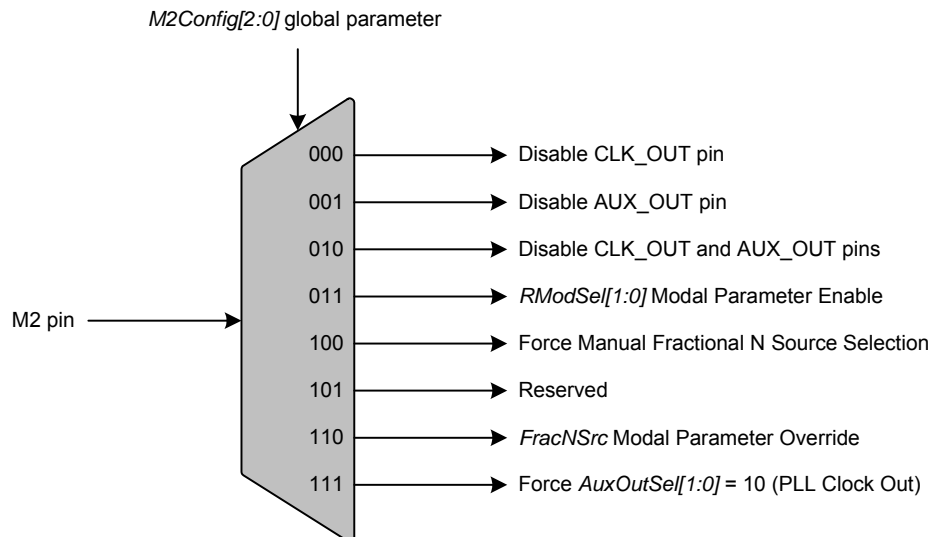

Figure 16. M2 Mapping Options

5.7.2.1 M2 Configured as Output Disable

If *M2Config[2:0]* is set to either '000', '001', or '010', M2 becomes an output disable pin for one or both output pins. If M2 is driven 'low', the corresponding output(s) will be enabled, if M2 is driven 'high', the corresponding output(s) will be disabled.

5.7.2.2 M2 Configured as R-Mod Enable

If *M2Config[2:0]* is set to '011', M2 becomes the R-Mod enable pin. It should be noted that M2 is the only way to enable R-Mod. Even though the *RModSel[1:0]* modal parameter can be set arbitrarily for each configuration set, it will not take effect unless enabled via M2. If M2 is driven 'low', R-Mod will be disabled, if M2 is driven 'high' R-Mod will be enabled.

5.7.2.3 **M2 Configured as Auto Fractional-N Source Selection Disable**

If *M2Config[2:0]* is set to '100', M2 becomes a disable pin for the auto fractional-N source selection functionality. If auto fractional-N source selection is enabled (see [section 5.4.5 on page 15](#)), driving M2 'high' will disable the auto fractional-N source selection and revert control over the fractional-N source to the *FracNSrc* modal parameter, regardless of the *LockClk[1:0]* modal parameter and the presence of a clock on CLK_IN. If auto fractional-N source selection is not enabled, toggling M2 will have no effect in this case.

5.7.2.4 **M2 Configured as Fractional-N Source Select**

If *M2Config[2:0]* is set to '110', M2 becomes the Fractional-N Source Select pin and will override the *FracNSrc* modal parameter. It should be noted that overriding *FracNSrc* has no effect when auto clock switching is enabled (see [section 5.4.5 on page 15](#)). If M2 is driven 'low', the fractional-N value will be the Static Ratio sourced directly from R_{EFF} for Frequency Synthesizer Mode. If M2 is driven 'high' the fractional-N value will be the Dynamic Ratio sourced from the Digital PLL for Hybrid PLL Mode.

5.7.2.5 **M2 Configured as AuxOutSrc Override**

If *M2Config[2:0]* is set to '111', M2 when driven 'high' will override the *AuxOutSrc[1:0]* modal parameter and force the AUX_OUT source to PLL Clock Output. When M2 is driven 'low', AUX_OUT will function according to *AuxOutSrc[1:0]*.

5.8 Clock Output Stability Considerations

5.8.1 **Output Switching**

The CS2000-OTP is designed such that re-configuration of the clock routing functions do not result in a partial clock period on any of the active outputs (CLK_OUT and/or AUX_OUT). In particular, enabling or disabling an output, changing the auxiliary output source between REF_CLK and CLK_OUT, changing between Frequency Synthesizer and Hybrid PLL Mode, and the automatic disabling of the output(s) during unlock will not cause a runt or partial clock period.

The following exceptions/limitations exist:

- Enabling/disabling AUX_OUT when *AuxOutSrc[1:0]* = 11 (unlock indicator).
- Switching *AuxOutSrc[1:0]* to or from 01 (CLK_IN) and to or from 11 (unlock indicator) (Transitions between *AuxOutSrc[1:0]* = [00,10] will not produce a glitch).

When any of these exceptions occur, a partial clock period on the output may result.

5.8.2 PLL Unlock Conditions

Certain changes to the clock inputs and mode pins can cause the PLL to lose lock which will affect the presence of a clock signal on CLK_OUT. The following outlines which conditions cause the PLL to go unlocked:

- Any change in the state of the M1 and M0 pins will cause the PLL to temporarily lose lock as the new setting takes affect.
- Changes made to the state of the M2 when the *M2Config[2:0]* global parameter is set to 011, 100, 101, or 110 can cause the PLL to temporarily lose lock as the new setting takes affect.
- Any discontinuities on the Timing Reference Clock, REF_CLK.
- Discontinuities on the Frequency Reference Clock, CLK_IN.
- Gradual changes in CLK_IN frequency greater than $\pm 30\%$ from the starting frequency.
- Step changes in CLK_IN frequency.

5.9 Required Power Up Sequencing for Programmed Devices

- Apply power. All input pins, except XTI/REF_CLK, should be held in a static logic hi or lo state until the DC Power Supply specification in the “[Recommended Operating Conditions](#)” table on [page 6](#) are met.
- Apply input clock(s) if required.
- For CDK programmed devices, toggle the state of the M0, M1, or both pins at least 3 times to initialize the device. This must be done after the power supply is stable and before normal operation is expected.
Note: This operation is not required for factory programmed devices.
- After the specified PLL lock time on [page 7](#) has passed, the device will output the desired clock as configured by the M0-M2 pins.

6. PARAMETER DESCRIPTIONS

As mentioned in [Section 5.1 on page 11](#), there are two different kinds of parameter configuration sets, Modal and Global. These configuration sets, shown in [Figure 17](#), can be programmed in the field using the CDK2000 or pre-programmed at the factory. Please see [“Programming Information” on page 27](#) for more details.

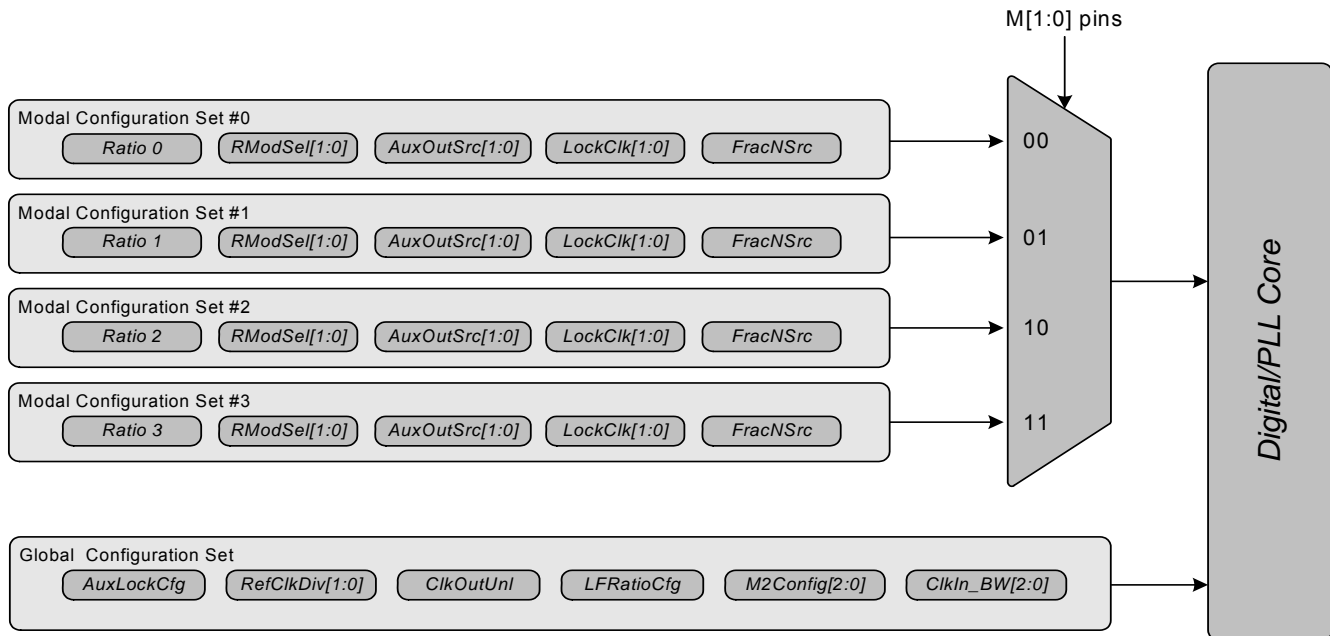

Figure 17. Parameter Configuration Sets

6.1 Modal Configuration Sets

There are four instances of each of these configuration parameters. Selection between the four stored sets is made using the M[1:0] pins.

6.1.1 R-Mod Selection (RModSel[1:0])

Selects the R-Mod value, which is used as a factor in determining the PLL's Fractional N.

RModSel[1:0]	R-Mod Selection
00	Right-shift R-value by 1 ($\div 2$).
01	Right-shift R-value by 2 ($\div 4$).
10	Right-shift R-value by 3 ($\div 8$).
11	Right-shift R-value by 4 ($\div 16$).
Application:	“Ratio Modifier (R-Mod)” on page 15

Note: This parameter does not take affect unless M2 pin is high and the *M2Config[2:0]* global parameter is set to '011'.

6.1.2 Auxiliary Output Source Selection (*AuxOutSrc[1:0]*)

Selects the source of the AUX_OUT signal.

AuxOutSrc[1:0]	Auxiliary Output Source
00	RefClk.
01	CLK_IN.
10	CLK_OUT.
11	PLL Lock Status Indicator.
Application:	"Auxiliary Output" on page 18

Note: When set to 11, the *AuxLockCfg* global parameter sets the polarity and driver type ("[AUX PLL Lock Output Configuration \(AuxLockCfg\)](#)" on page 24).

6.1.3 Lock Clock Ratio (*LockClk[1:0]*)

Selects one of the four stored User Defined Ratios for use in the dynamic ratio based Hybrid PLL Mode.

LockClk[1:0]	CLK_IN Ratio Selection
00	Ratio 0.
01	Ratio 1.
10	Ratio 2.
11	Ratio 3.
Application:	Section 5.4.2 on page 14

Note: The User Defined Ratio for the static ratio based Frequency Synthesizer mode is the ratio that corresponds with the currently chosen configuration set as shown in [Figure 17 on page 22](#).

6.1.4 Fractional-N Source for Frequency Synthesizer (*FracNSrc*)

Selects static or dynamic ratio mode when auto clock switching is disabled.

FracNSrc	Fractional-N Source Selection
0	Static Ratio directly from R _{EFF} for Frequency Synthesizer Mode
1	Dynamic Ratio from Digital PLL for Hybrid PLL Mode
Application:	"Fractional-N Source Selection" on page 15

6.2 Ratio 0 - 3

The four 32-bit User Defined Ratios are stored in the CS2000's one time programmable memory. See "[Output to Input Frequency Ratio Configuration](#)" on page 14 and "[Calculating the User Defined Ratio](#)" on page 26 for more details.

6.3 Global Configuration Parameters

6.3.1 AUX PLL Lock Output Configuration (AuxLockCfg)

When the AUX_OUT pin is configured as a lock indicator (*AuxOutSrc[1:0]* modal parameter = '11'), this global parameter configures the AUX_OUT driver to either push-pull or open drain. It also determines the polarity of the lock signal. If AUX_OUT is configured as a clock output, the state of this parameter is disregarded.

AuxLockCfg	AUX_OUT Driver Configuration
0	Push-Pull, Active High (output 'high' for unlocked condition, 'low' for locked condition).
1	Open Drain, Active Low (output 'low' for unlocked condition, high-Z for locked condition).
Application:	"Auxiliary Output" on page 18

Note: AUX_OUT is an **unlock** indicator, signalling an error condition when the PLL is unlocked. Therefore, the pin polarity is defined relative to the **unlock** condition.

6.3.2 Reference Clock Input Divider (RefClkDiv[1:0])

Selects the input divider for the timing reference clock.

RefClkDiv[1:0]	Reference Clock Input Divider	REF_CLK Frequency Range
00	+ 4.	32 MHz to 56 MHz (50 MHz with XTI)
01	+ 2.	16 MHz to 28 MHz
10	+ 1.	8 MHz to 14 MHz
11	Reserved.	
Application:	"Internal Timing Reference Clock Divider" on page 11	

6.3.3 Enable PLL Clock Output on Unlock (ClkOutUnl)

Defines the state of the PLL output during the PLL unlock condition.

ClkOutUnl	Clock Output Enable Status
0	Clock outputs are driven 'low' when PLL is unlocked.
1	Clock outputs are always enabled (results in unpredictable output when PLL is unlocked).
Application:	"PLL Clock Output" on page 18

6.3.4 Low-Frequency Ratio Configuration (LFRatioCfg)

Determines how to interpret the currently indexed 32-bit User Defined Ratio when the dynamic ratio based Hybrid PLL Mode is selected (either manually or automatically, see [section 5.4.5 on page 15](#)).

LFRatioCfg	Ratio Bit Encoding Interpretation when Input Clock Source is CLK_IN
0	20.12 - High Multiplier.
1	12.20 - High Accuracy.
Application:	"User Defined Ratio (RUD), Frequency Synthesizer Mode" on page 14

Note: When the static ratio based Frequency Synthesizer Mode is selected (either manually or automatically), the currently indexed User Defined Ratio will always be interpreted as a 12.20 fixed point value, regardless of how this parameter is set.



6.3.5 M2 Pin Configuration (M2Config[2:0])

Controls which special function is mapped to the M2 pin.

M2Config[2:0]	M2 pin function
000	Disable CLK_OUT pin.
001	Disable AUX_OUT pin.
010	Disable CLK_OUT and AUX_OUT.
011	<i>RModSel[1:0]</i> Modal Parameter Enable.
100	Force Manual Fractional N Source Selection.
101	Reserved.
110	<i>FracNSrc</i> Modal Parameter Override
111	Force <i>AuxOutSrc[1:0]</i> = 10 (PLL Clock Out).
Application:	"M2 Mode Pin Functionality" on page 19

6.3.6 Clock Input Bandwidth (ClkIn_BW[2:0])

Sets the minimum loop bandwidth when locked to CLK_IN.

ClkIn_BW[2:0]	Minimum Loop Bandwidth
000	1 Hz
001	2 Hz
010	4 Hz
011	8 Hz
100	16 Hz
101	32 Hz
110	64 Hz
111	128 Hz
Application:	"Adjusting the Minimum Loop Bandwidth for CLK_IN" on page 13

7. CALCULATING THE USER DEFINED RATIO

Note: The software for use with the evaluation kit has built in tools to aid in calculating and converting the User Defined Ratio. This section is for those who would like to know more about how the User Defined Ratio is calculated and stored.

Most calculators do not interpret the fixed point binary representation which the CS2000-OTP uses to define the output to input clock ratio (see [Section 5.4.1 on page 14](#)); However, with a simple conversion we can use these tools to generate a binary or hex value for $Ratio_{0-3}$ to be stored in one time programmable memory. Please see “[Programming Information](#)” on [page 27](#) for more details on programming.

7.1 High Resolution 12.20 Format

To calculate the User Defined Ratio (R_{UD}) to store in the register(s), divide the desired output clock frequency by the given input clock (CLK_IN or RefClk). Then multiply the desired ratio by the scaling factor of 2^{20} to get the scaled decimal representation; then use the decimal to binary/hex conversion function on a calculator and write to the register. A few examples have been provided in [Table 3](#).

Desired Output to Input Clock Ratio (output clock/input clock)	Scaled Decimal Representation = (output clock/input clock) • 2^{20}	Hex Representation of Binary R_{UD}
12.288 MHz/10 MHz=1.2288	1288490	00 13 A9 2A
11.2896 MHz/44.1 kHz=256	268435456	10 00 00 00

Table 3. Example 12.20 R-Values

7.2 High Multiplication 20.12 Format

To calculate the User Defined Ratio (R_{UD}) to store in the register(s), divide the desired output clock frequency by the given input clock (CLK_IN). Then multiply the desired ratio by the scaling factor of 2^{12} to get the scaled decimal representation; then use the decimal to binary/hex conversion function on a calculator and write to the register. A few examples have been provided in [Table 4](#).

Desired Output to Input Clock Ratio (output clock/input clock)	Scaled Decimal Representation = (output clock/input clock) • 2^{12}	Hex Representation of Binary R_{UD}
12.288 MHz/60 Hz=204,800	838860800	32 00 00 00
11.2896 MHz/59.97 Hz =188254.127...	771088904	2D F5 E2 08

Table 4. Example 20.12 R-Values



8. PROGRAMMING INFORMATION

Field programming of the CS2000-OTP is achieved using the hardware and software tools included with the CDK2000. The software tools can be downloaded from www.cirrus.com for evaluation prior to ordering a CDK. The CDK2000 is designed with built-in features to ease the process of programming small quantities of devices for prototype and small production builds. In addition to its field programming capabilities, the CDK2000 can also be used for the complete evaluation of programmed CS2000-OTP devices.

The CS2000-OTP can also be factory programmed for large quantity orders. When ordering factory programmed devices, the CDK should first be used to program and evaluate the desired configuration. When evaluation is complete, the CS2000 Configuration Wizard is used to generate a file containing all device configuration information; this file is conveyed to Cirrus Logic as a complete specification for the factory programming configuration. Please contact your local Cirrus Logic sales representative for more information regarding factory programmed parts.

See the CDK2000 datasheet, available at www.cirrus.com, for detailed information on the use of the CDK2000 programming and evaluation tools.

Below is a form which represents the information required for programming a device (noted in gray). The “[Parameter Descriptions](#)” section beginning on page 22 describes the functions of each parameter. This form may be used either for personal notation for device configuration or it can be filled out and given to a Cirrus representative in conjunction with the programming file from the CDK2000 as an additional check. The User Defined Ratio may be filled out in decimal or it may be entered as hex as outlined in “[Calculating the User Defined Ratio](#)” on page 26. For all other parameters mark a ‘0’ or ‘1’ below the parameter name.

OTP Modal and Global Configuration Parameters Form								
Modal Configuration Set #0								
Ratio 0 (dec)								
Ratio 0 (hex)	_____ : _____ : _____ : _____							
	RModSel1	RModSel0	AuxOutSrc1	AuxOutSrc0	LockClk1	LockClk0	FracNSrc	
Modal Configuration Set #1								
Ratio 1 (dec)								
Ratio 1 (hex)	_____ : _____ : _____ : _____							
	RModSel1	RModSel0	AuxOutSrc1	AuxOutSrc0	LockClk1	LockClk0	FracNSrc	
Modal Configuration Set #2								
Ratio 2 (dec)								
Ratio 2 (hex)	_____ : _____ : _____ : _____							
	RModSel1	RModSel0	AuxOutSrc1	AuxOutSrc0	LockClk1	LockClk0	FracNSrc	
Modal Configuration Set #3								
Ratio 3 (dec)								
Ratio 3 (hex)	_____ : _____ : _____ : _____							
	RModSel1	RModSel0	AuxOutSrc1	AuxOutSrc0	LockClk1	LockClk0	FracNSrc	
Global Configuration Set								
AuxLockCfg	RefClkDiv1	RefClkDiv0	ClkOutUnl	LFRatioCfg	M2Cfg2	M2Cfg1	M2Cfg0	
ClkIn_BW2	ClkIn_BW1	ClkIn_BW0						

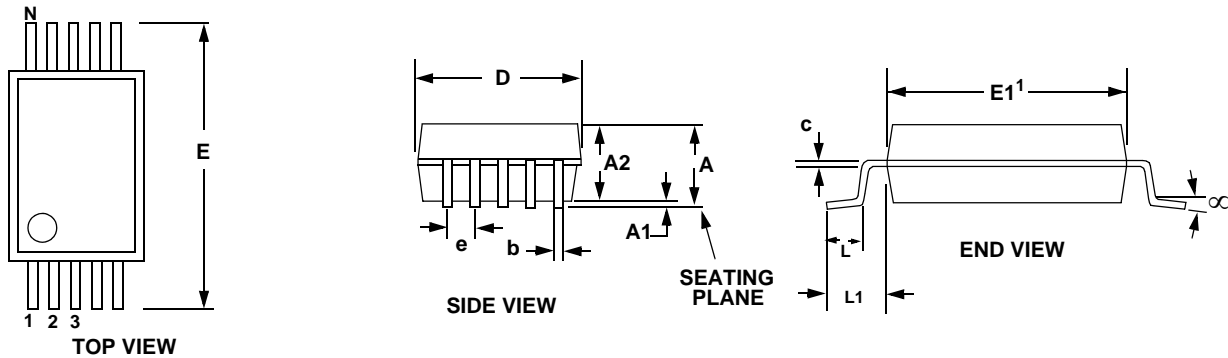
9. PACKAGE DIMENSIONS**10L MSOP (3 mm BODY) PACKAGE DRAWING (Note 1)**

DIM	INCHES			MILLIMETERS			NOTE
	MIN	NOM	MAX	MIN	NOM	MAX	
A	--	--	0.0433	--	--	1.10	
A1	0	--	0.0059	0	--	0.15	
A2	0.0295	--	0.0374	0.75	--	0.95	
b	0.0059	--	0.0118	0.15	--	0.30	4, 5
c	0.0031	--	0.0091	0.08	--	0.23	
D	--	0.1181 BSC	--	--	3.00 BSC	--	2
E	--	0.1929 BSC	--	--	4.90 BSC	--	
E1	--	0.1181 BSC	--	--	3.00 BSC	--	3
e	--	0.0197 BSC	--	--	0.50 BSC	--	
L	0.0157	0.0236	0.0315	0.40	0.60	0.80	
L1	--	0.0374 REF	--	--	0.95 REF	--	

Notes: 1. Reference document: JEDEC MO-187

2. D does not include mold flash or protrusions which is 0.15 mm max. per side.
3. E1 does not include inter-lead flash or protrusions which is 0.15 mm max per side.
4. Dimension b does not include a total allowable dambar protrusion of 0.08 mm max.
5. Exceptions to JEDEC dimension.

THERMAL CHARACTERISTICS

Parameter	Symbol	Min	Typ	Max	Units
Junction to Ambient Thermal Impedance	JEDEC 2-Layer θ_{JA}	-	170	-	°C/W
	JEDEC 4-Layer θ_{JA}	-	100	-	°C/W
Junction to Case Thermal Impedance	θ_{JC}	-	30.2	-	°C/W
Junction to Top Thermal Characteristic (Center of Package)	Ψ_{JT}	-	6	-	°C/W



10. ORDERING INFORMATION

The CS2000-OTP is ordered as an un-programmed device. The CS2000-OTP can also be factory programmed for large quantity orders. Please see [“Programming Information” on page 27](#) for more details.

Product	Description	Package	Pb-Free	Grade	Temp Range	Container	Order#
CS2000-OTP	Clocking Device	10L-MSOP	Yes	Commercial	-10° to +70°C	Rail	CS2000P-CZZ
CS2000-OTP	Clocking Device	10L-MSOP	Yes		-10° to +70°C	Tape and Reel	CS2000P-CZZR
CS2000-OTP	Clocking Device	10L-MSOP	Yes	Automotive-D	-40° to +85°C	Rail	CS2000P-DZZ
CS2000-OTP	Clocking Device	10L-MSOP	Yes		-40° to +85°C	Tape and Reel	CS2000P-DZZR
CS2000-OTP	Clocking Device	10L-MSOP	Yes	Automotive-E	-40° to +105°C	Rail	CS2000P-EZZ
CS2000-OTP	Clocking Device	10L-MSOP	Yes		-40° to +105°C	Tape and Reel	CS2000P-EZZR
CDK2000	Evaluation Platform	-	Yes	-	-	-	CDK2000-CLK

11. REVISION HISTORY

Release	Changes
F1 AUG '09	Updated Period Jitter specification in “AC Electrical Characteristics” on page 7 . Updated Crystal and Ref Clock Frequency specifications in “AC Electrical Characteristics” on page 7 . Added “PLL Performance Plots” section on page 8 . Updated “Internal Timing Reference Clock Divider” on page 11 and added Figure 9 on page 12 . Removed CLK_IN Skipping Mode. Removed Auto R-Mod. Added Mode pin toggle requirement to startup for CDK programmed devices to “Required Power Up Sequencing for Programmed Devices” on page 21 .
F2 MAY '10	Updated to add Automotive Grade temperature ranges and ordering options.
F3 OCT '15	Updated to add Automotive-E grade temperature ranges and ordering options. Added Note 7 regarding ratio-limited f_{CLK_OUT} in “AC Electrical Characteristics” on page 7 . Updated frequency ranges in Figure 2 on page 8 and Figure 3 on page 8 . Added unlock conditions to “Auxiliary Output” on page 18 . Added two thermal characteristics in “Thermal Characteristics” on page 28 . Updated legal verbiage.

Important: Please check www.Cirrus.com to confirm that you are using the latest revision of this document and to determine whether there are errata associated with this device.

Contacting Cirrus Logic Support

For all product questions and inquiries, contact a Cirrus Logic Sales Representative.

To find one nearest you, go to www.cirrus.com

IMPORTANT NOTICE

The products and services of Cirrus Logic International (UK) Limited; Cirrus Logic, Inc.; and other companies in the Cirrus Logic group (collectively either "Cirrus Logic" or "Cirrus") are sold subject to Cirrus's terms and conditions of sale supplied at the time of order acknowledgment, including those pertaining to warranty, indemnification, and limitation of liability. Software is provided pursuant to applicable license terms. Cirrus reserves the right to make changes to its products and specifications or to discontinue any product or service without notice. Customers should therefore obtain the latest version of relevant information from Cirrus to verify that the information is current and complete. Testing and other quality control techniques are utilized to the extent Cirrus deems necessary. Specific testing of all parameters of each device is not necessarily performed. In order to minimize risks associated with customer applications, the customer must use adequate design and operating safeguards to minimize inherent or procedural hazards. Cirrus is not liable for applications assistance or customer product design. The customer is solely responsible for its selection and use of Cirrus products. Use of Cirrus products may entail a choice between many different modes of operation, some or all of which may require action by the user, and some or all of which may be optional. Nothing in these materials should be interpreted as instructions or suggestions to choose one mode over another. Likewise, description of a single mode should not be interpreted as a suggestion that other modes should not be used or that they would not be suitable for operation. Features and operations described herein are for illustrative purposes only.

CERTAIN APPLICATIONS USING SEMICONDUCTOR PRODUCTS MAY INVOLVE POTENTIAL RISKS OF DEATH, PERSONAL INJURY, OR SEVERE PROPERTY OR ENVIRONMENTAL DAMAGE ("CRITICAL APPLICATIONS"). CIRRUS PRODUCTS ARE NOT DESIGNED, AUTHORIZED OR WARRANTED FOR USE IN PRODUCTS SURGICALLY IMPLANTED INTO THE BODY, AUTOMOTIVE SAFETY OR SECURITY DEVICES, NUCLEAR SYSTEMS, LIFE SUPPORT PRODUCTS OR OTHER CRITICAL APPLICATIONS. INCLUSION OF CIRRUS PRODUCTS IN SUCH APPLICATIONS IS UNDERSTOOD TO BE FULLY AT THE CUSTOMER'S RISK AND CIRRUS DISCLAIMS AND MAKES NO WARRANTY, EXPRESS, STATUTORY OR IMPLIED, INCLUDING THE IMPLIED WARRANTIES OF MERCHANTABILITY AND FITNESS FOR PARTICULAR PURPOSE, WITH REGARD TO ANY CIRRUS PRODUCT THAT IS USED IN SUCH A MANNER. IF THE CUSTOMER OR CUSTOMER'S CUSTOMER USES OR PERMITS THE USE OF CIRRUS PRODUCTS IN CRITICAL APPLICATIONS, CUSTOMER AGREES, BY SUCH USE, TO FULLY INDEMNIFY CIRRUS, ITS OFFICERS, DIRECTORS, EMPLOYEES, DISTRIBUTORS AND OTHER AGENTS FROM ANY AND ALL LIABILITY, INCLUDING ATTORNEYS' FEES AND COSTS, THAT MAY RESULT FROM OR ARISE IN CONNECTION WITH THESE USES.

This document is the property of Cirrus and by furnishing this information, Cirrus grants no license, express or implied, under any patents, mask work rights, copyrights, trademarks, trade secrets or other intellectual property rights. Any provision or publication of any third party's products or services does not constitute Cirrus's approval, license, warranty or endorsement thereof. Cirrus gives consent for copies to be made of the information contained herein only for use within your organization with respect to Cirrus integrated circuits or other products of Cirrus, and only if the reproduction is without alteration and is accompanied by all associated copyright, proprietary and other notices and conditions (including this notice). This consent does not extend to other copying such as copying for general distribution, advertising or promotional purposes, or for creating any work for resale. This document and its information is provided "AS IS" without warranty of any kind (express or implied). All statutory warranties and conditions are excluded to the fullest extent possible. No responsibility is assumed by Cirrus for the use of information herein, including use of this information as the basis for manufacture or sale of any items, or for infringement of patents or other rights of third parties. Cirrus Logic, Cirrus, the Cirrus Logic logo design, and SoundClear are among the trademarks of Cirrus. Other brand and product names may be trademarks or service marks of their respective owners.

Copyright © 2009–2015 Cirrus Logic, Inc. All rights reserved.

SPI is a trademark of Motorola.

OUR CERTIFICATE

DiGi provide top-quality products and perfect service for customer worldwide through standardization, technological innovation and continuous improvement. DiGi through third-party certification, we stricly control the quality of products and services. Welcome your RFQ to

Email: Info@DiGi-Electronics.com



Tel: +00 852-30501935

RFQ Email: Info@DiGi-Electronics.com

DiGi is a global authorized distributor of electronic components.